

**TECHNICAL MANUAL
MAINTENANCE INSTRUCTIONS
DIRECT SUPPORT AND GENERAL SUPPORT**

**M977 SERIES 8 x 8 HEAVY
EXPANDED MOBILITY
TACTICAL TRUCKS (HEMTT)**

TABLE OF CONTENTS
PAGE ii

INTRODUCTION
PAGE 1-1

MAINTENANCE INSTRUCTIONS
PAGE 2-1

TROUBLESHOOTING
PAGE 2-2

MAINTENANCE PROCEDURES
PAGE 2-145

ENGINE MAINTENANCE
PAGE 3-1

FUEL SYSTEM MAINTENANCE
PAGE 4-1

COOLING SYSTEM MAINTENANCE
PAGE 5-1

ELECTRICAL SYSTEM MAINTENANCE
PAGE 6-1

TRANSMISSION MAINTENANCE
PAGE 7-1

TRANSFER CASE MAINTENANCE
PAGE 8-1

AXLES NO. 1 AND NO. 2 MAINTENANCE
PAGE 9-1

ALPHABETICAL INDEX
PAGE INDEX 1

MODEL	NSN
TRUCK, CARGO, WITH WINCH, M977	2320-01-097-0260
TRUCK, CARGO, WITH WINCH, M977A2	2320-01-493-3774
TRUCK, CARGO, WITH WINCH, M977A2R1	2320-01-493-3782
TRUCK, CARGO, WITHOUT WINCH, M977	2320-01-099-6426
TRUCK, CARGO, WITHOUT WINCH, M977A2	2320-01-493-3779
TRUCK, CARGO, WITHOUT WINCH, M977A2R1	2320-01-493-3785
TRUCK, TANK, FUEL, WITH WINCH, M978	2320-01-097-0249
TRUCK, TANK, FUEL, WITH WINCH, M978A2	2320-01-492-8216
TRUCK, TANK, FUEL, WITH WINCH, M978A2R1	2320-01-492-8226
TRUCK, TANK, FUEL, WITHOUT WINCH, M978	2320-01-100-7672
TRUCK, TANK, FUEL, WITHOUT WINCH, M978A2	2320-01-492-8215
TRUCK, TANK, FUEL, WITHOUT WINCH, M978A2R1	2320-01-492-8225
TRUCK, TRACTOR, WITH WINCH, WITHOUT CRANE, M983	2320-01-097-0247
TRUCK, TRACTOR, WITH WINCH, WITHOUT CRANE, M983A2	2320-01-492-8223
TRUCK, TRACTOR, WITH WINCH, WITHOUT CRANE, M983A2R1	2320-01-492-8231
TRUCK, TRACTOR, WITH WINCH, WITH CRANE, M983	2320-01-099-6421
TRUCK, WRECKER-RECOVERY, M984	2320-01-097-0248
TRUCK, WRECKER-RECOVERY, M984A1	2320-01-195-7641
TRUCK, WRECKER-RECOVERY, M984A2	2320-01-492-8224
TRUCK, WRECKER-RECOVERY, M984A2R1	2320-01-492-8233
TRUCK, CARGO, WITH WINCH, M985	2320-01-097-0261
TRUCK, CARGO, WITH WINCH, M985A2	2320-01-492-8214
TRUCK, CARGO, WITH WINCH, M985A2R1	2320-01-493-3787
TRUCK, CARGO, WITHOUT WINCH, M985	2320-01-100-7673
TRUCK, CARGO, WITHOUT WINCH, M985A2	2320-01-492-8201
TRUCK, CARGO, WITHOUT WINCH, M985A2R1	2320-01-493-3789
TRUCK, CARGO, WITH WINCH, M985E1	2320-01-194-7032
TRUCK, CARGO, WITH WINCH, M985E1A2	2320-01-493-3790
TRUCK, CARGO, WITH WINCH, M985E1A2R1	2320-01-493-3792

Approved for public release; distribution is unlimited.

WARNING

CARBON MONOXIDE (EXHAUST GAS) CAN CAUSE DEATH.

Carbon monoxide is without color or smell, but can cause death. Breathing air with carbon monoxide produces symptoms of headache, dizziness, loss of muscular control, a sleepy feeling, and coma. Brain damage or death can result from heavy exposure. Carbon monoxide occurs in the exhaust fumes of fuel-burning heaters and internal combustion engines. Carbon monoxide can become dangerously concentrated under conditions of no ventilation. Precautions must be followed to ensure crew safety when the arctic engine heater or engine of any vehicle is operated for any purpose.

1. DO NOT operate arctic engine heater or engine of vehicle in a closed place without proper ventilation.
2. DO NOT drive any vehicle with inspection plates, cover plates, or engine compartment covers removed unless necessary for maintenance purposes.
3. BE ALERT at all times during vehicle operation for exhaust odors and exposure symptoms. If either are present, IMMEDIATELY VENTILATE personnel compartments. If symptoms persist, remove affected crew to fresh air and keep warm. DO NOT PERMIT PHYSICAL EXERCISE. If necessary, give artificial respiration and get immediate medical attention. For artificial respiration, refer to FM 21-11.
4. BE AWARE that the gas particulate filter unit or the field protection mask for nuclear-biological-chemical protection WILL NOT offer safety from carbon monoxide poisoning.

THE BEST DEFENSE AGAINST CARBON MONOXIDE POISONING IS GOOD VENTILATION.

WARNING

Adhesives, solvents, and sealing compounds can burn easily, can give off harmful vapors, and are harmful to skin and clothing. To avoid injury or death, keep away from open fire and use in well-ventilated area. If adhesive, solvent, or sealing compound gets on skin or clothing, wash immediately with soap and water.

WARNING

Never use the parking brake for normal braking or wheels will lock up causing severe skid. Skidding vehicle could result in serious injury or death.

WARNING

Fuel is very flammable and can explode easily. To avoid serious injury or death, keep fuel away from open fire and keep fire extinguisher within easy reach when working with fuel. Do not work on fuel system when engine is hot. Fuel can be ignited by hot engine. When working with fuel, post signs that read NO SMOKING WITHIN 50 FEET of vehicle.

WARNING

Remove rings, bracelets, wristwatches, neck chains, and any other jewelry before working around vehicle. Jewelry can catch on equipment and cause injury, or may short across an electrical circuit and cause severe burns or electrical shock.

WARNING

The radiator is very hot and pressurized during vehicle operation. Let radiator cool before removing cap. Failure to do so can result in serious burns.

WARNING

The exhaust pipe and muffler can become very hot during vehicle operation. Be careful not to touch these parts with bare hands, or allow body to come in contact with pipe or muffler. Exhaust system parts can become hot enough to cause serious burns.

WARNING

Do not use trailer brakes as parking brake. Trailer brakes may not hold a loaded vehicle and trailer on a grade. A runaway vehicle may cause severe personal injury or death.

WARNING

Always use seatbelts when operating vehicle. Failure to use seatbelt can result in serious injury in case of accident.

WARNING

Avoid quick, jerking, winch operation. Keep other personnel well away from vehicles involved in winching operations. A snapped cable or shifting load can cause serious injury or death.

WARNING

Always wear heavy gloves when handling winch cables. Never let cable run through hands; frayed cables can cut. Never operate winch with less than five wraps of cable on winch drum.

WARNING

If operating crane under powerlines, do not allow vehicle to contact high-voltage connections. Death on contact can result. If possible, keep one hand away from equipment to reduce the hazard of current flowing through vital organs of the body.

WARNING

When working inside the vehicle with power off, be sure to ground every capacitor likely to hold a dangerous voltage potential.

WARNING

Never work on electronic equipment unless there is another person nearby who is familiar with the operation and hazards of the equipment.

WARNING

Be careful when working on or with electrical equipment. Do not be misled by the term "low voltage". Voltages as low as 50 volts may cause death. For artificial respiration, refer to FM 21-11.

WARNING

Be careful not to short out battery terminals. Do not smoke or use open flame near batteries. Batteries may explode from a spark. Battery acid is harmful to skin and eyes.

WARNING

Brake shoes may be coated with dust. Breathing this dust may be harmful to your health. Do not use compressed air to clean brake shoes. Wear a filter mask approved for use against brake dust. Failure to comply may result in injury or death to personnel.

WARNING

Starting fluid is toxic and flammable. Do not store in cab and do not breathe fumes. Do not puncture or burn containers. Dispose of container following manufacturer's recommendations on the container.

WARNING

Compressed air used for cleaning purposes will not exceed 30 psi (207 kPa). Use only with effective chip guarding and personal protective equipment, goggles, shield, and gloves.

WARNING

After Nuclear, Biological, or Chemical (NBC) exposure of vehicle, all air filters shall be handled with extreme caution. Unprotected personnel can experience injury or death if residual toxic agents or radioactive material are present. If vehicle is exposed to chemical or biological agents, servicing personnel shall wear protective mask, hood, protective overgarments, and chemical protective gloves and boots in accordance with TM 10-277. All contaminated air filters shall be placed in double-lined plastic bags and moved swiftly to a segregation area away from the worksite. The same procedure applies for radioactive dust contamination. The Company NBC team should measure the radiation prior to filter removal to determine the extent of safety procedures required per the NBC Annex to the unit Standard Operating Procedures (SOP). The segregation area in which the contaminated air filters are temporarily stored shall be marked with appropriate NBC placards. Final disposal of contaminated air filters shall be in accordance with local SOP. Decontamination operation shall be in accordance with FM 3-5 and local SOP.

WARNING

DO NOT grind or sand painted equipment without high-efficiency air purifying respirators in use.

WARNING

Adhesives, solvents, and sealing compounds can burn easily, can give off harmful vapors, and are harmful to skin and clothing. To avoid injury or death, keep away from open fire and use in well-ventilated area. If adhesive, solvent, or sealing compound gets on skin or clothing, wash immediately with soap and water.

WARNING

Use extreme care when removing or installing spring retainers. Spring retainers are under tension and can act as projectiles when released suddenly. Ensure proper eye protection is worn to prevent injury to personnel.

WARNING

Use extreme care when removing or installing springs. Springs are under tension and can act as projectiles when released. Ensure proper eye protection is worn to prevent injury to personnel.

WARNING

CARC paint contains isocyanate (HDI) which is highly irritating to skin and respiratory system. High concentrations of HDI can produce symptoms of itching and reddening of skin, a burning sensation in throat and nose, and watering of the eyes. In extreme concentrations, HDI can cause cough, shortness of breath, pain during respiration, increased sputum production, and chest tightness. The following precautions must be taken whenever using CARC paint:

- ALWAYS use air-line respirators when using CARC paint unless air sampling shows exposure to be below standards. Use chemical cartridge respirator if air sampling is below standards.
- DO NOT let skin or eyes come in contact with CARC paint. Always wear protective equipment (gloves, ventilation mask, safety goggles, etc.).
- DO NOT use CARC paint without adequate ventilation.
- NEVER weld or cut CARC coated materials.
- DO NOT grind or sand painted equipment without high-efficiency, air-purifying respirators in use.
- BE AWARE of CARC paint exposure symptoms: symptoms can occur a few days after initial exposure. Seek medical help immediately if symptoms are detected.

WARNING

- Eye protection is required during all grinding operations. Failure to comply may result in serious injury to personnel.
- Take all necessary precautions to confine grinding sparks so they cannot contact flammable or combustible materials or vapors. Failure to comply may result in serious injury or death to personnel.
- When grinding, avoid creating excess heat on CARC painted surfaces near grinding area. CARC paint can ignite if heated. Failure to comply may result in serious injury or death to personnel.

WARNING**CHEMICAL AGENT RESISTANT COATING (CARC)**

Unusable CARC mixtures are considered hazardous waste and will require disposal in accordance with Federal, state, Department of Defense, Department of the Army, and local installation hazardous waste regulations. Consult the installation environmental office for proper disposal guidance. Mixed CARC is extremely flammable. Use only in well-ventilated areas. Keep away from open flames, sparks, and other ignition sources.

CARC paint contains isocyanate (HDI), which is highly irritating to skin and respiratory system. High concentrations of HDI can produce symptoms of itching and reddening of skin, a burning sensation in throat and nose, and watering of the eyes. In extreme concentrations, HDI can cause cough, shortness of breath, pain during respiration, increased sputum production, and chest tightness. The following precautions must be taken whenever using CARC paint:

- ALWAYS use air-line respirators when using CARC paint unless air sampling shows exposure to be below standards. Use chemical cartridge respirator if air sampling is below standards.
- DO NOT use CARC paint without adequate ventilation.
- NEVER weld or cut CARC coated materials.
- DO NOT grind or sand painted equipment without high-efficiency, air-purifying respirators in use.
- BE AWARE of CARC paint exposure symptoms: symptoms can occur a few days after initial exposure. Seek medical help immediately if symptoms are detected.

CHANGE

NO. 7

HEADQUARTERS
DEPARTMENT OF THE ARMY
WASHINGTON, D.C. 20315 July, 2005

TECHNICAL MANUAL

MAINTENANCE INSTRUCTIONS

DIRECT SUPPORT AND GENERAL SUPPORT

M977 SERIES, 8 X 8 HEAVY EXPANDED MOBILITY
TACTICAL TRUCKS (HEMTT)

MODEL	NSN
TRUCK, CARGO, WITH WINCH, M977	2320-01-097-0260
TRUCK, CARGO, WITH WINCH, M977A2	2320-01-493-3774
TRUCK, CARGO, WITH WINCH, M977A2R1	2320-01-493-3782
TRUCK, CARGO, WITHOUT WINCH, M977	2320-01-099-6426
TRUCK, CARGO, WITHOUT WINCH, M977A2	2320-01-493-3779
TRUCK, CARGO, WITHOUT WINCH, M977A2R1	2320-01-493-3785
TRUCK, TANK, FUEL, WITH WINCH, M978	2320-01-097-0249
TRUCK, TANK, FUEL, WITH WINCH, M978A2	2320-01-492-8216
TRUCK, TANK, FUEL, WITH WINCH, M978A2R1	2320-01-492-8226
TRUCK, TANK, FUEL, WITHOUT WINCH, M978	2320-01-100-7672
TRUCK, TANK, FUEL, WITHOUT WINCH, M978A2	2320-01-492-8215
TRUCK, TANK, FUEL, WITHOUT WINCH, M978A2R1	2320-01-492-8225
TRUCK, TRACTOR, WITH WINCH, WITHOUT CRANE, M983	2320-01-097-0247
TRUCK, TRACTOR, WITH WINCH, WITHOUT CRANE, M983A2	2320-01-492-8223
TRUCK, TRACTOR, WITH WINCH, WITHOUT CRANE, M983A2R1	2320-01-492-8231
TRUCK, TRACTOR, WITH WINCH, WITH CRANE, M983	2320-01-099-6421
TRUCK, WRECKER-RECOVERY, M984	2320-01-097-0248
TRUCK, WRECKER-RECOVERY, M984A1	2320-01-195-7641
TRUCK, WRECKER-RECOVERY, M984A2	2320-01-492-8224
TRUCK, WRECKER-RECOVERY, M984A2R1	2320-01-492-8233
TRUCK, CARGO, WITH WINCH, M985	2320-01-097-0261
TRUCK, CARGO, WITH WINCH, M985A2	2320-01-492-8214
TRUCK, CARGO, WITH WINCH, M985A2R1	2320-01-493-3787
TRUCK, CARGO, WITHOUT WINCH, M985	2320-01-100-7673
TRUCK, CARGO, WITHOUT WINCH, M985A2	2320-01-492-8201
TRUCK, CARGO, WITHOUT WINCH, M985A2R1	2320-01-493-3789
TRUCK, CARGO, WITH WINCH, M985E1	2320-01-194-7032
TRUCK, CARGO, WITH WINCH, M985E1A2	2320-01-493-3790
TRUCK, CARGO, WITH WINCH, M985E1A2R1	2320-01-493-3792

Approved for public release; distribution is unlimited.

TM 9-2320-279-34-1, June 1987, is changed as follows:

1. Remove old pages and insert new pages as indicated below.
2. New or changed material is indicated by a vertical bar in the margin of the page.
3. Minor changes to illustrations are indicated by a miniature pointing hand.
4. Illustrations that are new or that have major revisions are indicated by a vertical bar adjacent to the illustration identification number.

Remove Pages	Insert Pages
A thru C/(D blank)	A thru C/(D blank)
c/(d blank)	c and d
1-1 and 1-2	1-1 and 1-2
6-73 and 6-74	6-73 and 6-74
6-83 and 6-84	6-83 and 6-84
none	6-84.1/(6-84.2 blank)
9-13 and 9-14	9-13 and 9-14
none	9-14.1/(9-14.2 blank)
9-15 and 9-16	9-15 and 9-16
9-89 and 9-90	9-89 and 9-90
Cover	Cover

File this change sheet in front of the publication for reference purposes.

By Order of the Secretary of the Army:

Official:

PETER J. SCHOOMAKER
General, United States Army
Chief of Staff

SANDRA R. RILEY
Administrative Assistant to the
Secretary of the Army
0422207

DISTRIBUTION: To be distributed in accordance with the Initial Distribution Number IDN: 380653, requirements for TM 9-2320-279-34-1.

CHANGE

NO. 6

HEADQUARTERS
DEPARTMENT OF THE ARMY
WASHINGTON, D.C., 15 December, 2003

TECHNICAL MANUAL

MAINTENANCE INSTRUCTIONS

DIRECT SUPPORT AND GENERAL SUPPORT

M977 SERIES, 8 X 8 HEAVY EXPANDED MOBILITY
TACTICAL TRUCKS (HEMTT)

MODEL	NSN
TRUCK, CARGO, WITH WINCH, M977	2320-01-097-0260
TRUCK, CARGO, WITH WINCH, M977A2	2320-01-493-3774
TRUCK, CARGO, WITH WINCH, M977A2R1	2320-01-493-3782
TRUCK, CARGO, WITHOUT WINCH, M977	2320-01-099-6426
TRUCK, CARGO, WITHOUT WINCH, M977A2	2320-01-493-3779
TRUCK, CARGO, WITHOUT WINCH, M977A2R1	2320-01-493-3785
TRUCK, TANK, FUEL, WITH WINCH, M978	2320-01-097-0249
TRUCK, TANK, FUEL, WITH WINCH, M978A2	2320-01-492-8216
TRUCK, TANK, FUEL, WITH WINCH, M978A2R1	2320-01-492-8226
TRUCK, TANK, FUEL, WITHOUT WINCH, M978	2320-01-100-7672
TRUCK, TANK, FUEL, WITHOUT WINCH, M978A2	2320-01-492-8215
TRUCK, TANK, FUEL, WITHOUT WINCH, M978A2R1	2320-01-492-8225
TRUCK, TRACTOR, WITH WINCH, WITHOUT CRANE, M983	2320-01-097-0247
TRUCK, TRACTOR, WITH WINCH, WITHOUT CRANE, M983A2	2320-01-492-8223
TRUCK, TRACTOR, WITH WINCH, WITHOUT CRANE, M983A2R1	2320-01-492-8231
TRUCK, TRACTOR, WITH WINCH, WITH CRANE, M983	2320-01-099-6421
TRUCK, WRECKER-RECOVERY, M984	2320-01-097-0248
TRUCK, WRECKER-RECOVERY, M984A1	2320-01-195-7641
TRUCK, WRECKER-RECOVERY, M984A2	2320-01-492-8224
TRUCK, WRECKER-RECOVERY, M984A2R1	2320-01-492-8233
TRUCK, CARGO, WITH WINCH, M985	2320-01-097-0261
TRUCK, CARGO, WITH WINCH, M985A2	2320-01-492-8214
TRUCK, CARGO, WITH WINCH, M985A2R1	2320-01-493-3787
TRUCK, CARGO, WITHOUT WINCH, M985	2320-01-100-7673
TRUCK, CARGO, WITHOUT WINCH, M985A2	2320-01-492-8201
TRUCK, CARGO, WITHOUT WINCH, M985A2R1	2320-01-493-3789
TRUCK, CARGO, WITH WINCH, M985E1	2320-01-194-7032
TRUCK, CARGO, WITH WINCH, M985E1A2	2320-01-493-3790
TRUCK, CARGO, WITH WINCH, M985E1A2R1	2320-01-493-3792

Approved for public release; distribution is unlimited.

TM 9-2320-279-34-1, June 1987, is changed as follows:

1. Remove old pages and insert new pages as indicated below.
2. New or changed material is indicated by a vertical bar in the margin of the page.
3. Minor changes to illustrations are indicated by a miniature pointing hand.
4. Illustrations that are new or that have major revisions are indicated by a vertical bar adjacent to the illustration identification number.

Remove Pages

A thru C/(D blank)
i and ii
none
2-5 thru 2-8
2-127 thru 2-136
none
Index 1 thru Index 4
Cover

Insert Pages

A thru C/(D blank)
i and ii
ii.1/(ii.2 blank)
2-5 thru 2-8
2-127 thru 2-136
2-136.1 thru 2-136.8
Index 1 thru Index 4
Cover

File this change sheet in front of the publication for reference purposes.

By Order of the Secretary of the Army:

Official:

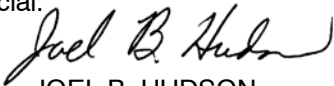

JOEL B. HUDSON

*Administrative Assistant to the
Secretary of the Army
0318303*

PETER J. SCHOOMAKER
*General, United States Army
Chief of Staff*

DISTRIBUTION: To be distributed in accordance with the Initial Distribution Number IDN: 380653, requirements for TM 9-2320-279-34-1.

CHANGE

NO. 5

HEADQUARTERS
DEPARTMENT OF THE ARMY
WASHINGTON, D.C., 15 February, 2002

TECHNICAL MANUAL

MAINTENANCE INSTRUCTIONS

DIRECT SUPPORT AND GENERAL SUPPORT

M977 SERIES, 8 X 8 HEAVY EXPANDED MOBILITY
TACTICAL TRUCKS (HEMTT)

MODEL	NSN
TRUCK, CARGO, WITH WINCH, M977	2320-01-097-0260
TRUCK, CARGO, WITHOUT WINCH, M977	2320-01-099-6426
TRUCK, TANK, FUEL, WITH WINCH, M978	2320-01-097-0249
TRUCK, TANK, FUEL, WITHOUT WINCH, M978	2320-01-100-7672
TRUCK, TRACTOR, WITH WINCH, WITHOUT CRANE, M983	2320-01-097-0247
TRUCK, TRACTOR, WITH WINCH, WITH CRANE, M983	2320-01-099-6421
TRUCK, WRECKER-RECOVERY, M984	2320-01-097-0248
TRUCK, WRECKER-RECOVERY, M984E1	2320-01-195-7641
TRUCK, CARGO, WITH WINCH, M985	2320-01-097-0261
TRUCK, CARGO, WITHOUT WINCH, M985	2320-01-100-7673
TRUCK, CARGO, WITH WINCH, M985E1	2320-01-194-7032
TRUCK, CARGO, WITHOUT WINCH, M985E1	2320-01-194-7031

Approved for public release; distribution is unlimited.

TM 9-2320-279-34-1, June 1987, is changed as follows:

1. Remove old pages and insert new pages as indicated below.
2. New or changed material is indicated by a vertical bar in the margin of the page.
3. Minor changes to illustrations are indicated by a miniature pointing hand.
4. Illustrations that are new or that have major revisions are indicated by a vertical bar adjacent to the illustration identification number.

Remove Pages

i - ii
3-1 - 3-2
3-13 - 3-14
6-1 - 6-2
none
6-15 - 6-18

Insert Pages

i - ii
3-1 - 3-2
3-13 - 3-14
6-1 - 6-2
6-14.1 - 6-14.14
6-15 - 6-18

Remove Pages

6-87 - 6-88
6-95 - 6-96
6-105 - 6-106
6-111 - 6-114
6-119 - 6-120
6-122.13/(6-122.14 blank)
6-123 - 6-124
6-131 - 6-132
6-133/(6-134 blank)
7-67 - 7-72
7-151 - 7-152
7-152.1 - 7-152.2

Insert Pages

6-87 - 6-88
6-95 - 6-96
6-105 - 6-106
6-111 - 6-114
6-119 - 6-120
6-122.13/(6-122.14 blank)
6-123 - 6-124
6-131 - 6-132
6-133/(6-134 blank)
7-67 - 7-72
7-151 - 7-152
7-152.1 - 7-152.2

File this change sheet in front of the publication for reference purposes.

By Order of the Secretary of the Army:

Official:



JOEL B. HUDSON

*Administrative Assistant to the
Secretary of the Army*

0115509

ERIC K. SHINSEKI
*General, United States Army
Chief of Staff*

DISTRIBUTION: To be distributed in accordance with the Initial Distribution Number (IDN) 380653, requirements for TM 9-2320-279-34-1.

CHANGE

NO. 4

HEADQUARTERS
DEPARTMENT OF THE ARMY
WASHINGTON, D.C., 15 December, 2000

TECHNICAL MANUAL
MAINTENANCE INSTRUCTIONS
DIRECT SUPPORT AND GENERAL SUPPORT
M977 SERIES, 8 X 8 HEAVY EXPANDED MOBILITY
TACTICAL TRUCKS (HEMTT)

MODEL	NSN
TRUCK, CARGO, WITH WINCH, M977	2320-01-097-0260
TRUCK, CARGO, WITHOUT WINCH, M977	2320-01-099-6426
TRUCK, TANK, FUEL, WITH WINCH, M978	2320-01-097-0249
TRUCK, TANK, FUEL, WITHOUT WINCH, M978	2320-01-100-7672
TRUCK, TRACTOR, WITH WINCH, WITHOUT CRANE, M983	2320-01-097-0247
TRUCK, TRACTOR, WITH WINCH, WITH CRANE, M983	2320-01-099-6421
TRUCK, WRECKER-RECOVERY, M984	2320-01-097-0248
TRUCK, WRECKER-RECOVERY, M984E1	2320-01-195-7641
TRUCK, CARGO, WITH WINCH, M985	2320-01-097-0261
TRUCK, CARGO, WITHOUT WINCH, M985	2320-01-100-7673
TRUCK, CARGO, WITH WINCH, M985E1	2320-01-194-7032
TRUCK, CARGO, WITHOUT WINCH, M985E1	2320-01-194-7031

Approved for public release; distribution is unlimited.

TM 9-2320-279-34-1, December 1998, is changed as follows:

1. Remove old pages and insert new pages as indicated below.
2. New or changed material is indicated by a vertical bar in the margin of the page.
3. Minor changes to illustrations are indicated by a miniature pointing hand.
4. Illustrations that are new or that have major revisions are indicated by a vertical bar adjacent to the illustration identification number.

Remove Pages

3-29 thru 3-32

Insert Pages

3-29 thru 3-32

File this change sheet in front of the publication for reference purposes.

By Order of the Secretary of the Army:

Official:

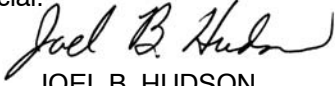

JOEL B. HUDSON
*Administrative Assistant to the
Secretary of the Army*

0026313

ERIC K. SHINSEKI
*General, United States Army
Chief of Staff*

DISTRIBUTION: To be distributed in accordance with the Initial Distribution Number (IDN) 380653, requirements for TM 9-2320-279-34-1.

CHANGE

NO. 3

HEADQUARTERS
DEPARTMENT OF THE ARMY

Washington, D. C., 15 December 1998

TECHNICAL MANUAL

MAINTENANCE INSTRUCTIONS

DIRECT SUPPORT AND GENERAL SUPPORT

M977 SERIES, 8 X 8 HEAVY EXPANDED MOBILITY
TACTICAL TRUCKS (HEMTT)

MODEL	NSN
TRUCK, CARGO, WITH WINCH, M977	2320-01-097-0260
TRUCK,-CARGO, WITHOUT WINCH, M977	2320-01-099-6426
TRUCK, TANK, FUEL, WITH WINCH, M978	2320-01-097-0249
TRUCK, TANK, FUEL, WITHOUT WINCH, M978	2320-01-100-7672
TRUCK, TRACTOR, WITH WINCH, WITHOUT CRANE, M983	2320-01-097-0247
TRUCK, TRACTOR, WITH WINCH, WITH CRANE, M983	2320-01-099-6421
TRUCK, WRECKER-RECOVERY, M984	2320-01-097-0248
TRUCK, WRECKER-RECOVERY, M984E1	2320-01-195-7641
TRUCK, CARGO, WITH WINCH, M985	2320-01-097-0261
TRUCK, CARGO, WITHOUT WINCH, M985	2320-01-100-7673
TRUCK, CARGO, WITH WINCH, M985E1	2320-01-194-7032
TRUCK, CARGO, WITHOUT WINCH, M985E1	2320-01-194-7031

Approved for public release; distribution is unlimited.

TM 9-2320-279-34-1, 3 June 1987, is changed as follows:

1. Remove old pages and insert new pages as indicated below.
2. New or changed material is indicated by a vertical bar in the margin of the page.
3. Minor changes to illustrations are indicated by a miniature pointing hand.
4. Illustrations that are new or that have major revisions are indicated by a vertical bar adjacent to the illustration identification number.
5. Changes on cover are: Removed VOLUME NO. 1, deleted destruction notice, and changed distribution statement.

Remove Pages

c/cd blank)

i thru vi

2-5 and 2-8

2-25 and 2-26

Insert Pages

c/(d blank)

i thru vi

2-5 and 2-8

2-25 and 2-26

Remove Pages

2-81 and 2-82
2-101 and 2-102
none
2-117 thru 2-122
2-127 and 2-128
2-129 thru 2-136
2-137 and 2-138
none
2-139 and 2-140
3-7 and 3-8
3-13 thru 3-16
3-19 and 3-20
3-25 and 3-26
6-1 and 6-2
6-7 and 6-8
6-13 and 6-14
6-91 thru 6-94
6-97 thru 6-100
6-122.1 and 6-122.2
6-122.11 and 6-122.12
7-7 and 7-8
7-10.1/(7-10.2 blank)
7-19 and 7-20
7-23 and 7-24
7-27 and 7-28
7-31 and 7-32
7-37 and 7-38
7-43 thru 7-50
7-53 thru 7-56
7-59 thru 7-64
7-67 thru 7-78
7-81 thru 7-84
none
7-85 thru 7-88
7-91 and 7-92
7-95 thru 7-98
7-99 and 7-100
7-103 thru 7-118
none
7-119 and 7-120
7-123 thru 7-134
7-137 thru 7-157/(7-158 blank)
8-1 thru 8-4
8-7 and 8-8
8-11 and 8-12
8-17 and 8-18
8-21 and 8-22
8-25 thru 8-30
8-33 and 8-34

Insert Pages

2-81 and 2-82
2-101 and 2-102
2-102.1/(2-102.2 blank)
2-117 thru 2-122
2-127 and 2-128/(2-129 through 2-136 deleted)
none
2-137 and 2-138
2-138.1/(2-138.2 blank)
2-139 and 2-140
3-7 and 3-8
3-13 thru 3-16
3-19 and 3-20
3-25 and 3-26
6-1 and 6-2
6-7 and 6-8
6-13 and 6-14
6-91 thru 6-94
6-97 thru 6-100
6-122.1 and 6-122.2
6-122.11 and 6-122.12
7-7 and 7-8
7-10.1/(7-10.2 blank)
7-19 and 7-20
7-23 and 7-24
7-27 and 7-28
7-31 and 7-32
7-37 and 7-38
7-43 thru 7-50
7-53 thru 7-56
7-59 thru 7-64
7-67 thru 7-78
7-81 thru 7-84
7-84.1/(7-84.2 blank)
7-85 thru 7-88
7-91 and 7-92
7-95 thru 7-98
7-99 and 7-100
7-103 thru 7-118
7-118.1/(7-118.2 blank)
7-119 and 7-120
7-123 thru 7-134
7-137 thru 7-157/(7-158 blank)
8-1 thru 8-4
8-7 and 8-8
8-11 and 8-12
8-17 and 8-18
8-21 and 8-22
8-25 thru 8-30
8-33 and 8-34

Remove Pages

8-37 thru 8-44
8-47 thru 8-54
9-3 thru 9-6
9-11 and 9-12
9-15 and 9-16
9-19 and 9-20
none
9-21 and 9-22
9-25 and 9-26
9-35 and 9-36
none
9-37 and 9-38
9-65 and 9-66
9-81 thru 9-84
9-87 and 9-88
9-91 and 9-92
none
DA 2028 sample F & B
DA 2028 F & B
DA 2028 F & B
DA 2028 F & B
Cover

Insert Pages

8-37 thru 8-44
8-47 thru 8-54
9-3 thru 9-6
9-11 and 9-12
9-15 and 9-16
9-19 and 9-20
9-20.1/(9-20.2 blank)
9-21 and 9-22
9-25 and 9-26
9-35 and 9-36
9-36.1/(9-36.2 blank)
9-37 and 9-38
9-65 and 9-66
9-81 thru 9-84
9-87 and 9-88
9-91 and 9-92
9-92.1/(9-91.2 blank)
DA 2028 sample F & B
DA 2028 F & B
DA 2028 F & B
DA 2028 F & B
Cover

File this change sheet in front of the publication for reference purposes.

By Order of the Secretary of the Army:

DENNIS J. REIMER
General, United States Army
Chief of Staff

Official:

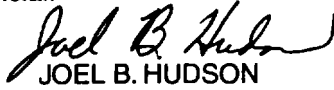

Handwritten signature of Joel B. Hudson in black ink.

JOEL B. HUDSON

Administrative Assistant to the
Secretary of the Army
05642

DISTRIBUTION: To be distributed in accordance with the Initial Distribution Number (IDN) 380653, requirements for TM 9-2320-279-34-1.

CHANGE

NO. 2

HEADQUARTERS
DEPARTMENT OF THE ARMY
Washington D.C., 12 November, 1989

TECHNICAL MANUAL
MAINTENANCE INSTRUCTIONS
DIRECT SUPPORT AND GENERAL SUPPORT
977 SERIES, 8 x 8 HEAVY EXPANDED MOBILITY
TACTICAL TRUCKS (HEMTT)

MODEL	NSN
TRUCK, CARGO, WITH WINCH, M977	2320-01-097-0260
TRUCK, CARGO, WITHOUT WINCH, M977	2320-01-099-6426
TRUCK, TANK, FUEL, WITH WINCH, M978	2320-01-097-0249
TRUCK, TANK, FUEL, WITHOUT WINCH, M978	2320-01-100-7672
TRUCK, TRACTOR, WITH WINCH, WITHOUT CRANE, M963	2320-01-097-0247
TRUCK, TRACTOR, WITH WINCH, WITH CRANE, M983	2320-01-099-6421
TRUCK, WRECKER-RECOVERY, M984	2320-01-097-0248
TRUCK, WRECKER-RECOVERY, M984E1	2320-01-195-7641
TRUCK, CARGO, WITH WINCH, M985	2320-01-097-0261
TRUCK, CARGO, WITHOUT WINCH, M985	2320-01-100-7673
TRUCK, CARGO, WITH WINCH, M985E1	2320-01-194-7032
TRUCK, CARGO, WITHOUT WINCH, M985E1	2320-01-194-7031

TM 9-2320-279-34-1, 3 June 1987, is changed as follows:

1. Remove old pages and insert new pages as indicated below.
2. New or changed material is indicated by a vertical bar in the margin of the page.
3. Minor changes to illustrations are indicated by a miniature pointing hand.
4. Illustrations that are new or that have major revisions are indicated by a vertical bar adjacent to the illustration identification number.

Remove Pages

7-51 and 7-52
7-73 thru 7-76
9-21 and 9-22

Insert Pages

7-51 and 7-52
7-73 thru 7-76
9-21 and 9-22

File this change sheet in front of the publication for reference purposes.

By Order of the Secretary of the Army:

CARL E. VUONO
General, United States Army
Chief of Staff

Official:

R. L. DILWORTH
Brigadier General, United States Army
The Adjutant General

Distribution:

To be distributed in accordance with DA Form 12-38, Direct Support and General Support maintenance requirements for Truck, Cargo, 10-ton, 8x8, Heavy Expanded Mobility Tactical Truck, HEMTT, M977, M978, M983, M984, M985.

CHANGE

NO. 1

HEADQUARTERS
DEPARTMENT OF THE ARMY
Washington, D.C., 28 September 1989

MAINTENANCE INSTRUCTIONS
DIRECT SUPPORT AND GENERAL SUPPORT
M977 SERIES, 8 X 8 HEAVY EXPANDED MOBILITY
TACTICAL TRUCKS (HEMTT)

MODEL	NSN
TRUCK, CARGO, WITH WINCH M977	2320-01-097-0260
TRUCK, CARGO, WITHOUT WINCH M977	2320-01-099-6426
TRUCK, TANK, FUEL, WITH WINCH M978	2320-01-097-0249
TRUCK, TANK, FUEL, WITHOUT WINCH M978	2320-01-100-7672
TRUCK, TRACTOR, WITH WINCH, WITHOUT CRANE M983	2320-01-097-0247
TRUCK, TRACTOR, WITH WINCH, WITH CRANE M983	2320-01-099-6421
TRUCK, WRECKER-RECOVERY M984	2320-01-097-0248
TRUCK, WRECKER-RECOVERY M984E1	2320-01-195-7641
TRUCK, CARGO, WITH WINCH M985	2320-01-097-0261
TRUCK, CARGO, WITHOUT WINCH M985	2320-01-100-7673
TRUCK, CARGO, WITH WINCH M985E1	2320-01-194-7032
TRUCK, CARGO, WITHOUT WINCH M985E1	2320-01-194-7031

TM 9-2320-279-34-1, 3 June 1987 is changed as follows:

1. Remove old pages and insert new pages as indicated below.
2. New or changed material is indicated by a vertical bar in the margin of the page.

Remove Pages

Insert Pages

v through viii

v through viii

File this change sheet in the front of the publication for reference purposes.

By Order of the Secretary of the Army:

Official:

CARL E. VUONO
General, United States Army
Chief of Staff

WILLIAM J. MEEHAN II
Brigadier General, United States Army
The Adjutant General

Distribution:

To be distributed in accordance with DA Form 12-38, Direct Support and General Support maintenance requirements for Truck, Cargo, 10-Ton, 8x8, Heavy Expanded Mobility Tactical Truck, HEMTT, M977, M978, M983, M984, M985.

INSERT LATEST UPDATED PAGES/WORK PACKAGES, DESTROY SUPERSEDED DATE

LIST OF EFFECTIVE PAGES/WORK PACKAGES

NOTE: The portion of text affected by the updates is indicated by a vertical line in the outer margins of the page. Updates to illustrations are indicated by miniature pointing hands. Updates to wiring diagrams are indicated by shaded areas.

Dates of issue for original and updated pages/work packages are:

Original... 0 3 June 1987	Change ... 4 15 December 2000
Change ... 1 28 Sept 1989	Change ... 5 15 February 2002
Change ... 2 12 November 1989	Change ... 6 15 December 2003
Change... 3 15 December 1998	Change... 7 1 July 2005

TOTAL NUMBER OF PAGES IN THIS PUBLICATION IS 780 CONSISTING OF THE FOLLOWING:

Page/WP No.	*Change No.	Page/WP No.	*Change No.	Page/WP No.	*Change No.
Cover	7	2-29 - 2-80	0	3-1	0
Blank	7	2-81	3	3-2	5
a - b	0	2-82 - 2-101	0	3-3 - 3-6	0
c - d	7	2-102	3	3-7	3
i - ii	6	2-102.1	3	3-8 - 3-12	0
ii.1	6	2-102.2 Blank	0	3-13	3
ii.2 blank	6	2-103 - 2-116	0	3-14	5
iii	0	2-117	2	3-15	0
iv - v	3	2-118 - 2-119	0	3-16	3
vi - viii	1	2-120	2	3-17 - 3-19	0
1-1	7	2-121	0	3-20	3
1-2 - 1-8	0	2-122	2	3-21 - 3-24	0
2-1	0	2-123 - 2-126	0	3-25	3
2-2	6	2-126.1 - 2-126.6	0	3-26 - 3-28	0
2-3 - 2-4	0	2-127	0	3-29	4
2-5 - 2-8	6	2-128 - 2-136	6	3-30 - 3-31	0
2-9 - 2-22	0	2-136.1 - 2-136.8	3	3-32	4
2-22.1 - 2-22.2	0	2-137	0	4-1 - 4-3	0
2-23 - 2-24	0	2-138	3	4-4 Blank	0
2-24.1	0	2-138.1	3	5-1 - 5-4	0
2-24.2 Blank	0	2-138.2 Blank	3	6-1	5
2-25	3	2-139	0	6-2	3
2-26 - 2-28	0	2-140	3	6-3 - 6-7	0
2-28.1 - 2-28.8	0				

* Zero in this column indicates an original page.

INSERT LATEST UPDATED PAGES/WORK PACKAGES, DESTROY SUPERSEDED DATE

Page/WP No.	*Change No.	Page/WP No.	*Change No.	Page/WP No.	*Change No.
6-8	3	6-122.11	3	7-56	3
6-9 - 6-13	0	6-122.12	0	7-57 - 7-59	0
6-14	3	6-122.13	5	7-60 - 7-61	3
6-14.1 - 6-14.14	5	6-122.14 Blank	5	7-62	0
6-15	5	6-123	0	7-63 - 7-64	3
6-16	0	6-124	5	7-65 - 7-66	0
6-17	5	6-125 - 6-130	0	7-67	3
6-18 - 6-64	0	6-131 - 6-132	5	7-68 - 7-69	5
6-64.1 - 6-64.6	0	6-133	5	7-70	0
6-65 - 6-70	0	6-134 Blank	5	7-71	5
6-70.1 - 6-70.8	0	7-1 - 7-7	0	7-72	3
6-71 - 6-72	0	7-8	3	7-73	2
6-73	7	7-9 - 7-10	0	7-74 - 7-75	3
6-74 - 6-83	0	7-10.1	3	7-76	0
6-84	7	7-10.2 Blank	3	7-77 - 7-78	3
6-84.1	7	7-11 - 7-19	0	7-79 - 7-80	0
6-84.2 Blank	7	7-20	3	7-81 - 7-84	3
6-85 - 6-86	0	7-21 - 7-22	0	7-84.1	3
6-87	5	7-23	3	7-84.2 Blank	3
6-88 - 6-91	0	7-24 - 7-26	0	7-85	0
6-92 - 6-93	3	7-27	3	7-86	3
6-94 - 6-95	0	7-28 - 7-30	0	7-87	0
6-96	5	7-31	3	7-88	3
6-97	0	7-32	0	7-89 - 7-90	0
6-98 - 6-99	3	7-32.1	0	7-91 - 7-92	3
6-100 - 6-104	0	7-32.2 Blank	0	7-93 - 7-95	0
6-105	5	7-33 - 7-37	0	7-96 - 7-97	3
6-106 - 6-110	0	7-38	3	7-98 - 7-99	0
6-111	5	7-39 - 7-42	0	7-100	3
6-112 - 6-113	0	7-43 - 7-44	3	7-101 - 7-102	0
6-114	5	7-45	0	7-103 - 7-105	3
6-115 - 6-119	0	7-46 - 7-48	3	7-106	0
6-120	5	7-49	0	7-107 - 7-108	3
6-121 - 6-122	0	7-50	3	7-109	0
6-122.1	0	7-51	0	7-110 - 7-115	3
6-122.2	3	7-52	2	7-116 - 7-117	0
6-122.3 -		7-53	3	7-118	3
6-122.10	0	7-54 - 7-55	0	7-118.1	3

* Zero in this column indicates an original page.

INSERT LATEST UPDATED PAGES/WORK PACKAGES, DESTROY SUPERSEDED DATE

Page/WP No.	*Change No.	Page/WP No.	*Change No.	Page/WP No.	*Change No.
7-118.2 Blank	0	8-5 - 8-6	0	9-15	0
7-119 - 7-120	3	8-7	3	9-16	7
7-121 - 7-122	0	8-8	3	9-17 - 9-19	0
7-123	3	8-9 - 8-11	0	9-20	3
7-124	0	8-12	3	9-20.1	3
7-125	3	8-13 - 8-17	0	9-20.2 Blank	3
7-126	0	8-18	3	9-21 - 9-22	3
7-127	3	8-19 - 8-20	0	9-23 - 9-25	0
7-128	0	8-21 - 8-22	3	9-26	3
7-129	3	8-23 - 8-24	0	9-27 - 9-35	0
7-130	0	8-25 - 8-29	3	9-36	3
7-131 - 7-133	3	8-30 - 8-32	0	9-36.1	3
7-134 - 7-137	0	8-33 - 8-34	3	9-36.2 Blank	3
7-138 - 7-140	3	8-35 - 8-37	0	9-37 - 9-38	3
7-141	0	8-38	3	9-39 - 9-64	0
7-142 - 7-145	3	8-39 - 8-40	0	9-65	3
7-146	0	8-41 - 8-43	3	9-66 - 9-81	0
7-147	3	8-44 - 8-46	0	9-82	3
7-148 - 7-149	0	8-47	3	9-83	0
7-150 - 7-151	3	8-48	0	9-84	3
7-152	5	8-49 - 8-53	3	9-85 - 9-86	0
7-152.1 - 7-152.2	5	8-54 - 8-56	0	9-87	3
7-153	3	9-1 - 9-2	0	9-88 - 9-89	0
7-154 - 7-155	0	9-3	3	9-90	7
7-156 - 7-157	3	9-4	0	9-91 - 9-92	3
7-158 Blank	3	9-5	3	9-92.1	3
8-1	0	9-6 - 9-10	0	9-92.2 Blank	3
8-2	3	9-11 - 9-12	3	9-93 - 9-96	0
8-2.1	0	9-13	0	Index 1	6
8-2.2 Blank	0	9-14	7	Index 2	0
8-3	0	9-14.1	7	Index 3	6
8-4	3	9-14.2 Blank	7	Index 4 - Index 10	0

* Zero in this column indicates an original page.

C/(D blank)

TECHNICAL MANUAL

No. 9-2320-279-34-1

HEADQUARTERS
DEPARTMENT OF THE ARMY
Washington, DC, 3 June 1987

MAINTENANCE INSTRUCTIONS

DIRECT SUPPORT AND GENERAL SUPPORT

M977 SERIES, 8 X 8 HEAVY EXPANDED MOBILITY
TACTICAL TRUCKS (HEMTT)

MODEL	NSN
TRUCK, CARGO, WITH WINCH, M977	2320-01-097-0260
TRUCK, CARGO, WITH WINCH, M977A2	2320-01-493-3774
TRUCK, CARGO, WITH WINCH, M977A2R1	2320-01-493-3782
TRUCK, CARGO, WITHOUT WINCH, M977	2320-01-099-6426
TRUCK, CARGO, WITHOUT WINCH, M977A2	2320-01-493-3779
TRUCK, CARGO, WITHOUT WINCH, M977A2R1	2320-01-493-3785
TRUCK, TANK, FUEL, WITH WINCH, M978	2320-01-097-0249
TRUCK, TANK, FUEL, WITH WINCH, M978A2	2320-01-492-8216
TRUCK, TANK, FUEL, WITH WINCH, M978A2R1	2320-01-492-8226
TRUCK, TANK, FUEL, WITHOUT WINCH, M978	2320-01-100-7672
TRUCK, TANK, FUEL, WITHOUT WINCH, M978A2	2320-01-492-8215
TRUCK, TANK, FUEL, WITHOUT WINCH, M978A2R1	2320-01-492-8225
TRUCK, TRACTOR, WITH WINCH, WITHOUT CRANE, M983	2320-01-097-0247
TRUCK, TRACTOR, WITH WINCH, WITHOUT CRANE, M983A2	2320-01-492-8223
TRUCK, TRACTOR, WITH WINCH, WITHOUT CRANE, M983A2R1	2320-01-492-8231
TRUCK, TRACTOR, WITH WINCH, WITH CRANE, M983	2320-01-099-6421
TRUCK, WRECKER-RECOVERY, M984	2320-01-097-0248
TRUCK, WRECKER-RECOVERY, M984A1	2320-01-195-7641
TRUCK, WRECKER-RECOVERY, M984A2	2320-01-492-8224
TRUCK, WRECKER-RECOVERY, M984A2R1	2320-01-492-8233
TRUCK, CARGO, WITH WINCH, M985	2320-01-097-0261
TRUCK, CARGO, WITH WINCH, M985A2	2320-01-492-8214
TRUCK, CARGO, WITH WINCH, M985A2R1	2320-01-493-3787
TRUCK, CARGO, WITHOUT WINCH, M985	2320-01-100-7673
TRUCK, CARGO, WITHOUT WINCH, M985A2	2320-01-492-8201
TRUCK, CARGO, WITHOUT WINCH, M985A2R1	2320-01-493-3789
TRUCK, CARGO, WITH WINCH, M985E1	2320-01-194-7032
TRUCK, CARGO, WITH WINCH, M985E1A2	2320-01-493-3790
TRUCK, CARGO, WITH WINCH, M985E1A2R1	2320-01-493-3792

Approved for public release; distribution is unlimited.

REPORTING ERRORS AND RECOMMENDING IMPROVEMENTS

You can help improve this publication. If you find any mistakes or if you know of a way to improve the procedures, please let us know. Submit your DA Form 2028 (Recommended Changes to Equipment Technical Publications), through the Internet, on the Army Electronic Product Support (AEPS) Web site. The Internet address is <http://aeeps.ria.army.mil>. If you need a password, scroll down and click on "ACCESS REQUEST FORM." The DA Form 2028 is located in the ONLINE FORMS PROCESSING section of the AEPS. Fill out the form and click on SUBMIT. Using this form on the AEPS will enable us to respond quicker to your comments and better manage the DA Form 2028 program. You may also mail, fax, or e-mail your letter or DA Form 2028 direct to: AMSTA-LC-CI/TECH PUBS, TACOM-RI, 1 Rock Island Arsenal, Rock Island, IL 61299-7630. The e-mail address is TACOM-TECH-PUBS@ria.army.mil. The fax number is DSN 793-0726 or Commercial (309) 782-0726.

M983 with crane and M985E1 without winch are no longer in the fleet. Ignore all references to these vehicles. The M984E1 and M984A1 are the same vehicle. All references to M984E1 shall be interpreted as the M984A1 model. All references to M977 series vehicles shall be interpreted to include A2 and A2R1 models, unless otherwise noted.

TABLE OF CONTENTS

	Page
HOW TO USE THIS MANUAL	vii
CHAPTER 1 INTRODUCTION	1-1
Section I General Information	1-1
Section II Equipment Description and Data	1-7
Section III Principles of Operation	1-8
CHAPTER 2 MAINTENANCE INSTRUCTIONS	2-1
Section I Introduction	2-1
Section II Repair Parts, Special Tools, and Test, Measurement and Diagnostic Equipment (TMDE) and Support Equipment	2-1
Section III Troubleshooting	2-2
Section IV Maintenance Procedures	2-137
CHAPTER 3 ENGINE MAINTENANCE	3-1
Section I Introduction	3-1
Section II Service and Inspection	3-1
Section III Engine Assembly	3-2
CHAPTER 4 FUEL SYSTEM MAINTENANCE	4-1
Section I Introduction	4-1
Section II Throttle Treadle Valve	4-1
CHAPTER 5 COOLING SYSTEM MAINTENANCE	5-1
Section I Introduction	5-1
Section II Radiator	5-1

TABLE OF CONTENTS (CONT)

	Page
CHAPTER 6 ELECTRICAL SYSTEM MAINTENANCE	6-1
Section I Introduction	6-1
Section II Alternator and Starter	6-2
Section III Crane System Electrical	6-36
Section IV Wiring Harnesses	6-70.8
CHAPTER 7 TRANSMISSION MAINTENANCE	7-1
Section I Introduction	7-1
Section II Service and Inspection	7-1
Section III Shift Tower	7-3
Section IV Transmission Assembly	7-8
Section V Oil Pan and Internal Oil Filter	7-72
Section VI Gear Unit and Main Shaft	7-77
Section VII Clutch Assemblies	7-91
Section VIII Valve Bodies and Governor	7-135
CHAPTER 8 TRANSFER CASE MAINTENANCE	8-1
Section I Introduction	8-1
Section II Transfer Case Assembly	8-2
Section III Transfer Case Controls	8-44
Section IV Lubrication Pump	8-52
CHAPTER 9 AXLES NO. 1. AND NO. 2 MAINTENANCE	9-1
Section I Introduction	9-1
Section II Axle Assemblies	9-2
Section III Differential Carriers	9-19
Section IV Ball Sockets	9-82
CHAPTER 10 AXLES NO. 3 AND NO. 4 MAINTENANCE	10-1
Section I Introduction	10-1
Section II Axle Assemblies	10-1
Section III Differential Carriers	10-15

TABLE OF CONTENTS (CONT)

	Page
CHAPTER 11 BRAKE SYSTEM MAINTENANCE	11-1
Section I Introduction	11-1
Section II Service Brakes	11-1
Section III Air Brake System	11-5
Section IV Air Compressor	11-18
Section V Trailer Brake System	11-33
CHAPTER 12 STEERING SYSTEM MAINTENANCE	12-1
Section I Introduction	12-1
Section II Steering Linkage and Gearbox	12-1
Section III Steering Gear and Slave	12-19
Section IV Steering Pump	12-42
Section V Steering System Adjustments	12-48.13
CHAPTER 13 FRAME MAINTENANCE	13-1
Section I Introduction	13-1
Section II Frame Assembly	13-2
Section III Fifth Wheel Assembly	13-91
CHAPTER 14 SUSPENSION MAINTENANCE	14-1
Section I Introduction	14-1
Section II Spring Assembly	14-1
Section III Lateral Torque Rod and Equalizer Beams	14-11
CHAPTER 15 CAB AND BODY MAINTENANCE	15-1
Section I Introduction	15-1
Section II Cab Assembly	15-2
Section III Pump Module, Tank, and Cargo Bodies	15-26
CHAPTER 16 WINCH MAINTENANCE	16-1
Section I Introduction	16-1
Section II Self-Recovery Winch	16-2
Section III Heavy-Duty Winch	16-22
CHAPTER 17 M977 AND M985 CRANE MAINTENANCE	17-1
Section I Introduction	17-1
Section II Crane, Subframe, and Swing Drive	17-2
Section III Boom, Mast, and Extensions	17-50.10
Section IV Cylinders	17-70
Section V Hoist	17-93
Section VI Crane Control Systems	17-119
Section VII Outriggers	17-156
CHAPTER 18 Deleted	

TABLE OF CONTENTS (CONT)

	Page
CHAPTER 19 POWER TAKEOFF (PTO) AND HYDRAULIC PUMP MAINTENANCE	19-1
Section I Introduction	19-1
Section II Power Take off (PTO)	19-1
Section III Hydraulic Pump	19-12.10
CHAPTER 20 HYDRAULIC SYSTEM MAINTENANCE	20-1
Section I Introduction	20-1
Section II Hydraulic Hand Pump	20-1
Section III Hydraulic Control Valve	20-5
CHAPTER 21 ARCTIC HEATER KIT MAINTENANCE	21-1
Section I Introduction	21-1
Section II Arctic Heater Kit	21-1
CHAPTER 22 M978 TANKER MAINTENANCE	22-1
Section I Introduction	22-1
Section II Service and Inspection	22-2
Section III Pump, Pump Motor, and Auxiliary Pump	22-10
Section IV Flow Meter	22-31
Section V Air Eliminator	22-44
Section VI Valves	22-47
Section VII Fuel Service Nozzle	22-105
CHAPTER 23 SPECIAL PURPOSE KIT INSTALLATION	23-1
Section I Introduction	23-1
Section II Arctic Heater	23-1
Section III Armament Equipment	23-25
Section IV Radio	23-33
Section V Chemical, Biological, and Radiological (CBR) Equipment	23-40
APPENDIXES	
A REFERENCES	A-1
B ILLUSTRATED LIST OF MANUFACTURED ITEMS	B-1
C EXPENDABLE SUPPLIES AND MATERIALS LIST	C-1
D TORQUE LIMITS	D-1
INDEX	Index 1

LIST OF ILLUSTRATIONS

Figure	Title	Page
1-1	M977 Cargo Vehicle	1-2
1-2	M978 Fuel Tanker Vehicle	1-2
1-3	M983 Tractor Vehicle with Material Handling Crane	1-3
1-4	M983 Tractor Vehicle without Material Handling Crane	1-3
1-5	M984 Wrecker-Recovery Vehicle	1-4
1-6	M984A1 Wrecker-Recovery Vehicle	1-4

LIST OF ILLUSTRATIONS (CONT)

Figure	Title	Page
1-7	M985 Cargo Vehicle	1-5
1-8	M985E1 Cargo Vehicle	1-5
2-1	STE/ICE Connector	2-1
2-2	Main Control Valve (M983)	2-29
2-3	Outrigger Control Valve (M983)	2-30
2-4	System Back Pressure (No Load) (M983)	2-31
2-5	Pressure Tester Setup (M983)	2-33
2-6	Power Distribution Board Wiring Diagram (M983)	2-62
2-7	12V Electric Motors Test Circuit Schematic (M983)	2-64
2-8	12V Electric Motors Tester Circuit Wiring Diagram (M983)	2-65
2-9	Arctic Coolant Pump Test	2-128
17-1	Hoist Hoses and Tubes (Left Side)	17-5
17-2	Hoist Hoses and Tubes (Right Side)	17-6
17-3	Telescoping Cylinders, Hoses, and Tubes	17-7
17-4	Telescoping Cylinders, Hoses, and Tubes	17-8
17-5	Boom Cylinders, Hoses, and Tubes	17-9
17-6	Boom Cylinders, Hoses, and Tubes	17-10
17-7	Mast Erection Cylinders, Hoses, and Tubes	17-11
17-8	Swing Drive Hoses and Tubes	17-12
17-9	Main Hydraulic Hoses and Tubes	17-13
17-10	Main Control Valve	17-15
17-11	Overload Solenoid (M977 Only)	17-16
17-12	Hoist Hoses and Tubes (Left Side)	17-16.4
17-13	Hoist Hoses and Tubes (Right Side)	17-16.5
17-14	Lift Cylinder..	17-16.6
17-15	Swing Drive	17-16.7
17-16	Main Lines	17-16.8
17-17	Shutdown Valves..	17-16.9
17-18	Shutdown Valves..	17-16.10
17-19	Accumulator	17-16.11
17-20	Control Valve	17-16.12
17-21	Control Valve	17-16.13
17-22	Control Valve	17-16.14
17-23	Left Hand Valve	17-16.15
17-24	Outrigger Manifold	17.16.16
17-25	Outrigger Cylinders	17-16.17
18-1	Extensions No. 3 and No. 4 Hoses and Tubes (Hose Reel Side)	18-79
18-2	Extensions No. 3 and No. 4 Hoses and Tubes (Hose Reel Side)	18-80
18-3	Extensions No. 1 and No. 2 Hoses and Tubes (Hose Reel Side)	18-81
18-4	Extensions No. 1 and No. 2 Hoses and Tubes (Hoist Cable Tiedown Block Side) ...	18-82
18-5	Extensions No. 1 and No. 2 Hoses and Tubes.	18-83
18-6	Hoist Hoses and Tubes (Hose Reel Side)	18-84
18-7	Hoist Hoses and Tubes (Hose Reel Side)	18-85
18-8	Hoist Hoses and Tubes (Hoist Cable Tiedown Block Side)	18-87
18-9	Inner Boom Hoses and Tubes	18-88
18-10	Unfolding Cylinders Hoses and Tubes	18-89
18-11	Main Hydraulic Tubes	18-91
18-12	Slewing System Tubes	18-93
18-13	Outrigger Control Tubes	18-94
18-14	Outrigger Hoses and Tubes	18-95
18-15	Main Control Valve Ports	18-96
22-1	Tanker External Components	22-5
22-2	Tanker Filter and Manual Dispensing Components	22-6
22-3	Tanker Dispensing Components-Valves.	22-7
22-4	Tanker Loading and Unloading Components	22-8
22-5	Tanker Gages, Air, and Electrical Components	22-9

LIST OF ILLUSTRATIONS (CONT)

Figure	Title	Page
B-1	Lifting Eyes (PN 2BH944)	B-2
B-2	Shims	B-2
B-3	Detent Ball Compression Tool (Heavy-Duty Winch) (PN IPP161)	B-3
B-4	Crane Hoist Drive Unit Pressure Plate Removal/Installation Tool (M983)	B-3
B-5	Arctic Heater Test Set.	B-4
B-6	Valve Seat Tool (M983) (PN 2CS30)	B-6
B-7	Seal Retainer Tool (M983) (PN 2CS31)	B-6
B-8	V5 Air Actuated Valve Spring Compression Tool (M978) (PN 2SK886).	B-7
B-9	Air Compressor Unloader Bore Bushing Removal Tool (PN 2BF829)	B-9
B-10	Air Compressor Cylinder Head Removal Tool (PN 2AH762)	B-10
B-11	Spanner Socket	B-11
B-12	Hoses and Hose Assemblies	B-14
B-13	Locking Strips.. . . .	B-17
B-14	Locking Channel	B-18
B-15	Harness Wire	B-18
FO-1	Hydraulic Schematic	FP-1
FO-2	Crane Wiring Diagrams.	FP-23
FO-3	Crane Electrical Schematic.	FP-29

LIST OF TABLES

Number	Title	Page
1-1	Nomenclature Cross-Reference	1-6
1-2	Significant Hazards and Safety Recommendations.	1-7
2-1	Troubleshooting Fault Symptom Index	2-2
2-2	Troubleshooting Subject Index.	2-5
2-3	Troubleshooting	2-10
7-1	Valve Spring Load-Height Specifications.	7-65
7-2	Spring Load-Length Specifications.	7-161
16-1	Compression Spring, Poppet Spring, and Spool Spring Load-Height Specifications	16-59
17-1	Hoist Hoses and Tubes (Left Side)	17-5
17-2	Hoist Hoses and Tubes (Right Side)	17-6
17-3	Telescoping Cylinders, Hoses, and Tubes.	17-7
17-4	Telescoping Cylinders, Hoses, and Tubes.	17-8
17-5	Boom Cylinders, Hoses, and Tubes	17-9
17-6	Boom Cylinders, Hoses, and Tubes	17-10
17-7	Mast Erection Cylinders, Hoses, and Tubes	17-11
17-8	Swing Drive Hoses and Tubes.	17-12
17-9	Main Hydraulic Hoses and Tubes	17-13
17-10	Main Control Valve	17-14
17-11	Overload Solenoid (M977 Only)	17-16
17-12	Hoist Hoses and Tubes (Left Side)	17-16.3
17-13	Hoist Hoses and Tubes (Right Side)	17-16.5
17-14	Lift Cylinder.	17-16.6
17-15	Swing Drive	17-16.7
17-16	Main Lines.. . . .	17-16.8
17-17	Shutdown Valves	17-16.9
17-18	Shutdown Valves	17-16.10
17-19	Accumulator	17-16.11
17-20	Control Valve	17-16.12
17-21	Control Valve	17-16.13
17-22	Control Valve	17-16.14
17-23	Left Hand Valve	17-16.15
17-24	Outrigger Manifold	17-16.6
17-25	Outrigger Cylinders.	17-16.17

LIST OF TABLES (CONT)

Number	Title	Page
18-1	Extensions No. 3 and No. 4 Hoses and Tubes (Hose Reel Side)	18-79
18-2	Extensions No. 3 and No. 4 Hoses and Tubes (Hose Reel Side)	18-80
18-3	Extensions No. 1 and No. 2 Hoses and Tubes (Hose Reel Side)	18-81
18-4	Extensions No. 1 and No. 2 Hoses and Tubes (Hoist Cable Tiedown Block Side).	18-82
18-5	Extensions No. 1 and No. 2 Hoses and Tubes	18-83
18-6	Hoist Hoses and Tubes (Hose Reel Side)	18-84
18-7	Hoist Hoses and Tubes (Hose Reel Side)	18-85
18-8	Hoist Hoses and Tubes (Hoist Cable Tiedown Block Side)	18-86
18-9	Inner Boom Hoses and Tubes	18-88
18-10	Unfolding Cylinders Hoses and Tubes	18-89
18-11	Main Hydraulic Tubes	18-90
18-12	Slewing System Tubes	18-92
18-13	Outrigger Control Tubes	18-94
18-14	Outrigger Hoses and Tubes	18-95
18-15	Main Control Valve Ports	18-96
B-1	Hoses and Hose Assemblies	B-14
B-2	Locking Strips	B-17
B-3	Locking Channel	B-18
B-4	Harness Assembly	B-18
D-1	Torque Limits for Dry Fasteners	D-2
D-2	Torque Limits for Wet Fasteners	D-3
D-3	Dry Torque Limits for M983 Crane (Metric)	D-4

HOW TO USE THIS MANUAL

This manual is designed to help maintain the M977 series vehicles. In addition to this manual TM 9-2320-354-24&P provides additional unique maintenance instructions for the M984 with HIAB 8109 crane and TM 9-2320-355-24&P provides additional unique maintenance instructions for the M985E1 with HIAB 8108 crane. Listed below are some of the special features which have been put into help locate and use needed information.

- The front cover index provides a quick reference to chapters and sections that will be used often.
- The appendixes are located at the end of the manual. They contain a reference guide to other manuals, a manufactured items list, a list of expendable supplies and materials, and tables for torque values.
- Subject headings and certain other essential information are printed in bold type throughout the manual to make them more visible.
- The maintenance tasks describe what must be done to the vehicle before starting the task, and what must be done to return the vehicle to operating condition after the task is finished.

The manual is divided into chapters containing direct support and general support maintenance procedures. These procedures describe a number of things such as:

- What will be needed to do the job.
- If any assistance will be needed.
- How long the job will take.
- Important safety precautions.

In addition to the text, there will be an exploded-view illustration of most steps. This illustration is keyed to the text and shows you how to take the part off and put it on. Cleaning and inspection procedures are also included when required. The following problem will describe some of the features of this manual.

PROBLEM

The vehicle operator brings an M977 vehicle into the shop with a problem. Whenever the crane is operated, the remote controller will not operate the crane. Organizational maintenance troubleshooting has been completed and trouble has not been fixed.

1. How do you start?

Look at the cover of the manual.

On the cover is a listing of different sections in the manual. It will be necessary to troubleshoot the problem to find the cause, so the Troubleshooting section will be needed. Open the manual to the page stated on the cover, or to find the Troubleshooting section fast, bend the pages slightly and line up the troubleshooting block on the cover with the black tab on the pages. The manual will be opened to Section III of Chapter 2, Troubleshooting.

2. What kind of problem is it?

Find it in the symptom index.

There are two symptom indexes in the Troubleshooting section. One is arranged alphabetically by **fault symptom** and the other is arranged alphabetically by **subject/symptom**. The symptom causing the problem might be in the Troubleshooting Fault Symptom Index under Material Handling Crane or Hydraulic System. In the Subject/Symptom Index, it might be under Remote Controller, or Crane. When the symptom to the problem is found, go to the troubleshooting procedure page listed for that symptom. For example, look for "Remote Controller will not operate crane."

3. How can the cause of the problem be determined?

Go to page 2-83.

Troubleshooting for CRANE WILL NOT OPERATE MANUALLY OR WITH REMOTE CONTROLLER is on that page. The troubleshooting procedures have columns with the headings: MALFUNCTION, TEST OR INSPECTION, and CORRECTIVE ACTION. Starting at step 1, read the procedure. Each step describes what to do and what to look for. Follow the steps, in order, to troubleshoot the symptom until the problem is found. When the problem is found, the CORRECTIVE ACTION column will describe how to fix it.

4. Let's assume it was determined that the two-way solenoid valve is bad. The replacement is in paragraph 17-32.

The procedure contains all the information needed to replace the two-way solenoid valve. First, check the introductory material. It tells what will be needed before starting the job. Following the introductory material is an exploded-view illustration and step-by-step instructions which show how to remove and install the two-way solenoid valve.

FOLLOW THESE GUIDELINES WHEN USING THIS MANUAL:

- Become familiar with the entire maintenance procedure before beginning a maintenance task.
- Read all WARNINGS and CAUTIONS before performing any procedures.

CHAPTER 1 INTRODUCTION

Contents	Para	Page
Scope	1-1	1-1
Maintenance Forms, Records, and Reports	1-2	1-5
Destruction of Army Material to Prevent Enemy Use	1-3	1-5
Preparation for Storage or Shipment	1-4	1-6
Nomenclature Cross-Reference	1-5	1-6
Reporting Equipment Improvement Recommendations (EIR)	1-6	1-6
Equipment Improvement Report and Maintenance Digest (EIR MD) and Equipment Improvement Report and Maintenance Summary (EIR MS)	1-7	1-6
Warranty Information	1-8	1-6
Metric System	1-9	1-6
Vehicle Description	1-10	1-7
Equipment Characteristics, Capabilities, and Features	1-11	1-7
Location and Description of Components	1-12	1-7
Differences Between Models	1-13	1-7
Safety, Care, and Handling	1-14	1-7
Principles of Operation	1-15	1-8

Section I. GENERAL INFORMATION

Vehicle Models

1-1. SCOPE. This chapter provides general information, equipment description, and principles of operation for the M977 series vehicles.

a. Type of Manual: Direct Support and General Support Maintenance Instructions, TM9-2320-279-34.

b. Model Numbers and Equipment Names. The different vehicle models are listed below:

M977:	Cargo vehicle, with self-recovery winch (fig. 1-1). Cargo vehicle, without self-recovery winch.
M978:	Fuel tanker vehicle, with self-recovery winch (fig. 1-2). Fuel tanker vehicle, without self-recovery winch.
M983:	Tractor vehicle, with self-recovery winch and material handling crane (fig. 1-3). Tractor vehicle, with self-recovery winch, without material handling crane (fig 1-4).
M984:	Wrecker-recovery vehicle (fig. 1-5).
M984A1:	Wrecker-recovery vehicle (fig. 1-6).
M985:	Cargo vehicle, with self-recovery winch (fig. 1-7). Cargo vehicle, without self-recovery winch.
M985E1:	Cargo vehicle, with self-recovery winch (fig. 1-8). Cargo vehicle, without self-recovery winch.

c. Purpose of Equipment. The M977 series vehicles are a family of 8 x 8 vehicles for tactical use. The purposes of the vehicles are as follows.

- (1) The M977 cargo vehicle is used for ammunition and other resupply missions.
- (2) The M978 tanker vehicle is used to refuel wheel and track vehicles and for other fuel resupply missions.
- (3) The M983 tractor is used to transport Patriot missiles.
- (4) The M984 and M984A1 wrecker-recovery vehicles are the prime recovery vehicles of the M977 series.
- (5) The M985 cargo vehicle is used to resupply the Multiple Launch Rocket System (MLRS).
- (6) The M985E1 cargo vehicle is used to resupply the Patriot Missile System.

Vehicle Models (Cont)

1-1. SCOPE (CONT).

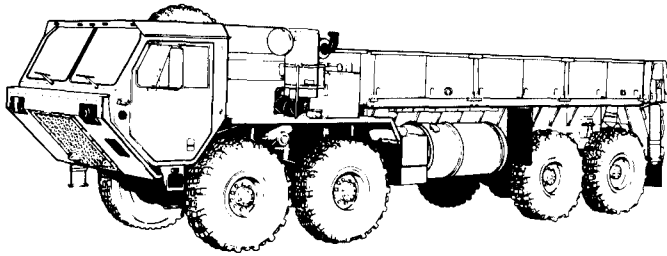

LEFT FRONT VIEW

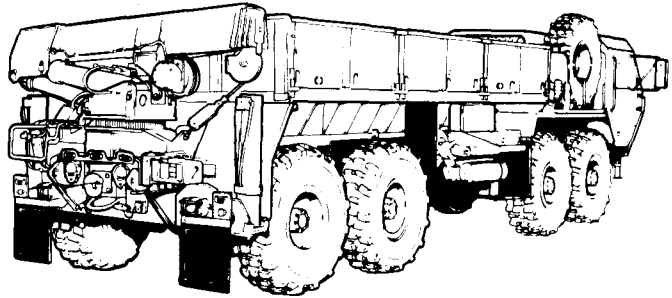

RIGHT REAR VIEW

TA357324

Figure 1-1. M977 Cargo Vehicle.

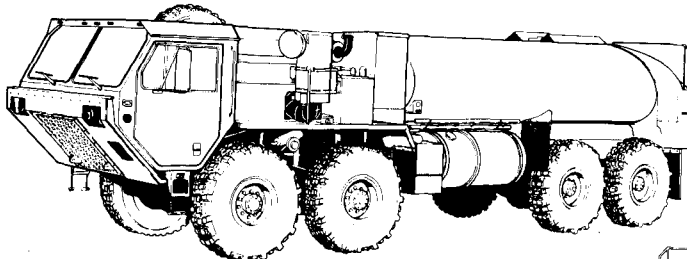

LEFT FRONT VIEW

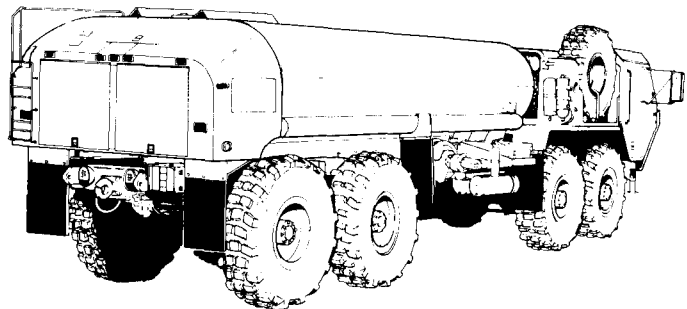

RIGHT REAR VIEW

TA357325

Figure 1-2. M978 Fuel Tanker Vehicle.

Vehicle Models (Cont)

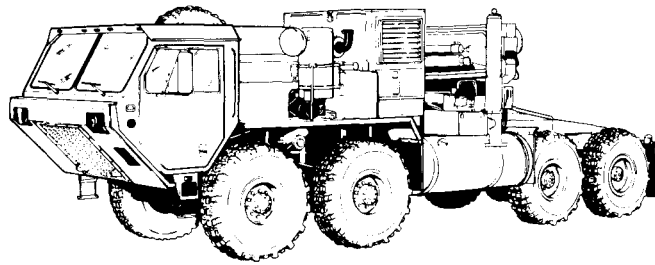

LEFT FRONT VIEW

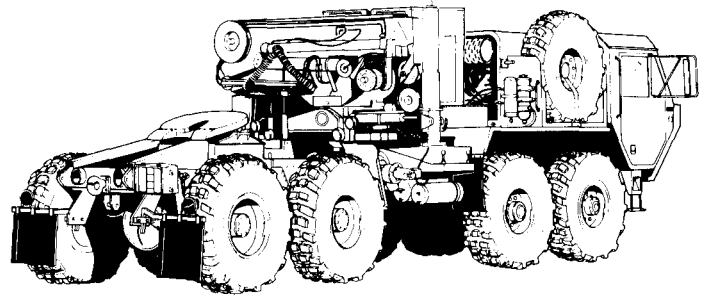

RIGHT REAR VIEW

TA357326

Figure 1-3. M983 Tractor Vehicle with Crane.

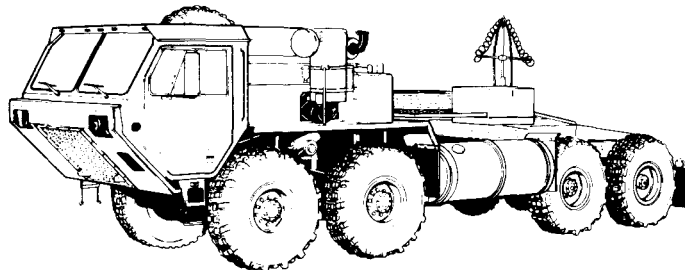

LEFT FRONT VIEW

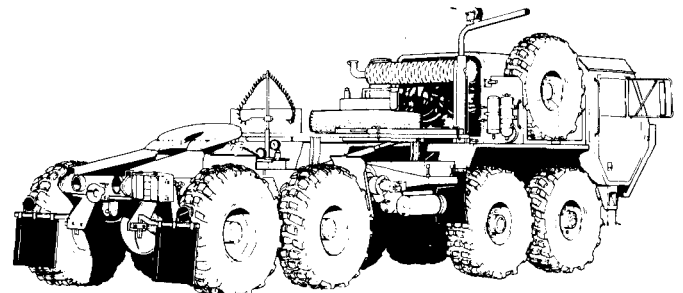

RIGHT REAR VIEW

TA357327

Figure 1-4. M983 Tractor Vehicle without Crane.

Vehicle Models (Cont)

1-1. SCOPE (CONT).

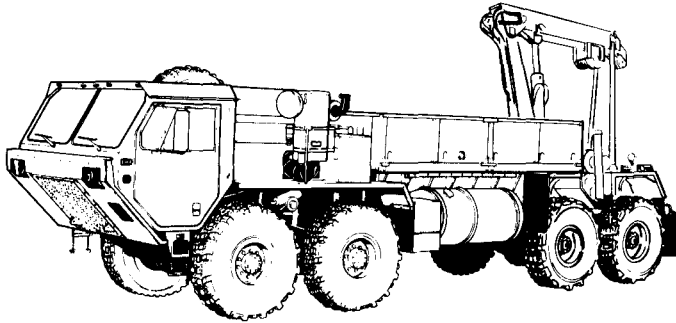

LEFT FRONT VIEW

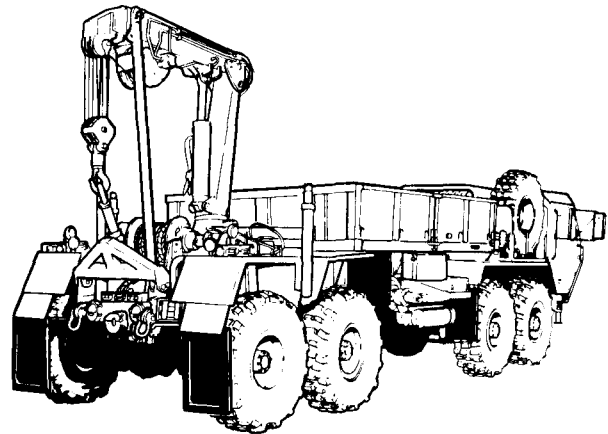

RIGHT REAR VIEW

TA357328

Figure 1-5. M984 Wrecker-Recovery Vehicle.

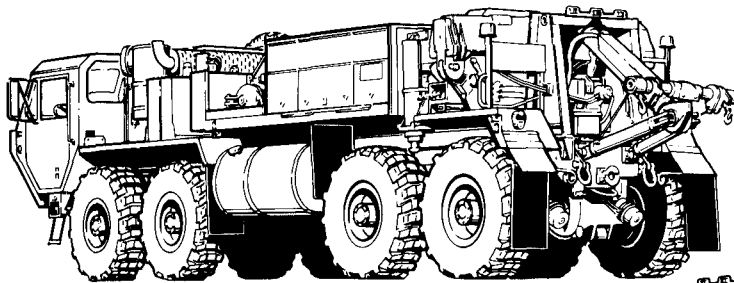

LEFT REAR VIEW

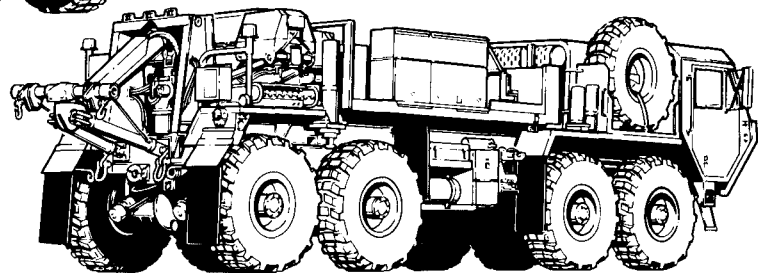

RIGHT REAR VIEW

TA357329

Figure 1-6. M984E1 Wrecker-Recovery Vehicle.

Vehicle Models (Cont)

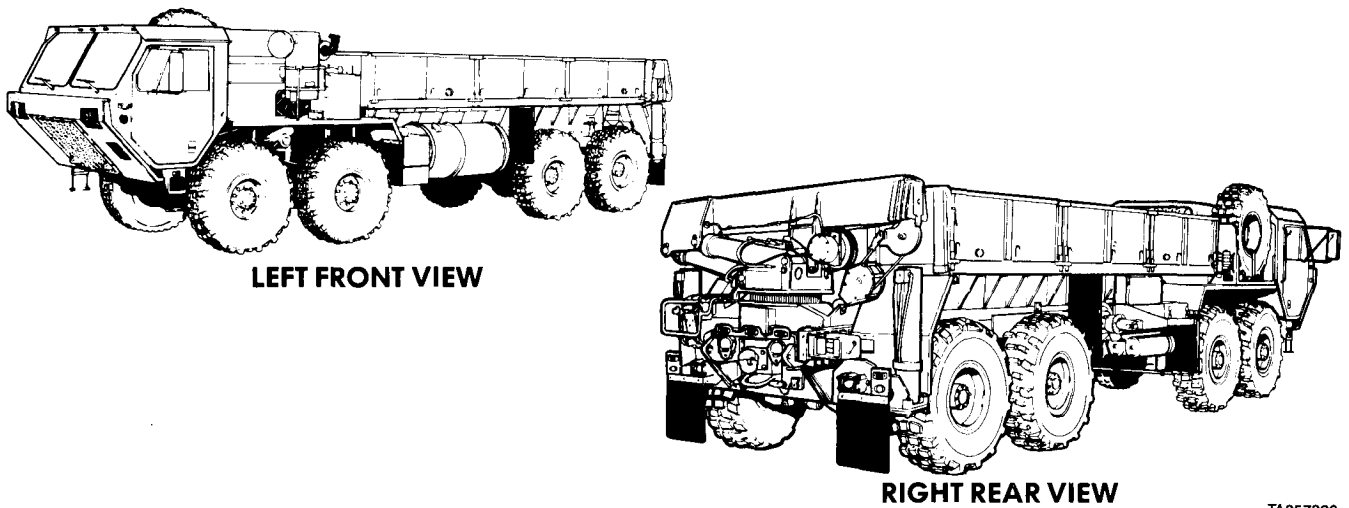

TA357330

Figure 1-7. M985 Cargo Vehicle.

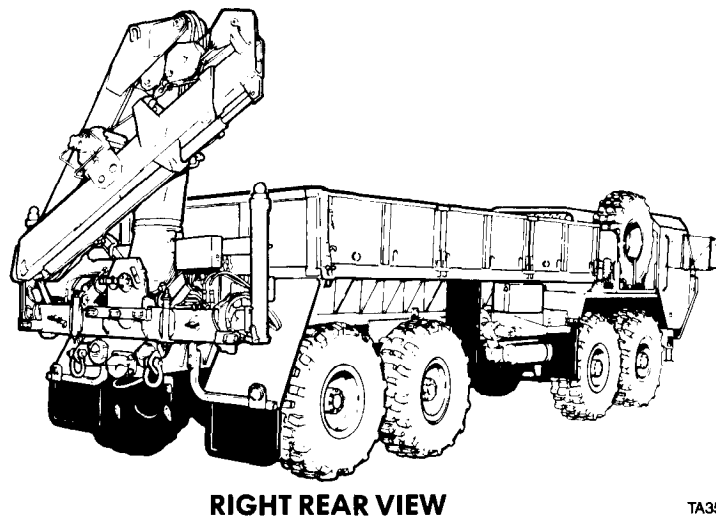

TA357331

Figure 1-8. M985E1 Cargo Vehicle.

Equipment and Maintenance Reports

1-2. MAINTENANCE FORMS, RECORDS, AND REPORTS. Department of the Army forms and procedures used for equipment maintenance will be as specified in the latest edition of DA PAM 738-750, The Army Maintenance Management System (TAMMS).

1-3. DESTRUCTION OF ARMY MATERIEL TO PREVENT ENEMY USE. Command decision, according to the tactical situation, will determine when the destruction of the M977 series vehicles will be accomplished. A destruction plan will be prepared by the using organization unless one has been prepared by a higher authority. For general destruction procedures for this equipment, refer to TM 750-244-6, Procedures for Destruction of Tank-Automotive Equipment to Prevent Enemy Use (U.S. Army Tank-Automotive Command).

Equipment and Maintenance Reports (Cont)

1-4. PREPARATION FOR STORAGE OR SHIPMENT Instructions for preparation for storage or shipment are provided in TM 9-2320-279-20.

1-5. NOMENCLATURE CROSS-REFERENCE Table 1-1 lists the nomenclature cross-references used in this manual.

Table 1-1. Nomenclature Cross-Reference

Common Name	Official Nomenclature
O-ring	Preformed packing
Snap ring	Retaining ring
Engine coolant	Antifreeze, ethylene glycol mixture
Cold start system	Ether quick-start system
Jake brake, Jacobs® brake	Engine retarder
Cable	Wire rope
Glad hand	Quick disconnect coupling

1-6. REPORTING EQUIPMENT IMPROVEMENT RECOMMENDATIONS (EIR). If any vehicle needs improvement, let us know. Send us an EIR. The user is the only one who can tell us how the equipment might be improved. Let us know what isn't liked about the design. Put it on an SF 368 (Quality Deficiency Report). Mail it to us at: Commander, U.S. Army Tank-Automotive Command, ATTN: AMSTA-QRT, Warren, MI 48397-5000. We'll send a reply.

1-7. EQUIPMENT IMPROVEMENT REPORT AND MAINTENANCE DIGEST (EIR MD) AND EQUIPMENT IMPROVEMENT REPORT AND MAINTENANCE SUMMARY (EIR MS).
 The quarterly Equipment Improvement Report and Maintenance Digest, TB 43-0001-39 series, contains valuable field information on the equipment covered in this manual. The information in the TB 43-0001-39 series is compiled from some of the Quality Deficiency Reports that have been prepared on the vehicles covered in this manual. Many of these articles result from comments, suggestions, and improvement recommendations that were submitted to the EIR program. The TB 43-0001-39 series contains information on equipment improvements, minor alterations, proposed Modification Work Orders (MWO's), warranties (if applicable), actions taken on some of the DA Form 2028's (Recommended Changes to Publications), and advance information on proposed changes that may affect this manual. In addition, the more maintenance significant articles, including minor alterations, field-fixes, etc., that have a more permanent and continuing need in the field are republished in the Equipment Improvement Report and Maintenance Summary (EIR MS) for TACOM Equipment (TM 43-1043). Refer to both of these publications (TB 43-0001-39 series and TM 43-1043) periodically, especially the TB 43-0001-39 series, for most current and authoritative information on the equipment. The information will help to do a better job and will advise of the latest changes to this manual. Also refer to DA Pam 310-1, Consolidated Index of Army Publications and Blank Forms, and Appendix A, References, of this manual.

1-8. WARRANTY INFORMATION. The M977 series vehicles are warranted by Oshkosh Truck Corporation for 12 months or 12,000 miles (19 308 km), whichever comes first. For complete information covering this warranty, refer to Warranty Technical Bulletin, TB 9-2300-295-15/19. Warranty starts on the date found in block 23, DA Form 2408-9, in the logbook. Report all defects in material or workmanship to the supervisor, who will take appropriate action.

1-9. METRIC SYSTEM. The equipment described herein contains metric components and requires metric common and special tools; therefore, metric units in addition to English units will be used throughout this manual. An English-to-metric conversion table is included as the last page of this manual inside the back cover.

Section II. EQUIPMENT DESCRIPTION AND DATA

Features and Technical Data

1-10. VEHICLE DESCRIPTION. The M977 series vehicles are 8x8, on/off road vehicles produced in a number of different configurations. For equipment operation data, refer to operator instructions, TM 9-2320-279-10, TM 9-2320-354-10, and TM 9-2320-355-10.

1-11. EQUIPMENT CHARACTERISTICS, CAPABILITIES, AND FEATURES. Refer to TM 9-2320-279-10 for equipment characteristics, capabilities, and features.

1-12. LOCATION AND DESCRIPTION OF COMPONENTS. Refer to TM 9-2320-279-10 for location and description of components.

1-13. DIFFERENCES BETWEEN MODELS. Refer to TM 9-2320-279-20 for major differences between models.

1-14. SAFETY, CARE, AND HANDLING.

a. Significant Hazards and Safety Recommendations. Significant hazards and safety recommendations are listed in Table 1-2.

Table 1-2. Significant Hazards and Safety Recommendations

Hazard	Safety Recommendation or Precaution	Operating Condition ¹
Low air pressure for brakes.	Do not drive vehicle while low air pressure warning buzzer is sounding or red light is on.	Abnormal
Vehicle instability with crane use.	Ensure that outriggers are down on firm ground, side slope does not exceed five degrees, and crane is not overloaded.	Abnormal
Fire with M978 tanker.	No smoking, flames, or sparks within 50 feet (15 m). Disconnect batteries for all electrical work.	Normal
Fuel spills with M978 tanker.	Test tank automatic shutoff before bottom loading per procedure in instructions. Do not bypass dead-man controls.	Abnormal
Connecting towing devices.	Do not go between vehicles until vehicles are stopped and brakes are set.	Normal
Refueling vehicle.	Shut off engine and no smoking when filling tank.	Normal
¹ Category of hazards as to whether or not they maybe expected under normal or abnormal operating conditions.		

b. Cranes. Material handling cranes for models M977, M983, M984, M984E1, M985, and M985E1 all have overload shutdown and/or tilt warning (unstable) systems.

(1) On M983, M984, and M985E1 models a yellow caution light and an audible warning signal alert the operator when an unstable crane condition occurs.

(2) On all models an overload shutdown system prevents overloading the crane. The system will shut down the crane to prevent hoisting, swinging, or boom extension when an overload condition exists. Load lowering and boom retraction functions will not be affected.

Features and Technical Data (Cont)

1-14. SAFETY, CARE, AND HANDLING (CONT).

c. Crane Operating Instruction Plate Locations:

(1) The crane operating instruction plates are located on the heater compartment cover in the cab, and at each of the fixed operating stations.

(2) The outrigger leg signs are located on each of the outrigger cylinders.

(3) The load capacity signs are located at the main and auxiliary control panels.

Section III. PRINCIPLES OF OPERATION.

1-15. PRINCIPLES OF OPERATION. Refer to TM 9-2320-279-20.

CHAPTER 2 MAINTENANCE INSTRUCTIONS

Contents	Para	Page
General	2-1	2-1
Common Tools and Equipment	2-2	2-1
Special Tools	2-3	2-1
Test Equipment	2-4	2-1
Repair Parts	2-5	2-2
Troubleshooting Introduction	2-6	2-2
Troubleshooting Instructions	2-7	2-2
General Maintenance Instructions	2-8	2-137
Lubrication Instructions	2-9	2-139
Preparation for Storage and Shipment	2-10	2-140
Pre-Embarkation Inspection	2-11	2-140

Section I. INTRODUCTION

2-1. GENERAL. This chapter provides information on tools, general maintenance, and troubleshooting at direct support and general support maintenance levels for M977 series vehicles. Preparation for storage and pre-embarkation inspection are also covered.

Section II. REPAIR PARTS, SPECIAL TOOLS, AND TEST EQUIPMENT

Parts, Tools, and Test Equipment

2-2. COMMON TOOLS AND EQUIPMENT. There are common tools and general mechanics tool sets required for maintenance of the vehicle. For authorized common tools and equipment, refer to the Modified Table of Organization and Equipment (MTOE) applicable to your unit.

2-3. SPECIAL TOOLS. Special tools for direct support and general support maintenance are listed in the Repair Parts and Special Tools List (RPSTL) in TM 9-2320-279-34P which is your authority for requisitioning.

2-4. TEST EQUIPMENT. The M977 series vehicles are equipped with a diagnostic connector for Simplified Test Equipment/Internal Combustion Engine (STE/ICE). The STE/ICE connector (fig. 2-1) is located on passenger side of the cab. Refer to TM 9-2320-279-20 for STE/ICE tests.

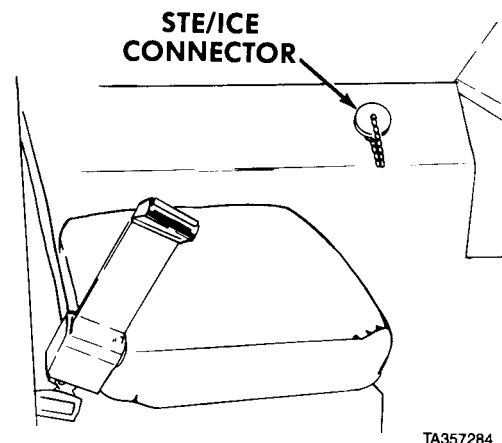

Figure 2-1. STE/ICE Connector.

Parts, Tools, and Test Equipment (Cont)

2-5. REPAIR PARTS. Repair parts authorized for use at the direct support and general support maintenance level are listed and illustrated in Repair Parts and Special Tools Lists (RPSTL).

Section III. TROUBLESHOOTING

2-6. TROUBLESHOOTING INTRODUCTION. This section contains step by step procedures for identifying, locating, isolating, and repairing M977 series vehicle and component malfunctions. Refer to TM 9-2320-354-24&P and TM 9-2320-355-24&P to troubleshoot crane problems on the M984 and M985E1 vehicles.

2-7. TROUBLESHOOTING INSTRUCTIONS. The Troubleshooting Fault Symptom Index (Table 2-1) lists common malfunctions by vehicle system. The Troubleshooting Subject Index (Table 2-2) lists common malfunctions alphabetically. The Troubleshooting Procedures (Table 2-3) lists each malfunction followed by tests, inspections, and corrective actions.

- a. This manual cannot list all malfunctions that may occur, nor all tests, inspections, or corrective actions. If a malfunction is not listed or is not corrected by listed corrective actions, notify the supervisor.
- b. Do the tests and inspections in the order listed, and try to return the vehicle or component to operation after each test, inspection, and corrective action has been performed.
- c. Refer to the figures and foldouts listed below while doing troubleshooting. They will help to isolate and locate troubles and get the vehicle back in service as quickly as possible. Folds are found at the end of this manual.

- Figure 2-2 Main Control Valve (M983)
- Figure 2-3 Outrigger Control Valve (M983)
- Figure 2-4 System Back Pressure (No Load) (M983)
- Figure 2-5 Pressure Tester Setup (M983)
- Figure 2-6 Power Distribution Board Wiring Diagram (M983)
- Figure 2-7 12v Electric Motor Tester Circuit Schematic (M983)
- Figure 2-8 12v Electric Motor Tester Circuit Wiring Diagram (M983)
- Figure 2-9 Arctic Coolant Pump Test (Model A)
- Figure 2-10 Arctic Heater Fault Codes (Model B)
- Foldout 1 Hydraulic Schematics
- Foldout 2 Crane Wiring Diagrams
- Foldout 3 Crane Electrical Schematics

Troubleshooting Index

Table 2-1. Troubleshooting Fault Symptom Index

	Troubleshooting Procedure Page
ENGINE	
1. Engine high idle does not operate	2-10
TRANSMISSION	
1. Transmission oil temperature gage stays over 250°F (121°C)	2-12
2. Transmission noise	2-13
3. Transmission will not shift into gear, slips out of gear or operates erratically	2-15
4. Oil leaking at converter housing	2-16
5. Excessive creep in first and reverse	2-17

Troubleshooting Index (Cont)

Table 2-1. Troubleshooting Fault Symptom Index (Cont)

	Troubleshooting Procedure Page
TRANSMISSION (CONT)	
6. Automatic shifts occur at too high speed	2-18
7. Automatic shifts occur at too low speed or shifts rough	2-19
8. Vehicle moves in neutral	2-20
9. Transmission slips in all forward gears	2-20
10. High stall speed	2-21
11. Low stall speed	2-21
HYDRAULIC SYSTEM	
1. One or more hydraulic circuits inoperative (retriever, crane, winches, tanker pump)	2-22
2. Winch or crane hoist jerks when operated or will not pull load	2-22
3. Retriever or cylinders do not operate smoothly or will not lift load	2-22
4. One or more hydraulic circuits inoperative (fair lead tensioner, steering).	2-22.2
5. Steering is not smooth	2-22.2
STEERING SYSTEM	
1. Wheel turns restricted	2-23
2. Vehicle steers hard in one or both directions (all except M984E1)	2-23
3. Steering is not smooth (seizing, binding) (all except M984E1)	2-24
4. Vehicle steers hard in one or both directions (M984E1)	2-24
5. Steering is not smooth (seizing, binding) (M984E1)	2-24
TANKER SYSTEM	
1. Flow meter does not operate (not registering)	2-25
2. No flow through meter or meter runs too slowly	2-25
SELF-RECOVERY WINCH	
1. Self-recovery winch does not work	2-26
HEAVY-DUTY WINCH (M984)	
1. Winch cable will not payout	2-27
2. Winch will not pull load	2-27
3. Winch makes excessive or unusual noise, or operates slowly or jerks.	2-28
HEAVY-DUTY WINCH (M984E1)	
1. Winch will not operate in remote	2-28
2. Winch will not pull load	2-28.1
3. Winch makes excessive or unusual noise or operates slowly or jerks	2-28.2
4. Winch will not operate in either direction	2-28.3
5. Winch operates in only one direction	2-28.5
6. Winch high speed does not operate or winch does not shift to lower speed under heavy load	2-28.6
7. Fairlead tensioner motor does not operate	2-28.8
MATERIAL HANDLING CRANE (M983)	
1. Crane chatters when nearing maximum travel in any function or when operating with near maximum load	2-32
2. Hoist operates slowly or will not lift load	2-34
3. Hoist will not hold load	2-35
4. Hoist will not lower load	2-36
5. Boom extensions no. 3 and no. 4 will not extend or will not fully extend	2-37
6. Boom extensions no. 3 and no. 4 will not hold load extended or retracted or creeps	2-38
7. Boom extensions no. 3 and no. 4 will not retract or will not fully retract.	2-38

Troubleshooting Index (Cont)

2-7. TROUBLESHOOTING INSTRUCTIONS (CONT).

Table 2-1. Troubleshooting Fault Symptom Index (Cont)

	Troubleshooting Procedure Page
MATERIAL HANDLING CRANE (M983) (CONT)	
8. Boom extension no. 1 or no. 2 will not extend or will not fully extend	2-39
9. Boom extension no. 1 or no. 2 will not hold load extended or retracted, or creeps	2-40
10. Boom extensions no. 1 and no. 2 will not retract or will not fully retract	2-41
11. Boom will not lower or will not lower completely	2-42
12. Boom will not go to maximum height	2-44
13. Boom will not lift load	2-45
14. Boom lowers under load or will not hold load	2-47
15. Crane will not unfold or will not unfold completely	2-47
16. Crane will not fold completely or folds slowly	2-48
17. Crane folds too quickly (falls when folding)	2-50
18. Boom moves slowly	2-50
19. Crane does not rotate	2-54
20. Crane rotates slowly in one direction, but rotates normally in other direction.	2-54
21. Crane creeps clockwise or counterclockwise	2-54
22. Outrigger will not extend or retract	2-55
23. Outrigger will not support load or creeps upward	2-57
24. Crane operating levers not moving in remote control	2-58
25. Crane will not operate in one or more remote control functions	2-61
26. One function rod returns to neutral, but does not respond to controller	2-64
27. Crane operation is not smooth in remote control mode	2-67
28. Control rods do not move completely in or out	2-70
29. Crane will not raise or extend in remote operation, but will lower and retract and swing works in both directions (overload protection circuit malfunction)	2-71
30. No visual or audible tilt alarms	2-76
31. Crane outrigger extended light does not work	2-77
32. Remote controller operating, but crane will not move	2-78
33. Crane starts to move as soon as remote controller is connected and turned on	2-80
MATERIAL HANDLING CRANE (M977, M985, M984E1)	
1. Crane will not operate manually or with remote control	2-81
2. Outrigger operation slow or erratic	2-85
3. Outrigger beam will not extend or retract	2-85
4. Outrigger leg (left or right) will not support load or extend and retract	2-86
5. Mast raises or lowers erratically, slowly, or will not raise and lower	2-87
6. Mast will not hold raised position	2-89
7. Boom operates abnormally, slowly, will not telescope in or out, or raise or lower	2-90
8. Boom operation erratic when telescoping in	2-99
9. Boom will not telescope out	2-100
10. Boom will not telescope in	2-101
11. Boom raises or lowers slowly	2-103
12. Boom will not raise	2-103
13. Boom will not lower (M977, M984E1).	2-106
14. Boom will not hold load	2-107
15. Hoist will not raise load	2-108
16. Hoist will not lower	2-112
17. Hoist operation slow when lowering or raising	2-114
18. Hoist will not hold load	2-115

Troubleshooting Index (Cont)

Table 2-1. Troubleshooting Fault Symptom Index (Cont)

	Troubleshooting Procedure Page
MATERIAL HANDLING CRANE (M977, M985) (CONT)	
19. Hoist lowers load too quickly (load drives hoist motor)	2-115
20. Swing operation slow or erratic in both directions	2-117
21. Swing operation erratic or slow in one direction only	2-119
22. Swing system will not work	2-122
23. Swing motor continues to operate when swing control is in neutral position	2-124
24. Swing motor noisy	2-125
25. Crane controls sticking or control will not move	2-126
26. Crane bounces or jerks or does not operate smoothly when crane controls are operated or returned to neutral	2-126.1
27. Remote controller will not operate crane in one function	2-126.2
RETRIEVAL SYSTEM	
1. Lift cylinder will not lift load	2-126.5
2. Lift cylinder will not extend	2-126.5
3. Tow cylinder will not extend	2-126.5
4. Tow cylinder will not retract	2-126.5
ARCTIC HEATER	
1. Coolant pump fails to operate (indicator light comes on) (Model A)	2-128
2. Arctic heater diagnostic troubleshooting (Direct Level) (Model B)	2-129

Table 2-2. Troubleshooting Subject Index

Subject	Vehicle System	Page
Arctic heater diagnostic troubleshooting (Direct Level)	Arctic Heater (Model B) .	2-129
Automatic shifts occur at too high speed	Transmission	2-18
Automatic shifts occur at too low speed or shifts rough	Transmission	2-19
Boom extension no. 1 or no. 2 will not extend or will not fully extend . . .	Material Handling Crane (M983)	2-39
Boom extension no. 1 or no. 2 will not hold load extended or retracted, or creeps	Material Handling Crane (M983)	2-40
Boom extensions no. 1 and no. 2 will not retract or will not fully retract	Material Handling Crane (M983)	2-41
Boom extensions no. 3 and no. 4 will not extend or will not fully extend	Material Handling Crane (M983)	2-37
Boom extensions no. 3 and no. 4 will not hold load extended or retracted, or creeps	Material Handling Crane (M983)	2-38
Boom extensions no. 3 and no. 4 will not retract or will not fully retract	Material Handling Crane (M983)	2-38

Troubleshooting Index (Cont)

2-7. TROUBLESHOOTING INSTRUCTIONS (CONT).

Table 2-2. Troubleshooting Subject Index (Cont)

Subject	Vehicle System	Page
Boom lowers under load or will not hold load	Material Handling Crane (M983)	2-47
Boom moves slowly	Material Handling Crane (M983)	2-50
Boom operation erratic when telescoping in	Material Handling Crane (M977, M985)	2-93
Boom operates abnormally, slowly, will not telescope in or out, or raise or lower	Material Handling Crane (M977, M985)	2-90
Boom raises or lowers slowly	Material Handling Crane (M977, M985)	2-87
Boom will not telescope out	Material Handling Crane (M977, M985)	2-100
Boom will not go to maximum height	Material Handling Crane (M983)	2-44
Boom will not hold load	Material Handling Crane (M977, M985)	2-107
Boom will not lift load	Material Handling Crane (M983)	2-45
Boom will not lower (M977, M985)	Material Handling Crane (M977, M985)	2-106
Boom will not lower or will not lower completely	Material Handling Crane (M983)	2-42
Boom will not raise	Material Handling Crane (M977, M985)	2-100
Boom will not raise load	Material Handling Crane (M977, M985)	2-100
Boom will not telescope in	Material Handling Crane (M977, M985)	2-101
Cable, winch will not pay out	Heavy Duty Winch	2-27
Control rods do not move complete in or out	Material Handling Crane (M983)	2-69
Coolant pump fails to operate (indicator light comes on)	Arctic Heater Kit (Model A)	2-128
Crane bounces, jerks, or does not operate smoothly	Material Handling Crane (M977, M985)	2-124
Crane chatters when nearing maximum travel in any function or when operating with near maximum load	Material Handling Crane (M983)	2-32
Crane controls sticking	Material Handling Crane (M977, M985)	2-123
Crane controls will not move	Material Handling Crane (M977, M985)	2-123
Crane creeps clockwise or counterclockwise	Material Handling Crane (M983)	2-54
Crane does not rotate	Material Handling Crane (M983)	2-54
Crane folds too quickly (falls when folding)	Material Handling Crane (M983)	2-50

Troubleshooting Index (Cont)

Table 2-2. Troubleshooting Subject Index (Cont)

Subject	Vehicle System	Page
Crane jerks when operated	Hydraulic Material Handling Crane (M977, M985)	2-22 2-124
Crane operating levers not moving in remote control	Material Handling Crane (M983)	2-54
Crane operation is not smooth in remote control mode	Material Handling Crane (M983)	2-69
Crane outrigger extended light does not work	Material Handling Crane (M983)	2-77
Crane overload protection circuit malfunction	Material Handling Crane (M983)	2-73
Crane rotates slowly in one direction, but rotates normally in other direction	Material Handling Crane (M983)	2-54
Crane starts to move as soon as remote controller is connected and turned on	Material Handling Crane (M983)	2-82
Crane will not fold completely or folds slowly	Material Handling Crane (M983)	2-48
Crane will not operate	Material Handling Crane (M977, M985)	2-83
Crane will not operate in one or more remote control functions	Material Handling Crane (M983)	2-61
Crane will not unfold or will not unfold completely	Material Handling Crane (M983)	2-47
Engine high idle does not operate	Engine	2-10
Excessive creep in first and reverse	Transmission	2-17
Flowmeter does not operate (not registering)	Tanker	2-24
High idle does not operate	Engine	2-10
High stall speed	Transmission	2-21
Hoist lowers load too quickly	Material Handling Crane (M977, M985)	2-113
Hoist operates slowly or will not lift load	Material Handling Crane (M983)	2-34
Hoist operation slow when lowering or raising	Material Handling Crane (M977, M985)	2-114
Hoist will not hold load	Material Handling Cranes (M983) (M977, M985)	2-35 2-113
Hoist will not lower load	Material Handling Cranes (M983) (M977, M985)	2-36 2-112
Hydraulic circuits inoperative	Hydraulic	2-22
Hydraulic oil is foamy	Hydraulic	2-22
Lift cylinder will not extend	Retrieval System (M984E1)	2-126.5
Lift cylinder will not lift load	Retrieval System (M984E1)	2-126.5

Troubleshooting Index (Cont)

2-7. TROUBLESHOOTING INSTRUCTIONS (CONT).

Table 2-2. Troubleshooting Subject Index (Cont)

Subject	Vehicle System	Page
Load drives hoist motor	Material Handling Crane (M977, M985) ...	2-113
Low stall speed	Transmission	2-21
Mast raises or lowers erratically or slowly	Material Handling Crane (M977, M985) ...	2-87
Mast will not hold raised position	Material Handling Crane (M977, M985) ...	2-89
Mast will not raise and lower	Material Handling Crane (M977, M985) ...	2-87
Meter runs too slowly	Tanker	2-25
No flow through meter	Tanker	2-25
No visual or audible tilt alarms	Material Handling Crane (M983)	2-76
Oil in reservoir is foamy	Hydraulic	2-22
Oil leaking at converter housing	Transmission	2-16
One or more hydraulic circuits inoperative	Hydraulic	2-22
Outrigger beam will not extend or retract	Material Handling Crane (M977, M985) ...	2-85
Outrigger leg will not extend or retract	Material Handling Crane (M977, M985) ...	2-86
Outrigger leg will not support load	Material Handling Crane (M977, (M985) ..	2-86
Outrigger operation slow or erratic	Material Handling Crane (M977, M985) ...	2-85
Outrigger will not extend or retract	Material Handling Crane (M983)	2-55
Outrigger will not support load or creeps upward	Material Handling Crane (M983)	2-57
Overload protection circuit malfunction	Material Handling Crane (M983)	2-71
Remote control function rod does not respond to controller	Material Handling Crane (M983)	2-64
Remote controller operating, but crane will not move	Material Handling Crane (M983)	2-78
Remote controller will not operate crane	Material Handling Crane (M977, M985) ...	2-126.2
Remote controller will not operate in one function	Material Handling Crane (M977, M985) ...	2-126.2
Rough shifting	Transmission	2-19
Self-recovery winch does not work	Self-Recovery Winch ...	2-26
Steering is not smooth (seizing, binding)	Steering	2-24
Steering wheel turns restricted	Steering	2-23
Swing motor continues to operate when swing control is in neutral position	Material Handling Crane (M977, M985) ...	2-124

Troubleshooting Index (Cont)

Table 2-2. Troubleshooting Subject Index (Cont)

Subject	Vehicle System	Page
Swing motor noisy	Material Handling Crane (M977, M985) . . .	2-125
Swing operation slow or erratic in both directions	Material Handling Crane (M977, M985) . . .	2-117
Swing operation erratic or slow in one direction only	Material Handling Crane (M977, M985) . . .	2-119
Swing system will not work	Material Handling Crane (M977, M985) . . .	2-122
Tilt alarms do not work	Material Handling Crane (M983)	2-76
Tow cylinder will not extend	Retrieval System (M984E1)	2-126.5
Tow cylinder will not retract	Retrieval System (M984E1)	2-126.5
Transmission oil temperature gage stays over 250°F (121 °C)	Transmission.	2-12
Transmission oil leaks at converter housing	Transmission	2-16
Transmission operates erratically.	Transmission	2-15
Transmission shifts at too low speed	Transmission.	2-19
Transmission shifts at too high speed	Transmission.	2-18
Transmission slips in all forward gears	Transmission.	2-20
Transmission slips out of gear.	Transmission	2-15
Transmission will not shift into gear	Transmission	2-15
Transmission shifts roughly	Transmission	2-19
Transmission noisy	Transmission	2-13
Vehicle wanders from side to side	Steering	2-24
Vehicle moves in Neutral	Transmission.	2-20
Vehicle pulls to one side	Steering	2-24
Vehicle steers hard in one or both directions	Steering	2-23
Wheel turns restricted	Steering	2-23
Winch cable will not payout	Heavy-Duty Winch	2-27
Winch does not work	Self-Recovery Winch.	2-26
Winch jerks	Heavy-Duty Winch Hydraulic	2-28 2-22
Winch makes excessive or unusual noise	Heavy-Duty Winch	2-28
Winch operates slowly	Heavy-Duty Winch	2-28
Winch or crane jerks when operated	Hydraulic	2-22
Winch will not pull load	Heavy-Duty Winch	2-27

Troubleshooting Malfunctions

2-7. TROUBLESHOOTING INSTRUCTIONS (CONT.)

Table 2-3. Troubleshooting

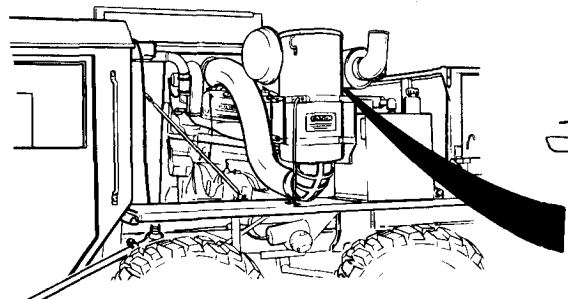
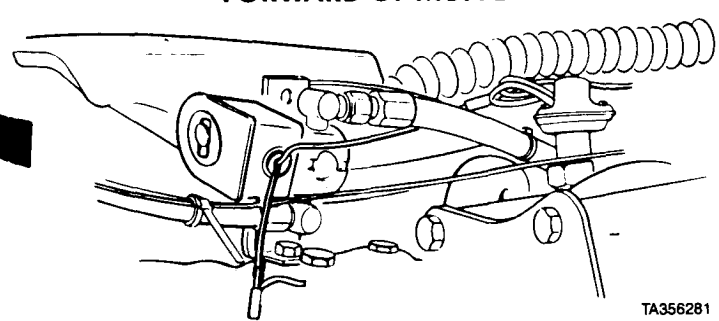
Malfunction	Test or Inspection	Corrective Action
ENGINE		
1. ENGINE HIGH IDLE DOES NOT OPERATE.		
	<p style="text-align: center;">THROTTLE CONTROL SOLENOID LOCATED FORWARD OF MUFFLER</p>  <p style="text-align: right;">TA356281</p>	
NOTE		
<p style="text-align: center;">On M984, winch remote controller switch must be operated instead of LATCH switch.</p>		
<p>Step 1. Check that throttle control solenoid operates when ENGINE, PTO ENGAGE, and LATCH switches are set to ON.</p> <p style="padding-left: 40px;">Replace solenoid if solenoid does not click (TM 9-2815-224-34&P).</p>		
<p>Step 2. Check engine governor adjustment (TM 9-2815-224-34&P).</p> <p style="padding-left: 40px;">Adjust engine governor.</p>		

Troubleshooting Malfunctions (Cont)
 Table 2-3. Troubleshooting (Cont)

Malfunction	Test or Inspection	Corrective Action
<p>TRANSMISSION</p>		
<p>Perform transmission stall test when power package (engine and transmission) is not performing satisfactorily. Purpose of test is to find out if transmission or engine is defective.</p>		
<p><u>WARNING</u></p>		
<p>Apply both parking and service brakes when performing transmission stall test. Block wheels to prevent forward or reverse movement. In the event of brake failure and/or improper blocking of wheels, vehicle can suddenly move forward or backward and may cause personal injury or death.</p>		
<p style="padding-left: 40px;">Chock wheels to prevent forward or reverse movement. Set parking brake (TM 9-2320-279-10). Start engine and set service brakes. Put transfer case in high position, and set transmission to 2 position.</p>		
<p><u>CAUTION</u></p>		
<p>Do not maintain stall condition longer than 30 seconds. Transmission oil can become overheated and damage to transmission may occur. Do not allow temperature to exceed 300 °F (140 °C). Keep close check to prevent engine cooling system from overheating.</p>		
<p>Accelerate engine to full throttle. Write down maximum rpm engine will run (torque converter stall speed). Stall speed should be 2100 rpm (± 150 rpm).</p>		
<p style="padding-left: 40px;">If high engine speed is noted, go to MALFUNCTION 9. If engine speed is low, go to MALFUNCTION 10.</p>		

Troubleshooting Malfunctions (Cont)

2-7. TROUBLESHOOTING INSTRUCTIONS (CONT.)

Table 2-3. Troubleshooting (Cont)

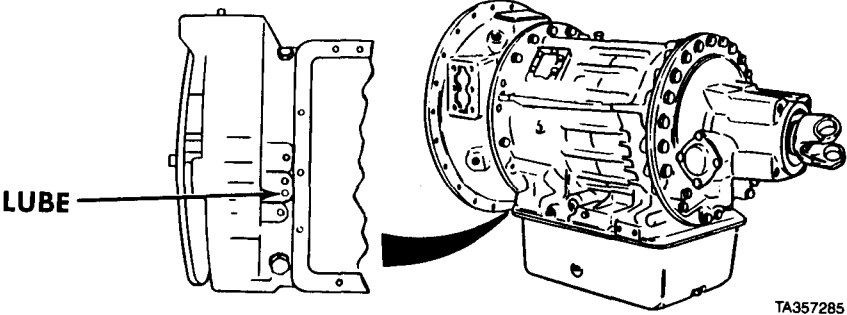
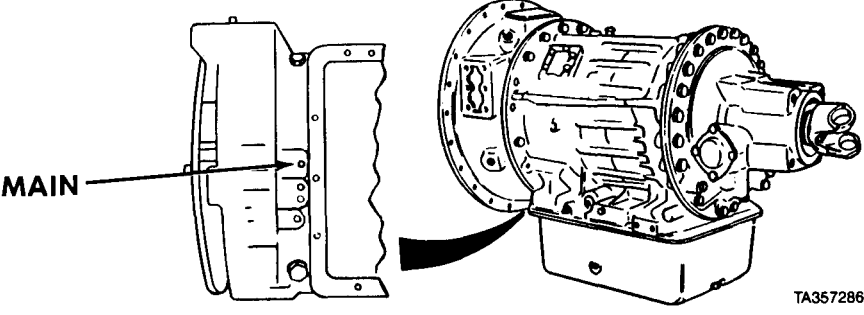
Malfunction	Test or Inspection	Corrective Action
TRANSMISSION (CONT)		
1. TRANSMISSION OIL TEMPERATURE GAGE STAYS OVER 250 °F (121 °C).	 <p>The diagram shows a cross-section of a transmission housing on the left and the transmission assembly on the right. A line labeled 'LUBE' points to a port on the housing. A thick black line representing an oil line connects this port to the transmission assembly.</p>	<p>Step 1. Check for low lubrication oil pressure. Remove oil line from transmission lube port and install tee and 0 to 100 psi (0 to 690 kPa) gage. Start engine and increase speed to approximately 1900 rpm. Check for 25 to 30 psi (172 to 207 kPa) lube system pressure.</p> <p>If pressure is 25 to 30 psi (172 to 207 kPa), disassemble transmission and check for damaged torque converter (para 7-7, 7-8).</p>
	 <p>The diagram shows a cross-section of a transmission housing on the left and the transmission assembly on the right. A line labeled 'MAIN' points to a port on the housing. A thick black line representing an oil line connects this port to the transmission assembly.</p>	<p>Step 2. Check for low main pressure. Remove oil line from main pressure port on transmission and install tee and 0 to 300 psi (0 to 2 070 kPa) gage. Start engine and allow to run at idle speed. With parking brake applied, shift transmission into DRIVE. Check for 105 to 140 psi (725 to 965 kPa) main system pressure.</p> <p>If pressure is 105 to 140 psi (725 to 965 kPa), disassemble transmission and inspect lubrication pressure regulator and converter bypass valve for damage (para 7-9, 7-20).</p>

Troubleshooting Malfunctions (Cont)
Table 2-3. Troubleshooting (Cont)

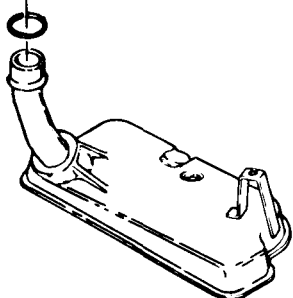
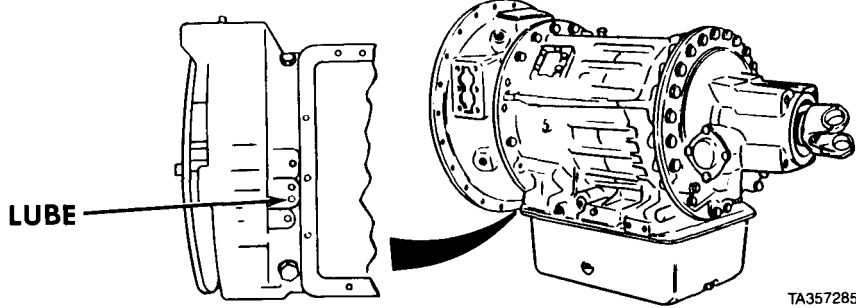
Malfunction	Test or Inspection	Corrective Action
TRANSMISSION (CONT)		
1. TRANSMISSION OIL TEMPERATURE GAGE STAYS OVER 250 °F (121 °C) (CONT).		
 <p style="text-align: right; margin-right: 50px;">TA357287</p>		
<p>Step 3. Check for clogged internal filter element. Remove oil pan (para 7-11). Inspect filter element. If internal filter element is clogged, replace internal filter element (para 7-12).</p>		
<p>Step 4. Check for damaged or missing preformed packing on internal filter pickup tube. If preformed packing is damaged or missing, replace preformed packing (para 7-12). If preformed packing is not damaged or missing, disassemble transmission and inspect oil pump, main pressure regulator valve, and control valve body for loose screws and sticking valves (paras 7-8, 7-9, 7-20).</p>		
2. TRANSMISSION NOISY.		
 <p style="text-align: right; margin-right: 50px;">TA357285</p>		
<p>Step 1. Check for low lubrication oil pressure. Remove and plug lubrication oil line from lube port. Install 0 to 100 psi (0 to 690 kPa) gage at lube port. Start engine and increase speed to approximately 1900 rpm. Check for 25 to 30 psi (172 to 207 kPa) lube system pressure. If pressure is 25 to 30 psi (172 to 207 kPa), disassemble transmission and check torque converter, planetary gear assemblies, and bearings for damage (paras 7-7, 7-8, 7-9, and 7-13).</p>		

Troubleshooting Malfunctions (Cont)

2-7. TROUBLESHOOTING INSTRUCTIONS (CONT).

Table 2-3. Troubleshooting (Cont)

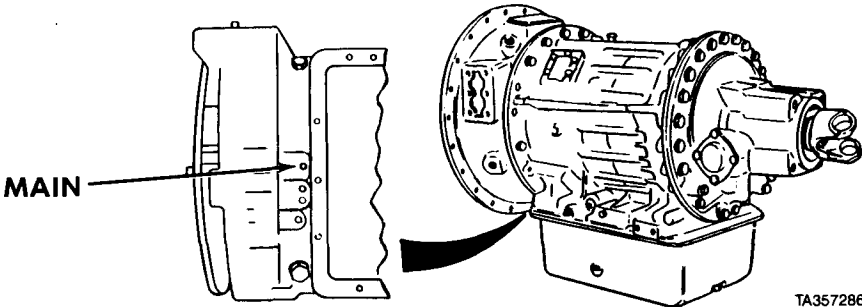
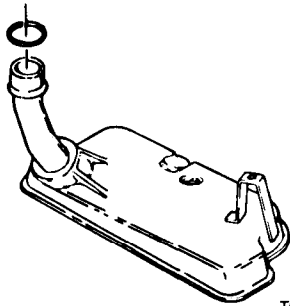
Malfunction	Test or Inspection	Corrective Action
TRANSMISSION (CONT)		
2. TRANSMISSION NOISY (CONT).		
 <p style="text-align: right; margin-right: 50px;">TA357286</p>		
<p>Step 2. Check for low main pressure. Remove line from main pressure port on transmission and install tee and 0 to 300 psi (0 to 2 070 kPa) gage. Start engine and allow to run at idle speed. With parking brake applied, shift transmission into DRIVE. Check for 105 to 140 psi (725 to 965 kPa) main system pressure.</p>		
<p style="padding-left: 40px;">If pressure is 105 to 140 psi (725 to 965 kPa), disassemble transmission and inspect lubrication pressure regulator and converter bypass valve for damage (paras 7-9, 7-20). Inspect all other moving parts for damage from lack of oil.</p>		
 <p style="text-align: right; margin-right: 50px;">TA357287</p>		
<p>Step 3. Check for clogged internal filter element. Remove internal filter element (para 7-12).</p> <p style="padding-left: 40px;">If filter element is clogged, replace filter element (para 7-12).</p> <p style="padding-left: 40px;">If filter element is not clogged, check for damaged or missing preformed packing on pick-up tube. Replace damaged or missing preformed packing (para 7-12).</p> <p style="padding-left: 40px;">If transmission is still noisy, disassemble transmission, inspect oil pump, main pressure regulator valve, converter bypass valve, and lubrication pressure regulator for damage (paras 7-8, 7-9, 7-20). Inspect all other parts for damage from lack of oil.</p>		

Troubleshooting Malfunctions (Cont)
Table 2-3. Troubleshooting (Cont)

Malfunction
Test or Inspection
Corrective Action

TRANSMISSION (CONT)

- 3. TRANSMISSION WILL NOT SHIFT INTO GEAR, SLIPS OUT OF GEAR, OR OPERATES ERRATICALLY.**

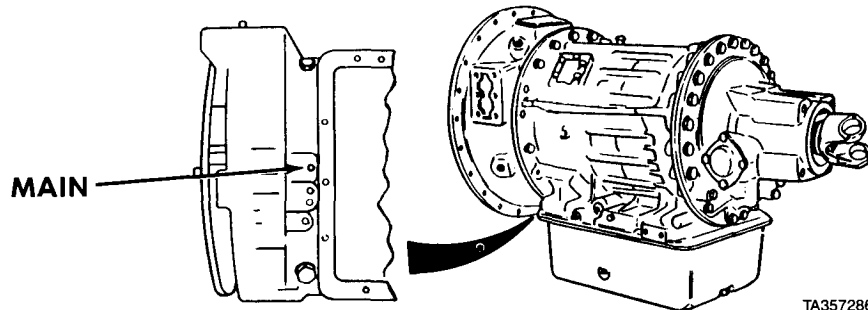

Step 1. Check for low main pressure. Remove line from main pressure port on transmission and install tee and 0 to 300 psi (0 to 2 070 kPa) gage. Start engine and allow to run at idle speed. With parking brake applied, shift transmission into DRIVE. Check for 105 to 140 psi (725 to 965 kPa) main system pressure.

If pressure is 105 to 140 psi (725 to 965 kPa), go to step 4.

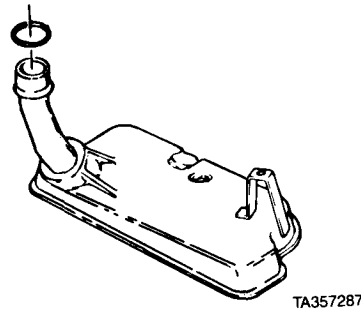

Step 2. Check for clogged internal filter element. Remove oil pan (para 7-11)

If internal filter element is clogged, replace internal filter element (para 7-12).

Step 3. Check for damaged or missing preformed packing on internal filter pickup tube.

If preformed packing is damaged or missing, replace preformed packing and gasket (para 7-12).

If preformed packing is not damaged or missing, disassemble transmission and inspect oil pump, main pressure regulator valve, control valve body for leakage or sticking valves (para 7-8, 7-9, 7-20).

Troubleshooting Malfunctions (Cont)

2-7. TROUBLESHOOTING INSTRUCTIONS (CONT).

Table 2-3. Troubleshooting (Cont)

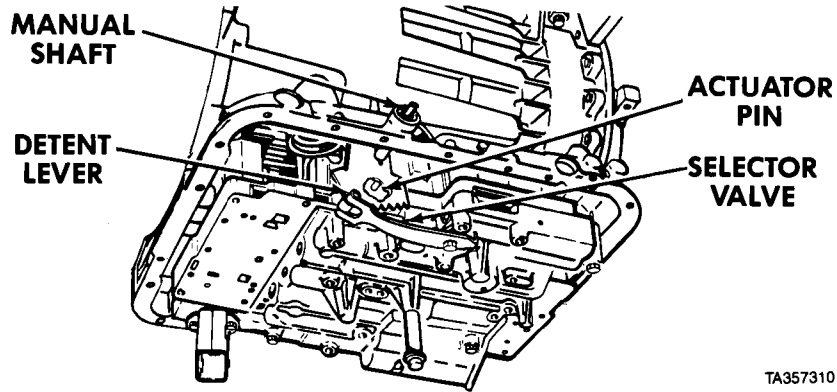
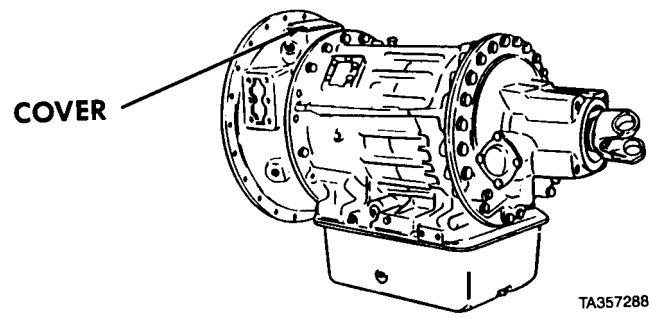
Malfunction	Test or Inspection Corrective Action
TRANSMISSION (CONT)	
<p>3. TRANSMISSION WILL NOT SHIFT INTO GEAR, SLIPS OUT OF GEAR, OR OPERATES ERRATICALLY (CONT).</p>	 <p style="text-align: right;">TA357310</p>
<p>Step 4. Remove oil pan (para 7-11). Manually shift transmission and see if manual shaft and detent lever engage selector valve and that actuator pin is attached to detent lever.</p>	
<p style="padding-left: 40px;">If selector valve does not engage detent lever, repair or replace defective parts (para 7-20).</p>	
<p style="padding-left: 40px;">If selector valve engages detent lever, disassemble transmission and valve body to check for worn clutch packs in transmission, loose valve body screws, and sticking valves in valve body (paras 7-10, 7-15, 7-17, 7-18, 7-19).</p>	
<p>4. OIL LEAKING AT CONVERTER HOUSING.</p>	 <p style="text-align: right;">TA357288</p>

Troubleshooting Malfunctions (Cont)
 Table 2-3. Troubleshooting (Cont)

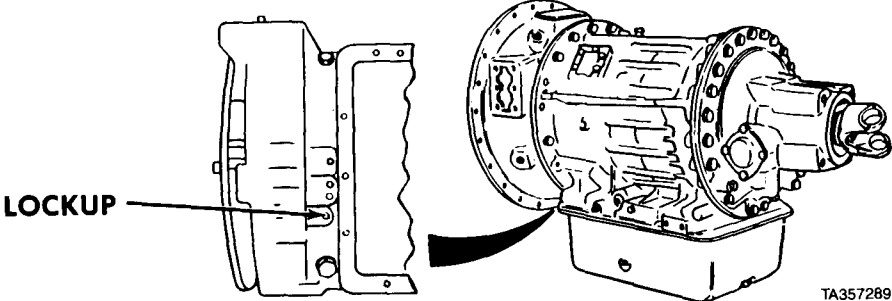
Malfunction	Test or Inspection	Corrective Action
TRANSMISSION (CONT)		
4. OIL LEAKING AT CONVERTER HOUSING (CONT).		
Step 1. Remove cover from top of converter housing. Check for signs of oil.		
If engine oil is inside housing, replace rear engine crankshaft oil seal (TM 9-2320-279-34&P).		
If transmission oil is inside housing, inspect inner converter housing mounting screws, converter pump to converter housing seal ring, converter housing gasket, torque converter cover seal ring, oil pump seal, pitot attachment screws, pump hub seal rings and converter pump hub (para 7-9).		
5. EXCESSIVE CREEP IN FIRST AND REVERSE.		
Step 1. Check for too high engine idle speed.		
If idle speed is more than 750 rpm, adjust engine idle speed (TM 9-2320-279-34&P).		
 <p style="text-align: right; font-size: small;">TA357289</p>		
Step 2. Check for lock up pressure at idle speed. Remove pressure switch at transmission lock up port and install 0 to 300 psi (0 to 2 070 kPa) gage. Start engine and allow to idle with parking brake applied. Shift transmission into DRIVE. Check for 0 psi (0 kPa) lockup pressure. There should be no lockup pressure.		
If there is no lockup pressure, disassemble transmission and check for warped clutch plates, stuck (applied) clutch pack pistons or a damaged torque converter to turbine support bearing (paras 7-7, 7-15, 7-17, 7-18, 7-19).		
If there is any lockup pressure, inspect lockup clutch valve for sticking pistons (para 7-22).		

Troubleshooting Malfunctions (Cont)

2-7. TROUBLESHOOTING INSTRUCTIONS (CONT.)

Table 2-3. Troubleshooting (Cont)

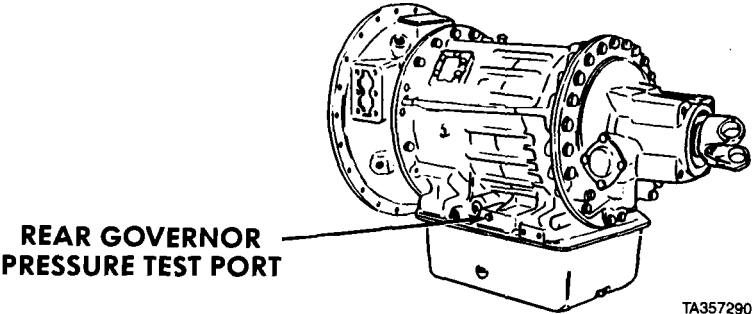
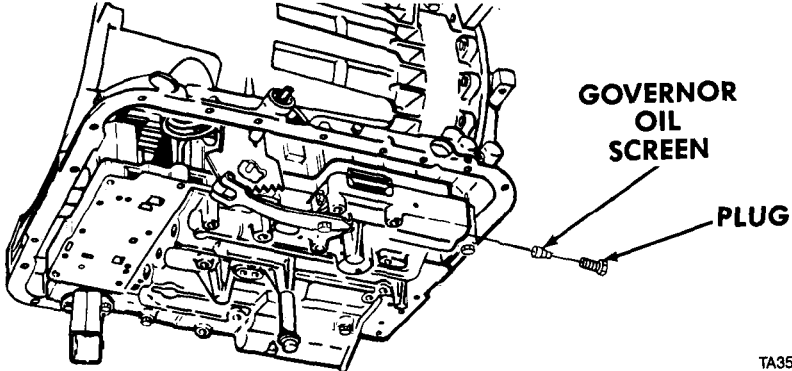
Malfunction	Test or Inspection	Corrective Action
TRANSMISSION (CONT)		
6. AUTOMATIC SHIFTS OCUR AT TOO HIGH A SPEED.		
 <p style="text-align: right; margin-right: 50px;">TA357290</p>		
<p>Step 1. Check rear governor pressure. Remove plug from rear governor test port. Install a 0 to 200 psi (0 to 1 380 kPa) gage at rear governor test port. Start engine and shift transmission into DRIVE. Release parking brake and drive vehicle until engine tachometer reads approximately 1650 rpm. Check for 83 to 91 psi (573 to 628 kPa) rear governor pressure.</p> <p style="padding-left: 40px;">If pressure is 83 to 91 psi (573 to 628 kPa), repair valve body (para 7-23).</p>		
 <p style="text-align: right; margin-right: 50px;">TA357308</p>		
<p>Step 2. Check for clogged governor oil filter screen. Remove oil pan (para 7-11). Remove plug and oil filter screen (para 7-20).</p> <p style="padding-left: 40px;">If oil filter screen is clogged or damaged, clean or replace oil filter screen as required (para 7-20).</p> <p style="padding-left: 40px;">If oil filter screen is not clogged or damaged, go to Malfunction 3, Steps 1 through 3.</p>		

Troubleshooting Malfunctions (Cont)
 Table 2-3. Troubleshooting (Cont)

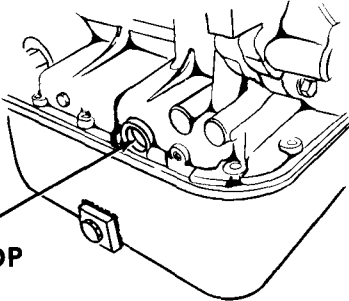
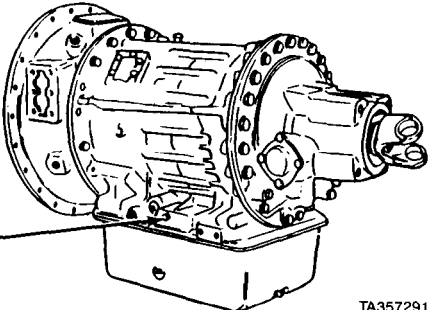
Malfunction	Test or Inspection	Corrective Action
TRANSMISSION (CONT)		
7. AUTOMATIC SHIFTS OCCUR AT TOO LOW A SPEED OR SHIFTS ROUGH.		
<p>Step 1. Check for defective modulator valve. Remove modulator valve from transmission (para 7-21). Apply 70 psi (483 kPa) air pressure at modulator valve hose fitting. Check that modulator valve plunger moves as air is applied. Modulator valve must not leak air when operated.</p>		
<p>If modulator valve does not operate properly, or is damaged, replace modulator valve (para 7-21).</p>		
 <p style="text-align: right; margin-right: 50px;">TA357292</p>		
<p>Step 2. Check for defective control valve. Remove modulator valve (para 7-21). Check valve stop in transmission for free movement in. Check that spring pushes valve stop out when released and is not damaged.</p>		
<p>If valve stop does not move freely or spring is damaged or does not push valve stop out, repair control valve (para 7-20).</p>		
 <p style="text-align: right; margin-right: 50px;">TA357291</p>		
<p>Step 3. Check for high rear governor pressure. Remove plug from rear governor test port. Install a 0 to 200 psi (0 to 1380 kPa) gage at rear governor test port. Start engine and shift transmission into DRIVE. Release parking brake and drive vehicle until engine tachometer reads approximately 1650 rpm. Check for 83 to 91 psi (573 to 628 kPa) rear governor pressure.</p>		
<p>If pressure is over 91 psi (628 kPa) replace governor valve (para 7-23).</p>		
<p>If pressure is 83 to 91 psi (573 to 628 kPa) repair control valve body (para 7-20).</p>		

Troubleshooting Malfunctions (Cont)

2-7. TROUBLESHOOTING INSTRUCTIONS (CONT)

Table 2-3. Troubleshooting (Cont)

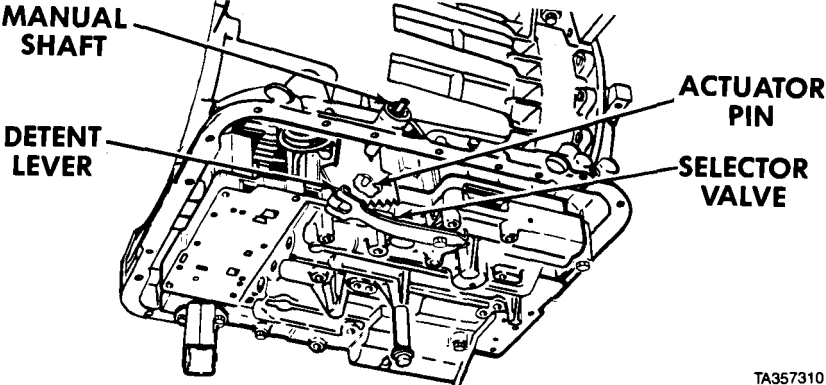
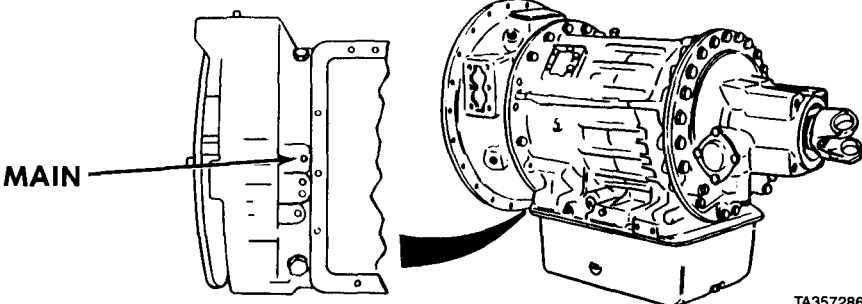
Malfunction	Test or Inspection	Corrective Action
TRANSMISSION (CONT)		
8. VEHICLE MOVES IN NEUTRAL.	 <p style="text-align: right;">TA357310</p>	<p>Step 1. Remove oil pan (para 7-11). Manually shift transmission and see if the manual shaft and detent lever are engaging with selector valve and that actuator pin is attached to detent lever.</p> <p>If selector valve does not engage replace defective parts (para 7-20).</p> <p>If selector valve engages, disassemble transmission and valve body to check for applied clutch packs or leaking or sticking valves in valve body (paras 7-15, 7-16, 7-17, 7-18, 7-19, 7-20).</p>
9. TRANSMISSION SLIPS IN ALL FORWARD GEARS.	 <p style="text-align: right;">TA357286</p>	<p>Step 1. Check for low main pressure. Remove line from main pressure port on transmission and install a tee and a 0 to 300 psi (0 to 2 068 kPa) gage. Start engine and allow to run at idle speed. With parking brake applied, shift transmission into DRIVE. Check for 105 to 140 psi (725 to 965 kPa) main system pressure.</p> <p>If pressure is 105 to 140 psi (725 to 965 kPa), rebuild forward clutch (para 7-15).</p> <p>If pressure is less than 105 to 140 psi (725 to 965 kPa), go to Malfunction 3, steps 1 through 3.</p>

Troubleshooting Malfunctions (Cont)

Table 2-3. Troubleshooting (Cont)

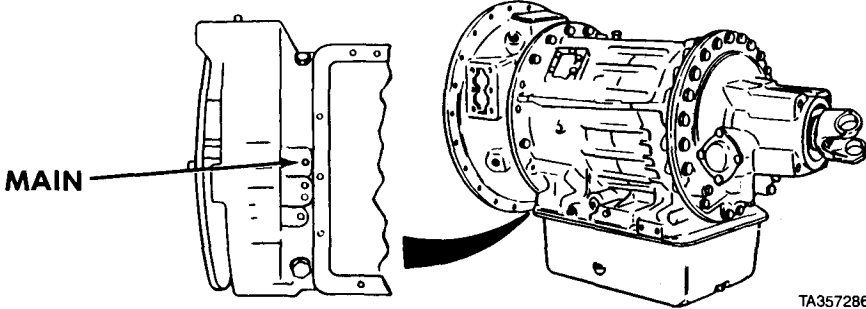
Malfunction	Test or Inspection	Corrective Action
TRANSMISSION (CONT)		
10. HIGH STALL SPEED.	 <p style="text-align: right; margin-right: 50px;">TA357286</p>	<p>Step 1. Check for low main pressure. Remove line from main pressure port. Install tee and 0 to 300 psi (0 to 2 070 kPa) gage. Start engine and allow to run at idle speed. With parking brake applied, shift transmission into DRIVE and accelerate engine to approximately 1200 rpm. Check for 140 to 175 psi (965 to 1 206 kPa) main system pressure.</p> <p style="padding-left: 40px;">If pressure is 140 to 175 psi (965 to 1 206 kPa), disassemble transmission and inspect forward and first clutches for damage (para 7-15, 7-16).</p> <p style="padding-left: 40px;">If pressure is not 140 to 175 psi (965 to 1 206 kPa), go to Malfunction 3, steps 1 through 3.</p>
11. LOW STALL SPEED.	NOTE	<p style="padding-left: 40px;">Do step 1, then run stall check. If problem remains, go to step 2.</p> <p>Step 1. Go to TM 9-2815-224-34&P, ENGINE troubleshooting, ENGINE FAILS TO DELIVER FULL POWER.</p> <p>Step 2. Check for damaged torque converter. Disassemble torque converter stator, pump, and housing (paras 7-7, 7-8, and 7-9).</p> <p style="padding-left: 40px;">Replace damaged torque converter parts (paras 7-7, 7-8, and 7-9).</p>

Troubleshooting Malfunctions (Cont)

2-7. TROUBLESHOOTING INSTRUCTIONS (CONT).

Table 2-3. Troubleshooting (Cont)

Malfunction	Test or Inspection	Corrective Action
-------------	--------------------	-------------------

HYDRAULIC SYSTEM

1. ONE OR MORE HYDRAULIC CIRCUITS INOPERATIVE (RETRIEVER, CRANE, WINCHES, TANKER PUMP).
2. WINCH OR CRANE JERKS WHEN OPERATED OR WILL NOT PULL LOAD.
3. RETRIEVER OR CRANE CYLINDERS DO NOT OPERATE SMOOTHLY OR WILL NOT LIFT LOAD.

NOTE

Before performing hydraulic tests, the hydraulic oil reservoir must be at least warm to the touch.

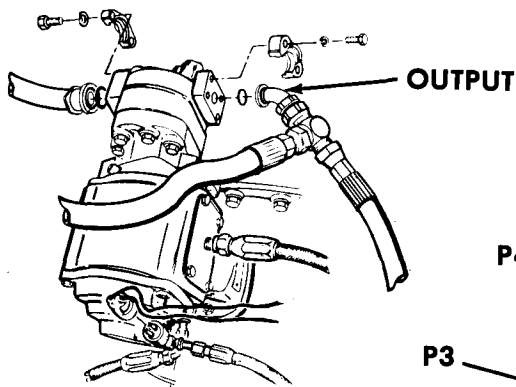
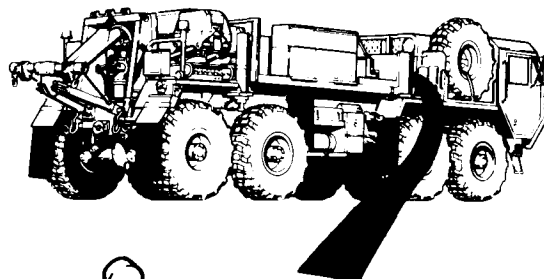
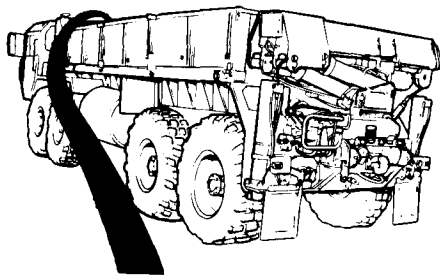

ALL MODELS (EXCEPT M984E1)

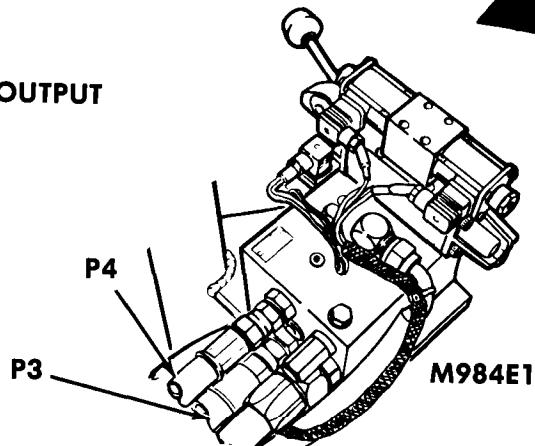

TA476995

Step 1. Check for defective hydraulic PTO pump. Set up hydraulic flowtester on PTO pump output line. For M984E1 check output at both ports P3 and P4. Start engine, engage PTO, set high idle (TM 9-2320-279-10).

Troubleshooting Malfunctions (Cont)
 Table 2-3. Troubleshooting (Cont)

Malfunction	Test or Inspection	Corrective Action
-------------	--------------------	-------------------

HYDRAULIC SYSTEM (CONT)

3. RETRIEVER OR CRANE CYLINDERS DO NOT OPERATE SMOOTHLY OR WILL NOT LIFT LOAD (CONT).

Step 1 (cont). If pump output is less than what is on Fig. 2-3 for the particular model, repair the pump (para 19-3) (para 19-4 for M984E1).

If pump output is correct, go to specific troubleshooting.

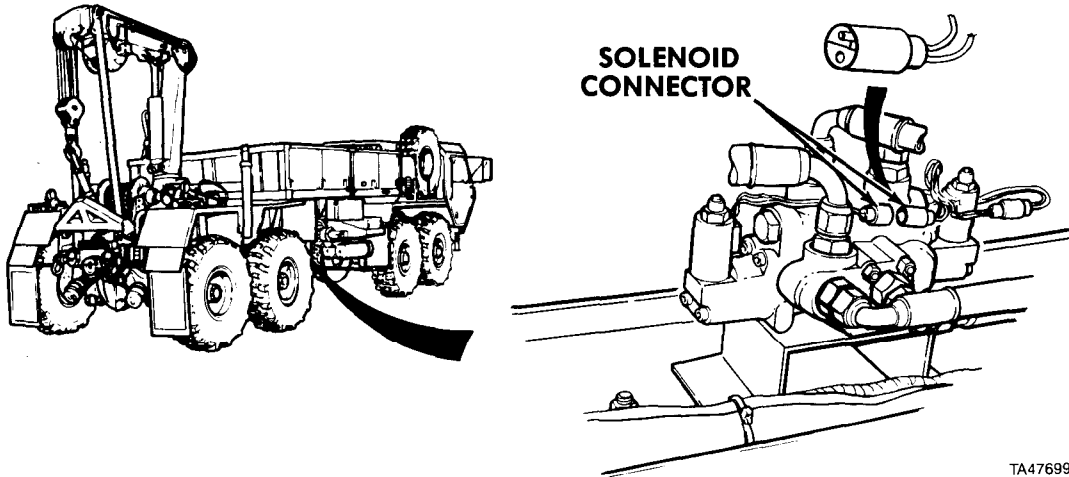

NOTE

M984 only. Disconnect front and rear solenoid connectors from Heavy-Duty winch solenoid valve. Start engine, engage PTO, operate winch remote control to obtain high idle.

PTO PUMP RATINGS

Vehicle Models	Pump Flow (GPM)	Pump Pressure (PSI)	Engine RPM
M977, M983 M985, M985E1	10 GPM (38 liters/min) (Minimum)	3000 psi (20 685 kPa)	1500 rpm
M978	17 GPM (64 liters/min) (Minimum)	3000 psi (20 685 kPa)	1500 rpm
M984 (see note)	20 GPM (76 liters/min) (Minimum)	3000 psi (20 685 kPa)	1800 rpm
M984E1	"P3" 10 GPM (38 liters/min) (Minimum)	3000 psi (20 685 kPa)	1500 rpm
	"P4" 10 GPM (38 liters/min) (Minimum)	3000 psi (20 685 kPa)	1500 rpm

Figure 2-3. PTO Pump Ratings.

Troubleshooting Malfunctions (Cont)

2-7. TROUBLESHOOTING INSTRUCTIONS (CONT).

Table 2-3. Troubleshooting (Cont)

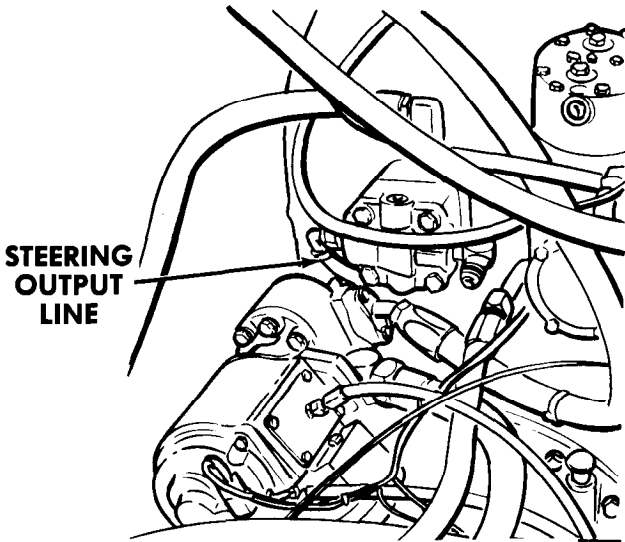
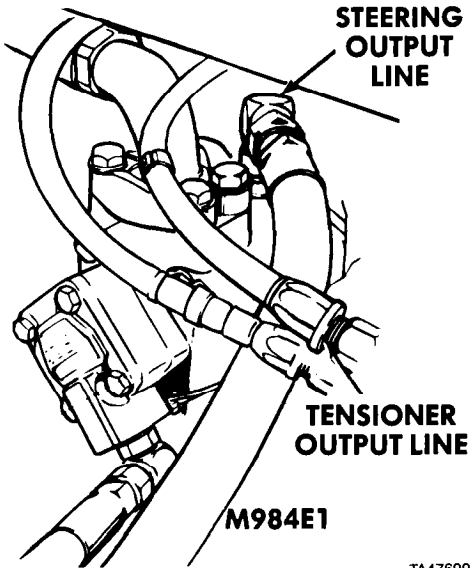
Malfunction	Test or Inspection	Corrective Action
HYDRAULIC SYSTEM (CONT)		
4. ONE OR MORE HYDRAULIC CIRCUITS INOPERATIVE (FAIRLEAD TENSIONER, STEERING).		
5. STEERING IS NOT SMOOTH.		
	NOTE	
		<ul style="list-style-type: none"> • If steering is not working properly, do step 1. If fairlead tensioner motor is not working properly, do step 2. • Before performing hydraulic tests, the hydraulic oil reservoir must be at least warm to the touch.
	 <p>Diagram showing the steering pump output line for all models except M984E1. The line is labeled 'STEERING OUTPUT LINE'.</p>	 <p>Diagram showing the tensioner pump output line for model M984E1. The line is labeled 'TENSIONER OUTPUT LINE'. The model number 'M984E1' is also indicated.</p>
	ALL MODELS (EXCEPT M984E1)	TA476997
	<p>Step 1. Check for defective steering pump. Set up hydraulic flowtester on steering pump output line. Start engine, engage PTO, engine at low idle (TM 9-2320-279-10).</p>	<p>Increase pressure to 1750 psi (12 066 kPa) if output is less than 6 GPM (23 liters/min) up to 1750 psi (12 066 kPa) ± 75 psi (517 kPa), repair steering pump (para 12-7).</p>
		<p>(M984E1). Set pressure at 1750 psi (12 066 kPa). If pump output is less than 6 GPM (23 liters/min) at 1750 psi (12 066 kPa), repair steering pump (para 12-7.1).</p>
		<p>If pump is okay, go to specific troubleshooting.</p>
	<p>Step 2. (M984E1). Check for defective tensioner pump. Set up hydraulic flowtester on tensioner pump output line. Start engine, engage PTO, set high idle (TM 9-2320-279-10).</p>	<p>If pump output is less than 1.7 GPM (6.4 liters/min), at 2250 psi (15 513 kPa), repair tensioner pump (para 12-7.1).</p>
		<p>If pump is okay, go to specific troubleshooting.</p>

Troubleshooting Malfunctions (Cont)
 Table 2-3. Troubleshooting (Cont)

Malfunction	Test or Inspection	Corrective Action
STEERING SYSTEM		
1. WHEEL TURNS RESTRICTED.		
NOTE		
<p>Before performing hydraulic tests, the hydraulic oil reservoir must be at least warm to the touch.</p>		
<p>Step 1. Refer to HYDRAULIC SYSTEM troubleshooting.</p>		
<p>Step 2. Check main steering gear adjustment (para 12-8).</p>		
<p style="padding-left: 40px;">Adjust steering gear (para 12-8).</p>		
<p>Step 3. (M984E1). Set up hydraulic flowtester in line between steering tensioner manifold and primary steering gear. Check oil flow from STR port of steering/tensioner manifold valve. Start engine (TM 9-2320-279-10).</p>		
<p style="padding-left: 40px;">If flow is not 6 to 9 GPM (23 to 34 liters/min), replace flow control valve (para 12-7.2).</p>		
<p style="padding-left: 40px;">If pressure does not relieve at 1750 psi (12 066 kPa) ± 75 psi (517 kPa), replace relief valve.</p>		
<p>Step 4. Remove intergear link (para 12-3). Start engine (TM 9-2320-279-10). Attempt to turn steering wheel lock-to-lock in both directions while having another soldier watch steering gear pitman arms.</p>		
<p style="padding-left: 40px;">If movement of primary or slave steering gears is not smooth, or appears to be binding, repair binding primary or slave steering gear (para 12-5 or 12-6).</p>		
<p>Step 5. If problem remains, check for damaged axle ball sockets.</p>		
<p style="padding-left: 40px;">Replace ball sockets (para 9-13).</p>		

Troubleshooting Malfunctions (Cont)

27. TROUBLESHOOTING INSTRUCTIONS (CONT).

Table 2-3. Troubleshooting (Cont)

Malfunction	Test or Inspection	Corrective Action
STEERING SYSTEM (CONT)		
2. VEHICLE STEERS HARD IN ONE OR BOTH DIRECTIONS (ALL EXCEPT M984E1).		
3. STEERING IS NOT SMOOTH (SEIZING, BINDING) (ALL EXCEPT M984E1).		<p>Step 1. Refer to HYDRAULIC SYSTEM troubleshooting. If problems remains, go to step 2.</p> <p>Step 2. Check wheel alinement (paras 12-10 and 14-7). Aline wheels as required (para 12-10 and 14-7).</p> <p>Step 3. Check steering gear relief valve adjustment (para 12-8). Adjust steering gear (para 12-8).</p> <p>Step 4. Remove steering gear (para 12-5) or slave steering gear (para 12-6). Repair steering gear or slave steering gear (para 12-5 or 12-6).</p>
4. VEHICLE STEERS HARD IN ONE OR BOTH DIRECTIONS (M984E1).		
5. STEERING IS NOT SMOOTH (SEIZING, BINDING) (M984E1).		<p>Step 1. Refer to HYDRAULIC SYSTEM troubleshooting. If problem remains, go to step 2.</p> <p>Step 2. Check wheel alinement (paras 12-10 and 14-7). Aline wheels as required (paras 12-10 and 14-7).</p>

Troubleshooting Malfunctions (Cont)

Table 2-3. Troubleshooting (Cont)

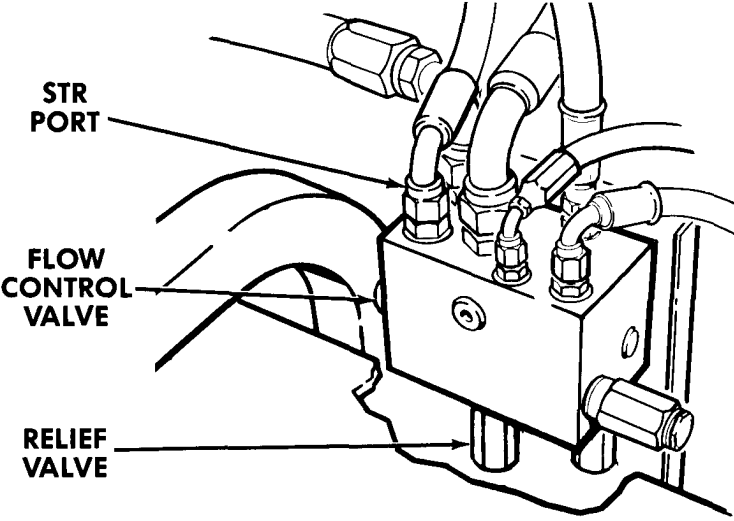
Malfunction	Test or Inspection	Corrective Action
STEERING SYSTEM (CONT)		
5. STEERING IS NOT SMOOTH (SEIZING, BINDING) (M984E1) (CONT).		
 <p>The diagram shows a hydraulic manifold valve assembly. It features a central rectangular block with several ports. On the left, a port is labeled 'STR PORT'. Below it, a valve is labeled 'FLOW CONTROL VALVE'. At the bottom, a valve is labeled 'RELIEF VALVE'. Various hoses and fittings are connected to the top and sides of the manifold.</p>		
TA476999		
Step 3. Check steering gear relief valve adjustment (para 12-7).		
Adjust steering gear (para 12-7).		
Step 4. Check oil flow from steering/tensioner manifold valve. Set up hydraulic flowtester at STR port. Start engine, idle (TM 9-2320-279-10).		
If oil flow is not 6 to 9 GPM (23 to 34 liters/min), replace flow control valve (para 12-7.2).		
If pressure does not relieve at 1750 psi (12 066 kPa) \pm 75 psi (517 kPa), replace relief valve (para 12-7.2).		
Step 5. Remove primary steering gear (para 12-5) and slave steering gear (para 12-6).		
Repair steering gear or slave steering gear (paras 12-5 and 12-6).		

Troubleshooting Malfunctions (Cont)

Table 2-3. Troubleshooting (Cont)

Malfunction	Test or Inspection	Corrective Action
TANKER SYSTEM		
1. FLOWMETER DOES NOT OPERATE (NOT REGISTERING).		
(FLOWMETER REMOVED FROM TANKER FOR CLARITY)		
<p>Step 1. Remove four screws from adjuster cover plate and meter housing.</p> <p>Step 2. Remove adjuster cover plate. Check if gear and shaft are damaged. Replace defective adjuster drive gear or drive shaft (para 22-8).</p> <p>Step 3. Remove flowmeter (para 22-7). Remove front cover (para 22-8). Check for damaged displacement and blocking rotor gears. Replace defective displacement and blocking rotor gears (para 22-8).</p> <p>Step 4. Remove flowmeter (para 22-7). Remove rear cover and bearing plate from meter housing (para 22-8). Check for damaged displacement and blocking rotors. Check for deposits on rotors. Check housing and all parts for damage. If rotors are damaged, replace rotors, replace housing and all damaged parts. Clean deposits from rotors (para 22-8).</p>		
2. NO FLOW THROUGH METER OR METER RUNS TOO SLOWLY.		
<p>Step 1. Remove flowmeter (para 22-7), but do not remove flowmeter register or adjuster. Remove flowmeter front cover (para 22-8). Check for damaged blocking and displacement rotor gears. Replace defective blocking and displacement rotor gears (para 22-8).</p>		

Troubleshooting Malfunctions (Cont)

2-7. TROUBLESHOOTING INSTRUCTIONS (CONT).

Table 2-3. Troubleshooting (Cont)

Malfunction Test or Inspection	Corrective Action
TANKER SYSTEM (CONT)	
2. NO FLOW THROUGH METER OR METER RUNS TOO SLOWLY (CONT).	<p>Step 2. Remove flowmeter (para 22-7). Remove rear cover and bearing plate from meter housing (para 22-8). Check for frozen and damaged blocking and displacement rotors. Check rotors for deposits and corrosion, check meter housing for damage.</p> <p>Clean deposits and corrosion from rotors. If rotors are frozen or damaged, replace rotors. Replace meter housing if damaged. Repair flowmeter (para 22-8).</p>
SELF-RECOVERY WINCH	
1. SELF-RECOVERY WINCH DOES NOT WORK.	<p>Step 1. Go to HYDRAULIC SYSTEM troubleshooting, Malfunction 3.</p> <div style="text-align: center;"> <p style="text-align: right; font-size: small;">TA357293</p> </div> <p>Step 2. Check for defective winch counterbalance valve. Disconnect and plug brake release line at fitting. Install a 0 to 3000 psi (0 to 20 700 kPa) gage on fitting. Start engine and engage PTO. Operate winch IN and winch OUT.</p> <p>If pressure is not 200 psi (1 380 kPa) or above in both directions, replace defective counterbalance valve (para 16-5).</p> <p style="text-align: center;">NOTE</p> <p>Do not disconnect any hydraulic hoses. Check for defective hydraulic motor.</p> <p>Step 3. Remove hose mounting bracket screws. Remove hydraulic motor (para 16-3). Start engine, engage PTO. Operate self-recovery winch IN and OUT.</p> <p>If motor does not operate in both directions, replace self-recovery winch hydraulic motor (para 16-3).</p> <p>Step 4. Check for defective self-recovery winch drum or brake. Remove brake (para 16-7). Turn winch drum.</p> <p>If winch drum turns, replace self-recovery winch brake (para 16-7).</p> <p>If winch drum does not turn, repair self-recovery winch drum (para 16-2).</p>

Troubleshooting Malfunctions (Cont)
Table 2-3. Troubleshooting (Cont)

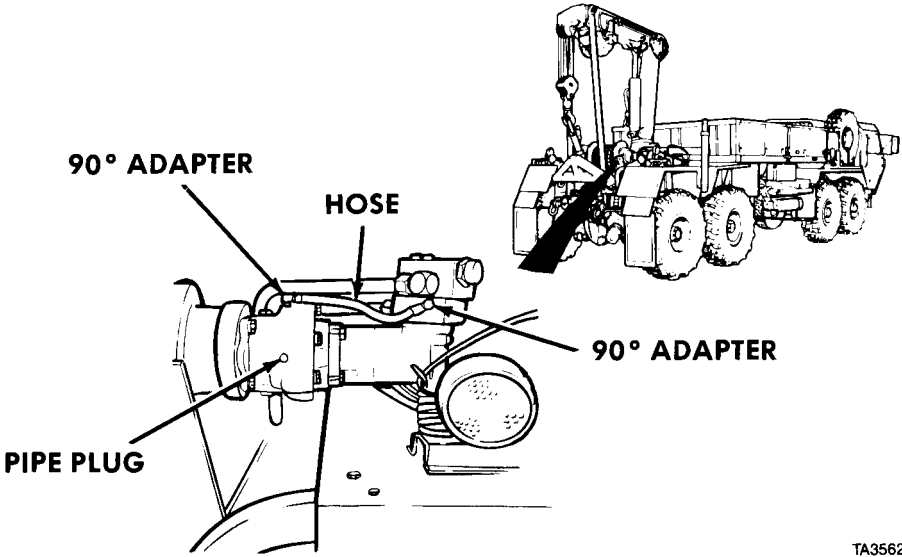
Malfunction	Test or Inspection	Corrective Action
HEAVY-DUTY WINCH (M984)		
1. WINCH CABLE WILL NOT PAY OUT.		
 <p style="text-align: right; font-size: small;">TA356286</p>		
<p>Step 1. Check for plugged winch brake valve pilot ports. Remove hose and adapters. Remove pipe plug.</p>		
<p style="padding-left: 40px;">If brake valve pilot ports are plugged, clean.</p>		
CAUTION		
<p>Heavy-duty winch pressure may be as high as 2660 psi (18 340 kPa). Make sure adequate gage is used or damage to equipment may result.</p>		
<p>Step 2. Check if brake has enough pressure to release brake. Remove pipe plug. Install 0 to 3000 psi (0 to 20 700 kPa) pressure gage. Check for more than 200 psi (1 380 kPa) hydraulic pressure when operating winch.</p>		
<p style="padding-left: 40px;">If pressure is less than 200 psi (1 380 kPa), check hydraulic lines for contamination.</p>		
<p style="padding-left: 40px;">If pressure is more than 200 psi (1 380 kPa), repair winch (para 16-11).</p>		
2. WINCH WILL NOT PULL LOAD.		
<p>Step 1. Go to HEAVY-DUTY WINCH, Symptom 1, WINCH CABLE WILL NOT PAY OUT.</p>		
<p style="padding-left: 40px;">If problem remains, go to step 2.</p>		
<p>Step 2. Check for damaged winch gearing.</p>		
<p style="padding-left: 40px;">Disassemble, clean, inspect, and assemble heavy-duty winch (para 16-11).</p>		

2-7. TROUBLESHOOTING INSTRUCTIONS (CONT.)

Table 2-3. Troubleshooting (Cont)

Malfunction	Test or Inspection	Corrective Action
-------------	--------------------	-------------------

HEAVY-DUTY WINCH (M984) (CONT)

3. WINCH MAKES EXCESSIVE OR UNUSUAL NOISE OR OPERATES SLOWLY OR JERKS.

- Step 1. Check for damaged hydraulic motor front shaft seal.
Remove motor, replace damaged seal (para 16-13.1).
- Step 2. Check for damaged winch brake seals.
Replace damaged winch brake seals (para 16-16).
- Step 3. Check for damaged winch drum seals.
Replace damaged winch drum seals (para 16-12).

HEAVY-DUTY WINCH (M984E1)

1. WINCH WILL NOT OPERATE IN REMOTE.

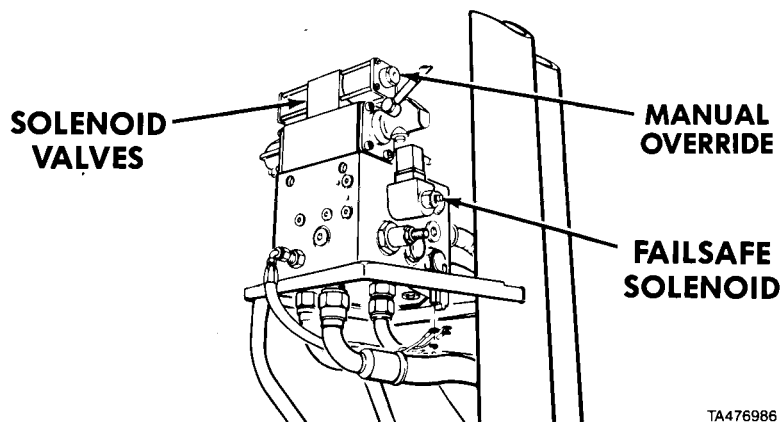

TA476986

NOTE

Before performing hydraulic tests, the hydraulic oil reservoir must be at least warm to the touch.

- Step 1. Manually override solenoid valve (push in). Operate winch (TM 9-2320-279-10).
If winch works, replace solenoid valve (para 20-9).
- Step 2. Manually override failsafe solenoid (push in), operate remote control.
If winch works, replace failsafe solenoid (para 20-9).
- Step 3. Check for plugged pilot ports between solenoid valve and manual valve.
Remove solenoid valve (para 20-9). Clean plugged ports.

Troubleshooting Malfunctions (Cont)

Table 2-3. Troubleshooting (Cont)

Malfunction	Test or Inspection	Corrective Action
HEAVY-DUTY WINCH (M984E1) (CONT)		
2. WINCH WILL NOT PULL LOAD.		
CAUTION		
Do not let cable end run into fairlead tensioner while winching IN or damage to equipment will result.		
NOTE		
All hydraulic tests must be performed with hydraulic oil reservoir at least warm to the touch and at high idle (TM 9-2320-279-10).		
Step 1. Refer to Hydraulic System Troubleshooting.		
<p>The diagram illustrates the hydraulic system components for the winch. On the left is a rectangular relief valve for the winch motor with six ports. In the center is a relief valve for the winch pump, shown in a cutaway view of the winch assembly. On the right is a hydraulic line labeled '904' connected to a winch motor. A truck is shown in the background with a winch on its front. The reference code TA476987 is located at the bottom right of the diagram.</p>		
NOTE		
Pay out approximately 75 ft (25 m) of cable to perform test.		
Step 2. Check for defective winch motor or relief valve. Install flowmeter on hydraulic line 904 on winch motor. While winching IN (TM 9-2320-279-10), operate load valve on flowmeter until relief pressure is obtained.		
If pressure is 2850 psi (19 650 kPa) or more, replace winch motor (para 16-13.1).		
If pressure is less than 2850 psi (19 650 kPa), replace winch motor relief valve (para 20-9).		
If pressure of 2850 psi (19 650 kPa) still cannot be obtained, replace winch pump relief valve (para 20-8).		
3. WINCH MAKES EXCESSIVE OR UNUSUAL NOISE OR OPERATES SLOWLY OR JERKS.		
Step 1. Check for defective winch motor or winch assembly. Remove winch hydraulic motor from winch assembly (para 16-13.1), but do not disconnect hydraulic lines. Operate winch motor (TM 9-2320-279-10).		
If problem is gone, replace winch assembly (TM 9-2320-279-20).		
If problem remains, replace winch motor (para 16-13.1).		

2-7. TROUBLESHOOTING INSTRUCTIONS (CONT).

Table 2-3. Troubleshooting (Cont)

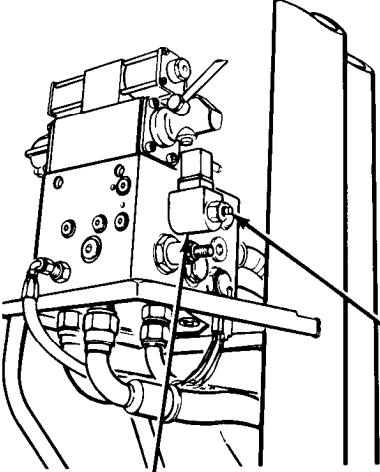
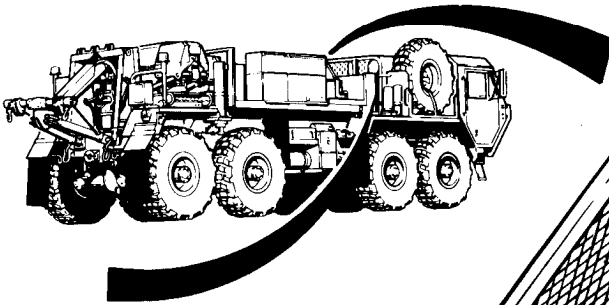
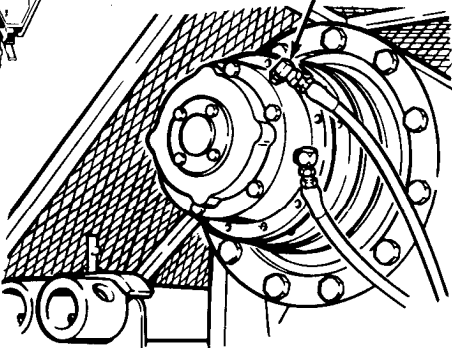
Malfunction Test or Inspection Corrective Action
<p style="text-align: center;">HEAVY-DUTY WINCH (M984E1) (CONT)</p> <p>4. WINCH WILL NOT OPERATE IN EITHER DIRECTION.</p> <p>Step 1. Refer to Hydraulic System Troubleshooting.</p> <div style="display: flex; justify-content: space-around; align-items: center;">    </div> <p style="text-align: center;">FAILSAFE SOLENOID MANUAL OVERRIDE BRAKE RELEASE LINE</p> <p style="text-align: right;">TA476988</p> <p>Step 2. Check for defective failsafe solenoid. Push in and hold manual override button on failsafe solenoid and operate winch (TM 9-2320-279-10). If winch operates, replace failsafe solenoid (para 16-18).</p> <p>Step 3. Check for defective winch counterbalance valve. Install 0-5000 psi (0-34 475 kPa) pressure gauge on brake release line. Check for minimum of 200 psi (1 379 kPa) when operating winch controls (TM 9-2320-279-10). If pressure is less than 200 psi (1 379 kPa), remove, clean, inspect counterbalance valve for damage or clogged ports, replace defective counterbalance valve (para 16-15.1).</p> <p>Step 4. Check for defective winch motor or winch brake. Remove hydraulic motor from winch assembly (para 16-13.1) but do not disconnect hydraulic lines. Operate winch motor (TM 9-2320-279-10). If winch motor does not turn, replace winch motor (para 16-13.1). If winch motor turns, replace winch brake (para 16-17).</p> <p>Step 5. Install hydraulic motor on winch assembly and operate winch (TM 9-2320-279-10). If winch does not operate, replace winch assembly (TM 9-2320-279-20).</p>

Troubleshooting Malfunctions (Cont)
 Table 2-3. Troubleshooting (Cont)

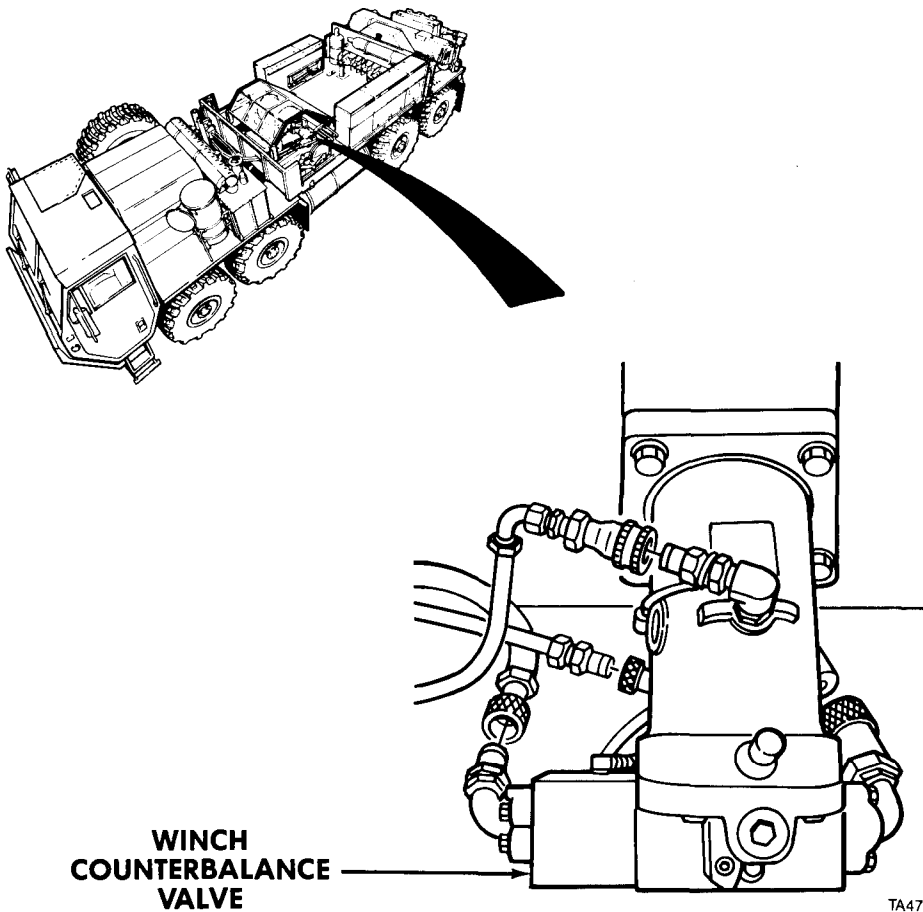
Malfunction	Test or Inspection	Corrective Action
HEAVY-DUTY WINCH (M984E1) (CONT)		
5. WINCH OPERATES IN ONLY ONE DIRECTION.		
 <p>The diagram consists of two parts. The upper part is a perspective view of a heavy-duty truck with a winch mounted on its bed. A thick black arrow points from the winch on the truck towards a detailed technical drawing of the winch counterbalance valve. The valve is a complex hydraulic component with several ports, hoses, and a central handle. A label 'WINCH COUNTERBALANCE VALVE' with a line pointing to the valve is located to the left of the drawing. The drawing is identified by the code 'TA476990' in the bottom right corner.</p>		
<p>Step 1. Check for damaged or clogged counterbalance valve. Remove, clean, inspect counterbalance valve for damage and clogged parts (para 16-15.1). Replace defective counterbalance valve.</p>		

Troubleshooting Malfunctions (Cont)

2-7. TROUBLESHOOTING INSTRUCTIONS (CONT).

Table 2-3. Troubleshooting (Cont)

Malfunction Test or Inspection	Corrective Action
HEAVY-DUTY WINCH (M984E1) (CONT)	
<p>6. WINCH HIGH SPEED DOES NOT OPERATE OR WINCH DOES NOT SHIFT TO LOWER SPEED UNDER HEAVY LOAD.</p>	
NOTE	
<p>All hydraulic tests must be performed with hydraulic oil reservoir at least warm to the touch and at high idle (TM 9-2320-279-10).</p>	
<p>Step 1. Refer to Hydraulic System Troubleshooting. If problem remains go to Step 2.</p>	
<p>The diagram illustrates the hydraulic system components for the winch. It shows a side view of a truck with a winch mounted on the front. A callout provides a detailed view of the winch motor relief valve. Another callout shows the PTO pump relief valve assembly, which includes two hydraulic lines: line 904 (input) and line 903 (output).</p>	
NOTE	
<p>When performing test, winch control valve must be fully engaged, or test readings will be faulty.</p>	
<p>Step 2. Check for defective relief valves or winch motor. Disconnect hydraulic lines 903 and 904 at quick disconnect on winch hydraulic motor. Install flowmeter so hydraulic line 904 flows into meter and hydraulic line 903 flows out. Operate winch IN at manual station. While winching IN (TM 9-2320-279-10) operate load valve on flowmeter until relief pressure is obtained.</p>	

TA476991

Troubleshooting Malfunctions (Cont)
 Table 2-3. Troubleshooting (Cont)

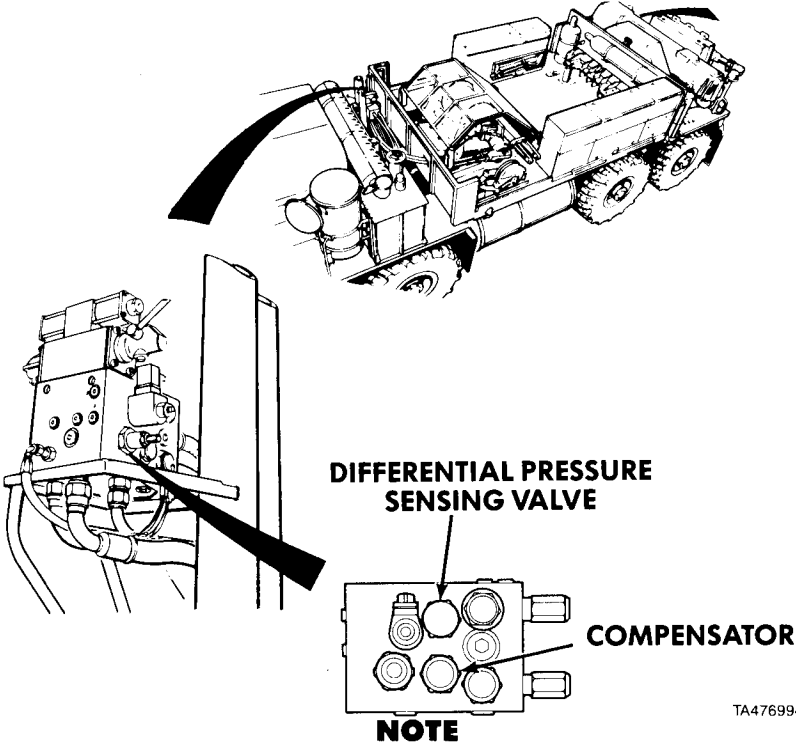
Malfunction Test or Inspection	Corrective Action
HEAVY-DUTY WINCH (M984E1) (CONT)	
6. WINCH HIGH SPEED DOES NOT OPERATE OR WINCH DOES NOT SHIFT TO LOWER SPEED UNDER HEAVY LOAD (CONT).	
Step 2. (cont).	<p>If flow is less than 20 GPM (76 liters/min) at 2850 psi (19 650 kPa), refer to Step 3.</p> <p>If flow is 20 GPM (76 liters/min) or more at 2850 psi (19 650 kPa), replace winch motor (para 16-13.1).</p> <p>If 2850 psi (19 650 kPa) cannot be obtained, replace winch motor relief valve (para 20-8). If problem is not solved, replace PTO pump relief valves (para 20-8).</p>
 <p>NOTE</p> <p>TA476994</p>	
<ul style="list-style-type: none"> • When performing test, the Self-Recovery and Heavy-Duty Winch control valve must be fully engaged, or test results will be faulty. • This is a two-soldier test. <p>Step 3. Check for defective differential pressure sensing valve or compensator. Operate self-recovery winch OUT, while self-recovery winch is paying out cable, operate Heavy-Duty Winch OUT.</p> <p>If self-recovery winch stops while heavy-duty winch operates, replace compensator (para 20-9).</p> <p>If self-recovery winch does not stop while heavy-duty winch operates, replace differential pressure sensing valve (para 20-9).</p>	

2-7. TROUBLESHOOTING INSTRUCTIONS (CONT)

Table 2-3. Troubleshooting (Cont)

Malfunction Test or Inspection	Corrective Action
HEAVY-DUTY WINCH (M984E1) (CONT)	
7. FAIRLEAD TENSIONER MOTOR DOES NOT OPERATE.	
TA476992	
CAUTION	
<p>Fairlead cable adjuster must be loosened before performing test or damage to equipment may result.</p>	
NOTE	
<p>Loosen fairlead cable adjuster (para 16-10.3) and have another soldier pull on winch cable while performing test.</p>	
<p>Step 1. Remove hydraulic pressure line (666) from fairlead tensioner motor and install 0-5000 psi pressure gauge on line end. Operate winch OUT (TM 9-2320-279-10) and read pressure gauge.</p>	
<p style="padding-left: 40px;">If pressure is 2100 psi (14 480 kPa) or more, go to Step 2.</p>	
<p style="padding-left: 40px;">If pressure gauge indicates less than 2100 psi (14 480 kPa), go to Step 3.</p>	
<p>Step 2. Remove fairlead tensioner motor (para 16-18) but do not disconnect hydraulic lines. Operate winch OUT (TM 9-2320-279-10).</p>	
<p style="padding-left: 40px;">If fairlead tensioner motor turns, replace fairlead tensioner (para 16-18).</p>	
<p style="padding-left: 40px;">If fairlead tensioner motor does not turn, replace fairlead tensioner motor (para 16-18).</p>	

Troubleshooting Malfunctions (Cont)
 Table 2-3. Troubleshooting (Cont)

Malfunction	Test or Inspection	Corrective Action
-------------	--------------------	-------------------

HEAVY-DUTY WINCH (M984E1) (CONT)

7. FAIRLEAD TENSIONER MOTOR DOES NOT OPERATE (CONT).

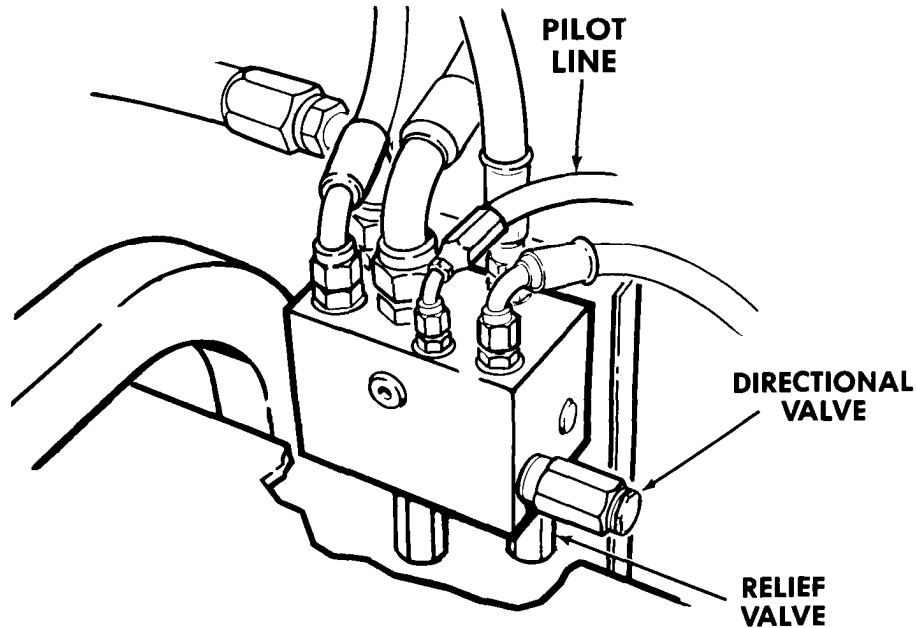

TA476993

- Step 3. Remove pilot line from steering/tensioner manifold and install pressure gage on pilot line. Operate winch OUT (TM 9-2320-279-10).
 If pressure is less than 300 psi (2 070 kPa), go to HYDRAULIC SYSTEM Troubleshooting, Symptom 1.
- Step 4. Check for defective directional control valve or relief valve. Remove, clean, inspect for damage or clogged parts (para 12-7.2).
 Replace defective directional control valve or relief valve (para 12-7.2).

Troubleshooting Malfunctions (Cont)

2-7. TROUBLESHOOTING INSTRUCTIONS (CONT).

Table 2-3. Troubleshooting (Cont)

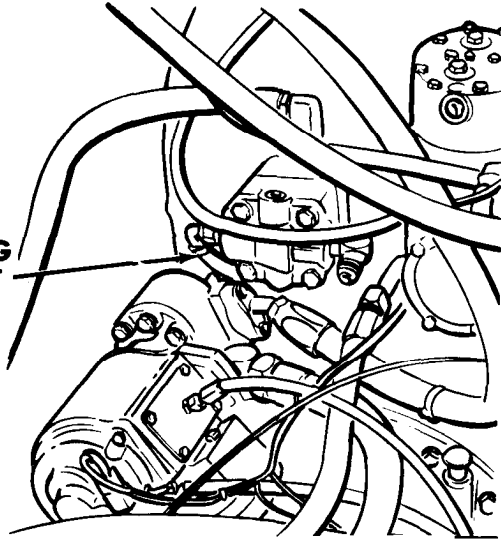
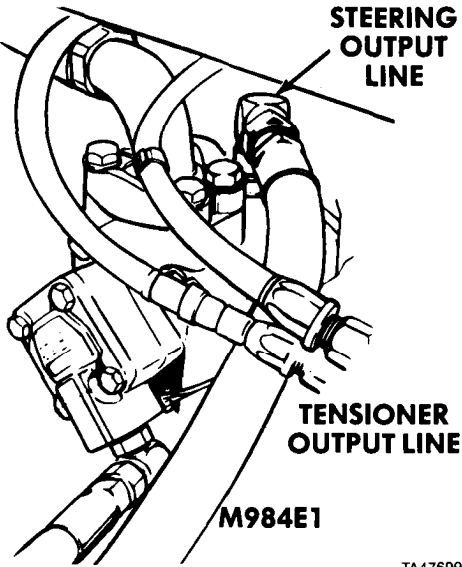
Malfunction	Test or Inspection	Corrective Action
HEAVY-DUTY WINCH (M984E1) (CONT)		
7. FAIRLEAD TENSIONER MOTOR DOES NOT OPERATE (CONT).		
 <p>STEERING OUTPUT LINE</p>	 <p>STEERING OUTPUT LINE</p> <p>TENSIONER OUTPUT LINE</p> <p>M984E1</p>	
		ALL MODELS (EXCEPT M984E1)
<p>Step 5. Check for defective tensioner pump. Set up hydraulic flowtester on tensioner pump output line. Start engine, engage PTO, and set high idle (TM 9-2320-279-10).</p>		
<p>If pump output is less than 1.7 GPM (6 liters/min) at 2250 psi (15 513 kPa), repair tensioner pump (para 12-7.1).</p>		
MATERIAL HANDLING CRANE (M983)		
<u>WARNING</u>		
<p>Always support crane when disconnecting lines from cylinders when crane is not in transport position. Crane may fall, causing injury or death.</p>		
<u>NOTE</u>		
<ul style="list-style-type: none"> • A common cause of crane malfunction is contaminated oil. Seals and packings frequently break down in very hard use, and small pieces of seals and packings can travel through hydraulic lines into control valves, slowing or completely blocking oil flow. • Figures 2-3, 2-4, and 2-5 show each operating system, controlling valves for each operation, control valve parts that affect system operation, and normal operating pressures for the system. • Check out control valves for contamination only after checking out external lines and check valves. • When troubleshooting the material handling crane, refer to FO-1, Hydraulic Schematics, FO-2, Crane Wiring Diagrams, and FO-3, Crane Electrical Schematics. 		

TA476997

Troubleshooting Malfunctions (Cont)
 Table 2-3. Troubleshooting (Cont)

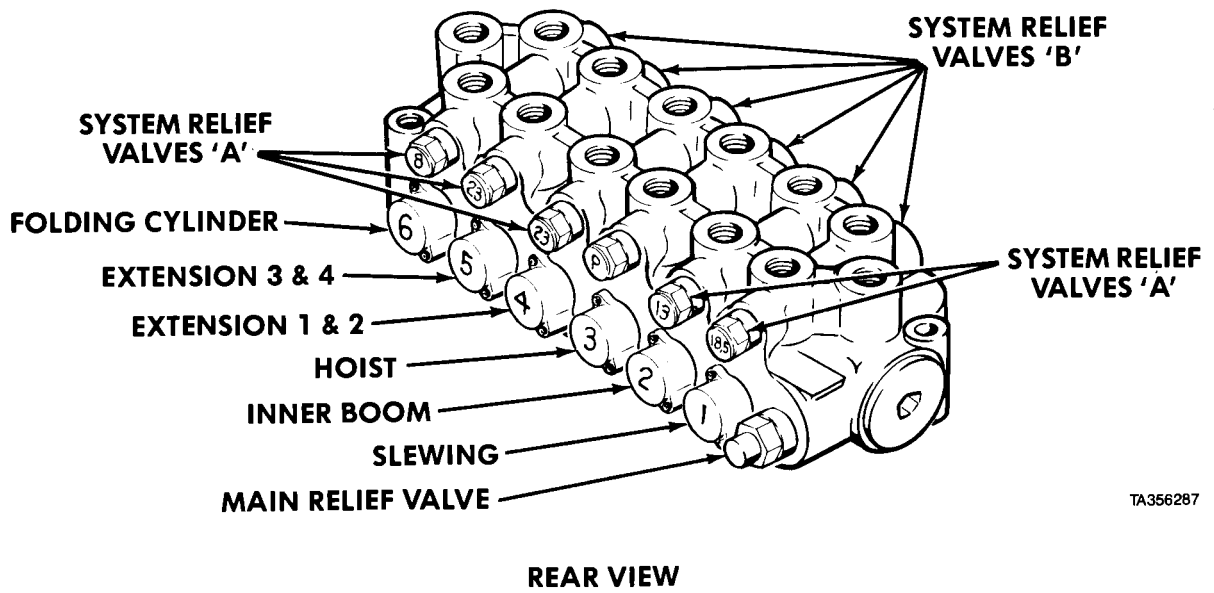

TA356287

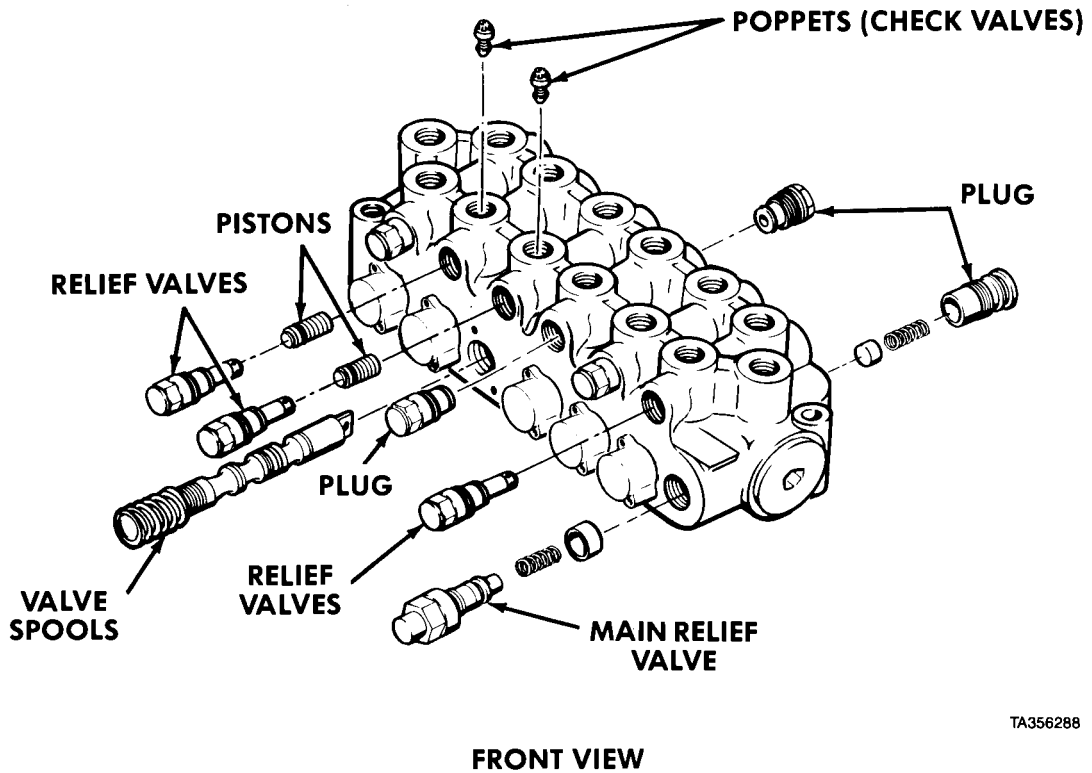

TA356288

Figure 2-2. Main Control Valve (M983).

Troubleshooting Malfunctions (Cont)

2-7. TROUBLESHOOTING INSTRUCTIONS (CONT).

Table 2-3. Troubleshooting (Cont)

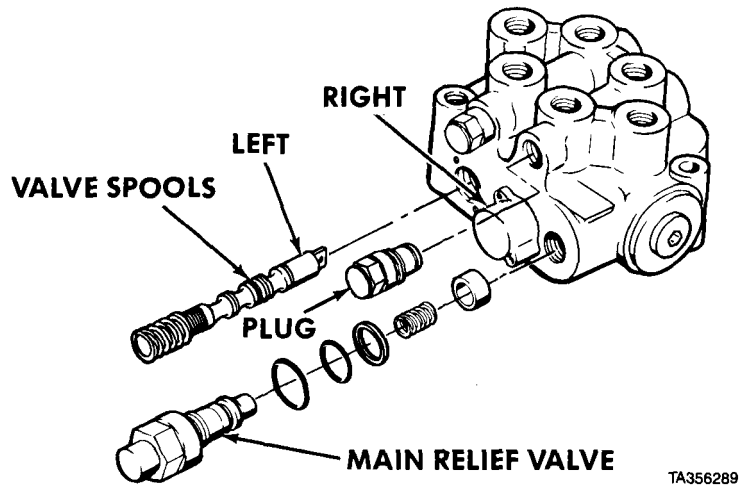

Figure 2-3. Outrigger Control Valve (M983).

Troubleshooting Malfunctions (Cont)

Table 2-3. Troubleshooting (Cont)

System	Low Idle	Relief	High Idle	Relief
Main	73 psi (05 mPa)	N/A	175 psi (1.21 mPa)	N/A
Outrigger-down	175 psi (1.21 mPa)	2395 psi (16.5 mPa)	218-290 psi (1.5-2 mPa)	2685 psi (18.5 mPa)
Outrigger-up	1595 psi (11 mPa)	2395 psi (16.5 mPa)	2830-2900 psi (19.5-20 mPa)	3050 psi (21 mPa)
Unfolding-down	365 psi (2.5 mPa)	1525 psi (10.5 mPa)	1670 psi (11.5 mPa)	2685 psi (18.5 mPa)
Unfolding-up	220 psi (1.5 mPa)	1380 psi (9.5 mPa)	365 psi (2.5 mPa)	2395 psi (16.5 mPa)
Inner Boom-dn	1305 psi (9 mPa)	2685 psi (18.5 mPa)	2175 psi (15 mPa)	2685 psi (18.5 mPa)
Inner Boom-up	580 psi (4 mPa)	2685 psi (18.5 mPa)	1305 psi (9 mPa)	2685 psi (18.5 mPa)
Hoist-down	870 psi (6 mPa)		1595 psi (11 mPa)	
Hoist-up	580 psi (4 mPa)		1305 psi (9 mPa)	
Slewing	1160-1450 psi (8-10 mPa)	2395 psi (16.5 mPa)	2465 psi (17 mPa)	2685 psi (18.5 mPa)
Ext 1-out	435 psi (3 mPa)	2395 psi (16.5 mPa)	1015 psi (7 mPa)	2685 psi (18.5 mPa)
Ext 1-in	1450 psi (10 mPa)		2465 psi (17 mPa)	
Ext 2-out	1305 psi (9 mPa)		1885 psi (13 mPa)	
Ext 2-in	1305 psi (9 mPa)		2465 psi (17 mPa)	
Ext 3-out	1305 psi (9 mPa)		2320 psi (16 mPa)	
Ext 3-in	1525 psi (10.5 mPa)		2320 psi (16 mPa)	
Ext 4-out	1670 psi (11.5 mPa)		2465 psi (17 mPa)	
Ext 4-in	1450 psi (10 mPa)		2320 psi (16 mPa)	

Figure 2-4. System Back Pressure (No Load) (M983).

Troubleshooting Malfunctions (Cont)

2-7. TROUBLESHOOTING INSTRUCTIONS (CONT).

Table 2-3. Troubleshooting (Cont)

Malfunction	Test or Inspection	Corrective Action
MATERIAL HANDLING CRANE (M983) (CONT)		
1. CRANE CHATTERS WHEN NEARING MAXIMUM TRAVEL IN ANY FUNCTION OR WHEN OPERATING WITH NEAR MAXIMUM LOAD.		
	Step 1. Check for bad main relief valve. Listen to main control valve for high-pitched sound while operating crane (TM 9-2320-279-10).	If valve has high pitched sound, replace main relief valve (para 18-41).
	Step 2. Check for worn, broken, chipped, rough-surfaced, or missing boom slide pads.	Replace worn, damaged, or missing pads (paras 18-9, 18-10, and 18-11).
	Step 3. Set up test gage on outrigger control valve (fig. 2-6). Check pressure when moving crane to maximum travel (TM 9-2320-279-10).	If pressure is 2395 to 3050 psi (16.5 to 21 mPa), repair faulty cylinders (Chapter 18, CRANE MAINTENANCE).
		If pressure is below 2395 psi (16.5 mPa), replace main system relief valve (para 18-41).

Troubleshooting Malfunctions (Cont)

Table 2-3. Troubleshooting (Cont)

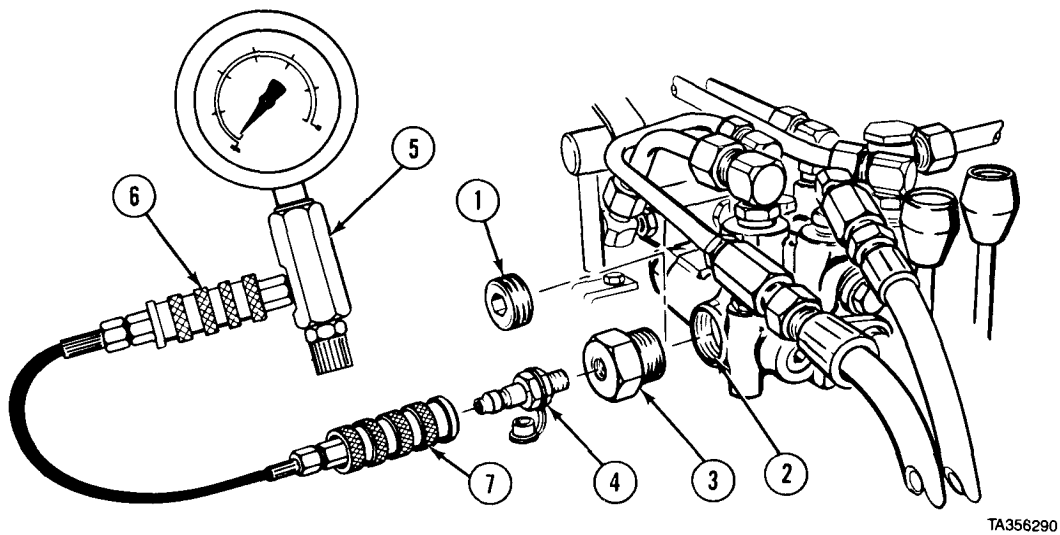

Figure 2-5. Pressure Tester Setup (M983).

Special Tools:

Adapter 3091597

Box, measure 9968709

Gage, pressure 9968792

Equipment Condition:

Rear catwalk mount removed (TM 9-2320-279-20).

a. Installation.

- (1) Remove plug (1) from outtrigger control valve port (2).
- (2) Install adapter (3) in port (2).
- (3) Install nipple (4) in adapter (3).
- (4) Connect gage (5) to adapter (6).
- (5) Connect quick connector (7) to nipple (4).

b. Removal.

- (1) Disconnect connector (7) from nipple (4).
- (2) Disconnect gage (5) from adapter (6).
- (3) Remove nipple (4) from adapter (3).
- (4) Remove adapter (3) from port (2).
- (5) Install plug (1) in outtrigger control valve port (2).

2-7. TROUBLESHOOTING INSTRUCTIONS (CONT).

Table 2-3. Troubleshooting (Cont)

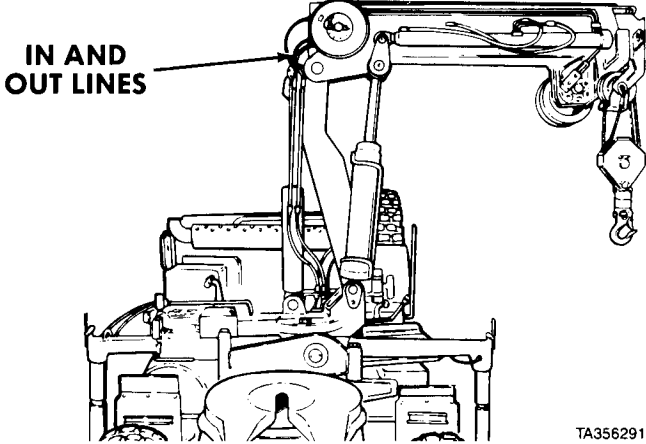
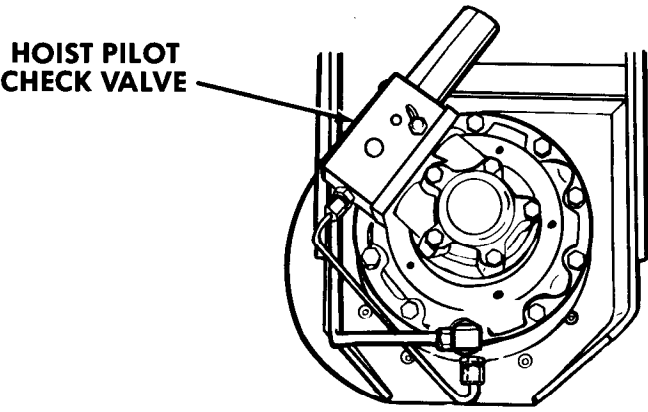
Malfunction	Test or Inspection	Corrective Action
MATERIAL HANDLING CRANE (M983) (CONT)		
2. HOIST OPERATES SLOWLY OR WILL NOT LIFT LOAD.		
 <p style="text-align: right; margin-right: 50px;">TA356291</p>		
<p>Step 1. Set up pressure tester (fig. 2-5). Disconnect hoist IN and hoist OUT lines. Check lines for damage. Connect lines together and check pressure while operating crane (TM 9-2320-279-10).</p>		
<p>If pressure is more than 3050 psi (21 mPa), remove lines (para 18-18). Remove obstructions and replace damaged lines.</p>		
<p>Step 2. Set up test gage (fig. 2-5). Operate crane (TM 9-2320-279-10). Check pressure when raising hoist with no load.</p>		
<p>If pressure is 730 psi (5 mPa) or greater, go to step 3.</p>		
<p>If pressure is lower than 730 psi (5 mPa), go to step 4.</p>		
 <p style="text-align: right; margin-right: 50px;">TA356292</p>		

Troubleshooting Malfunctions (Cont)
 Table 2-3. Troubleshooting (Cont)

Malfunction	Test or Inspection	Corrective Action
MATERIAL HANDLING CRANE (M983) (CONT)		
2. HOIST OPERATES SLOWLY OR WILL NOT LIFT LOAD (CONT).		
	Step 3. Remove hoist pilot check valve (para 18-32). Check for contamination or damage.	If there is contamination or damage, remove contamination or replace damaged pilot check valve (para 18-32).
	Step 4. Remove main control valve (para 18-41). Check for contaminated or damaged system relief valves (fig. 2-2).	If there is contamination or damage, clean or replace damaged valves (para 18-41).
	Step 5. Repair or replace hoist drive unit (paras 18-30 and 18-31).	
3. HOIST WILL NOT HOLD LOAD.		
	Step 1. Set up pressure tester (fig. 2-5). Check pressure while operating crane (TM 9-2320-279-10).	If there is 435 to 580 psi (3 to 4 mPa), repair hoist drive unit (para 18-31).
		If there is less than 1305 psi (9 mPa), disconnect hoist lines and remove any obstructions.
	Step 2. Remove control valve (para 18-41). Inspect system relief valve for contamination or damage (fig. 2-2).	Remove contamination, replace or repair damaged spool valve, or valve body (para 18-41).
	Step 3. If problem remains, repair hoist brake (para 18-31).	

Troubleshooting Malfunctions (Cont)

2-7. TROUBLESHOOTING INSTRUCTIONS (CONT).

Table 2-3. Troubleshooting (Cont)

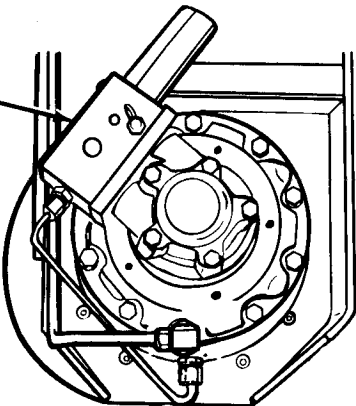
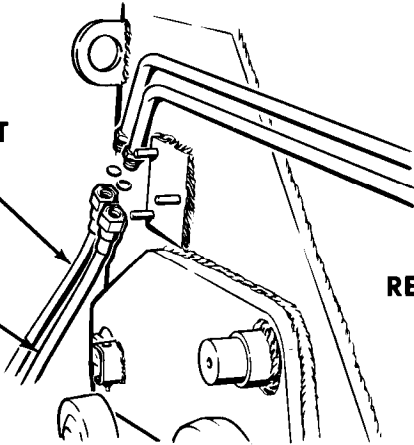
Malfunction	Test or Inspection	Corrective Action
MATERIAL HANDLING CRANE (M983) (CONT)		
4. HOIST WILL NOT LOWER LOAD.		
<p>Step 1. Set up pressure tester (fig. 2-5). Check pressure while operating crane (TM 9-2320-279-10).</p>		
<p style="padding-left: 40px;">If there is more than 435 psi (3 mPa), go to step 2.</p>		
<p style="padding-left: 40px;">If there is less than 435 psi (3 mPa), go to step 5.</p>		
<div style="display: flex; align-items: center;"> <div style="margin-right: 20px;"> <p>HOIST PILOT CHECK VALVE</p> </div>  </div> <p style="text-align: right; margin-right: 50px;">TA356292</p>		
<p>Step 2. Remove hoist pilot check valve (para 18-32). Check for contamination or damage.</p>		
<p style="padding-left: 40px;">Clean or replace hoist pilot check valve (para 18-32).</p>		
<div style="display: flex; align-items: center;"> <div style="margin-right: 20px;"> <p>HOIST OUT</p> </div> <div style="margin-right: 20px;"> <p>HOIST IN</p> </div>  <div style="margin-left: 20px;"> <p>HOSE REEL REMOVED FOR CLARITY</p> </div> </div> <p style="text-align: right; margin-right: 50px;">TA356293</p>		
<p>Step 3. Disconnect hoist IN and hoist OUT lines and check for obstructions or damage.</p>		
<p style="padding-left: 40px;">If there are obstructions, remove hoist hydraulic lines (para 18-18). Remove obstructions and replace damaged lines.</p>		

Troubleshooting Malfunctions (Cont)
 Table 2-3. Troubleshooting (Cont)

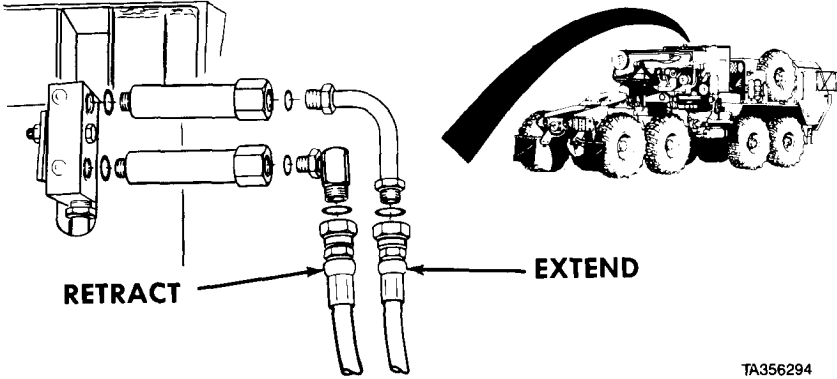
Malfunction	Test or Inspection	Corrective Action
MATERIAL HANDLING CRANE (M983) (CONT)		
4. HOIST WILL NOT LOWER LOAD (CONT).		
<p>Step 4. Set up pressure tester (fig. 2-5). Connect hoist IN and hoist OUT lines together. Check pressure while operating crane (TM 9-2320-279-10).</p>		
<p style="padding-left: 40px;">If pressure is more than 1600 psi (11 mPa), remove hoist system plugs (fig. 2-2 and para 18-41), and clean contamination from valve body.</p>		
<p style="padding-left: 40px;">If pressure is less than 1500 psi (10.3 mPa), repair hoist drive unit (para 18-31).</p>		
<p>Step 5. Remove main control valve (para 18-41). Inspect hoist operating valves for contamination or damage (fig. 2-2).</p>		
<p style="padding-left: 40px;">Clean or replace valves as required (para 18-41).</p>		
5. BOOM EXTENSIONS NO. 3 AND NO. 4 WILL NOT EXTEND OR WILL NOT FULLY EXTEND.		
		
<p>Step 1. Set up pressure tester (fig. 2-5). Disconnect extensions No. 3 and No. 4 extend and retract lines (para 18-26). Check extend and retract lines for damage. Replace damaged lines. Connect lines together, operate crane, check pressure.</p>		
<p style="padding-left: 40px;">If pressure is more than 2465 psi (17 mPa), remove lines (para 18-26). Remove restrictions.</p>		
<p>Step 2. Remove main control valve (para 18-41). Check for contamination, damaged valve spool, or sticking system relief valves (fig. 2-2).</p>		
<p style="padding-left: 40px;">Clean or replace damaged or sticking valve and valve spool (para 18-41).</p>		
<p>Step 3. If problem remains, remove extensions No. 3 and No. 4 cylinder (para 18-26). Inspect for damaged seals, check valves, or cylinder rods.</p>		
<p style="padding-left: 40px;">Repair cylinder (para 18-27).</p>		

2-7. TROUBLESHOOTING INSTRUCTIONS (CONT).

Table 2-3. Troubleshooting (Cont)

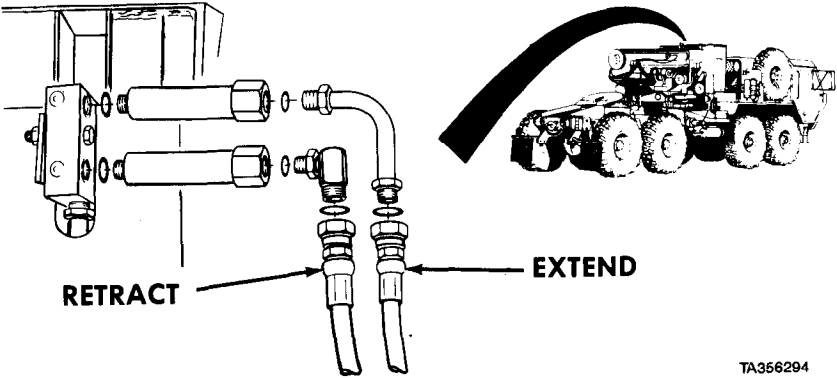
Malfunction	Test or Inspection	Corrective Action
MATERIAL HANDLING CRANE (M983) (CONT)		
6. BOOM EXTENSIONS NO. 3 AND NO. 4 WILL NOT HOLD LOAD EXTENDED OR RETRACTED OR CREEPS.	<p>Step 1. Remove main control valve (para 18-41). Inspect valve spools and system relief valves for contamination and damage (fig. 2-2).</p>	<p>Clean or replace valves and valve spools as required (para 18-41).</p>
	<p>Step 2. Repair extensions No. 3 and No. 4 cylinders (para 18-27).</p>	
7. BOOM EXTENSIONS NO. 3 AND NO. 4 WILL NOT RETRACT OR WILL NOT FULLY RETRACT.		
		<p>TA356294</p>
	<p>Step 1. Set up pressure tester (fig. 2-5). Disconnect extensions No. 3 and No. 4 extend and retract lines (para 18-26). Connect lines, operate crane, check pressure.</p>	<p>If pressure is higher than 2320 psi (16 mPa), remove lines (para 18-18). Remove restrictions or replace damaged lines.</p>
	<p>Step 2. Remove main control valve (para 18-41). Inspect valve spool and system relief valves for contamination and damage (fig. 2-2).</p>	<p>Clean or replace valves and valve spools as required (para 18-41).</p>
	<p>Step 3. Repair extensions No. 3 and No. 4 cylinders (para 18-27).</p>	

Troubleshooting Malfunctions (Cont)

Table 2-3. Troubleshooting (Cont)

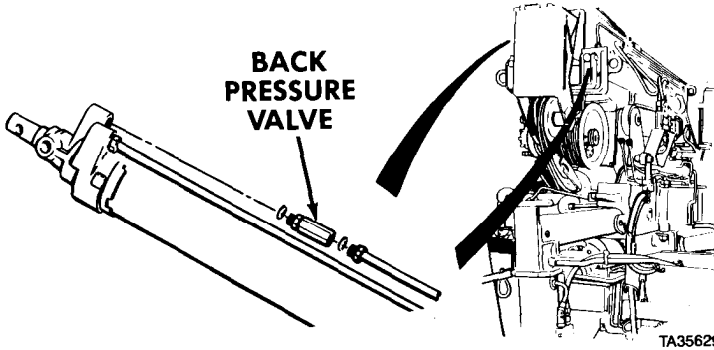
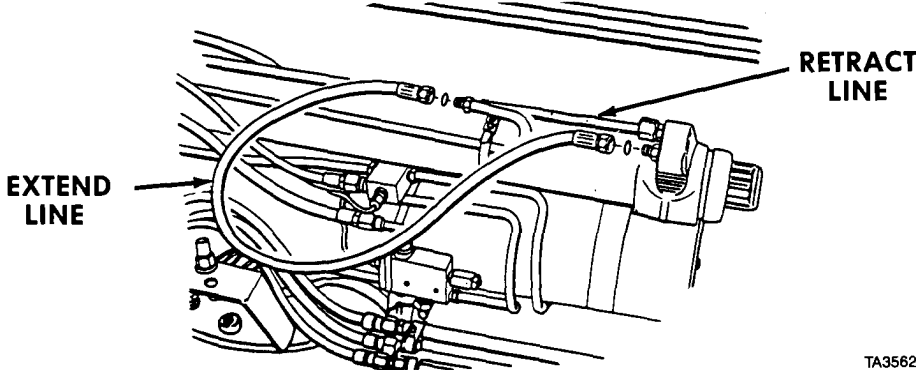
Malfunction	Test or Inspection	Corrective Action
MATERIAL HANDLING CRANE (M983) (CONT)		
8. BOOM EXTENSION NO. 1 OR NO. 2 WILL NOT EXTEND OR WILL NOT FULLY EXTEND.		
<p>Step 1. Set up pressure tester (fig. 2-5). Check pressure while trying to extend boom (TM 9-2320-279-10).</p>		
<p style="padding-left: 40px;">If pressure is 1015 psi (7 mPa) or more, go to step 2.</p>		
<p style="padding-left: 40px;">If pressure is below 1015 psi (7 mPa), go to step 4.</p>		
 <p style="text-align: center;">BACK PRESSURE VALVE</p> <p style="text-align: right; font-size: small;">TA356295</p>		
<p>Step 2. Disconnect extend lines, remove and inspect back pressure valves for contamination, damage, or sticking (para 18-28).</p>		
<p style="padding-left: 40px;">If there is contamination, clean or replace damaged or sticking valve (para 18-28).</p>		
 <p style="text-align: right;">RETRACT LINE</p> <p style="text-align: left;">EXTEND LINE</p> <p style="text-align: right; font-size: small;">TA356297</p>		
<p>Step 3. Set up pressure tester (fig. 2-5). Disconnect extend and retract lines. Connect lines together. Check pressure while trying to extend boom (TM 9-2320-279-10).</p>		
<p style="padding-left: 40px;">If pressure is more than 1015 psi (7 mPa), remove main control valve (para 18-41). Inspect system relief valves (fig. 2-2) for sticking and contamination. Clean or replace valves as required (para 18-41).</p>		
<p>Step 4. If problem remains, repair extensions No. 1 and No. 2 hydraulic cylinders (para 18-25).</p>		

Troubleshooting Malfunctions (Cont)

2-7. TROUBLESHOOTING INSTRUCTIONS (CONT).

Table 2-3. Troubleshooting (Cont)

Malfunction	Test or Inspection	Corrective Action
MATERIAL HANDLING CRANE (M983) (CONT)		
9. BOOM EXTENSION NO. 1 OR NO. 2 WILL NOT HOLD LOAD EXTENDED OR RETRACTED, OR CREEPS.		<div data-bbox="417 649 1146 1000" data-label="Image"> </div> <p data-bbox="208 1027 1458 1089">Step 1. Remove back pressure valves (para 18-28). Check for contamination, damage, or stuck open valve.</p> <p data-bbox="429 1102 1428 1164" style="padding-left: 40px;">Remove any contamination, replace damaged or stuck open back pressure valve (para 18-28).</p> <p data-bbox="208 1187 1425 1249">Step 2. Remove main control valve (para 18-41). Inspect valve spools and system relief valves for contamination, sticking, or damage (fig. 2-2).</p> <p data-bbox="429 1261 1030 1291" style="padding-left: 40px;">Clean or replace valves as required (para 18-41).</p> <p data-bbox="208 1312 1389 1344">Step 3. If problem remains, repair extensions No. 1 and No. 2 hydraulic cylinders (para 18-25).</p>

Troubleshooting Malfunctions (Cont)

Table 2-3. Troubleshooting (Cont)

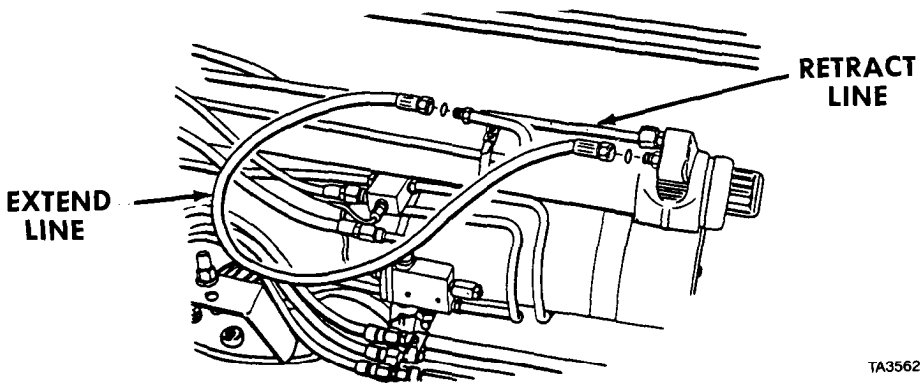
Malfunction Test or Inspection	Corrective Action
MATERIAL HANDLING CRANE (M983) (CONT)	
10. BOOM EXTENSIONS NO. 1 AND NO. 2 WILL NOT RETRACT OR WILL NOT FULLY RETRACT.	
<p>Step 1. Set up pressure tester (fig. 2-5). Check pressure while operating crane (TM 9-2320-279-10).</p> <p style="padding-left: 40px;">If pressure is higher than 2465 psi (17 mPa), go to step 2.</p> <p style="padding-left: 40px;">If pressure is lower than 2465 psi (17 mPa), go to step 4.</p>	
 <p>The diagram shows a hydraulic valve assembly with two main lines. One line is labeled 'EXTEND LINE' and the other is labeled 'RETRACT LINE'. The assembly includes various fittings, seals, and a central valve body. The lines are connected to the valve body and extend outwards.</p>	<p style="text-align: right;">RETRACT LINE</p> <p style="text-align: left;">EXTEND LINE</p> <p style="text-align: right;">TA356297</p>
<p>Step 2. Disconnect extend and retract lines separately. Check for obstructions and damage.</p> <p style="padding-left: 40px;">Remove any obstructions or replace damaged lines (para 18-24).</p>	
<p>Step 3. Remove back pressure valves (para 18-28). Check for contamination, damage, and sticking valves.</p> <p style="padding-left: 40px;">Remove contamination. Repair or replace damaged or sticking back pressure valve (para 18-28).</p>	

Troubleshooting Malfunctions (Cont)

2-7. TROUBLESHOOTING INSTRUCTIONS (CONT).

Table 2-3. Troubleshooting (Cont)

Malfunction	Test or Inspection	Corrective Action
MATERIAL HANDLING CRANE (M983) (CONT)		
10. BOOM EXTENSIONS NO. 1 AND NO. 2 WILL NOT RETRACT OR WILL NOT FULLY RETRACT (CONT).		<div data-bbox="310 640 1096 1019" data-label="Image"> <p>A technical drawing showing a side view of a crane boom extension hydraulic cylinder and its associated valve assembly. A line labeled 'EXTEND LINE' points to a specific hydraulic line connected to the cylinder.</p> </div> <p data-bbox="1129 998 1202 1017" style="text-align: right;">TA356296</p> <p data-bbox="199 1055 1422 1115">Step 4. Disconnect extend line. Operate crane (TM 9-2320-279-10). Operate crane boom extensions No. 1 and No. 2 levers. Check if oil flows from cylinders.</p> <p data-bbox="419 1127 1265 1159" style="padding-left: 40px;">If oil flows, repair extensions No. 1 and No. 2 cylinders (para 18-25).</p> <p data-bbox="199 1181 1405 1240">Step 5. Remove main control valve (para 18-41). Inspect valve spools and system relief valves for contamination or damage (fig. 2-2).</p> <p data-bbox="419 1255 1224 1287" style="padding-left: 40px;">Clean or replace valves and valve spools as required (para 18-41).</p> <p data-bbox="199 1308 1001 1340">Step 6. Repair extensions No. 1 and No. 2 cylinders (para 18-25).</p>
11. BOOM WILL NOT LOWER OR WILL NOT LOWER COMPLETELY.		<div data-bbox="492 1449 1062 1821" data-label="Image"> <p>A technical drawing showing a side view of a crane boom hydraulic cylinder and its associated valve assembly. Two lines are labeled: 'RETRACT LINE' pointing to a line on the left side of the cylinder, and 'EXTEND LINE' pointing to a line on the right side of the cylinder.</p> </div> <p data-bbox="984 1806 1057 1825" style="text-align: right;">TA356306</p>

Troubleshooting Malfunctions (Cont)

Table 2-3. Troubleshooting (Cont)

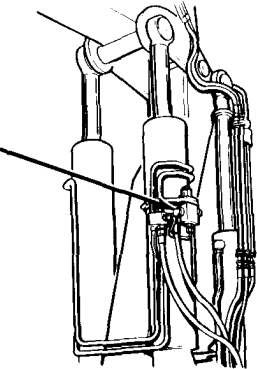
Malfunction Test or Inspection	Corrective Action
MATERIAL HANDLING CRANE (M983) (CONT)	
11. BOOM WILL NOT LOWER OR WILL NOT LOWER COMPLETELY (CONT).	
Step 1. Remove retract line (para 18-18).	Clear any obstructions from lines.
Step 2. Set up pressure tester (fig. 2-5). Disconnect extend and retract lines. Connect lines together. Operate crane inner boom lever (TM 9-2320-279-10) and check pressure.	If there is more than 2200 psi (15.2 mPa), remove extend line, clear any restrictions, then remove A2/B2 system relief valves (para 18-38), remove contamination.
	If pressure is low, go to step 3.
 <p data-bbox="1026 1242 1102 1257">TA356305</p>	
Step 3. Support boom. Remove overload protection valve (para 18-12). Check if boom will lower with no power.	If boom lowers, repair or replace overload protection valve (para 18-12).
	If boom does not lower, remove main control valve (para 18-41). Inspect valve spool and system relief valves for contamination or damage (fig. 2-2). Clean or replace valves and valve spool as required (para 18-41).
Step 4. Repair inner boom cylinders (para 18-23).	

Troubleshooting Malfunctions (Cont)

2-7. TROUBLESHOOTING INSTRUCTIONS (CONT).

Table 2-3. Troubleshooting (Cont)

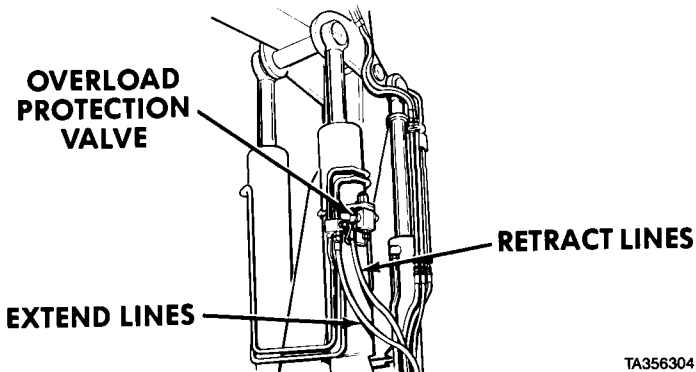
Malfunction Test or Inspection	Corrective Action
MATERIAL HANDLING CRANE (M983) (CONT)	
12. BOOM WILL NOT GO TO MAXIMUM HEIGHT.	
<p>Step 1. Set up pressure tester (fig. 2-5). Check pressure while operating crane (TM 9-2320-279-10). If pressure is higher than 2175 psi (15 mPa), go to step 2. If pressure is lower than 2175 psi (15 mPa), go to step 3.</p>	
 <p>The diagram shows a section of the crane's hydraulic system. It features a vertical cylinder with various lines connected to it. Three labels with leader lines point to specific components: 'OVERLOAD PROTECTION VALVE' points to a valve on the left side of the cylinder; 'EXTEND LINES' points to a bundle of lines extending downwards from the bottom of the cylinder; and 'RETRACT LINES' points to a bundle of lines extending to the right from the middle of the cylinder.</p>	
TA356304	
<p>Step 2. Disconnect extend lines and check for obstructions or damage to lines. Remove any obstructions and replace damaged line (para 18-18).</p> <p>Step 3. Support boom. Remove overload protection valve (para 18-12). Check for damaged, sticking, or contaminated valve. Remove any contamination, repair, or replace damaged or sticking overload protection valve (para 18-12).</p> <p>Step 4. Disconnect retract line. Operate crane (TM 9-2320-279-10). Operate inner boom controls. Check if cylinders extend. If cylinders extend, remove retract lines (para 18-18), clear any restrictions in lines. If cylinders do not extend, do steps 5 and 6.</p> <p>Step 5. Remove main control valve (para 18-41), inspect valve spool and system relief valves for contamination and/or damage (fig. 2-2). Clean or replace valves and valve spool as required (para 18-41).</p> <p>Step 6. Remove inner boom cylinders (para 18-22). Check for damage to seals or rods. Repair inner boom cylinders (para 18-23).</p>	

Troubleshooting Malfunctions (Cont)

Table 2-3. Troubleshooting (Cont)

Malfunction	Test or Inspection	Corrective Action
MATERIAL HANDLING CRANE (M983) (CONT)		
13. BOOM WILL NOT LIFT LOAD.		
<p>Step 1. Set up pressure tester (fig. 2-5). Check pressure while trying to raise boom (TM 9-2320-279-10).</p>		
<p style="padding-left: 40px;">If pressure is higher than 2685 psi (18.5 mPa), go to step 2.</p>		
<p style="padding-left: 40px;">If pressure is lower than 1305 psi (9 mPa), go to step 7.</p>		
<p>Step 2. Disconnect extend lines. Check for obstructions or damage to lines.</p>		
<p style="padding-left: 40px;">Remove obstructions and replace damaged lines (para 18-18).</p>		
<p>Step 3. Support boom. Remove overload protection valve (para 18-12). Check for damaged, sticking, or contaminated valve or valve body.</p>		
<p style="padding-left: 40px;">Clean or replace damaged or sticking overload protection valve (para 18-12).</p>		

Troubleshooting Malfunctions (Cont)

2-7. TROUBLESHOOTING INSTRUCTIONS (CONT.)

Table 2-3. Troubleshooting (Cont)

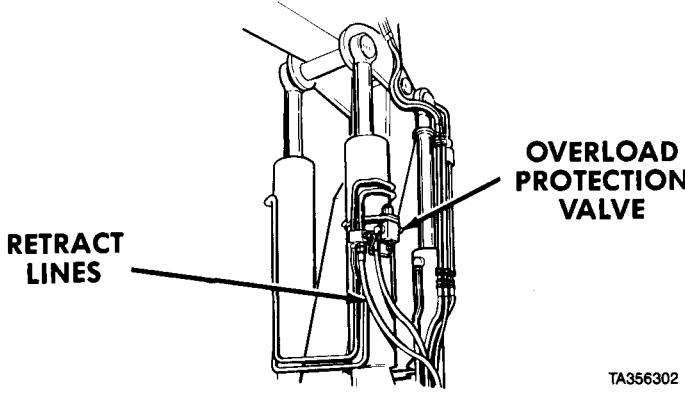
Malfunction Test or Inspection	Corrective Action
MATERIAL HANDLING CRANE (M983) (CONT)	
13. BOOM WILL NOT LIFT LOAD (CONT).	
 <p style="text-align: right; margin-right: 100px;">TA356302</p>	
<p>Step 4. Disconnect retract lines. Operate inner boom controls (TM 9-2320-279-10). Check if cylinders extend.</p>	<p style="padding-left: 40px;">If cylinders extend, remove retract lines (para 18-18), clear restrictions in lines. If cylinders do not extend, do steps 5 and 6.</p> <p>Step 5. Remove main control valve (para 18-41). Inspect valve spool and system relief valves for contamination and damage (fig. 2-2). Clean or replace valves and valve spool as required (para 18-41).</p> <p>Step 6. Remove inner boom cylinders (para 18-22). Check for worn or damaged seals or rods. Repair inner boom cylinders (para 18-23).</p> <p>Step 7. Support boom, remove overload protection valve (para 18-12). Check for contaminated, damaged, or sticking valve. Clean or replace damaged or sticking overload protection valve (para 18-12).</p> <p>Step 8. Remove main control valve (para 18-41). Inspect valve spool and system relief valves for contamination and damage (fig. 2-2). Clean or replace valves and valve spool as required (para 18-41).</p> <p>Step 9. Remove inner boom cylinders (para 18-22). Check for worn or damaged seals or rods. Repair inner boom cylinders (para 18-23).</p>

Troubleshooting Malfunctions (Cont)

Table 2-3. Troubleshooting (Cont)

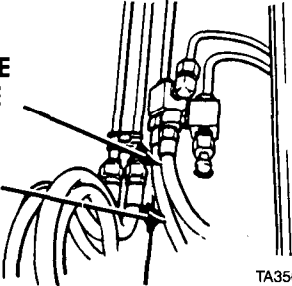
Malfunction	Test or Inspection	Corrective Action
MATERIAL HANDLING CRANE (M983) (CONT)		
14. BOOM LOWERS UNDER LOAD OR WILL NOT HOLD LOAD.		
Step 1. Remove overload protection valve (para 18-12). Check for contamination, damaged, or sticking valve.	Remove contamination and clean or replace damaged or sticking overload protection valve (para 18-12).	
Step 2. Remove main control valve (para 18-41). Inspect valve spool and system relief valves for contamination and damage (fig. 2-2).	Clean or replace sticking or damaged valves and valve spool as required (para 18-41).	
Step 3. Repair inner boom cylinders (para 18-23).		
15. CRANE WILL NOT UNFOLD OR WILL NOT UNFOLD COMPLETELY.		
Step 1. Set up pressure tester (fig. 2-5). Check pressure while trying to unfold crane (TM 9-2320-279-10).	If pressure is higher than 365 psi (2.5 mPa), go to step 2.	If pressure is lower than 365 psi (2.5 mPa), go to step 5.
 <p style="text-align: right; margin-right: 50px;">TA356307</p>		
Step 2. Set up pressure tester (fig. 2-5). Disconnect raise line. Connect raise and lower lines together. Check pressure while operating controls (TM 9-2320-279-10).	If pressure is higher than 600 psi (4.1 mPa), remove lines (para 18-18), clear any restrictions, replace damaged lines.	If pressure is lower than 600 psi (4.1 mPa), do steps 3 and 4.
Step 3. Remove main control valve (para 18-41). Inspect for contaminated or damaged valve spool and system relief valves (fig. 2-2).	Clean or replace sticking or damaged valve spool and system relief valves (para 18-41).	

Troubleshooting Malfunctions (Cont)

2-7. TROUBLESHOOTING INSTRUCTIONS (CONT).

Table 2-3. Troubleshooting (Cont)

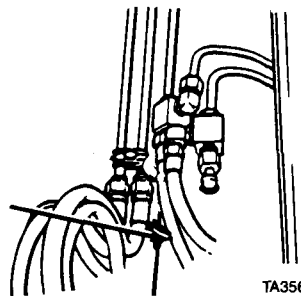
Malfunction Test or Inspection	Corrective Action
MATERIAL HANDLING CRANE (M983) (CONT)	
15. CRANE WILL NOT UNFOLD OR WILL NOT UNFOLD COMPLETELY (CONT).	
<p>Step 4. Set up pressure tester (fig. 2-5). Disconnect raise and lower lines. Check for main system pressure of 175 psi (1.2 mPa) while operating crane (TM 9-2320-279-10).</p>	<p>If main system pressure is okay, repair unfolding cylinders (para 18-21). If system pressure is less than 175 psi (1.2 mPa), do steps 5 and 6.</p>
<p>Step 5. Remove main control valve (para 18-41). Inspect valve spool and system relief valves for contamination and damage (fig. 2-2).</p>	<p>Clean or replace valves as required (para 18-41).</p>
<p>Step 6. Disconnect lower line. Check for oil flowing from cylinders while trying to unfold crane (TM 9-2320-279-10).</p>	<p>If oil is leaking, seals are bad. Repair unfolding cylinders (para 18-21).</p>
16. CRANE WILL NOT FOLD COMPLETELY OR FOLDS SLOWLY.	
<p>Step 1. Set up pressure tester (fig. 2-5). Check pressure while trying to fold crane (TM 9-2320-279-10).</p>	<p>If pressure is higher than 1670 psi (11.5 mPa), go to step 2. If pressure is lower than 1670 psi (11.5 mPa), go to step 5.</p>
 <p style="text-align: right; margin-right: 50px;">TA356308</p>	
<p>Step 2. Disconnect lower line. Check line for obstructions. Remove lower line (para 18-18) and clear any obstructions.</p>	

Troubleshooting Malfunctions (Cont)
 Table 2-3. Troubleshooting (Cont)

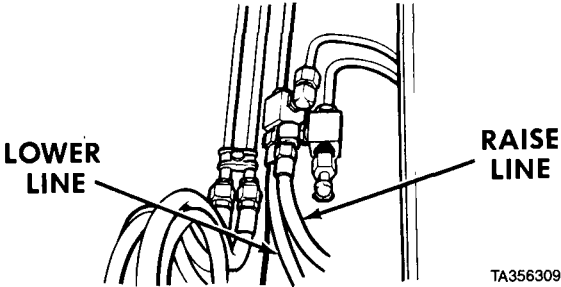
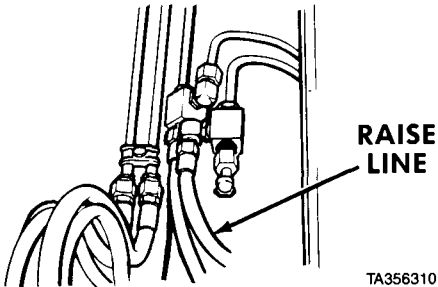
Malfunction	Test or Inspection	Corrective Action
MATERIAL HANDLING CRANE (M983) (CONT)		
16. CRANE WILL NOT FOLD COMPLETELY OR FOLDS SLOWLY (CONT).		
 <p style="text-align: right; margin-right: 50px;">TA356309</p>		
<p>Step 3. Set up pressure tester (fig. 2-5). Disconnect raise and lower lines. Connect lines together. Check pressure while operating crane (TM 9-2320-279-10).</p>		
<p style="padding-left: 40px;">If pressure is higher than 1670 psi (11.5 mPa), remove raise lines (para 18-18), clear any obstructions, replace damaged lines.</p>		
<p style="padding-left: 40px;">If pressure is lower than 1670 psi (11.5 mPa), do steps 4 and 5.</p>		
<p>Step 4. Remove main control valve (para 18-41). Inspect valve spool and system relief valves for contamination and damage (fig. 2-2).</p>		
<p style="padding-left: 40px;">Clean or replace damaged or sticking valves and valve spool (para 18-41).</p>		
 <p style="text-align: right; margin-right: 50px;">TA356310</p>		
<p>Step 5. Disconnect raise line. Operate unfolding lever (TM 9-2320-279-10). Check for oil flow out of cylinders.</p>		
<p style="padding-left: 40px;">Repair unfolding cylinders (para 18-21).</p>		
<p>Step 6. Remove main control valve (para 18-41). Inspect valve spool and system relief valves for contamination or damage (fig. 2-2).</p>		
<p style="padding-left: 40px;">Clean or replace valves and valve spool as required (para 18-41).</p>		

Troubleshooting Malfunctions (Cont)

2-7. TROUBLESHOOTING INSTRUCTIONS (CONT).

Table 2-3. Troubleshooting (Cont)

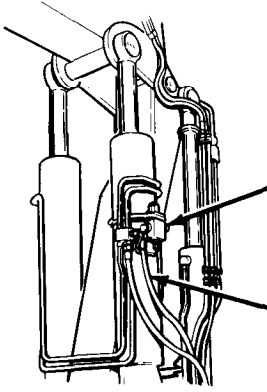
Malfunction Test or Inspection	Corrective Action
MATERIAL HANDLING CRANE (M983) (CONT)	
17. CRANE FOLDS TOO QUICKLY (FALLS WHEN FOLDING).	
Step 1. Remove main control valve (para 18-41). Inspect valve spool and system relief valves for contamination or damage (fig. 2-2).	Clean or replace valves and valve spool as required (para 18-41).
Step 2. Repair unfolding cylinders (para 18-21).	
18. BOOM MOVES SLOWLY.	
Step 1. Set up pressure tester (fig. 2-5). Check pressure while raising and lowering boom (TM 9-2320-279-10).	If pressure is higher than 1305 psi (9 mPa) when raising boom, do steps 2 through 6.
	If pressure is lower than 1305 psi (9 mPa) when raising boom, go to step 12.
	If pressure is higher than 2175 psi (15 mPa) when lowering boom, do steps 7 through 11.
 <p data-bbox="784 1287 958 1372">OVERLOAD PROTECTION VALVE</p> <p data-bbox="776 1436 925 1468">RAISE LINE</p> <p data-bbox="941 1521 1015 1542">TA356298</p>	
Step 2. Disconnect raise line. Check for obstructions or damage to lines.	Remove obstructions and replace damaged lines (para 18-18).
Step 3. Support boom. Remove overload protection valve (para 18-12). Check for damaged, sticking, or contaminated valve.	Remove contamination, repair or replace damaged or sticking overload protection valve (para 18-12).

Troubleshooting Malfunctions (Cont)
 Table 2-3. Troubleshooting (Cont)

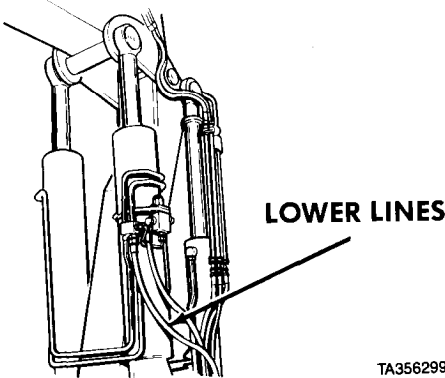
Malfunction	Test or Inspection	Corrective Action
MATERIAL HANDLING CRANE (M983) (CONT)		
18. BOOM MOVES SLOWY (CONT).		
 <p style="text-align: right; margin-right: 100px;">TA356299</p>		
<p>Step 4. Disconnect lower line. Operate inner boom controls (TM 9-2320-279-10). Check if cylinders extend.</p> <p style="padding-left: 40px;">If cylinders extend, remove lower lines (para 18-18). Clear any restrictions in lines, replace damaged lines.</p> <p style="padding-left: 40px;">If cylinders do not extend, go to step 6.</p> <p>Step 5. Remove main control valve (para 18-41). Inspect valve spool and system relief valves for contamination and damage (fig. 2-2).</p> <p style="padding-left: 40px;">Clean or replace valves and valve spool as required (para 18-41).</p> <p>Step 6. Remove inner boom cylinders (para 18-22). Check for worn or damaged seals and rods.</p> <p style="padding-left: 40px;">Repair inner boom cylinders (para 18-23).</p>		

2-7. TROUBLESHOOTING INSTRUCTIONS (CONT).

Table 2-3. Troubleshooting (Cont)

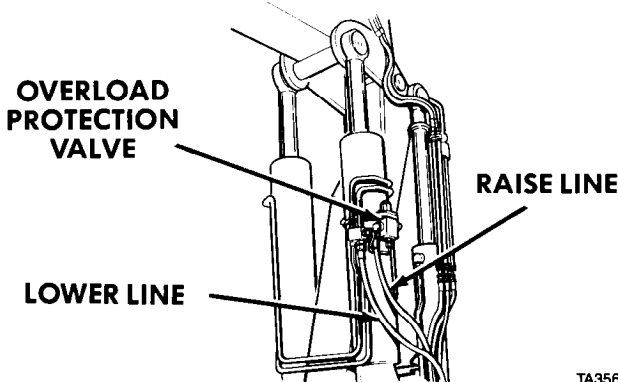
Malfunction	Test or Inspection	Corrective Action
MATERIAL HANDLING CRANE (M983) (CONT)		
18. BOOM MOVES SLOWLY (CONT).		
 <p>The diagram shows a hydraulic cylinder with three lines connected to it. A line at the top is labeled 'OVERLOAD PROTECTION VALVE'. A line at the bottom left is labeled 'LOWER LINE'. A line at the bottom right is labeled 'RAISE LINE'. The diagram is identified by the number 'TA356300' in the bottom right corner.</p>		
	<p>Step 7. Disconnect lower lines. Check for obstructions or damage to lines. Remove obstructions and replace damaged lines (para 18-18).</p> <p>Step 8. Set up pressure tester (fig. 2-5). Disconnect raise and lower lines. Connect lines together and check pressure down and up while operating crane (TM 9-2320-279-10). If pressure is higher than 1305 psi (9 mPa) while lowering boom, remove raise lines (para 18-18), clear obstructions or replace damaged lines. If pressure is lower than 1305 psi (9 mPa) while lowering or raising, go to step 11.</p> <p>Step 9. Remove main control valve (para 18-41). Inspect valve spool and system relief valves for contamination and damage (fig. 2-2). Clean or replace valves and valve spool as required (para 18-41).</p> <p>Step 10. Support boom. Remove overload protection valve (para 18-12). Check if boom lowers with no power. Repair or replace overload protection valve (para 18-12).</p>	

Troubleshooting Malfunctions (Cont)

Table 2-3. Troubleshooting (Cont)

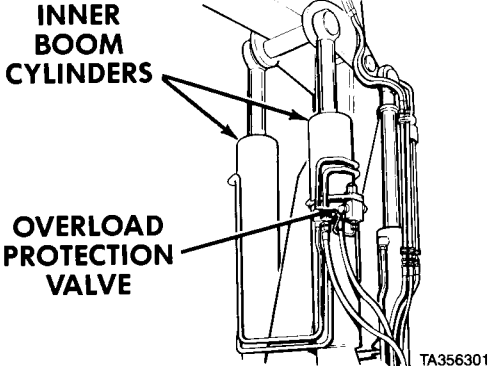
Malfunction	Test or Inspection	Corrective Action
MATERIAL HANDLING CRANE (M983) (Cont)		
18. BOOM MOVES SLOWLY (CONT).		
 <p>The diagram shows a cross-section of the crane boom's hydraulic system. Two vertical cylinders are labeled 'INNER BOOM CYLINDERS'. A valve assembly is labeled 'OVERLOAD PROTECTION VALVE'. The diagram includes various hoses, pipes, and mechanical linkages. A reference number 'TA356301' is located at the bottom right of the diagram.</p>		
<p>Step 11. Remove inner boom cylinders (para 18-22). Check for worn or damaged seals or rods. Repair inner boom cylinders (para 18-23).</p> <p>Step 12. Remove overload protection valve (para 18-12). Check for contamination, damaged, or sticking valve. Remove contamination, repair, or replace overload protection valve (para 18-12).</p> <p>Step 13. Remove main control valve (para 18-41). Inspect valves for contamination and damage (fig. 2-2). Clean or replace valves and valve spool as required (para 18-41).</p> <p>Step 14. Remove inner boom cylinders (para 18-22). Check for worn or damaged seals and rods. Repair inner boom cylinders (para 18-23).</p>		

Troubleshooting Malfunctions (Cont)

2-7. TROUBLESHOOTING INSTRUCTIONS (CONT).

Table 2-3. Troubleshooting (Cont)

Malfunction	Test or Inspection	Corrective Action
MATERIAL HANDLING CRANE (M983) (CONT)		
19. CRANE DOES NOT ROTATE.		
20. CRANE ROTATES SLOWLY IN ONE DIRECTION, BUT ROTATES NORMALLY IN OTHER DIRECTION.		
21. CRANE CREEPS CLOCKWISE OR COUNTERCLOCKWISE.		
	<p>Step 1. Operate crane (TM 9-2320-279-10). Rotate crane, hold for 15 seconds as far as it will go. Check for oil running from cylinders.</p>	<p>Replace slewing piston seals (para 18-5).</p>
	<p>Step 2. Remove constant flow valves (para 18-18). Check for contamination, damage, or sticking flow valves.</p>	<p>Remove contamination, replace damaged or sticking constant flow valves (para 18-18).</p>
	<p>Step 3. Disconnect slewing assembly hydraulic lines one at a time (para 18-18) and check for obstructions and damaged lines.</p>	<p>Remove any obstructions, replace damaged lines (para 18-18).</p>
	<p>Step 4. Remove main control valve (para 18-41). Inspect valve spool and system relief valves for contamination and damage (fig. 2-2).</p>	<p>Clean or replace valves and valve spool as required (para 18-41).</p>

Troubleshooting Malfunctions (Cont)
 Table 2-3. Troubleshooting (Cont)

Malfunction	Test or Inspection	Corrective Action
MATERIAL HANDLING CRANE (M983) (CONT)		
22. OUTRIGGER WILL NOT EXTEND OR RETRACT.		
<p>Step 1. Set up pressure tester (fig. 2-5). Check pressure on gage while operating outrigger control levers (TM 9-2320-279-10).</p>		
<p style="padding-left: 40px;">If pressure is more than 3050 psi (21 mPa), go to step 2.</p>		
<p style="padding-left: 40px;">If pressure is less than 1600 psi (11 mPa), go to step 10.</p>		
<p style="padding-left: 40px;">If outrigger will not go down, go to step 2.</p>		
<p style="padding-left: 40px;">If outrigger will not go up, go to step 7.</p>		
<p>Step 2. Disconnect outrigger down lines. Check lines for obstructions and damage.</p>		
<p style="padding-left: 40px;">Clean contamination or obstructions from lines and replace damaged lines (para 18-18).</p>		
<p>Step 3. Support outrigger cylinder. Remove pilot (check) valve (para 18-48). Check for obstructions in valve port.</p>		
<p style="padding-left: 40px;">Clean any contamination from valve, around valve seat, and replace bad check valve (para 18-48).</p>		
<p>Step 4. Disconnect outrigger up line. Check for contaminated outrigger up line.</p>		
<p style="padding-left: 40px;">Remove obstructions, replace damaged outrigger up line (para 18-18).</p>		
<p>Step 5. Remove outrigger control valve (para 18-49). Inspect valves for contamination and damage (fig. 2-3).</p>		
<p style="padding-left: 40px;">Clean or replace damaged or sticking valves (para 18-49).</p>		
<p>Step 6. Disconnect outrigger up line. Operate outrigger lever (TM 9-2320-279-10). Check if outrigger goes up.</p>		
<p style="padding-left: 40px;">If outrigger does not go up, repair faulty outrigger cylinder (para 18-48).</p>		

2-7. TROUBLESHOOTING INSTRUCTIONS (CONT).

Table 2-3. Troubleshooting (Cont)

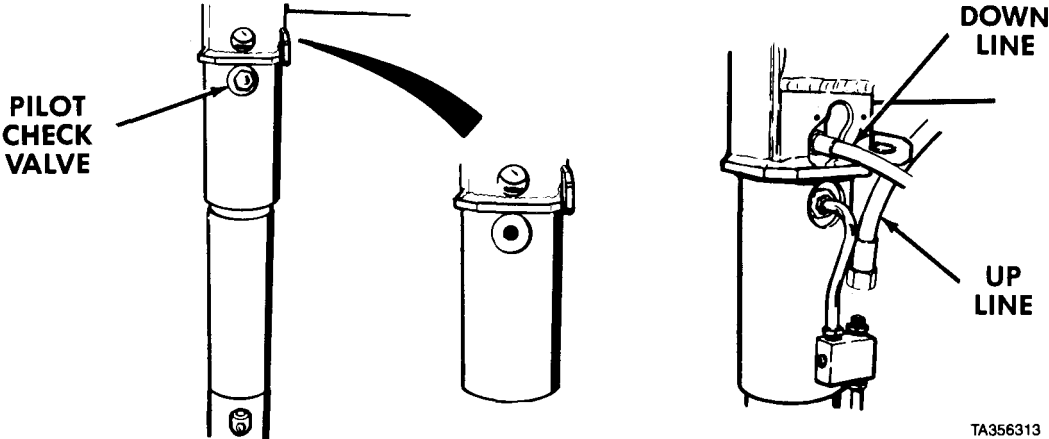
Malfunction	Test or Inspection	Corrective Action
MATERIAL HANDLING CRANE (M983) (CONT)		
22. OUTRIGGER WILL NOT EXTEND OR RETRACT (CONT).		
Step 7. Disconnect outrigger up lines. Check for obstructions in lines.		
Remove lines (para 18-18), clear restrictions, replace damaged lines.		
		
TA356313		
Step 8. Support outrigger cylinder. Remove pilot (check) valve (para 18-48). Check for contamination or sticking or damaged valve.		
Replace valve (para 18-48).		
Step 9. Set up pressure tester (fig. 2-5). Disconnect outrigger up and down lines. Connect lines together. Check for high pressure of 2900 psi (20 mPa)-up, and 290 psi (2 mPa)-down, caused by restricted down line or contaminated valve body while operating crane (TM 9-2320-279-10).		
If pressure is higher than 2900 psi (20 mPa)-up, or 290 psi (2 mPa)-down, replace restricted extend line or repair outrigger control valve (para 18-49).		
If pressure is lower than 2900 psi (20 mPa)-up, or 290 psi (2 mPa)-down, outrigger cylinder seals are bad. Repair faulty outrigger cylinder (para 18-48).		
Step 10. If outrigger will not go down, go to step 11. If outrigger will not go up, go to step 14.		
Step 11. Disconnect outrigger up line. Operate outrigger (TM 9-2320-279-10). Check for oil flowing from cylinders.		
Seals are bad. Repair outrigger cylinder (para 18-48).		
Step 12. Remove faulty outrigger leg valve spool (fig. 2-3 and para 18-48). Check for damage and contamination.		
Clear any contamination and replace bad valve spool (para 18-48).		

Troubleshooting Malfunctions (Cont)
 Table 2-3. Troubleshooting (Cont)

Malfunction	Test or Inspection	Corrective Action
-------------	--------------------	-------------------

MATERIAL HANDLING CRANE (M983) (CONT)

22. OUTRIGGER WILL NOT EXTEND OR RETRACT (CONT).

Step 13. Disconnect outrigger up line, operate outrigger control valve (TM 9-2320-279-10). Check for oil flowing from cylinder.

Outrigger leg seals are bad. Repair faulty outrigger leg (para 18-48).

Step 14. Remove outrigger control valve (para 18-49). Check for contamination and damaged or sticking valves (fig. 2-3).

Clean or replace damaged or sticking valves (para 18-49).

23. OUTRIGGER WILL NOT SUPPORT LOAD OR CREEPS UPWARD.

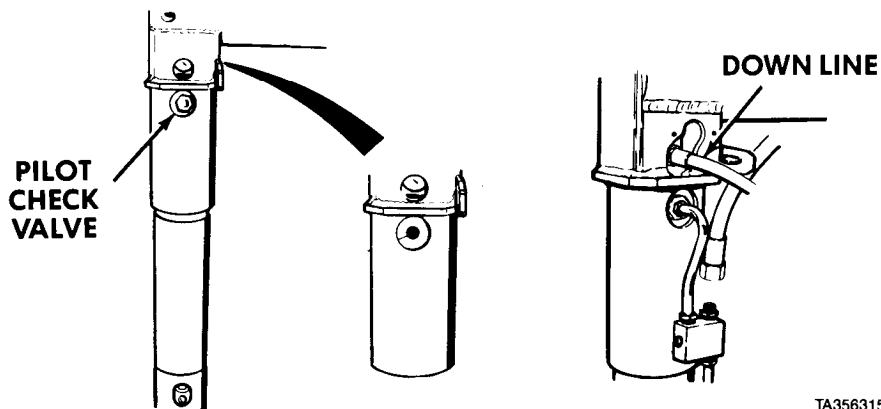

Step 1. Disconnect outrigger down line. Look for stuck open pilot (check) valve.

Clean or replace pilot valve (para 18-48).

Step 2. Remove outrigger control valve (para 18-49). Inspect valves for contamination or damage (fig. 2-3).

Clean or replace valves as required (para 18-49). If there is no damage to valves, outrigger seals are bad. Repair faulty outrigger leg (para 18-48).

Troubleshooting Malfunctions (Cont)

7. TROUBLESHOOTING INSTRUCTIONS (CONT).

Table 2-3. Troubleshooting (Cont)

Malfunction Test or Inspection	Corrective Action
MATERIAL HANDLING CRANE (M983) (CONT)	
24. CRANE OPERATING LEVERS NOT MOVING IN REMOTE CONTROL.	
<p>The diagram illustrates the electrical connections between four main components: a Tilt Alarm Box on the left, a Crane Control Box on the right, an Electronic Module Wiring Harness in the center, and a Remote Controller at the bottom. Arrows point from the labels to the respective parts in the assembly.</p>	
TA356316	
NOTE	
<p>Remote controller power tolerance is very small. If voltage drops below 24 vdc, remote controller operation may be erratic. Voltage must be checked inside crane control box or on terminal boards in tilt alarm box.</p>	
<p>Step 1. Check all electronics — cables, tilt alarm box, remote controller, and crane control box for visible signs of electrical or mechanical damage (fig. 2-5).</p>	
<p>Replace or repair damaged component (Chapters 6 and 18).</p>	
<p>The diagram shows a mechanical assembly of a dump valve solenoid, with a label pointing to the main body of the device.</p>	
DUMP VALVE SOLENOID	
TA356317	

Troubleshooting Malfunctions (Cont)

Table 2-3. Troubleshooting (Cont)

Malfunction
Test or Inspection

Corrective Action

MATERIAL HANDLING CRANE (M983) (CONT)

24. CRANE OPERATING LEVERS NOT MOVING IN REMOTE CONTROL (CONT).

Step 2. Open crane control box fuse compartment cover (para 18-35). Check for blown main fuse.

Replace defective fuse (para 18-34).

Step 3. Check dump valve solenoid for power and listen for clicking sound indicating solenoid is working when power is turned on (TM 9-2320-279-10).

If there is no power, or clicking is not heard, replace dump valve solenoid (para 18-16).

Step 4. Set multimeter to X1K. Check electronic module wiring harness for continuity.

If any wire is open, or there is other damage, repair electronic module wiring harness (para 18-35).

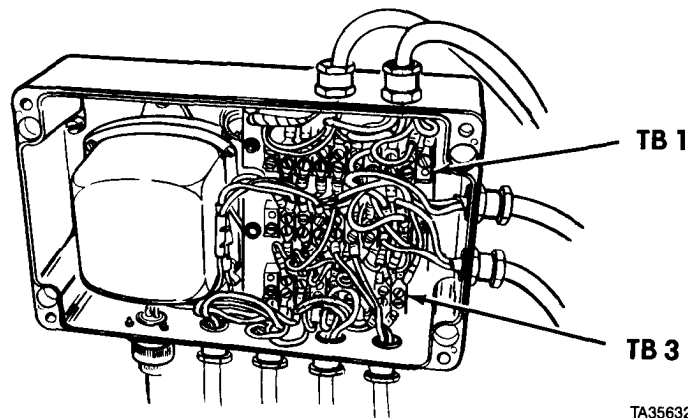

Step 5. Set multimeter to test for 18 to 30 vdc. Check crane control distribution board for 24 vdc at TB1-7 and TB3-6 and 7 (fig. 2-6), when power is turned on (TM 9-2320-279-10).

If no voltage, repair main power cable to controller box (para 6-9).

Step 6. Set multimeter to X1K. Check wiring for continuity from crane control distribution board, through filter circuit board, to relay circuit board (fig. 2-6).

Repair defective wiring (FM 55-506-1).

Step 7. Check remote controller cable for continuity.

Repair defective remote controller cable (FM 55-506-1).

Step 8. Check remote controller ON/OFF switch for continuity.

Replace defective remote controller ON/OFF switch (para 18-46).

Troubleshooting Malfunctions (Cont)

2-7. TROUBLESHOOTING INSTRUCTIONS (CONT).

Table 2-3. Troubleshooting (Cont)

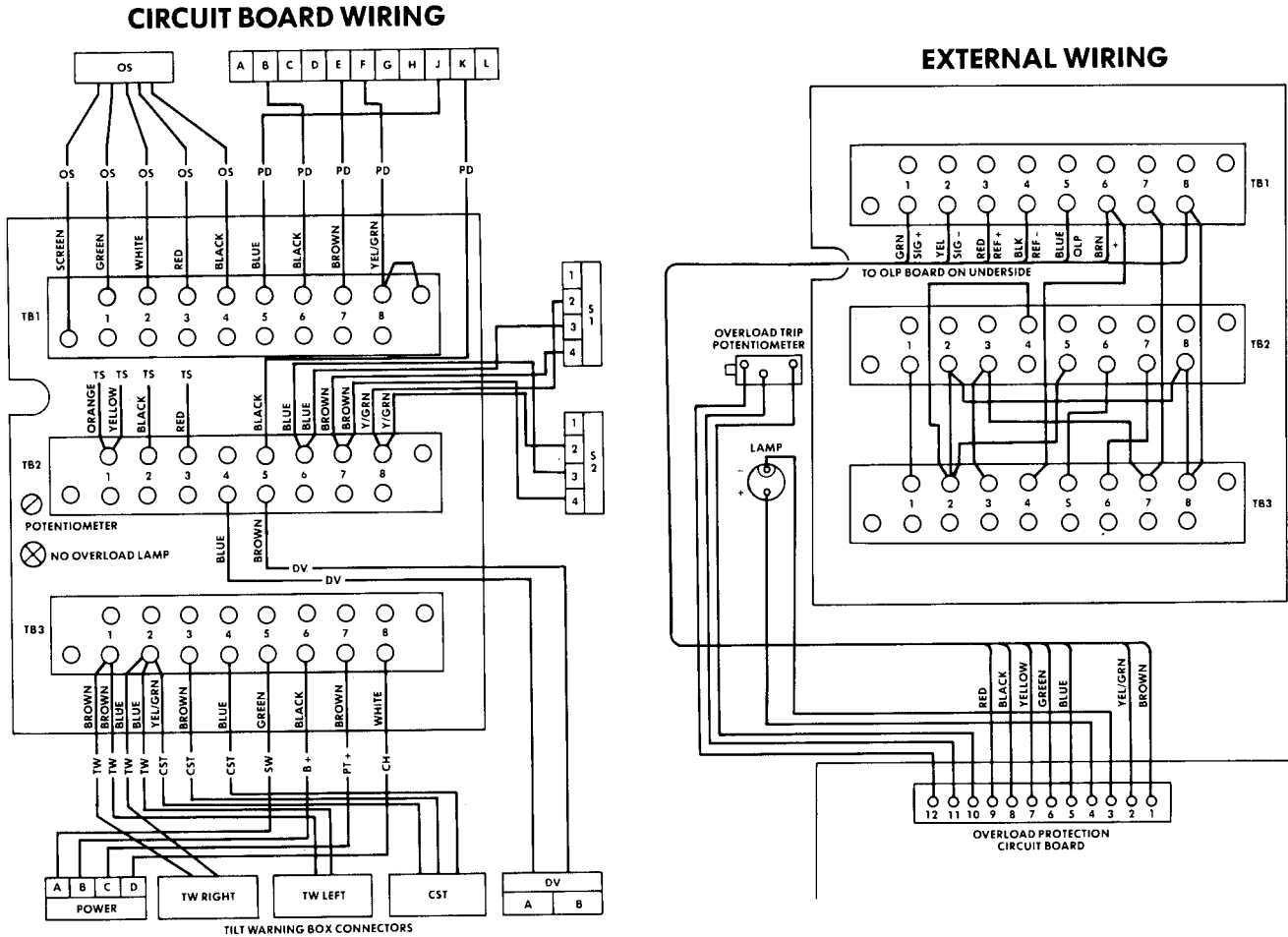

TA356318

NOTE

Wiring diagram separated into external wiring and circuit board wiring for clarity.

ABBREVIATIONS

- OS LOAD CELL AXIS/OVERLOAD SENSOR
- PD POWER DISTRIBUTION BOX
- TS TILT SWITCH
- S1 SUPPORT LEG SWITCH 1
- S2 SUPPORT LEG SWITCH 2
- TW TILT WARNING LAMPS AND HORN
- SW SUPPORT LEG WARNING LAMP - 24 VOLT

ABBREVIATIONS

- B+ +24 VOLT FUSED
- PT+ +24 VOLT WHEN PUMP IS RUNNING
- CH CHASSIS - 24 VOLT
- CST CONTROLLER STOWAGE BOX
- DV DUMP VALVE SOLENOID
- OLP OVERLOAD PROTECTION

Figure 2-6. Power Distribution Board Wiring Diagram (M983).

Troubleshooting Malfunctions (Cont)

Table 2-3. Troubleshooting (Cont)

Malfunction	Test or Inspection	Corrective Action
MATERIAL HANDLING CRANE (M983) (CONT)		
25. CRANE WILL NOT OPERATE IN ONE OR MORE REMOTE CONTROL FUNCTIONS.		
TA356319		
NOTE		
<p>Remote controller requires 24 vdc to operate properly. If battery voltage is less than 24 vdc, service batteries (TM 9-6140-200-14).</p>		
<p>Step 1. Remove fuse cover (para 18-35). Check for blown function fuse.</p>		
<p style="padding-left: 40px;">If fuse is not blown, go to step 2.</p>		
<p style="padding-left: 40px;">If fuse is blown, install new fuse, go to step 3.</p>		
<p>Step 2. Remove crane control box cover (para 18-35). Set multimeter to X1K. Check for defective wiring.</p>		
<p style="padding-left: 40px;">If wiring is defective, repair wiring (FM 55-506-1), then go to step 3.</p>		
<p>Step 3. Perform electronic module test (para 18-36).</p>		
<p style="padding-left: 40px;">If module passes test, go to step 4.</p>		
<p style="padding-left: 40px;">If module does not pass test, go to MALFUNCTION 27.</p>		
<p>Step 4. Remove electric motor and gearcase (para 18-35). Check that motor runs in both directions and for noisy gears when motor tester is used (figs. 2-7 and 2-8).</p>		
<p style="padding-left: 40px;">If motor does not pass check, replace motor.</p>		
<p style="padding-left: 40px;">If motor passes check, check for sticking controls in crane control box and repair sticking controls (para 18-35).</p>		

Troubleshooting Malfunctions (Cont)

2-7. TROUBLESHOOTING INSTRUCTIONS (CONT).

Table 2-3. Troubleshooting (Cont)

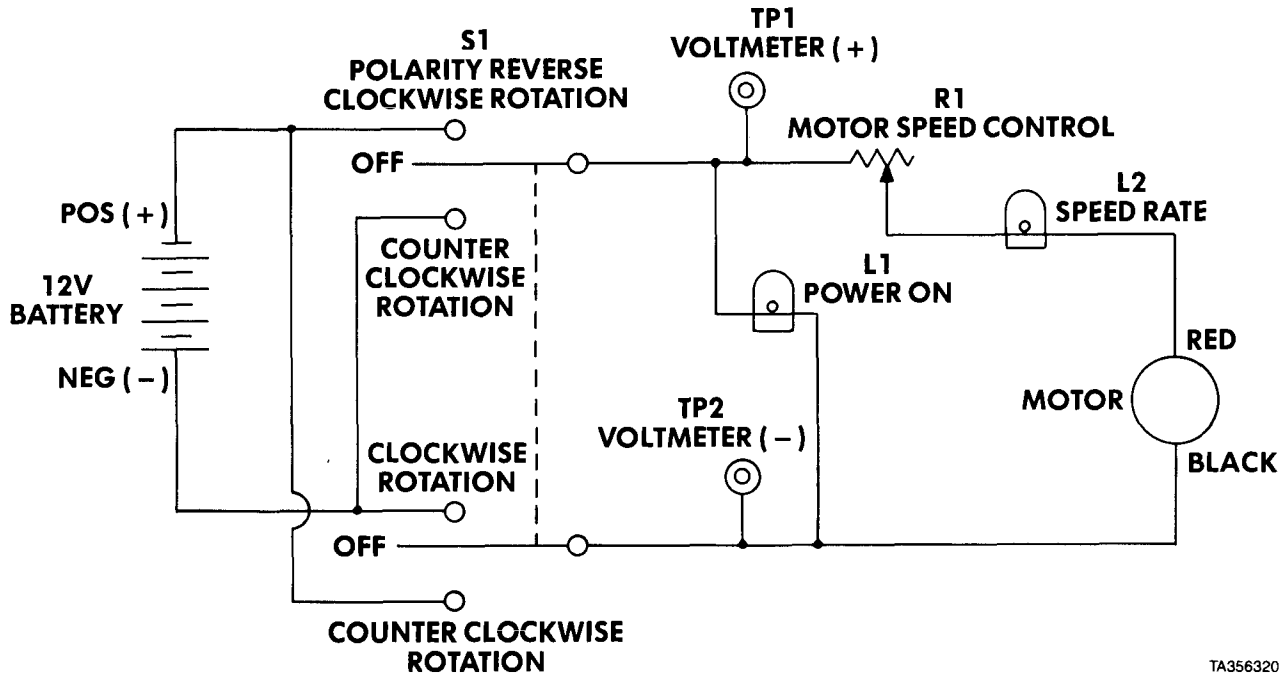

TA356320

Parts List

1. S1 = Double Pole, Double Throw Switch (CENTER OFF), rated at 50 VDC Min.
2. R1 = 1000 ohm, 5W Potentiometer
3. L1, L2 = Lamp, 12 V, Miniature, Red and Green Lens
4. TP1, TP2 = Banana-type test jack (2) Red and Black
5. Alligator clips (4 ea)
6. Wire, AWG 18, Red
7. Wire, AWG 18, Black

Figure 2-7. 12V Electric Motor Tester Circuit Schematic (M983).

Troubleshooting Malfunctions (Cont)
 Table 2-3. Troubleshooting (Cont)

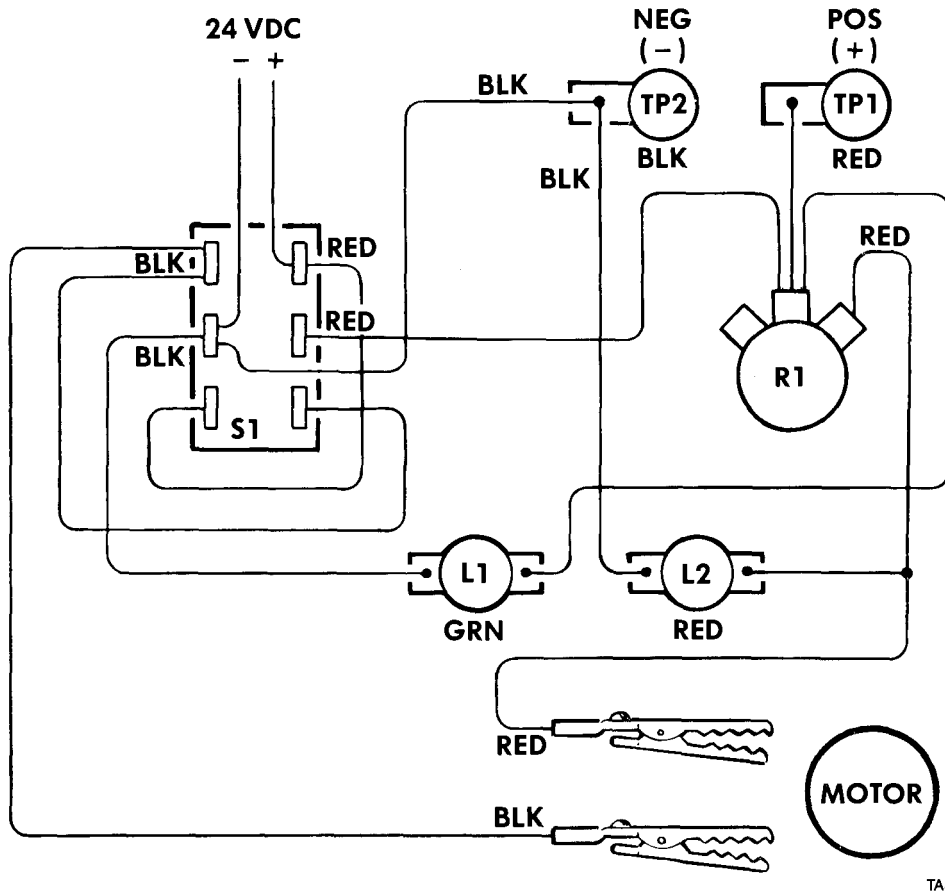

TA356321

Figure 2-8. 12V Electric Motor Tester Circuit Wiring Diagram (M983).

Troubleshooting Malfunctions (Cont)

2-7. TROUBLESHOOTING INSTRUCTIONS (CONT).

Table 2-3. Troubleshooting (Cont)

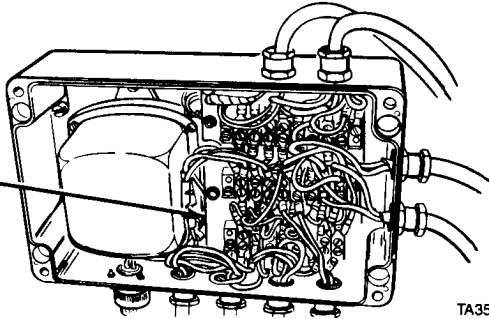
Malfunction	Test or Inspection	Corrective Action
MATERIAL HANDLING CRANE (M983) (CONT)		
26. ONE FUNCTION ROD RETURNS TO NEUTRAL, BUT DOES NOT RESPOND TO CONTROLLER.		
	NOTE	
	Remote controller requires 24 vdc to operate properly.	
	Step 1. Remove fuse cover (para 18-35). Check for blown fuse.	
	Replace blown fuse (para 18-35).	
	Step 2. Remove tilt warning box cover (para 6-7). Set multimeter to test for 18 to 30 vdc. Check TB1-5 for 24 vdc with remote controller power on and engine running (fig. 2-8).	
	If voltage is low, service batteries (TM 9-6140-200-14).	
	Step 3. Test for enable signal to electronic module (para 18-36).	
	If harness does not pass test, repair harness (para 18-35).	
	Step 4. Set multimeter to X1K. Check remote controller cable for damage and continuity.	
	Repair defective remote controller cable.	
	CRANE CONTROL DISTRIBUTION BOARD	
		
	TA356323	
	Step 5. Check connectors and wires on crane control distribution board for damage and loose connections (fig. 2-7).	
	Repair wires and tighten connectors (para 6-8).	

Troubleshooting Malfunctions (Cont)
 Table 2-3. Troubleshooting (Cont)

Malfunction
Test or Inspection
Corrective Action

MATERIAL HANDLING CRANE (M983) (CONT)

26. ONE FUNCTION ROD RETURNS TO NEUTRAL, BUT DOES NOT RESPOND TO CONTROLLER (CONT).

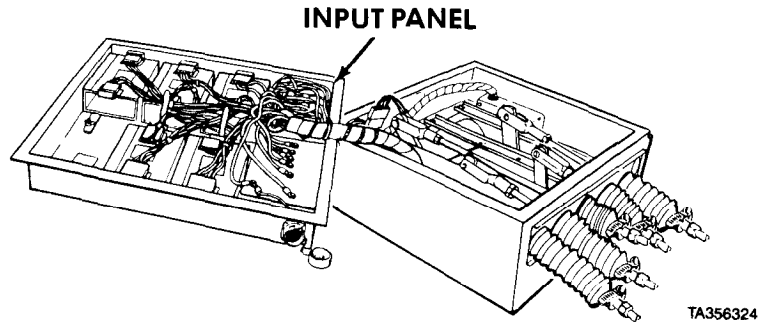

Step 6. Check input panel for visible signs of electrical or mechanical damage.
 Replace defective input panel (para 18-35).

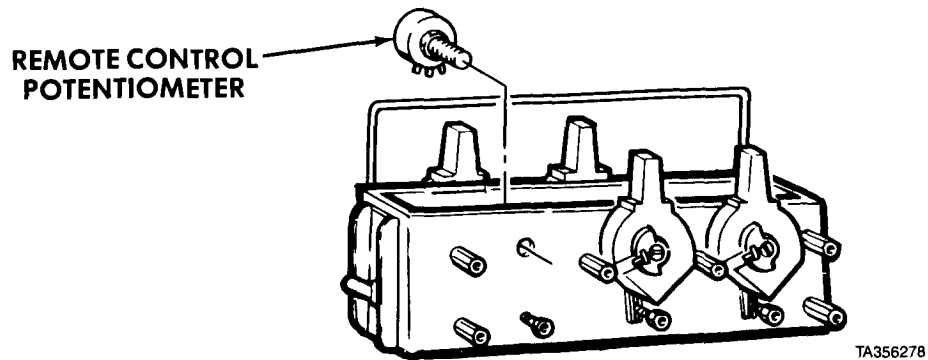

Step 7. Set multimeter to X1K. Check remote controller potentiometers for damage and continuity.
 Replace defective remote controller potentiometers (para 18-43).

Step 8. Check if remote controller potentiometers are out of adjustment (para 18-45).
 Adjust remote control potentiometers (para 18-45).

Troubleshooting Malfunctions (Cont)

2-7. TROUBLESHOOTING INSTRUCTIONS (CONT).

Table 2-3. Troubleshooting (Cont)

Malfunction	Test or Inspection	Corrective Action
MATERIAL HANDLING CRANE (M983) (CONT)		
26.	ONE FUNCTION ROD RETURNS TO NEUTRAL, BUT DOES NOT RESPOND TO CONTROLLER (CONT).	<div data-bbox="342 629 1295 1293"> <p data-bbox="1060 736 1295 821">ELECTRIC MOTOR PROPORTIONAL CONTROLLER</p> </div> <p data-bbox="1206 1272 1286 1293">TA356277</p> <p data-bbox="215 1330 1384 1391">Step 9. Set multimeter to X1K. Check electric motor proportional controllers for damage and continuity.</p> <p data-bbox="438 1406 1315 1440">Replace defective electric motor proportional controllers (para 18-35).</p> <p data-bbox="215 1457 1367 1493">Step 10. Check if electric motor proportional controllers are out of adjustment (para 18-37).</p> <p data-bbox="438 1502 1228 1536">Adjust motor proportional control potentiometers (para 18-37).</p>

Troubleshooting Malfunctions (Cont)
 Table 2-3. Troubleshooting (Cont)

Malfunction	Test or Inspection	Corrective Action
-------------	--------------------	-------------------

MATERIAL HANDLING CRANE (M983) (CONT)

27. CRANE OPERATION NOT SMOOTH IN REMOTE CONTROL MODE.

NOTE

Remote controller requires 24 vdc to operate properly. If battery voltage is less than 24 vdc, service batteries (TM 9-6140-200-14).

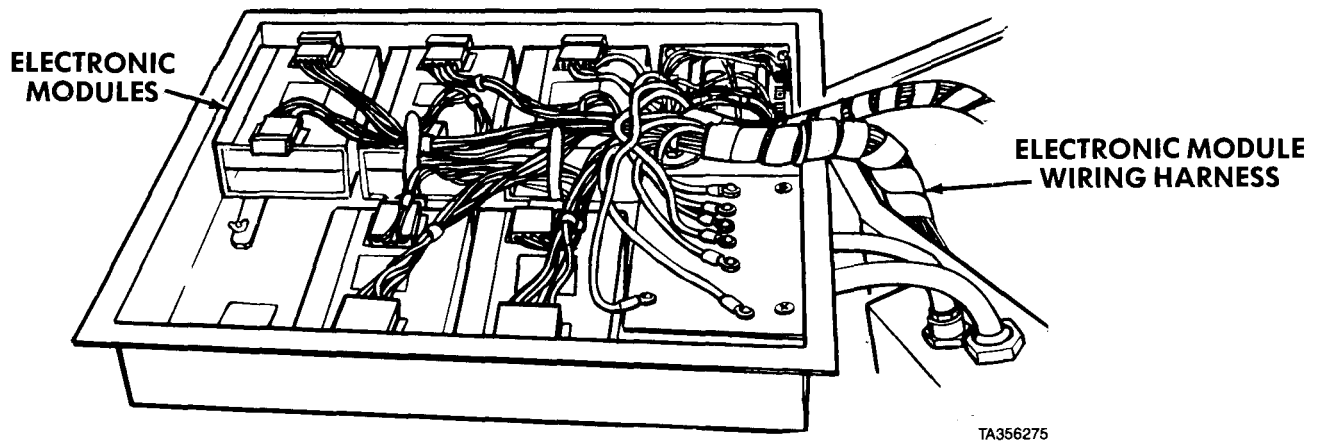

Step 1. Test electronic module (para 18-36).

Replace defective electronic module (para 18-35).

Step 2. Check electronic module wiring harness for broken wires and loose connections.

Repair broken wires and tighten loose connections (para 18-35).

Troubleshooting Malfunctions (Cont)

2-7. TROUBLESHOOTING INSTRUCTIONS (CONT).

Table 2-3. Troubleshooting (Cont)

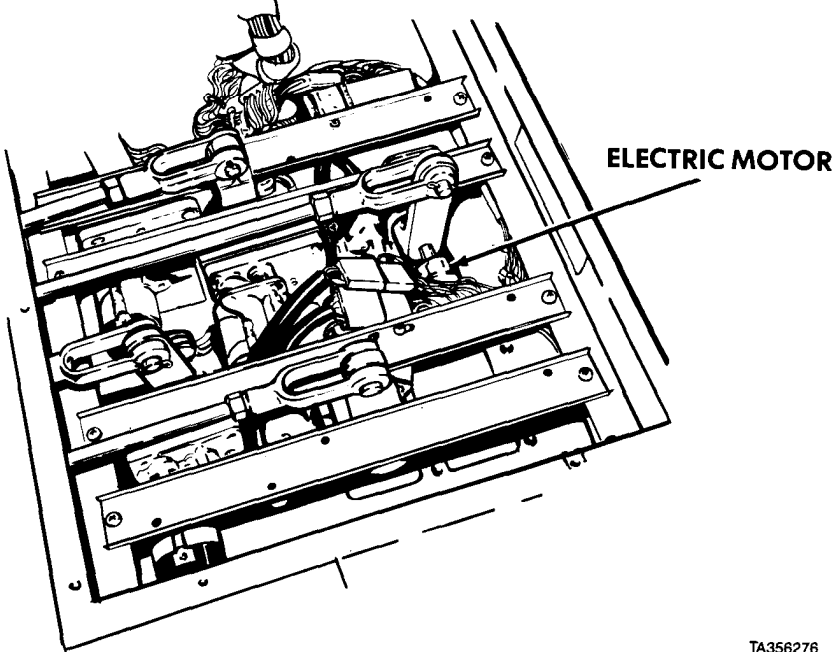
Malfunction	Test or Inspection	Corrective Action
MATERIAL HANDLING CRANE (M983) (CONT)		
27. CRANE OPERATION NOT SMOOTH IN REMOTE CONTROL MODE (CONT).		
		
TA356276		
<p>Step 3. Set multimeter to X1K. Check electric motor for loose or broken wires and continuity. Repair loose or broken wires or replace defective electric motor and gearcase (para 18-35).</p>		
<p>Step 4. Check electric motor gearcase for noisy gears, indicating worn or damaged gears. Replace defective motor and gearcase (para 18-35).</p>		

Troubleshooting Malfunctions (Cont)
 Table 2-3. Troubleshooting (Cont)

Malfunction	Test or Inspection	Corrective Action
-------------	--------------------	-------------------

MATERIAL HANDLING CRANE (M983) (CONT)

27. CRANE OPERATION NOT SMOOTH IN REMOTE CONTROL MODE (CONT).

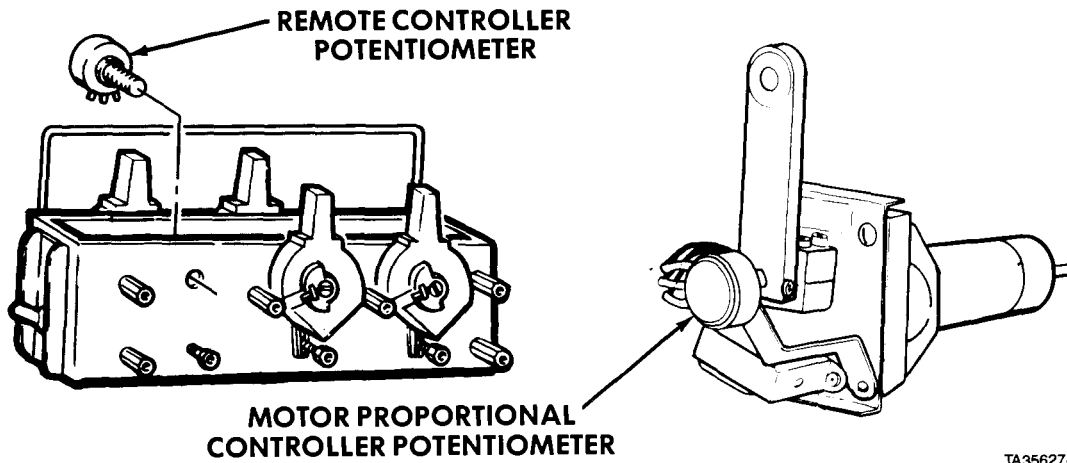

TA356274

Step 5. Check if remote controller potentiometer is out of adjustment (para 18-45).

Adjust remote controller potentiometer (para 18-45).

Step 6. Check motor proportional controller potentiometer (para 18-35) for approximately 530 ohms.

Adjust motor proportional controller potentiometer (para 18-37) or replace potentiometer (para 18-35).

28. CONTROL RODS DO NOT MOVE COMPLETELY IN OR OUT.

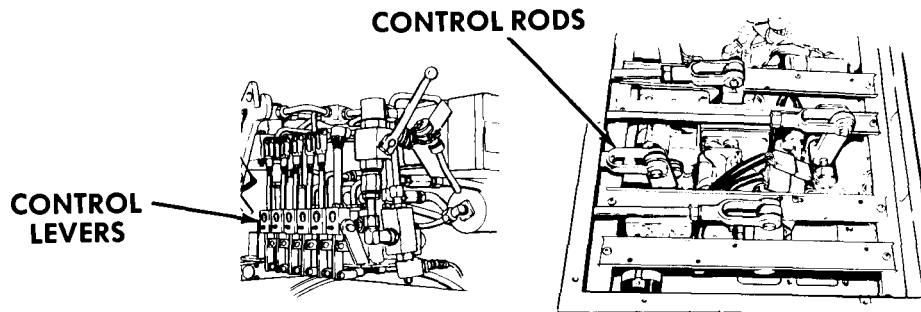

TA356326

NOTE

Remote controller requires 24 vdc to operate properly. If battery voltage is less than 24 vdc, service batteries (TM 9-6140-200-14).

Step 1. Check control levers and rods for loose or stiff linkages.

Repair loose or stiff control lever and rod linkages (paras 18-35 and 18-41).

Troubleshooting Malfunctions (Cont)

2-7. TROUBLESHOOTING INSTRUCTIONS (CONT).

Table 2-3. Troubleshooting (Cont)

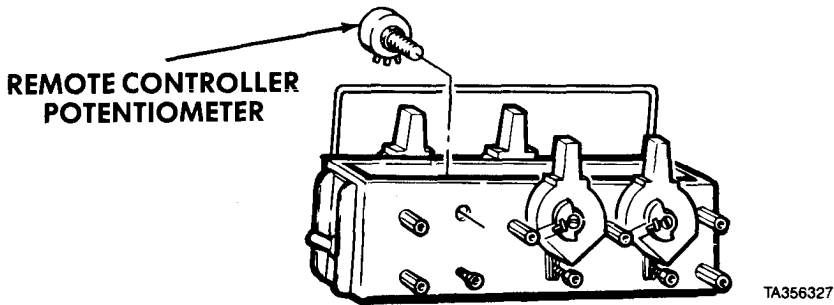
Malfunction	Test or Inspection	Corrective Action
MATERIAL HANDLING CRANE (M983) (CONT)		
28. CONTROL RODS DO NOT MOVE COMPLETELY IN OR OUT (CONT).		
		
<p>Step 2. Check if remote controller potentiometers are out of adjustment (para 18-45). Adjust remote controller potentiometers (para 18-45).</p>		
<p>Step 3. Check electric motor gearcase (para 18-35) for noisy gears, indicating worn or damaged parts. Replace defective motor and gearcase (para 18-35).</p>		

Troubleshooting Malfunctions (Cont)
 Table 2-3. Troubleshooting (Cont)

Malfunction	Test or Inspection	Corrective Action
-------------	--------------------	-------------------

MATERIAL HANDLING CRANE (M983) (CONT)

29. CRANE WILL NOT RAISE OR EXTEND IN REMOTE OPERATION, BUT WILL LOWER AND RETRACT, AND SWING WORKS IN BOTH DIRECTIONS (OVERLOAD PROTECTION CIRCUIT MALFUNCTION).

NOTE

- Remote controller requires 24 vdc to operate properly. If battery voltage is less than 24 vdc, service batteries (TM 9-6140-200-14).
- A malfunction in the electrical overload protection system does not affect manual hydraulic operation of the M983 crane. The electrical overload protection system functions only when crane is set up for remote control operation.

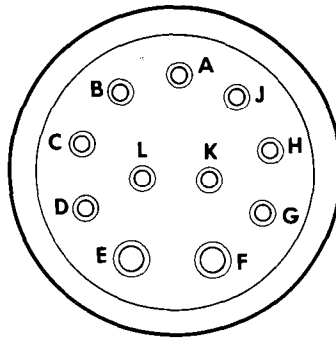

POWER DISTRIBUTION CABLE CONNECTOR

TA356273

Step 1. Check for 24 vdc power to crane control box. Set multimeter to test for 18 to 30 vdc. Remove power distribution cable from crane control box. Set ENGINE, PTO ENGAGE, and remote control power switches to ON. Place multimeter positive (+) probe in cable connector socket J and touch negative (-) probe to crane control box.

If there is 24 vdc, go to step 2.

If no voltage, go to step 3.

2-7. TROUBLESHOOTING INSTRUCTIONS (CONT).

Table 2-3. Troubleshooting (Cont)

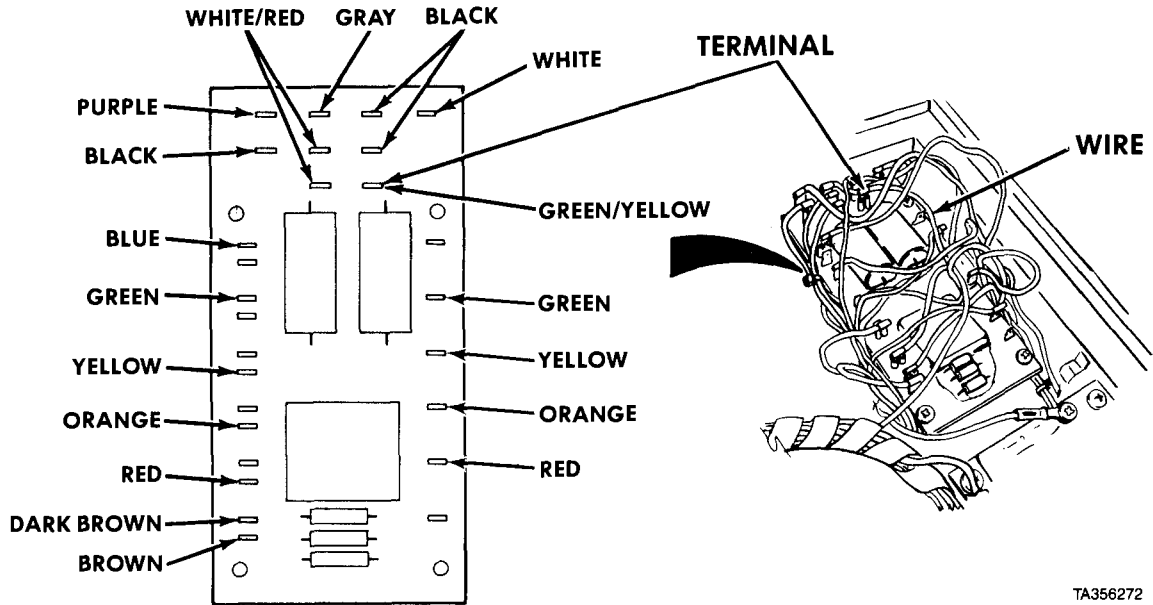
Malfunction	Test or Inspection	Corrective Action
MATERIAL HANDLING CRANE (M983) (CONT)		
29.	CRANE WILL NOT RAISE OR EXTEND IN REMOTE OPERATION, BUT WILL LOWER AND RETRACT, AND SWING WORKS IN BOTH DIRECTIONS (OVERLOAD PROTECTION CIRCUIT MALFUNCTION) (CONT).	
		<p>Step 2. Check for defective power wire and input circuit board. Remove crane control box cover. Set multimeter to test for 18 to 30 vdc. Set ENGINE, PTO ENGAGE, and remote control power switches to ON. Place multimeter positive (+) probe on input board terminal and touch negative (-) probe to crane control box.</p> <p style="padding-left: 40px;">If there is no power, check wire for defects, repair or replace wire, then go to step 3.</p> <p style="padding-left: 40px;">If there is 24 vdc, replace input board (para 18-35).</p>
NOTE		
<p>Each wire in power distribution cable must be removed from terminal board connection before making resistance check.</p>		
Step 3.	<p>Check for defective power distribution cable. Set multimeter to X1K. Remove tilt warning box cover. Test for zero ohms resistance on all five wires from terminal board connection to cable connector (fig. 2-6).</p>	<p>If resistance is more than zero ohms, repair defective wire or replace power distribution cable (para 18-35).</p>

TA356272

Troubleshooting Malfunctions (Cont)
 Table 2-3. Troubleshooting (Cont)

Malfunction	Test or Inspection	Corrective Action
MATERIAL HANDLING CRANE (M983) (CONT)		
29. CRANE WILL NOT RAISE OR EXTEND IN REMOTE OPERATION, BUT WILL LOWER AND RETRACT, AND SWING WORKS IN BOTH DIRECTIONS (OVERLOAD PROTECTION CIRCUIT MALFUNCTION) (CONT).		
	Step 4. Check for defective overload protection circuit wiring. Set multimeter to X1K. Remove tilt warning alarm switch (para 18-35). Test for zero ohms between TB1-6 and overload protection circuit board socket No. 1 (fig. 2-6).	If resistance is more than zero ohms, replace wire.
	Step 5. Check for defective overload protection circuit wiring. Set multimeter to X1K. Remove tilt warning alarm switch (para 18-35). Test for zero ohms between TB1-6 and overload protection circuit board socket No. 2 (fig. 2-6).	If resistance is more than zero ohms, replace wire.
	Step 6. Check overload protection circuit board for defects. Remove power distribution board (para 6-8). Check circuit board for cracks and loose components.	If board is okay, install circuit board and power distribution board, then go to step 7. If board is cracked or has loose components, replace board (para 6-8).
	Step 7. Check for 24 vdc power to overload protection circuit board. Set multimeter to test for 18 to 30 vdc. Set ENGINE, PTO ENGAGE, and remote controller power switches to ON. Test for 24 vdc between TB1-5 and overload protection circuit board socket No. 5 (fig. 2-6).	If no voltage, replace wire.
	Step 8. Check for 24 vdc power on overload protection circuit board between sockets No. 2 and No. 5 (fig. 2-6).	If no voltage, replace circuit board (para 6-8).

Troubleshooting Malfunctions (Cont)

2-7. TROUBLESHOOTING INSTRUCTIONS (CONT).

Table 2-3. Troubleshooting (Cont)

Malfunction	Test or Inspection	Corrective Action
MATERIAL HANDLING CRANE (M983) (CONT)		
<p>29. CRANE WILL NOT RAISE OR EXTEND IN REMOTE OPERATION, BUT WILL LOWER AND RETRACT, AND SWING WORKS IN BOTH DIRECTIONS (OVERLOAD PROTECTION CIRCUIT MALFUNCTION) (CONT).</p>		
	NOTE	
	<p>Connector face has letters stamped for pin placement.</p>	
	<p>Step 9. Check resistance between input board and pin J on crane control box connector.</p>	
	<p>If resistance is zero ohms, go to step 12.</p>	
	<p>If resistance is more than zero ohms, go to step 10.</p>	

TA356271

Troubleshooting Malfunctions (Cont)
 Table 2-3. Troubleshooting (Cont)

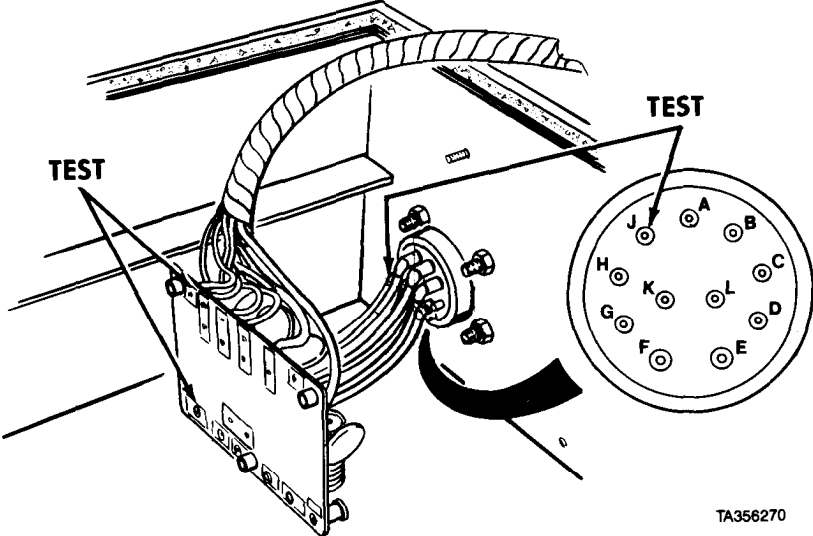
Malfunction	Test or Inspection	Corrective Action
MATERIAL HANDLING CRANE (M983) (CONT)		
29.	CRANE WILL NOT RAISE OR EXTEND IN REMOTE OPERATION, BUT WILL LOWER AND RETRACT, AND SWING WORKS IN BOTH DIRECTIONS (OVERLOAD PROTECTION CIRCUIT MALFUNCTION) (CONT).	
		
<p>Step 10. Check resistance between pin J on crane control box connector and filter circuit board. Remove filter circuit board cover (para 18-35).</p> <p style="padding-left: 40px;">If resistance is zero ohms, go to step 11.</p> <p style="padding-left: 40px;">If resistance is more than zero ohms, replace wire.</p> <p>Step 11. Check resistance across filter circuit board terminals.</p> <p style="padding-left: 40px;">If resistance is zero ohms, go to step 12.</p> <p style="padding-left: 40px;">If resistance is more than zero ohms, replace filter circuit board (para 18-35).</p>		

Troubleshooting Malfunctions (Cont)

2-7. TROUBLESHOOTING INSTRUCTIONS (CONT).

Table 2-3. Troubleshooting (Cont)

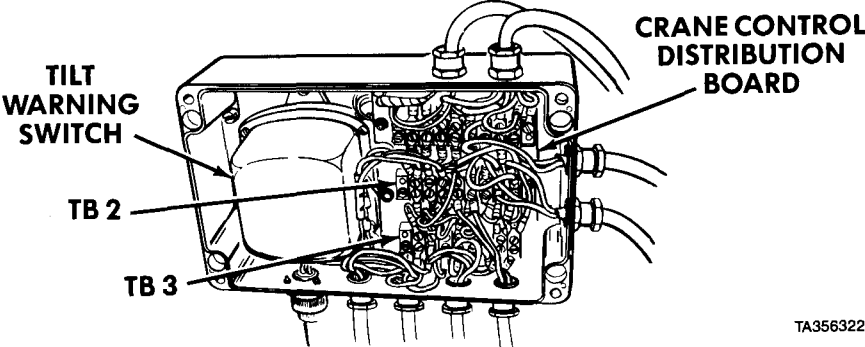
Malfunction	Test or Inspection	Corrective Action
MATERIAL HANDLING CRANE (M983) (CONT)		
30. NO VISUAL OR AUDIBLE TILT ALARMS.		
 <p>The diagram shows a rectangular metal enclosure for the crane control distribution board. On the left side, there is a 'TILT WARNING SWITCH' with a label pointing to it. Below the switch are two terminal blocks labeled 'TB 2' and 'TB 3'. On the right side, there is a 'CRANE CONTROL DISTRIBUTION BOARD' with a label pointing to it. The board is densely packed with wires and components. At the bottom of the enclosure, there are several screw terminals. The diagram is labeled 'TA356322' in the bottom right corner.</p>		
<p>Step 1. Set multimeter to test for 24 vdc. Set ENGINE, PTO ENGAGE, and crane remote control power switches to ON. Check for 24 vdc power from TB2-B3 to TB2-B2 (fig. 2-6).</p>		
<p style="padding-left: 40px;">If there is no power, repair or replace wire from TB3-A3 to TB3-B3.</p>		
<p>Step 2. Set multimeter to X1K. Check crane control distribution board for continuity across TB2-B1 and TB2-B2 (fig. 2-6) to check out tilt warning switch. Remove tilt warning switch from tilt warning box (para 6-7) but do not disconnect wires. Tilt switch from side to side while checking continuity.</p>		
<p style="padding-left: 40px;">Replace defective tilt warning switch (para 6-7).</p>		
<p>Step 3. Remove distribution circuit board and crane control distribution board (para 6-8) but leave wires connected. Check for visible electrical damage or other damage to board.</p>		
<p style="padding-left: 40px;">Replace defective tilt warning circuit board (para 6-8).</p>		
<p>Step 4. Set multimeter to X1K. Check tilt warning sensor cable for continuity. Remove tilt warning box cover (para 6-7). Check continuity across TB3-B1 and TB3-B2 (fig. 2-6).</p>		
<p style="padding-left: 40px;">If no continuity, remove tilt warning sensor cable (para 6-10) and repair.</p>		

Troubleshooting Malfunctions (Cont)
 Table 2-3. Troubleshooting (Cont)

Malfunction	Test or Inspection	Corrective Action
-------------	--------------------	-------------------

MATERIAL HANDLING CRANE (M983) (CONT)

31. CRANE OUTRIGGER EXTENDED LIGHT DOES NOT WORK.

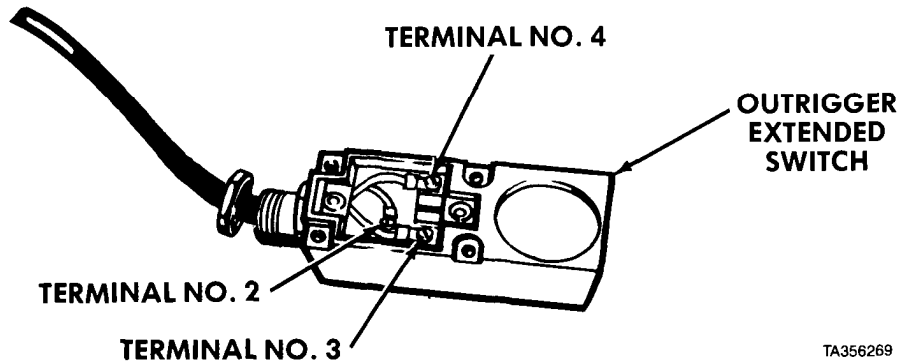

- Step 1. Set multimeter to X1K. Check outrigger extended switch wiring for damage, no continuity, and loose connection (FO-2).
 Repair switch wiring (FO-2).
- Step 2. Check outrigger extended switch for continuity between terminal No. 4 and terminal No. 3, and between terminal No. 4 and terminal No. 2.
 If there is no continuity, replace defective outrigger extended switch (para 6-6).
- Step 3. Check outrigger cables for continuity between switch terminals and tilt warning distribution board using chart below.
 If cable is bad, remove (para 6-9) and repair.

SWITCH TERMINAL	to	TB2
2 (-)		4
3 (-)		8
4 (+)		6 (RIGHT) 7 (LEFT)

Troubleshooting Malfunctions (Cont)

2-7. TROUBLESHOOTING INSTRUCTIONS (CONT).

Table 2-3. Troubleshooting (Cont)

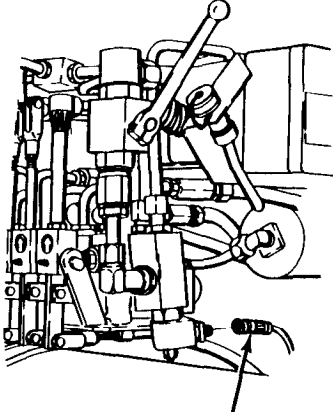
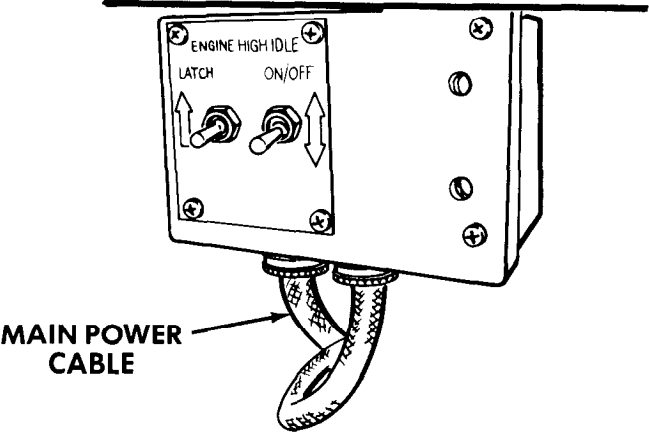
Malfunction Test or Inspection	Corrective Action
MATERIAL HANDLING CRANE (M983) (CONT)	
32. REMOTE CONTROLLER OPERATING, BUT CRANE WILL NOT MOVE.	
	
DUMP VALVE HARNESS	MAIN POWER CABLE
TA356268	
<p>Step 1. Check for defective dump valve solenoid. Set up remote control panel (TM 9-2320-279-10). Turn ENGINE switch ON. Do not turn ENGINE switch to START.</p> <p>Disconnect dump valve solenoid harness. Set multimeter to test for 18 to 30 vdc. Check dump valve harness for 24 vdc at socket B.</p> <p style="padding-left: 40px;">If there is power, replace dump valve solenoid (para 18-16).</p> <p>Step 2. Disconnect main power cable. Check cable for continuity.</p> <p style="padding-left: 40px;">Repair defective main power cable (para 6-9).</p> <p>Step 3. Set multimeter to X1K. Check remote controller cable for damage and continuity.</p> <p style="padding-left: 40px;">Repair remote controller cable (para 18-44).</p>	

Troubleshooting Malfunctions (Cont)
 Table 2-3. Troubleshooting (Cont)

Malfunction Test or Inspection	Corrective Action
-----------------------------------	-------------------

MATERIAL HANDLING CRANE (M983) (CONT)

32. REMOTE CONTROLLER OPERATING, BUT CRANE WILL NOT MOVE (CONT).

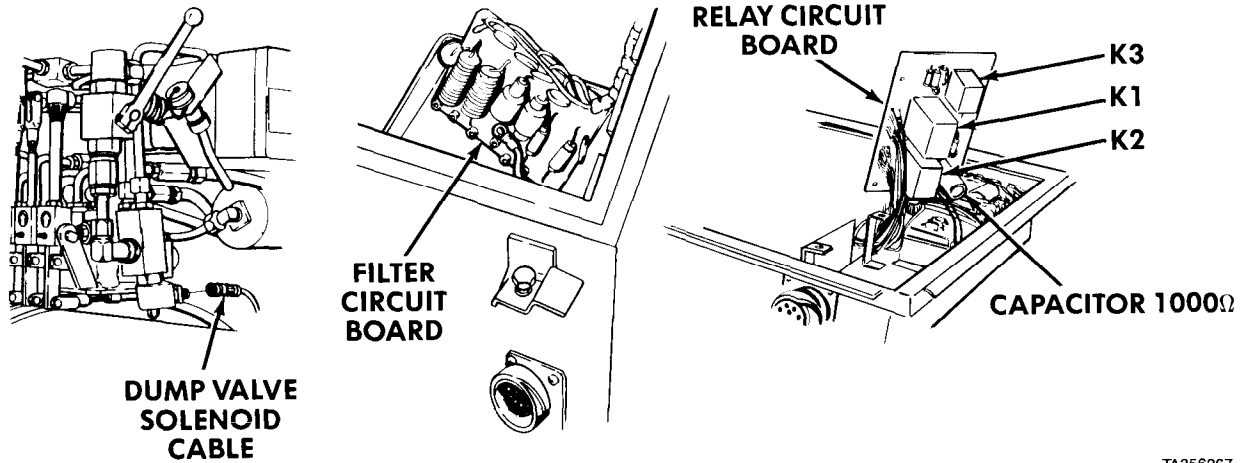

TA356267

- Step 4. Check dump valve solenoid cable from pin B to filter circuit board for continuity.
 Repair defective dump valve solenoid cable (para 6-9).
- Step 5. Check filter circuit board for continuity across all filters.
 Replace defective filter circuit board (para 18-35).
- Step 6. Check that relay circuit board relay K1 closes when 24 vdc is applied to pin B on connector.
 Replace defective relay circuit board (para 18-35).

Troubleshooting Malfunctions (Cont)

2-7. TROUBLESHOOTING INSTRUCTIONS (CONT).

Table 2-3. Troubleshooting (Cont)

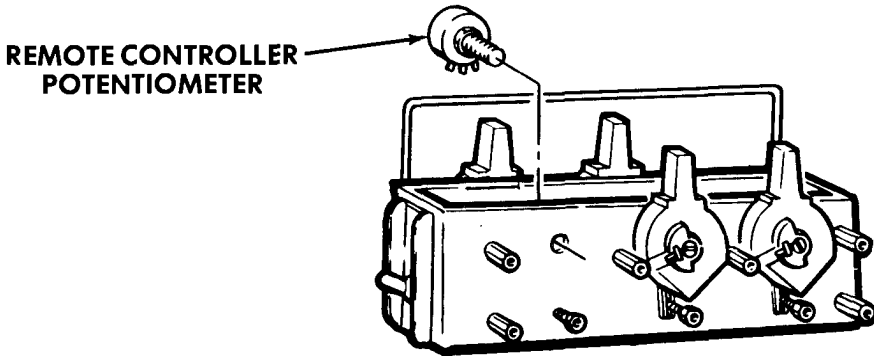
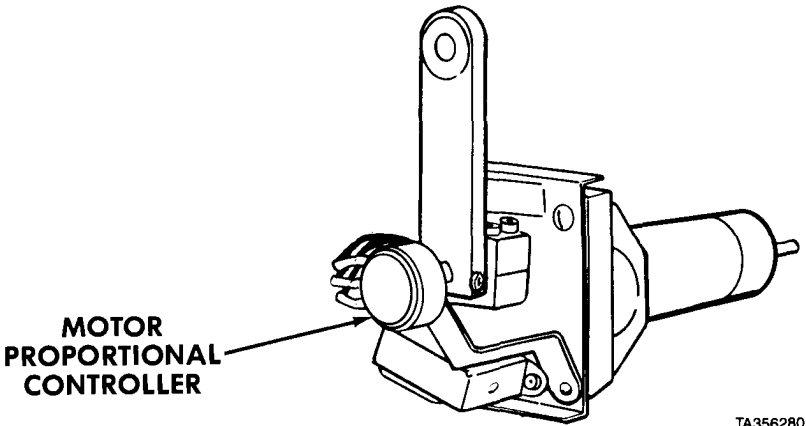
Malfunction	Test or Inspection	Corrective Action
MATERIAL HANDLING CRANE (M983) (CONT)		
33. CRANE STARTS TO MOVE AS SOON AS REMOTE CONTROLLER IS CONNECTED AND TURNED ON.	 <p style="text-align: right;">TA356279</p>	<p>Step 1. Check if remote controller potentiometer is out of adjustment (para 18-43). Adjust remote controller potentiometer (para 18-45).</p>
	 <p style="text-align: right;">TA356280</p>	<p>Step 2. Check if motor proportional control potentiometers are out of adjustment (para 18-37). Adjust motor proportional control potentiometers (para 18-37).</p> <p>Step 3. If problem remains, replace electronic motor (para 18-35).</p>

Troubleshooting Malfunctions (Cont)

Table 2-3. Troubleshooting (Cont)

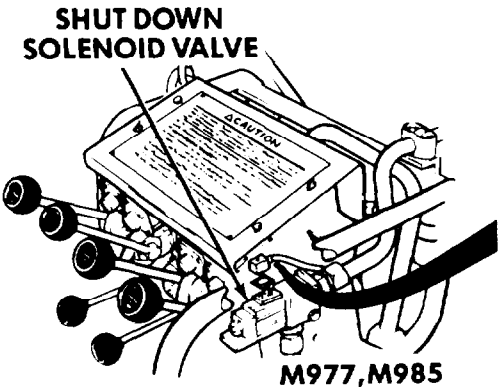
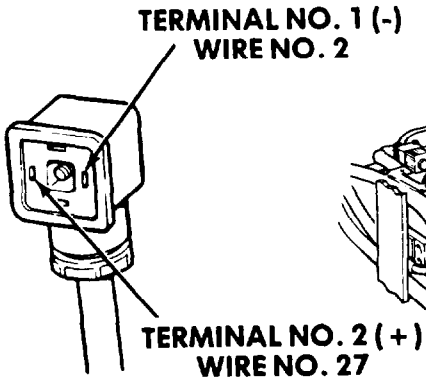
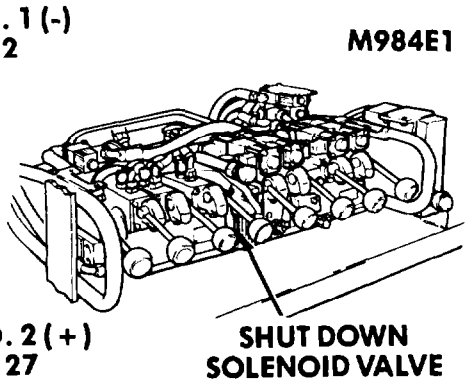
Malfunction	Test or Inspection	Corrective Action
MATERIAL HANDLING CRANE (M977, M985, M984E1)		
<u>WARNING</u>		
<p>Always support crane when disconnecting lines from cylinders when crane is not in transport position. Check valves may be bad and allow crane to fall, causing injury or death to personnel.</p>		
NOTE		
<ul style="list-style-type: none"> • A common cause of crane malfunction is contaminated oil. Seals and packings frequently break down in very hard use, and the small pieces of seals and packings can travel through hydraulic lines into control valves, slowing or completely blocking oil flow. • When troubleshooting the M977, M985, and M984E1 material handling cranes, refer to foldout sheets, 3, 4, and 5 of Hydraulic Schematics, Wiring Diagrams, and Crane Electrical Schematics. • M977 material handling crane is usually illustrated in this section. Location of valves on cylinders, swing and hoist systems is very similar on M977, M985, and M984E1 material handling cranes. Only important differences are illustrated. 		
<p>1. CRANE WILL NOT OPERATE MANUALLY OR WITH REMOTE CONTROL.</p>		
<p>Step 1. (M984E1) Operate retrieval system (TM 9-2320-279-10).</p>		
<p>If retrieval system works, (the pump, relief valve and oil filter are good), repair crane controls (para 17-28.2 or 17-28.3).</p>		
<p>If retrieval system does not work, go to Step 2.</p>		
		

Troubleshooting Malfunctions (Cont)

2-7. TROUBLESHOOTING INSTRUCTIONS (CONT).

Table 2-3. Troubleshooting (Cont)

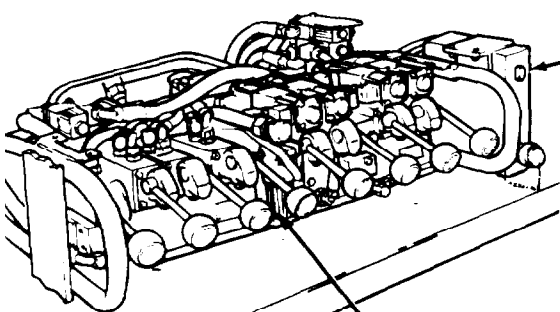
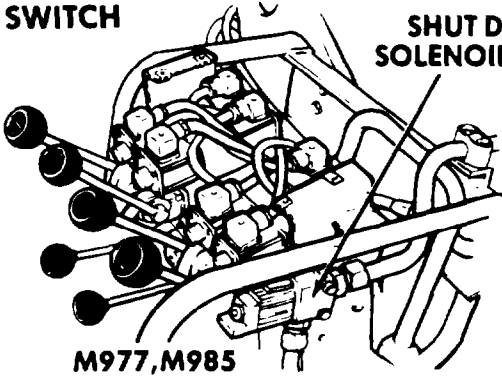
Malfunction	Test or Inspection	Corrective Action
MATERIAL HANDLING CRANE (M977, M985, M984E1) (CONT)		
1. CRANE WILL NOT OPERATE MANUALLY OR WITH REMOTE CONTROL (CONT).		
 <p data-bbox="147 995 257 1023">M984E1</p> <p data-bbox="480 974 719 1034">SHUT DOWN SOLENOID VALVE</p>	 <p data-bbox="707 661 942 689">POWER SWITCH</p> <p data-bbox="1194 672 1433 732">SHUT DOWN SOLENOID VALVE</p> <p data-bbox="887 1006 1055 1034">M977, M985</p>	TA477000
<p>Step 2. Check that shut-down solenoid valve operates. Set ENGINE and PTO ENGAGE switches to ON. Move crane POWER switch ON and OFF several times. Listen for clicking sound of solenoid to tell if solenoid operates.</p>		
<p style="padding-left: 40px;">If solenoid clicks but crane will not operate, try to operate crane using emergency procedures (TM 9-2320-279-10).</p>		
<p style="padding-left: 40px;">If crane operates, replace defective shut-down solenoid valve (para 17-32 for M977 and M985), (para 17-32.1 for 11984E1).</p>		
<p style="padding-left: 40px;">If crane does not operate (M977 and M985). refer to Hydraulic System Troubleshooting.</p>		
<p style="padding-left: 40px;">If crane does not operate (M984E1). refer to Step 4.</p>		

Troubleshooting Malfunctions (Cont)

Table 2-3. Troubleshooting (Cont)

Malfunction	Test or Inspection	Corrective Action
-------------	--------------------	-------------------

MATERIAL HANDLING CRANE (M977, M985, M984E1) (CONT)

1. CRANE WILL NOT OPERATE MANUALLY OR WITH REMOTE CONTROL (CONT).

Step 3. Check for defective cable module. Remove power cable connector from shut-down solenoid valve. Set ENGINE, PTO ENGAGE, and crane POWER switches to ON. Check for 24 to 30 vdc at connector terminals.

If 24 to 30 vdc is not available at terminal No. 2, replace cable module (para 6-11 for M977 and M985), (para 6-11.1 for M984E1).

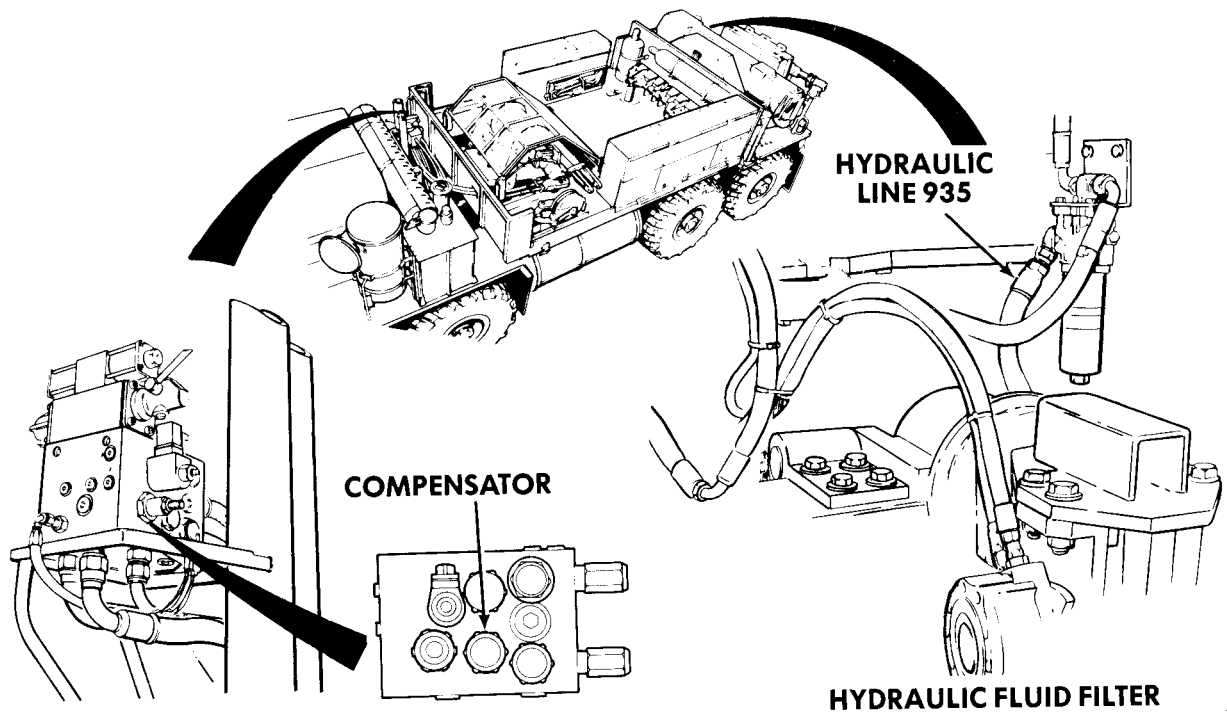

Step 4. (M984E1 only) Remove hydraulic line 935 from hydraulic filter and install flowmeter. Start engine, engage PTO, set high idle (TM 9-2320-279-10). Operate load valve on flowmeter until 3000 psi (20 685 kPa) is obtained.

If 10 GPM (38 liters/min) (minimum) at 3000 psi (20 685 kPa) is obtained, repair crane valve bank (para 17-28.3 or 17-28.4).

If 10 GPM (38 liters/min) (minimum) at 3000 psi (20 685 kPa) is not obtained, refer to Hydraulic System Troubleshooting. If Hydraulic System Troubleshooting does not solve problem, replace compensator.

2-7. TROUBLESHOOTING INSTRUCTIONS (CONT).

Table 2-3. Troubleshooting (Cont)

Malfunction	Test or Inspection	Corrective Action
MATERIAL HANDLING CRANE (M977, M985, M984E1) (CONT)		
2. OUTRIGGER OPERATION SLOW OR ERRATIC.		
Step 1. Refer to HYDRAULIC SYSTEM troubleshooting.		
If outrigger operation is still slow or erratic, go to Step 2. Check outrigger for lubrication, serviceability.		
Step 2. Check for damaged outrigger lines.		
Replace damaged outrigger lines (para 17-39 for M977 and M985), (para 17-38.1 for M984E1).		
Step 3. Check main hydraulic pressure adjustment (para 17-31 for M977 and M985), (para 17-31.1 for M984E1).		
If pressure cannot be adjusted, repair crane controls (para 17-28 for M977 and M985), (paras 17-28.2 and 17-28.3 for M984E1).		
Step 4. Check for contaminated or damaged outrigger beam control valve.		
Remove, clean, inspect, and install outrigger beam control valve (para 17-28 for M977 and M985). On M984E1, left outrigger beam control valve is in para 17-28.2 and right outrigger beam control valve is in para 17-28.3.		
Step 5. Check for contaminated or damaged right and left outrigger control valves.		
Remove, clean, inspect, and install right and left outrigger control valves (para 17-28 for M977 and M985), (paras 17-28.2 and 17-28.3 for M984E1).		

Troubleshooting Malfunctions (Cont)

Table 2-3. Troubleshooting (Cont)

Malfunction	Test or Inspection	Corrective Action
MATERIAL HANDLING CRANE (M977, M985, M984E1) (CONT)		
2. OUTRIGGER OPERATION SLOW OR ERRATIC (CONT).		
Step 6. Check for contaminated or damaged main relief valve.		Remove, clean, inspect, and install main relief valve (para 17-28 for M977 and M985), (paras 17-28.2 and 17-28.3 for M984E1).
Step 7. (M984E1). Check for contaminated or damaged outrigger extension cylinder double shuttle valves.		Remove, clean, inspect, and install outrigger extension cylinder double shuttle valves (para 17-28.2).
Step 8. Check for damaged outrigger extension cylinder.		Replace cylinder (para 17-39 for M977 and M985), (paras 17-38.1 and 17-39.1 for M984E1).
Step 9. Check for damaged outrigger leg cylinder.		Replace cylinder (para 17-36 for M977 and M985), (para 17-36.1 for M984E1).
3. OUTRIGGER BEAM WILL NOT EXTEND OR RETRACT.		
Step 1. Refer to HYDRAULIC SYSTEM troubleshooting.		If problem remains, go to step 2.
Step 2. Check for damaged extension cylinder lines.		Replace damaged extension cylinder lines (para 17-38 for M977 and M985), (paras 17-38.1 and 17-39.1 for M984E1).
Step 3. Check main hydraulic pressure adjustment (para 17-31 for M977 and M985), (para 17-31.1 for M984E1).		Repair defective crane controls (para 17-28 for M977 and M985), (paras 17-28.2 and 17-28.3 for M984E1).
Step 4. (M984E1). Check for contaminated or damaged double counterbalance valves.		Remove, clean, inspect, and install double counterbalance valves (para 17-41).
Step 5. Check for contaminated outrigger directional control valve spools.		Remove, disassemble, clean, inspect, assemble, and install directional control valve spool (para 17-28 for M977 and M985), (paras 17-28.2 and 17-28.3 for M984E1).
Step 6. Check for contaminated or damaged outrigger extension cylinder.		Replace cylinder (para 17-39 for M977 and M985), (paras 17-38.1 and 17-39.1 for M984E1).

2-7. TROUBLESHOOTING INSTRUCTIONS (CONT).

Table 2-3. Troubleshooting (Cont)

Malfunction Test or Inspection	Corrective Action
MATERIAL HANDLING CRANE (M977, M985, M984E1) (CONT)	
4. OUTRIGGER LEG (LEFT OR RIGHT) WILL NOT SUPPORT LOAD OR EXTEND AND RETRACT.	<div data-bbox="475 649 1296 1064" style="text-align: center;"> <p>The diagram consists of two parts. On the left is a detailed view of an 'OUTRIGGER LEG HOLDING VALVE', which is a cylindrical component with a threaded top and a bottom fitting. A line points from the text label to this valve. On the right is a side-view schematic of the crane's chassis, labeled 'M977', showing the four outrigger legs extending from the base. A curved arrow indicates the movement of one of the legs.</p> </div> <p style="text-align: right; margin-right: 50px;">TA476856</p> <p style="text-align: center;"><u>WARNING</u></p> <p>Remove any load from outriggers before loosening holding valve. Vehicle can tip, and load will drop, causing injury or death to personnel.</p> <p>Step 1. Check for damaged outrigger leg cylinder lines. Replace damaged outrigger leg cylinder lines (para 17-2 for M977 and M985), (para 17-2.1 for M984E1).</p> <p>Step 2. Check for damaged outrigger leg cylinder. Remove cylinder (para 17-36 for M977 and M985), (para 17-36.1 for M984E1).</p> <p>Step 3. Check for contaminated or damaged holding valve. Remove, clean, inspect, and install holding valve (para 17-37 for M977 and M985), (para 17-37.1 for M984E1). Do not remove outrigger leg cylinder.</p> <p>Step 4. Check for contaminated or damaged directional control spool valve. Remove retract line from cylinder (para 17-2 for M977 and M985), (para 17-2.1 for M984E1). Operate crane (TM 9-2320-279-10). Do not touch O/R JACK controls. If oil flows from retract line, shut down crane (TM 9-2320-279-10). Remove, clean, inspect, and install directional control valve spool (para 17-28 for M977 and M985), (para 17-28.2 and 17-28.3 for M984E1).</p>

Troubleshooting Malfunctions (Cont)

Table 2-3. Troubleshooting (Cont)

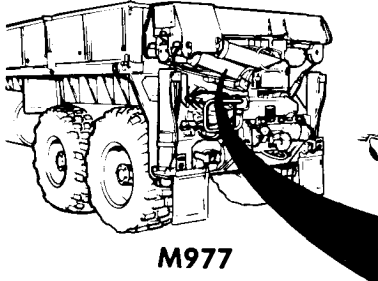
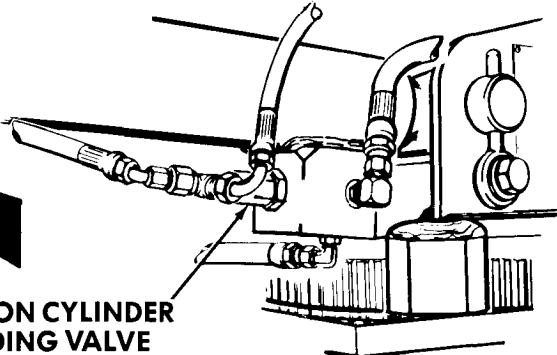
Malfunction	Test or Inspection	Corrective Action
MATERIAL HANDLING CRANE (M977, M985, M984E1) (CONT)		
5. MAST RAISES OR LOWERS ERRATICALLY, SLOWLY, OR WILL NOT RAISE AND LOWER.		
 <p data-bbox="551 768 629 795">M977</p>		<p>ERECTION CYLINDER HOLDING VALVE</p>
<p>M977 SHOWN M984E1 AND M985 SIMILAR</p>		
TA476857		
Step 1. Refer to HYDRAULIC SYSTEM troubleshooting.		
If problem remains, go to step 2.		
Step 2. Check for damaged erection cylinder lines, damaged erection cylinder, and damaged tension cylinders (para 17-19.2).		
Replace damaged lines (para 17-2 for M977 and M985), (para 17-2.1 for M984E1). Refer to step 6 if erection cylinder appears damaged.		
<u>WARNING</u>		
Do not loosen any erection cylinder holding valve unless crane is in stowed position or mast is blocked. Mast will drop and can cause injury or death.		
<u>NOTE</u>		
<ul style="list-style-type: none"> • Crane must be moved to gain access to cylinder holding valve. • M984E1 has one holding valve. 		
Step 3. Check for contaminated erection cylinder holding valves.		
Remove, clean, inspect, and install erection cylinder holding valves (para 17-15) but do not remove erection cylinder.		
Step 4. Check for contaminated mast directional control spool valve.		
Remove, disassemble, clean, inspect, assemble, and install mast directional control valve spool (para 17-28 for M977 and M985), (para 17-28.1 for M984E1).		

Troubleshooting Malfunctions (Cont)

2-7. TROUBLESHOOTING INSTRUCTIONS (CONT).

Table 2-3. Troubleshooting (Cont)

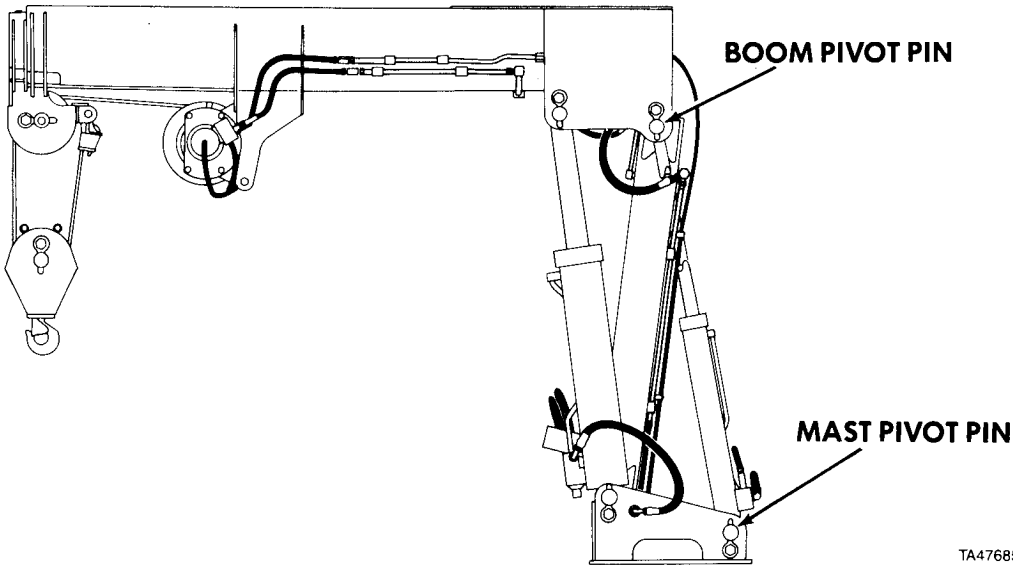
Malfunction	Test or Inspection	Corrective Action
MATERIAL HANDLING CRANE (M977, M985, M984E1) (CONT)		
5. MAST RAISES OR LOWERS ERRATICALLY, SLOWLY, OR WILL NOT RAISE AND LOWER (CONT).		
 <p style="text-align: right;">TA476858</p>		
<p>Step 5. Check for bent mast or boom pivot pin.</p> <p style="padding-left: 40px;">Remove, clean, inspect, and install boom pivot pin (para 17-10 for M977 and M985), (para 17-10.1 for M984E1).</p> <p style="padding-left: 40px;">Remove, clean, inspect, and install mast pivot pin (para 17-11 for M977 and M985), (para 17-11.1 for M984E1).</p> <p>Step 6. Check for damaged erection cylinders.</p> <p style="padding-left: 40px;">Replace erection cylinders (para 17-14 for M977 and M985), (para 17-14.1 for M984E1).</p>		

Troubleshooting Malfunctions (Cont)
 Table 2-3. Troubleshooting (Cont)

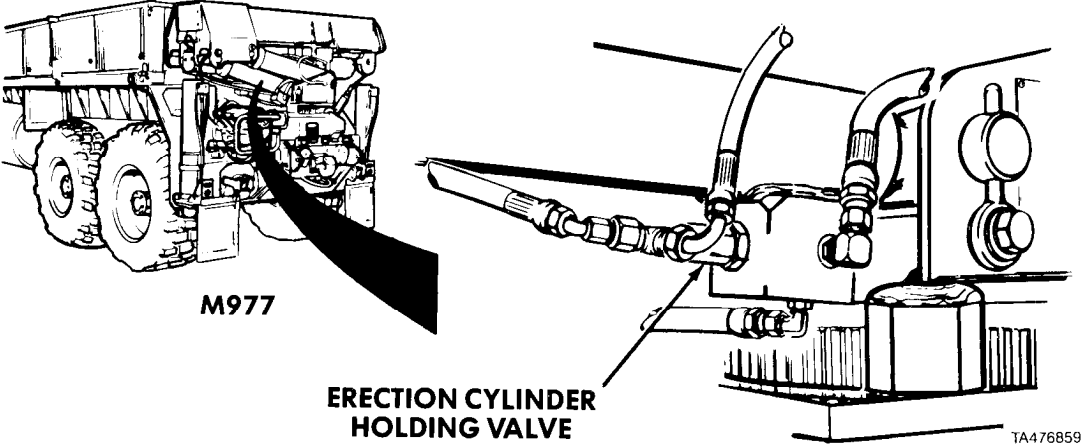
Malfunction	Test or Inspection	Corrective Action
MATERIAL HANDLING CRANE (M977, M985, M984E1) (CONT)		
6. MAST WILL NOT HOLD RAISED POSITION.		
		
<u>WARNING</u>		
<p>Do not loosen any erection cylinder holding valve unless crane is in stowed position or mast is blocked. Mast will drop and can cause injury or death.</p>		
<u>NOTE</u>		
<p>M984E1 has one erection cylinder.</p>		
<p>Step 1. Operate mast up and down several times (TM 9-2320-279-10).</p>		
<p style="padding-left: 40px;">If mast still does not hold position replace erection cylinder holding valve (para 17-15). Do not remove erection cylinder.</p>		
<p>Step 2. Check for damaged erection cylinders.</p>		
<p style="padding-left: 40px;">Replace erection cylinders (para 17-14 for M977 and M985), (para 17-14.1 for M984E1).</p>		

Troubleshooting Malfunctions (Cont)

2 7. TROUBLESHOOTING INSTRUCTIONS (CONT).

Table 2-3. Troubleshooting (Cont)

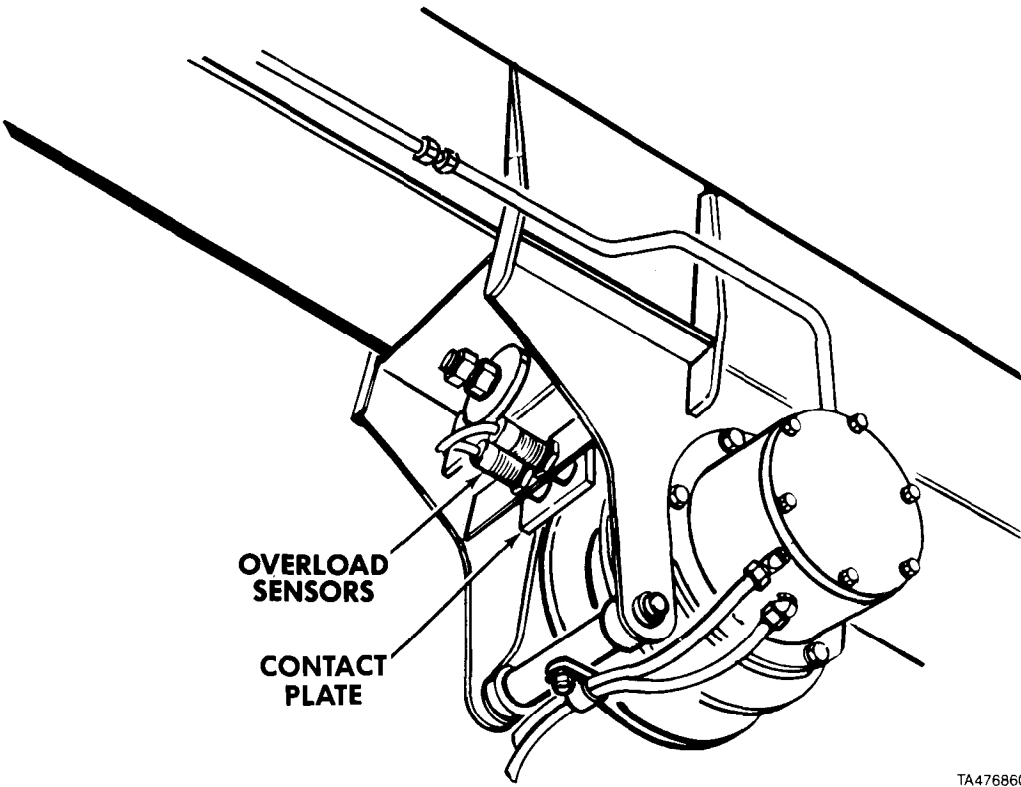
Malfunction	Test or Inspection	Corrective Action
MATERIAL HANDLING CRANE (M977, M985, M984E1) (CONT)		
7. BOOM OPERATES ABNORMALLY, SLOWLY, WILL NOT TELESCOPE IN OR OUT, OR RAISE OR LOWER.		
 <p>The diagram shows a detailed view of the crane boom's hydraulic and electrical control components. Two sensors are labeled 'OVERLOAD SENSORS' and are positioned near a 'CONTACT PLATE'. The boom is shown in a partially extended position, with various cables and hydraulic lines connected to the control system.</p>		
TA476860		
<u>WARNING</u>		
<p>This is only a rough adjustment. Crane requires a final adjustment or personal injury could result.</p>		
<p>Step 1. Check for overload sensor switch out of adjustment. Insert a 1/16-in. (1.6 mm) metal shim between each overload sensor and contact plate, one at a time. Operate crane (TM 9-2320-279-10). TELESCOPE boom OUT.</p>		
<p style="padding-left: 40px;">If boom extends, adjust and tighten overload sensor switch (para 17-33 for M977 and M985), (para 17-33.1 for M984E1).</p>		

Troubleshooting Malfunctions (Cont)
 Table 2-3. Troubleshooting (Cont)

Malfunction	Test or Inspection	Corrective Action
-------------	--------------------	-------------------

MATERIAL HANDLING CRANE (M977, M985, M984E1) (CONT)

7. BOOM OPERATES ABNORMALLY, SLOWLY, WILL NOT TELESCOPE IN OR OUT, OR RAISE OR LOWER (CONT).

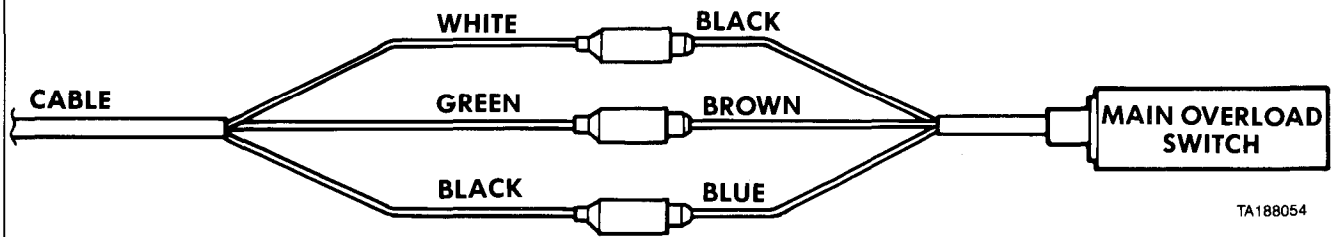

Step 2. *M977, M985 ONLY.* Check for defective main overload sensor switch. Remove sensor switch from mounting plate. Disconnect black and white sensor switch wires from connectors. Set ENGINE, PTO ENGAGE and crane POWER switches to ON. Set multimeter to test for 18 to 30 vdc. Touch positive (+) probe to black wire and negative (-) probe to white wire. Meter should show 24 vdc. Place metal shim against sensor switch face. Meter should show no voltage.

If meter does not show 24 vdc without shim and no voltage with shim, replace main overload sensor switch (para 6-12 for M977 and M985), (para 6-12.1 for M984E1).

Troubleshooting Malfunctions (Cont)

2-7. TROUBLESHOOTING INSTRUCTIONS (CONT).

Table 2-3. Troubleshooting (Cont)

Malfunction	Test or Inspection	Corrective Action
MATERIAL HANDLING CRANE (M977, M985, M984E1) (CONT)		
7. BOOM OPERATES ABNORMALLY, SLOWLY, WILL NOT TELESCOPE IN OR OUT, OR RAISE OR LOWER (CONT).		
		<p>Step 3. <i>M977 only.</i> Check for defective reduced overload sensor switch. Remove sensor switch from mounting plate. Disconnect black and white sensor switch wires from connectors. Set ENGINE, PTO ENGAGE, and crane POWER switches to ON. Set multimeter to test for 18 to 30 vdc. Touch positive (+) probe to black wire and negative (-) probe to white wire. Meter should show 24 vdc. Place metal shim against sensor switch face. Meter should show no voltage.</p> <p style="padding-left: 40px;">If meter does not show 24 vdc without shim and no voltage with shim, replace reduced overload sensor switch (para 6-12).</p>
		<p>Step 4. <i>M977 only.</i> Check for defective mast overload sensor switch. Disconnect black sensor switch wire from connector. Disconnect brown sensor switch wire from connector. Disconnect one green wire from connector. Connect green wire to brown mast overload sensor switch wire. Set ENGINE, PTO ENGAGE, and crane POWER switches to ON. Set multimeter to test for 18 to 30 vdc. Touch positive (+) probe to black sensor switch wire and negative (-) probe to ground. Meter should show 24 vdc. Place metal shim against sensor switch face. Meter should show no voltage.</p> <p style="padding-left: 40px;">If meter does not show 24 vdc without shim and no voltage with shim, replace mast overload sensor switch (para 6-12).</p>

TA188055

Troubleshooting Malfunctions (Cont)
 Table 2-3. Troubleshooting (Cont)

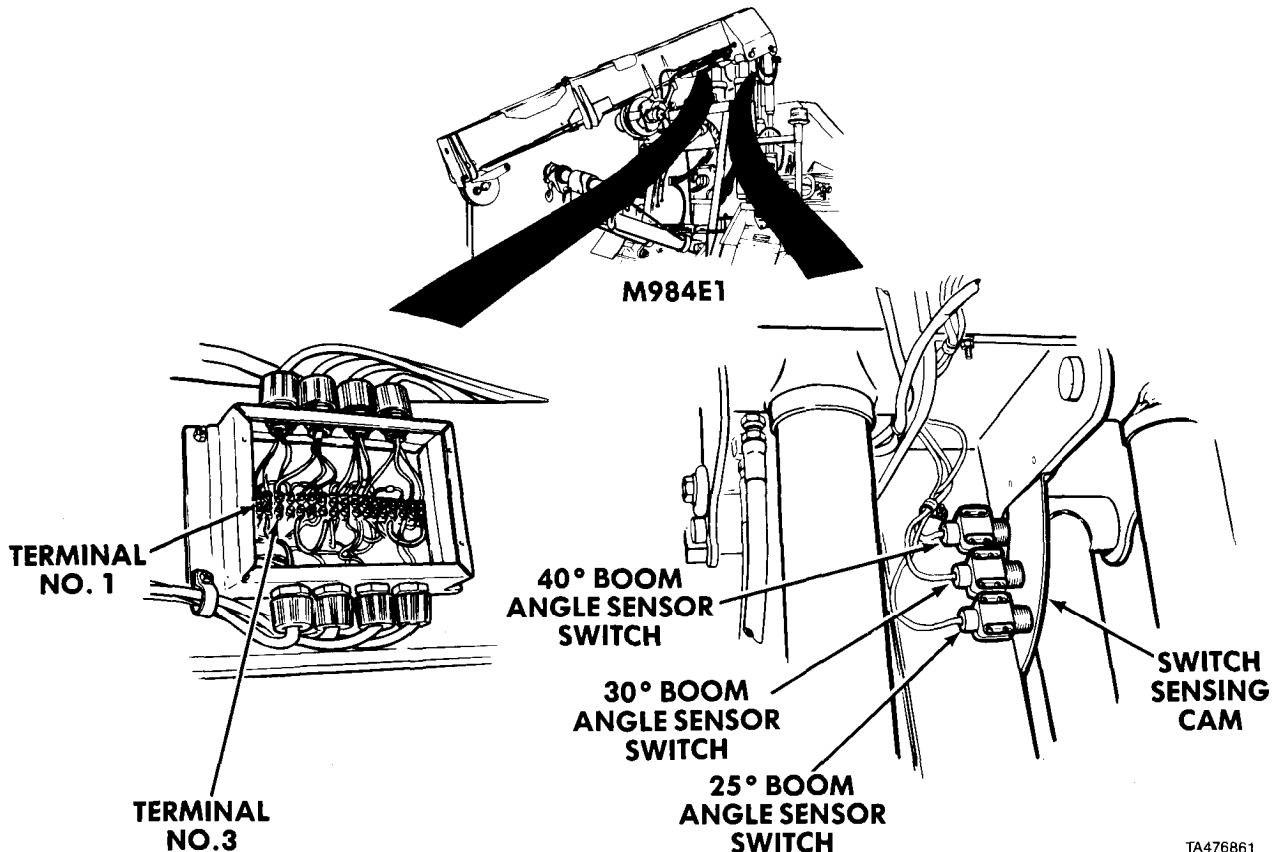
Malfunction	Test or Inspection	Corrective Action
MATERIAL HANDLING CRANE (M977, M985, M984E1) (CONT)		
7. BOOM OPERATES ABNORMALLY, SLOWLY, WILL NOT TELESCOPE IN OR OUT, OR RAISE OR LOWER (CONT).		
NOTE		
<ul style="list-style-type: none"> • Position boom over cargo body to gain access to terminal box and overload sensors. • Emergency hydraulic power can be used to position crane (TM 9-2320-279-10). 		
<div style="text-align: center;">  <p>The diagram shows a crane boom labeled M984E1. Below it is a terminal box with two terminals labeled 'TERMINAL NO. 1' and 'TERMINAL NO. 3'. To the right, three angle sensor switches are shown: '40° BOOM ANGLE SENSOR SWITCH', '30° BOOM ANGLE SENSOR SWITCH', and '25° BOOM ANGLE SENSOR SWITCH'. A 'SWITCH SENSING CAM' is also indicated. The diagram illustrates the location of these components on the crane boom.</p> </div>		
<p>Step 5. (M984E1 only). Check for defective 25° boom angle sensor switch. Remove cover from terminal box (para 6-12.1). Lower boom to cover all three switches with switch sensing CAM. Remove black wire from terminal No. 1. Set all electrical switches for crane operation (TM 9-2320-279-10). Touch positive (+) probe of multimeter to black wire and negative (-) probe to terminal No. 3. Meter should show 24 vdc.</p>		
<p>If meter does not show 24 vdc, replace 25° boom angle sensor switch (para 6-12.1).</p>		

TA476861

Troubleshooting Malfunctions (Cont)

2-7. TROUBLESHOOTING INSTRUCTIONS (CONT).

Table 2-3. Troubleshooting (Cont)

Malfunction	Test or Inspection	Corrective Action
MATERIAL HANDLING CRANE (M977, M985, M984E1) (CONT)		
7. BOOM OPERATES ABNORMALLY, SLOWLY, WILL NOT TELESCOPE IN OR OUT, OR RAISE OR LOWER (CONT).		
<p>Step 6. (<i>M984E1 only</i>). Raise boom so that switch sensing CAM covers only 2 boom angle sensor switches. Remove black wire from terminal No. 7. Set all electrical switches for crane operation (TM 9-2320-279-10). Touch positive (+) probe of multimeter to black wire and negative (-) probe to terminal No. 6. Meter should show 24 vdc.</p>		
<p style="padding-left: 40px;">If meter does not show 24 vdc, replace 30° boom angle sensor switch (para 6-12.1).</p>		
<p>Step 7. (<i>M984E1 only</i>). Raise boom so that switch sensing CAM covers one boom angle sensor switch. Remove black wire from terminal No. 10. Set all electrical switches for crane operation (TM 9-2320-279-10). Touch positive (+) probe of multimeter to black wire and negative (-) probe to terminal No. 12. Meter should show 24 vdc.</p>		
<p style="padding-left: 40px;">If meter does not show 24 vdc, replace 40° boom angle sensor switch (para 6-12.1).</p>		

TA476862

Troubleshooting Malfunctions (Cont)

Table 2-3. Troubleshooting (Cont)

Malfunction	Test or Inspection	Corrective Action
-------------	--------------------	-------------------

MATERIAL HANDLING CRANE (M977, M985, M984E1) (CONT)

7. BOOM OPERATES ABNORMALLY, SLOWLY, WILL NOT TELESCOPE IN OR OUT, OR RAISE OR LOWER (CONT).

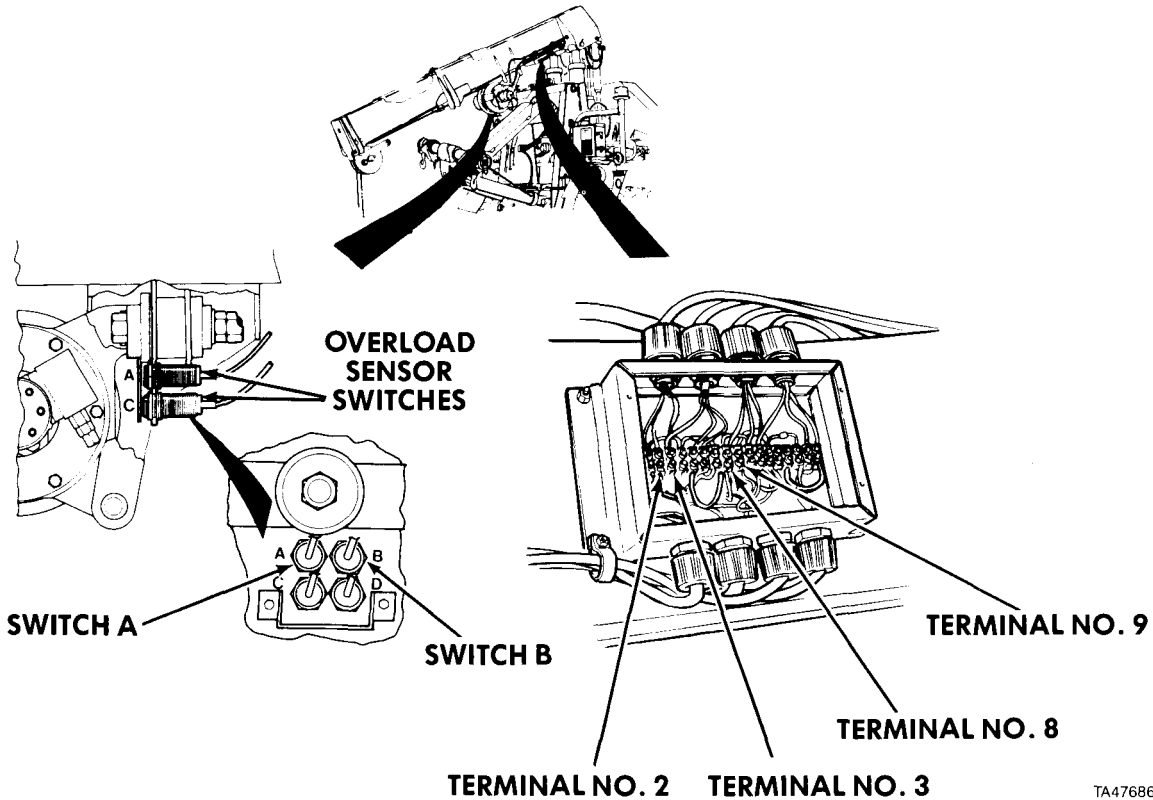

TA476863

Step 8. (M984E1 only). Lower boom so that switch sensing CAM covers three boom angle switches. Remove black wire from terminal No. 2. Remove overload sensor switch A making sure no metal is near switch (para 6-12.1). Set all electrical switches for crane operation (TM 9-2320-279-10). Touch positive (+) probe of meter to black wire and negative (-) probe to terminal No. 3. Meter should show 24 vdc. Place metal shim against sensor switch face. Meter should show no voltage.

If meter does not show 24 vdc without shim and no voltage with shim, replace overload sensor switch A (para 6-12.1).

Step 9. (M984E1 only). Raise boom so that switch sensing CAM covers two boom angle switches. Remove black wire from terminal No. 8. Remove overload sensor switch B, making sure no metal is near switch (para 6-12.1). Set all electrical switches for crane operation (TM 9-2320-279-10). Touch positive (+) probe of meter to black wire and negative (-) probe to terminal No. 9. Meter should show 24 vdc. Place metal shim against sensor switch face. Meter should show no voltage.

If meter does not show 24 vdc without shim and no voltage with shim, replace overload sensor switch B (para 6-12.1).

Troubleshooting Malfunctions (Cont)

2-7. TROUBLESHOOTING INSTRUCTIONS (CONT).

Table 2-3. Troubleshooting (Cont)

Malfunction Test or Inspection	Corrective Action
MATERIAL HANDLING CRANE (M977, M985, M984E1) (CONT)	
7. BOOM OPERATES ABNORMALLY, SLOWLY, WILL NOT TELESCOPE IN OR OUT, OR RAISE OR LOWER (CONT).	
<p>The diagram consists of two parts. On the left, a perspective view of an electrical terminal block shows four terminals labeled: TERMINAL NO. 11, TERMINAL NO. 12, TERMINAL NO. 17, and TERMINAL NO. 19. On the right, a detail view of the 'OVERLOAD SENSOR SWITCHES' shows four switches labeled A, B, C, and D. A callout line connects 'SWITCH C' in this detail to terminal 11 in the terminal block. Another callout line connects 'SWITCH D' to terminal 17. A third callout line connects 'SWITCH C' to terminal 19. A fourth callout line connects 'SWITCH D' to terminal 12.</p>	
<p>Step 10. (M984E1 only). Raise boom so that switch sensing CAM covers angle sensor switch. Remove black wire from terminal No. 11. Remove overload sensor switch C, making sure no metal is near switch (para 6-12.1). Set all electrical switches for crane operation (TM 9-2320-279-10). Touch positive (+) probe of multimeter to black wire and negative (-) probe to terminal No. 12. Meter should show 24 vdc. Place metal shim against sensor switch face. Meter should show no voltage.</p> <p style="padding-left: 40px;">If meter does not show 24 vdc without shim and no voltage with shim, replace overload sensor switch C (para 6-12.1).</p>	
<p>Step 11. (M984E1 only). Raise boom to uncover all three boom angle switches. Remove black wire from terminal No. 17. Remove overload sensor switch D, making sure no metal is near switch (para 6-12.1). Set all electrical switches for crane operation (TM 9-2320-279-10). Touch positive (+) probe of meter to black wire and negative (-) probe to terminal No. 19. Meter should show 24 vdc. Place metal shim against switch face. Meter should show no voltage.</p> <p style="padding-left: 40px;">If meter does not show 24 vdc without shim and no voltage with shim, replace overload sensor switch D (para 6-12.1).</p>	

TA476864

Troubleshooting Malfunctions (Cont)
 Table 2-3. Troubleshooting (Cont)

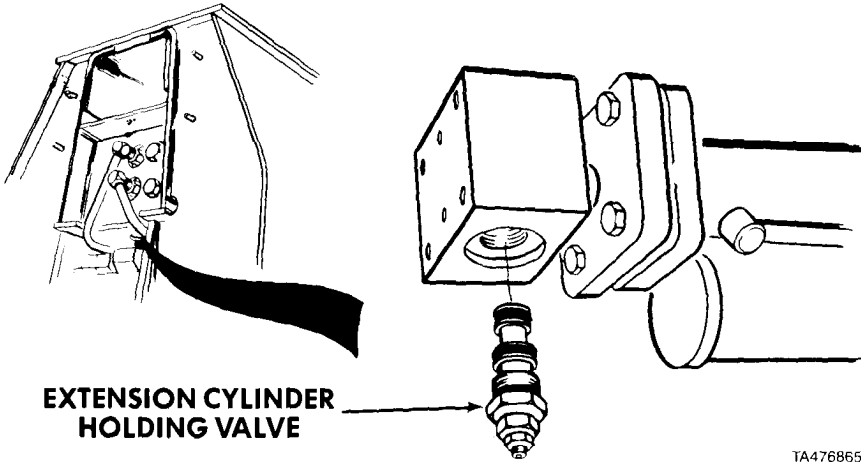
Malfunction	Test or Inspection	Corrective Action
MATERIAL HANDLING CRANE (M977, M985, M984E1) (CONT)		
7. BOOM OPERATES ABNORMALLY, SLOWLY, WILL NOT TELESCOPE IN OR OUT, OR RAISE OR LOWER (CONT).		
Step 12. Refer to HYDRAULIC SYSTEM troubleshooting.		
If problem remains, go to step 2.		
Step 13. Check hoist operation to be sure hoist is not causing problem. Operate crane (TM 9-2320-279-10). Operate HOIST DOWN control to let out cable.		
If hoist does not work properly, go to MALFUNCTION 21, HOIST OPERATION ERRATIC WHEN LOWERING LOAD.		
Step 14. Check for damaged extension cylinder lines and damaged extension cylinder.		
Replace damaged lines (para 17-2 for M977 and M985), (para 17-2.1 for M984E1).		
Refer to step 17 if extension cylinder is damaged.		
 <p>The diagram consists of two parts. On the left, a perspective view of a crane boom shows the location of the extension cylinder holding valve, indicated by a thick black arrow pointing to a specific point on the boom's structure. On the right, a detailed technical drawing of the extension cylinder holding valve is shown. It is a cylindrical component with a central threaded hole and a conical valve seat. A label 'EXTENSION CYLINDER HOLDING VALVE' with an arrow points to this central valve seat. The drawing also shows the valve's mounting flange and a hydraulic line connection.</p>		
TA476865		
<u>WARNING</u>		
Do not loosen extension cylinder holding valve unless crane boom is blocked. Boom will drop and can cause injury or death.		
Step 15. Check for contaminated or damaged extension cylinder holding valve.		
Remove, clean, inspect, and install extension cylinder holding valve (para 17-19 for M977 and M985), (para 17-19.1 for M984E1).		

2-7. TROUBLESHOOTING INSTRUCTIONS (CONT).

Table 2-3. Troubleshooting (Cont)

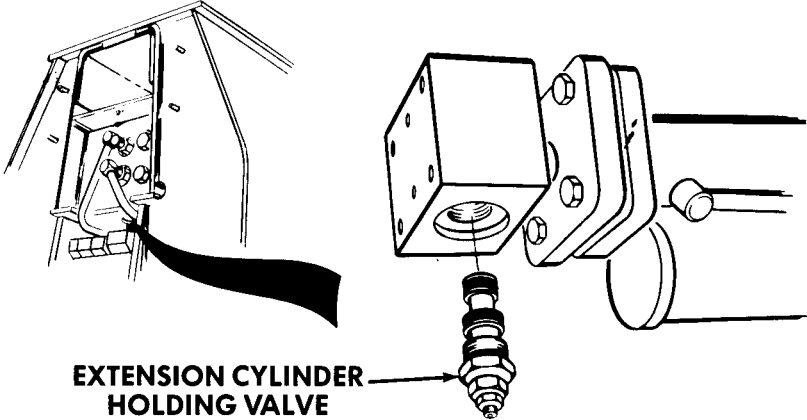
Malfunction	Test or Inspection	Corrective Action
MATERIAL HANDLING CRANE (M977, M985, M984E1) (CONT)		
7. BOOM OPERATES ABNORMALLY, SLOWLY, WILL NOT TELESCOPE IN OR OUT, OR RAISE OR LOWER (CONT).		
<p>Step 16. Check for damaged boom extension and worn boom wear pads. Fully TELESCOPE boom OUT (TM 9-2320-279-10). Look at boom sections while telescoping boom IN and OUT to make sure boom sections maintain alinement and move freely without binding.</p>		
<p style="padding-left: 40px;">If alinement changes while telescoping, or if boom chatters, remove, inspect, and install boom, extensions, and wear pads (paras 17-12, 17-13, and 17-10 for M977 and M985), (paras 17-12.1, 17-13.1, and 17-10.1 for M984E1).</p>		
<p>Step 17. Check for damaged extension cylinder.</p>		
<p style="padding-left: 40px;">Replace extension cylinder (para 17-18 for M977 and M985) (para 17-18.1 for M984E1).</p>		
8. BOOM OPERATION ERRATIC WHEN TELESCOPING IN.		
<p>Step 1. Refer to HYDRAULIC SECTION troubleshooting.</p>		
<p style="padding-left: 40px;">If problem remains, go to step 2.</p>		
 <p>The diagram consists of two parts. On the left, a perspective view of a crane boom shows the internal hydraulic lines and a valve assembly. A thick black arrow points from this valve assembly to a detailed cross-sectional view of the valve on the right. The detailed view shows a cylindrical valve body with a central threaded stem and a conical valve seat. The text 'EXTENSION CYLINDER HOLDING VALVE' is printed below the detailed view with an arrow pointing to the stem.</p>		
TA356203		
<p>Step 2. Check for damaged extension cylinder lines and damaged extension cylinder.</p>		
<p style="padding-left: 40px;">Replace damaged extension cylinder lines (para 17-2 for M977 and M985) (para 17-2.1 for M984E1).</p>		
<p style="padding-left: 40px;">Refer to step 6 if extension cylinder is damaged.</p>		

Troubleshooting Malfunctions (Cont)
 Table 2-3. Troubleshooting (Cont)

Malfunction	Test or Inspection	Corrective Action
MATERIAL HANDLING CRANE (M977, M985, M984E1) (CONT)		
8. BOOM OPERATION ERRATIC WHEN TELESCOPING IN (CONT).		
<u>WARNING</u>		
Do not loosen extension cylinder holding valve unless crane boom is blocked. Boom will drop and can cause injury or death.		
Step 3. Check for contaminated or damaged extension cylinder holding valve.	Remove, clean, inspect, and install extension cylinder holding valve (para 17-19 for M977 and M985) (para 17-19.1 for M984E1). Do not remove extension cylinder.	
Step 4. Check for damaged boom extension and worn boom wear pads. Fully TELESCOPE boom OUT (TM 9-2320-279-10). Look at boom sections while telescoping boom IN and OUT to make sure boom sections maintain alinement and move freely without binding.	If alinement changes while telescoping, or if boom chatters, remove, inspect, and install boom, extensions, and wear pads (paras 17-12, 17-13, and 17-10 for M977 and M985) (para 17-12.1, 17-13.1, and 17-10.1 for M984E1).	
Step 5. Check for damaged or contaminated directional control valve spool.	Remove, clean, inspect, and install directional control valve spool (para 17-28 for M977 and M985) (para 17-28.4 for M984E1).	
Step 6. Check that boom operates smoothly when telescoping in (TM 9-2320-279-10).	Replace extension cylinder holding valve (para 17-19 for M977 and M985) (para 17-19.1 for M984E1). Do not remove extension cylinder.	
Step 7. Check for damaged extension cylinder.	Replace cylinder (para 17-18 for M977 and M985) (para 17-18.1 for M984E1).	

Troubleshooting Malfunctions (Cont)

2-7. TROUBLESHOOTING INSTRUCTIONS (CONT).

Table 2-3. Troubleshooting (Cont)

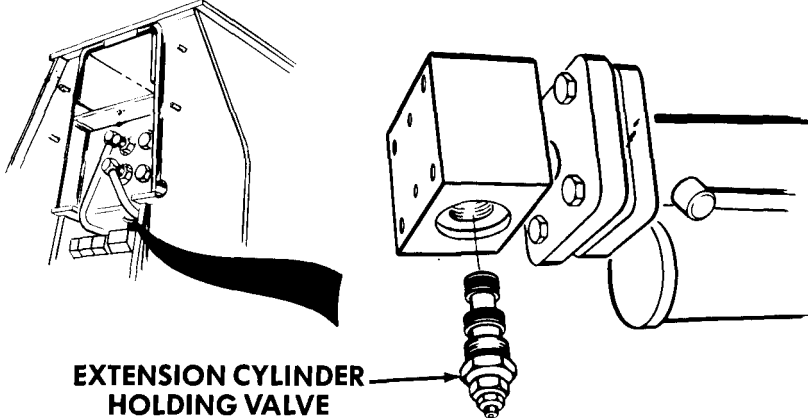
Malfunction	Test or Inspection	Corrective Action
MATERIAL HANDLING CRANE (M977, M985, M984E1) (CONT)		
9. BOOM WILL NOT TELESCOPE OUT.		
 <p data-bbox="444 1017 740 1072">EXTENSION CYLINDER HOLDING VALVE</p> <p data-bbox="1111 1083 1179 1098">TA356203</p>		
<p>Step 1. Check for damaged extension cylinder lines. Replace damaged lines (para 17-2 for M977 and M985) (para 17-2.1 for M984E1).</p> <p>Step 2. Check for contaminated or damaged extension cylinder holding valve. Remove, clean, inspect, and install extension cylinder holding valve (para 17-19 for M977 and M985) (para 17-19.1 for M984E1).</p> <p>Step 3. Check overload sensor switch adjustment (para 17-33 for M977 and M985) (para 17-33.1 for M984E1). If switch(es) cannot be adjusted, replace (para 6-12 for M977 and M985) (para 6-12.1 for M984E1).</p> <p>Step 4. Check for contaminated or damaged telescope directional control valve spool. Remove, clean, inspect, and install directional control valve spool (para 17-28 for M977 and M985) (para 17-28.4 for M984E1).</p> <p>Step 5. Check for damaged boom extension sections and cylinder. Replace extension No. 1 (para 17-12 for M977 and M985) (para 17-12.1 for M984E1), extension No. 2 (para 17-13 for M977 and M985) (para 17-13.1 for M984E1), and extension cylinder (para 17-18 for M977 and M985) (para 17-18.1 for M984E1).</p>		

Troubleshooting Malfunctions (Cont)
Table. 2-3. Troubleshooting (Cont)

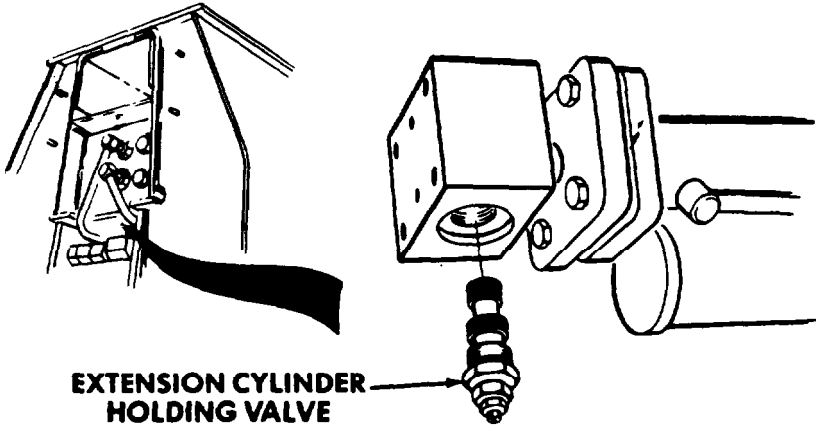
Malfunction	Test or Inspection	Corrective Action
MATERIAL HANDLING CRANE (M977, M985, M984E1) (CONT)		
10. BOOM WILL NOT TELESCOPE IN.		
 <p style="text-align: right; margin-right: 50px;">TA368203</p>		
	Step 1. Check for damaged extension cylinder lines.	Replace damaged extension cylinder lines (para 17-2 for M977 and M985) (para 17-2.1 for M984E1).
	Step 2. Check for contaminated or damaged extension cylinder holding valve.	Remove, clean, inspect, and install extension cylinder holding valve (para 17-19 for M977 and M985) (para 17-19.2 for M984E1). Do not remove extension cylinder.
	Step 3. Check for overload sensor switch adjustment (para 17-33 for M977 and M985) (para 17-33.1 for M984E1).	If switch(es) cannot be adjusted, replace (para 6-12 for M977 and M985) (para 6-12.1 for M984E1).
	Step 4. Check for contaminated or damaged telescope directional control valve spool.	Remove, clean, inspect, and install directional control valve spool (para 17-28 for M977 and M985) (para 17-28.4 for M984E1).
	Step 5. Check for damaged boom extension sections and cylinder.	Remove extension No. 1 (para 17-12 for M977 and M985) (para 17-12.1 for M984E1), extension No. 2 (para 17-13 for M977 and M985) (para 17-13.1 for M984E1), and extension cylinder (para 17-18 for M977 and M985) (para 17-18.1 for M984E1).

Troubleshooting Malfunctions (Cont)

2-7. TROUBLESHOOTING INSTRUCTIONS (CONT.).

Table 2-3. Troubleshooting (Cont)

Malfunction Test or Inspection	Corrective Action
MATERIAL HANDLING CRANE (M977, M985, M984A1) (CONT)	
11. BOOM RAISES OR LOWERS SLOWLY.	
<p>step 1. Refer to HYDRAULIC SYSTEM troubleshooting. If problem remains, go to step 2.</p> <p>Step 2. Check for damaged lift cylinder lines and damaged lift cylinder. Replace damaged lift cylinder lines (para 17-2 for M977 and M985) (para 17-2.1 for M984E1). Refer to step 6 if lift cylinder appears damaged.</p>	
<u>WARNING</u>	
<p>Do not loosen both lift cylinder holding valves unless crane is in stowed position or boom is blocked. Boom will drop and can cause injury or death.</p>	
<p>Step 3. Check for contaminated or damaged lift cylinder holding valve. Remove, clean, inspect, and install lift cylinder holding valve (para 17-17). Do not remove lift cylinder.</p>	

Troubleshooting Malfunctions (Cont)

Table 2-3. Troubleshooting(Cont)

Malfunction	Test or Inspection	Corrective Action
MATERIAL HANDLING CRANE (M977, M985, M984E1) (CONT)		
Step 4.	Check main hydraulic pressure adjustment (para 17-31 for M977 and M985) (para 17-31.1 for M984E1).	If main hydraulic pressure cannot be adjusted, repair crane control valve (para 17-28 for M977 and M985) (para 17-28.4 for M984E1).
Step 4.1	Check for contaminated or damaged boom relief valve.	Remove, clean, inspect, and install boom relief valve (para 17-32.1).

Troubleshooting Malfunctions (Cont)
 Table 2-3. Troubleshooting (Cont)

Malfunction
Test or Inspection

Corrective Action

MATERIAL HANDLING CRANE (M977, M985, M984E1) (CONT)

11. BOOM RAISES OR LOWERS SLOWLY (CONT).

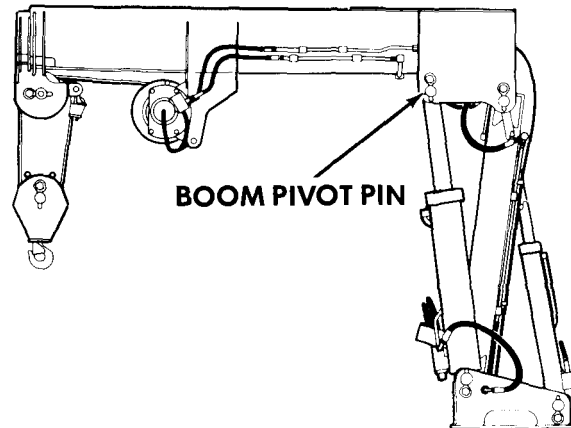

TA356247

Step 5. Check for damaged boom pivot pin.

Remove, clean, inspect, and install boom pivot pin (para 17-10).

Step 6. Check for damaged lift cylinders.

Replace lift cylinders (para 17-16 for M977 and M985) (para 17-16.1 for M984E1).

12. BOOM WILL NOT RAISE.

Step 1. Refer to HYDRAULIC SYSTEM troubleshooting.

If problem remains, go to step 2.

Step 2. Check for damaged lift cylinder lines and damaged lift cylinder.

Replace damaged lines (para 17-2 for M977 and M985) (para 17-2.1 for M984E1).

Refer to step 8 if lift cylinder is damaged.

Step 3. Check overload sensor switch adjustment (para 17-33 for M977 and M985) (para 17-33.1 for M984E1).

If switch(es) cannot be adjusted, replace (para 6-12 for M977 and M985)
 (para 6-12.1 for M984E1).

Step 4. Check main hydraulic pressure adjustment (para 17-31 for M977 and M985) (para 17-31.1 for M984E1) with BOOM control. Slowly operate BOOM control UP.

If pressure cannot be adjusted, replace main relief valve (para 17-28 for M977 and M985) (para 17-28.4 for M984E1).

Troubleshooting Malfunctions (Cont)

2-7. TROUBLESHOOTING INSTRUCTIONS (CONT).

Table 2-3. Troubleshooting (Cont)

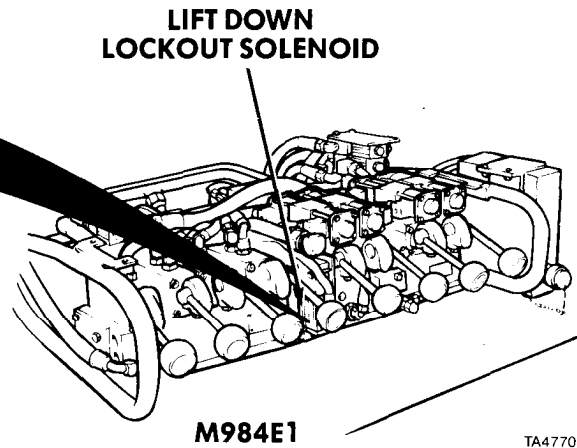
Malfunction	Test or Inspection	Corrective Action
MATERIAL HANDLING CRANE (M977, M985, M984E1) (CONT)		
12. BOOM WILL NOT RAISE (CONT).		
	<p>TERMINAL NO. 1 (-) WIRE NO. 2</p>	
<p>Step 5. (M984E1). Check for malfunctioning lift down lockout solenoid. Start ENGINE, PTO ENGAGE, and crane POWER switches to ON. Remove connector from solenoid. Check voltage between connector terminals No. 1 and No. 2.</p>		
<p style="padding-left: 40px;">If there is 24 to 30 vdc, replace lift down lockout solenoid (para 17-32.1).</p>		

TA477003

Troubleshooting Malfunctions (Cont)
 Table 2-3. Troubleshooting (Cont)

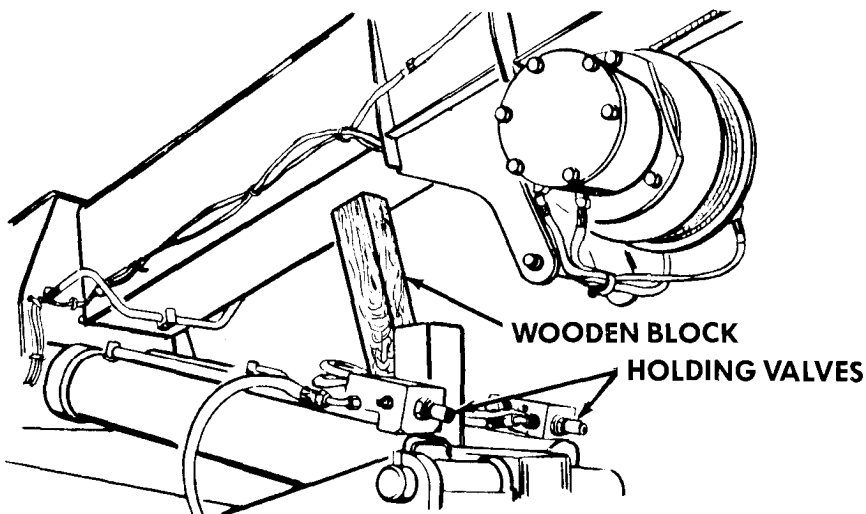
Malfunction	Test or Inspection	Corrective Action
MATERIAL HANDLING CRANE (M977, M985, M984E1) (CONT)		
12. BOOM WILL NOT RAISE (CONT).		
		
TA356202		
<u>WARNING</u>		
<p>Do not loosen both lift cylinder holding valves unless boom is blocked. Boom will fall and can cause injury or death.</p>		
<p>Step 6. Check for contaminated or damaged lift cylinder holding valve. Remove, clean, inspect, and install lift cylinder holding valve (para 17-17). Do not remove lift cylinders.</p> <p>Step 7. Check for contaminated or damaged boom directional control valve spool (para 17-28 for M977 and M985) (para 17-28.4 for M984E1).</p> <p>Step 8. Check for damaged lift cylinders. Replace lift cylinders (para 17-16 for M977 and M985) (para 17-16.1 for M984E1).</p>		

Troubleshooting Malfunctions (Cont)

2-7. TROUBLESHOOTING INSTRUCTIONS (CONT).

Table 2-3. Troubleshooting (Cont)

Malfunction	Test or Inspection	Corrective Action
MATERIAL HANDLING CRANE (M977, M985, M984E1) (CONT)		
13. BOOM WILL NOT LOWER (M977, M984E1).		
TA477004		
<p>Step 1. Check hydraulic lines on lift down lockout solenoid for damage. Replace damaged line (para 17-2 for M977 and M985) (para 17-2.1 for M984E1) and FO-3 Hydraulic Schematic).</p> <p>Step 2. Check for power to lift down lockout solenoid. Remove power cable connector for lockout solenoid. Set ENGINE, PTO ENGAGE, and crane POWER switches to ON. Check for 24 vdc to 30 vdc at connector terminals. If there is 24 to 30 vdc, replace lockout relay (M977 only). (M984E1) Refer to Malfunction No. 7. If problem still is not solved, replace defective relay module (para 6-11 for M977 and M985) (para 6-11.1 for M984E1). If there is no voltage, replace defective lift down lockout solenoid.</p> <p>Step 3. Check main hydraulic pressure adjustment (para 17-31 for M977 and M985) (para 17-31.1 for M984E1) with BOOM control. Slowly operate BOOM control DOWN. If pressure cannot be adjusted, replace main relief valve (para 17-28 for M977 and M985) (para 17-28.4 for M984E1).</p>		

Troubleshooting Malfunctions (Cont)
 Table 2-3. Troubleshooting (Cont)

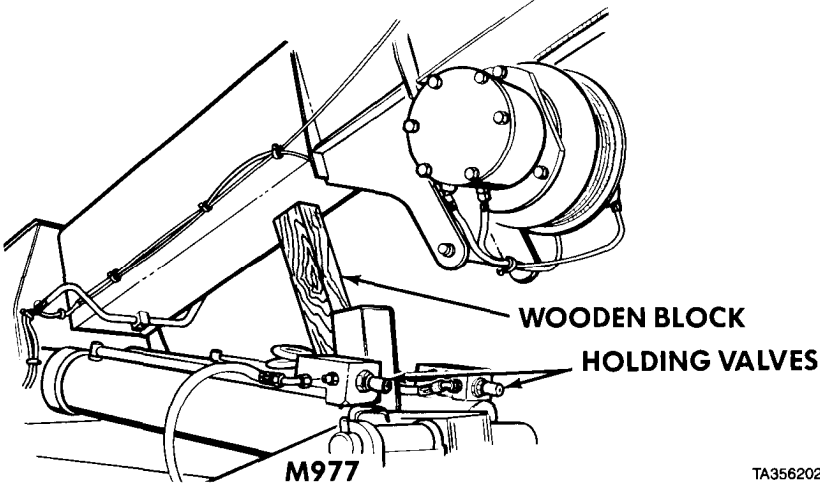
Malfunction	Test or Inspection	Corrective Action
MATERIAL HANDLING CRANE (M977, M985, M984E1) (CONT)		
13. BOOM WILL NOT LOWER (M977, M984E1) (CONT).		
	Step 4. Check for damaged boom directional control valve spool.	Remove, clean, inspect, and install directional control valve spool (para 17-28 for M977 and M985) (para 17-28.4 for M984E1).
	Step 5. Check for damaged lift cylinder holding valve.	Remove lift cylinder holding valve (para 17-17) clean, inspect holding valve.
	Step 6. Check for damaged lift cylinder.	Replace lift cylinder (para 17-16 for M977 and M985) (para 17-16.1 for M984E1).
14. BOOM WILL NOT HOLD LOAD.		
 <p style="text-align: right;">WOODEN BLOCK HOLDING VALVES</p> <p style="text-align: center;">M977</p> <p style="text-align: right;">TA356202</p>		
<u>WARNING</u>		
Do not remove both lift cylinder holding valves unless boom is blocked. Boom will drop and can cause injury or death.		
	Step 1. Check for contaminated or damaged lift cylinder holding valves.	Remove, clean, inspect, and install lift cylinder holding valves (para 17-17). Do not remove lift cylinders.

Troubleshooting Malfunctions (Cont)

2-7. TROUBLESHOOTING INSTRUCTIONS (CONT).

Table 2-3. Troubleshooting (Cont)

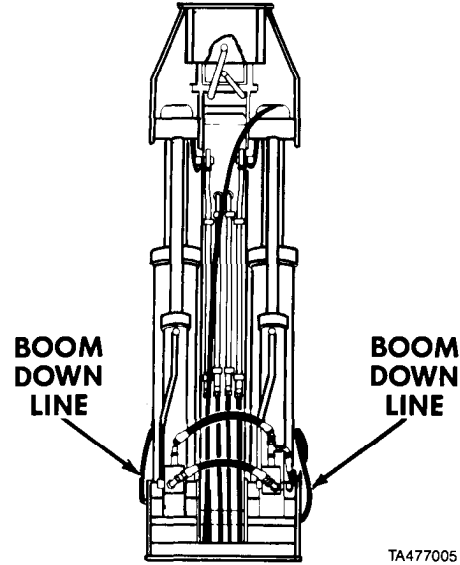
Malfunction	Test or Inspection	Corrective Action
MATERIAL HANDLING CRANE (M977, M985, M984E1) (CONT)		
14. BOOM WILL NOT HOLD LOAD (CONT).		
 <p style="text-align: right; margin-right: 50px;">TA477005</p>		
<p>Step 2. Check for contaminated or damaged boom directional control spool valve. Remove boom down lines from lift cylinders (para 17-2 for M977 and M985) (para 17-2.1 for M984E1). Operate crane (TM 9-2320-279-10). Do not touch BOOM control.</p>		
<p style="padding-left: 40px;">If oil flows from down lines, shut down crane (TM 9-2320-279-10). Remove, clean, inspect, and install directional control spool valve (para 17-28 for M977 and M985) (para 17-28.4 for M984E1).</p>		
<p>Step 3. Check for contaminated or damaged lift cylinders.</p> <p style="padding-left: 40px;">Replace lift cylinders (para 17-16 for M977 and M985) (para 17-16.1 for M984E1).</p>		
15. HOIST WILL NOT RAISE LOAD.		
<p>Step 1. Refer to HYDRAULIC SYSTEM troubleshooting.</p> <p style="padding-left: 40px;">If problem remains, go to step 2.</p>		
<p>Step 2. Check for damaged hoist motor lines.</p> <p style="padding-left: 40px;">Replace damaged hoist motor lines (para 17-2 for M977 and M985) (para 17-2.1 for M984E1).</p>		

Troubleshooting Malfunctions (Cont)
 Table 2-3. Troubleshooting (Cont)

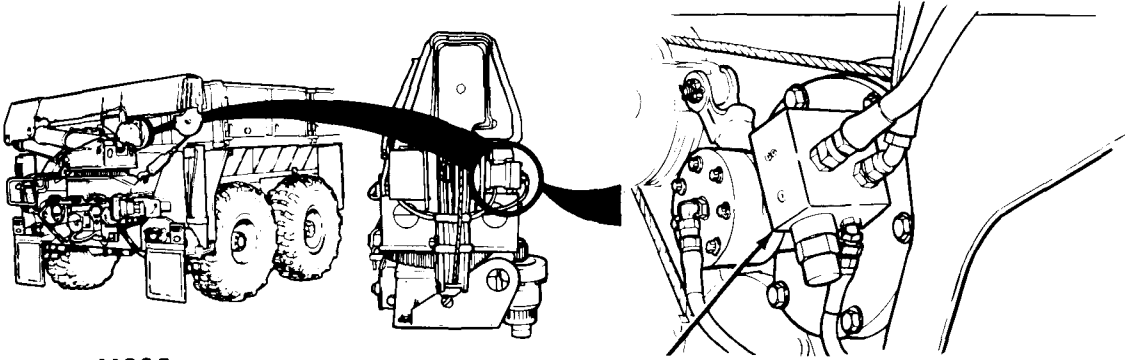
Malfunction	Test or Inspection	Corrective Action
MATERIAL HANDLING CRANE (M977, M985, M984E1) (CONT)		
15. HOIST WILL NOT RAISE LOAD (CONT).		
Step 3. Check for damaged hoist brake line.		
Replace damaged hoist brake lines (para 17-2 for M977 and M985) (para 17-2.1 for M984E1).		
Step 4. Check overload sensor switch adjustment (para 17-33 for M977 and M985) (para 17-33.1 for M984E1).		
If switch(es) cannot be adjusted, replace (para 6-12 for M977 and M985) (para 6-12.1 for M984E1).		
 <p data-bbox="401 1155 480 1183">M985</p> <p data-bbox="824 1166 1102 1221">HOIST DRIVE MOTOR CONTROL VALVE</p> <p data-bbox="1362 1215 1434 1229">TA477006</p>		
Step 5. Check for contaminated hoist drive motor control valve.		
Remove, clean, inspect, and install hoist drive motor control valve (para 17-21 for M977 and M985) (para 17-21.1 for M984E1).		

2-7. TROUBLESHOOTING INSTRUCTIONS (CONT).

Table 2-3. Troubleshooting (Cont)

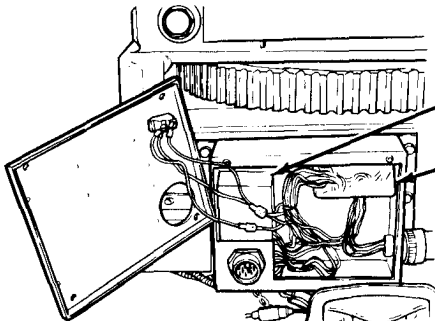
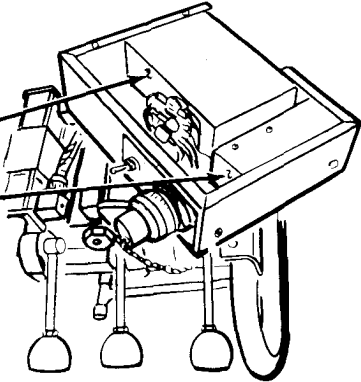
Malfunction	Test or Inspection	Corrective Action
MATERIAL HANDLING CRANE (M977, M985, M984E1) (CONT)		
15. HOIST WILL NOT RAISE LOAD (CONT).		
	<p>CABLE MODULE</p> <p>RELAY MODULE</p>	
M977, M985		M984E1
		TA477007
<p>Step 6. Check for defective junction box wiring.</p>		
NOTE		
<ul style="list-style-type: none"> • To remove junction box cover on M984E1, two screws, lockwashers, and nuts must be removed from box and mounting bracket and junction box positioned on top of 4-valve assembly. • Open cover on junction box (para 6-11 for M977 and M985) (para 6-11.1 for M984E1) and check wire No. 7 between cable module and relay module for breaks or loose connections (0-4, wiring diagram). Tighten loose connection or repair wire. 		
<p>Step 7. Check hoist adjustment (para 17-25 for M977 and M985) (para 17-25.1 for M984E1).</p>		
<p style="padding-left: 40px;">If hoist cannot be adjusted, replace hoist relief valve (para 17-28 for M977 and M985) (para 17-28.4 for M984E1).</p>		
<p>Step 8. Check for contaminated or damaged hoist directional control valve.</p>		
<p style="padding-left: 40px;">Remove, clean, inspect, and install hoist directional valve spool (para 17-28 for M977 and M985) (para 17-28.4 for M984E1).</p>		
<p>Step 9. Check main hydraulic pressure adjustment (para 17-31 for M977 and M985) (para 17-31.1 for M984E1).</p>		
<p style="padding-left: 40px;">If pressure cannot be adjusted, repair crane control valve body (para 17-28 for M977 and M985) (para 17-28.4 for M984E1).</p>		

Troubleshooting Malfunctions (Cont)
 Table 2-3. Troubleshooting (Cont)

Malfunction	Test or Inspection	Corrective Action
MATERIAL HANDLING CRANE (M977, M985, M984E1) (CONT)		
15. HOIST WILL NOT RAISE LOAD (CONT).		
<p>Step 10. Check for defective hoist assembly or hoist brake. Remove hoist brake (para 17-24 for M977 and M985) (para 17-24.1 for M984E1).</p>		
<p style="padding-left: 40px;">If drum binds or does not turn, repair hoist assembly (para 17-23).</p>		
<p style="padding-left: 40px;">If drum turns smoothly, repair hoist brake (para 17-24 for M977 and M985) (para 17-24.1 for M984E1).</p>		
<p>Step 11. Check for damaged hoist drive motor. Remove hoist drive motor (para 17-22 for M977 and M985) (para 17-22.1 for M984E1). Turn motor shaft by hand, checking for binding.</p>		
<p style="padding-left: 40px;">If there is binding, replace hoist drive motor (para 17-22 for M977 and M985) (para 17-22.1 for M984E1).</p>		

Troubleshooting Malfunctions (Cont)

2-7. TROUBLESHOOTING INSTRUCTIONS (CONT).

Table 2-30 Troubleshooting (Cont)

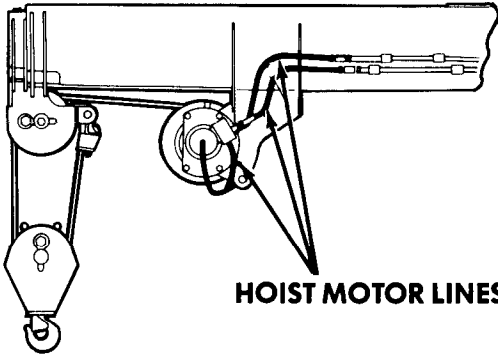
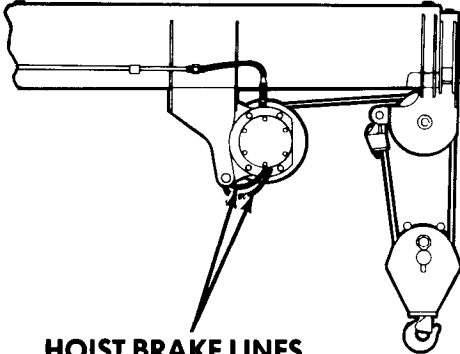
Malfunction	Test or Inspection	Corrective Action
MATERIAL HANDLING CRANE (M977, M985, M984E1) (CONT)		
16. HOIST WILL NOT LOWER.		
 <p style="text-align: center;">HOIST MOTOR LINES</p>	 <p style="text-align: center;">HOIST BRAKE LINES</p>	TA477008
<p>Step 1. Check for damaged hoist motor lines.</p>		
<p style="padding-left: 40px;">Replace damaged hoist drive motor lines (para 17-2 for M977 and M985) (para 17-2.1 for M984E1).</p>		
<p>Step 2. Check for damaged hoist brake lines.</p>		
<p style="padding-left: 40px;">Replace damaged hoist brake lines (para 17-2 for M977 and M985) (para 17-2.1 for M984E1).</p>		

Troubleshooting Malfunctions (Cont)
 Table 2-3. Troubleshooting (Cont)

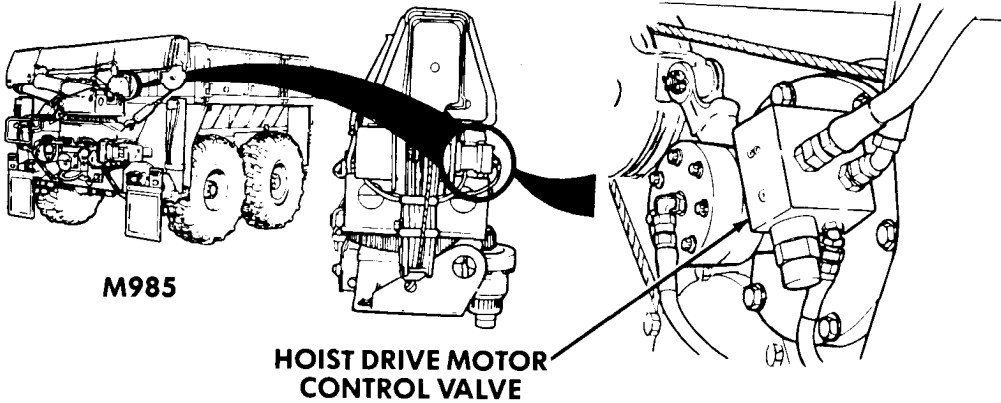
Malfunction	Test or Inspection	Corrective Action
MATERIAL HANDLING CRANE (M977, M985, M984E1) (CONT)		
16. HOIST WILL NOT LOWER (CONT).		
 <p style="text-align: center;">M985</p> <p style="text-align: center;">HOIST DRIVE MOTOR CONTROL VALVE</p> <p style="text-align: right;">TA477009</p>		
<p>Step 3. Check for damaged or contaminated hoist drive motor control valve.</p>		
<p style="padding-left: 40px;">Remove, disassemble, clean, inspect, assemble, and install hoist drive motor control valve (para 17-21 for M977 and M985) (para 17-21.1 for M984E1).</p>		
<p>Step 4. Check for damaged hoist drive motor. Remove motor (para 17-22 for M977 and M985) (para 17-22.1 for M984E1). Do not disconnect hydraulic lines or hoist drive motor control valve. Operate crane (TM 9-2320-279-10). Operate HOIST control DOWN.</p>		
<p style="padding-left: 40px;">If motor does not turn or binds, remove lines, disassemble, clean, inspect, assemble, and install hoist drive motor (para 17-22 for M977 and M985) (para 17-22.1 for M984E1).</p>		

2-7. TROUBLESHOOTING INSTRUCTIONS (CONT).

Table 2-3. Troubleshooting (Cont)

Malfunction	Test or Inspection	Corrective Action
MATERIAL HANDLING CRANE (M977, M985, M984E1) (CONT)		
16. HOIST WILL NOT LOWER (CONT).		
<p>Step 5. Check for defective hoist assembly or hoist brake. Remove hoist drive motor (para 17-22 for M977 and M985) (para 17-22.1 for M984E1). Remove hoist brake (para 17-24 for M977 and M985) (para 17-24.1 for M984E1). Turn cable drum.</p>		
<p style="padding-left: 40px;">If drum binds or does not turn, repair hoist assembly (para 17-23).</p>		
<p style="padding-left: 40px;">If drum turns smoothly, repair hoist brake (para 17-24 for M977 and M985) (para 17-24.1 for M984E1).</p>		
<p>Step 6. Check if hoist lowers (TM 9-2320-279-10).</p>		
<p style="padding-left: 40px;">Repair hoist drive motor control valve (para 17-21 for M977 and M985) (para 17-21.1 for M984E1).</p>		
17. HOIST OPERATION SLOW WHEN LOWERING OR RAISING.		
<p>Step 1. Refer to HYDRAULIC SYSTEM troubleshooting.</p>		
<p style="padding-left: 40px;">If problem remains, go to step 2.</p>		
<p>Step 2. Check for damaged hoist lines.</p>		
<p style="padding-left: 40px;">Replace damaged hoist lines (para 17-2 for M977 and M985) (para 17-2.1 for M984E1).</p>		
<p>Step 3. Check hoist adjustment (para 17-25 for M977 and M985) (para 17-25.1 for M984E1). (Do only if difficulty is in raising.)</p>		
<p style="padding-left: 40px;">If pressure cannot be adjusted, replace hoist relief valve (para 17-28 for M977 and M985) (para 17-28.4 for M984E1).</p>		

Troubleshooting Malfunctions (Cont)
 Table 2-3. Troubleshooting (Cont)

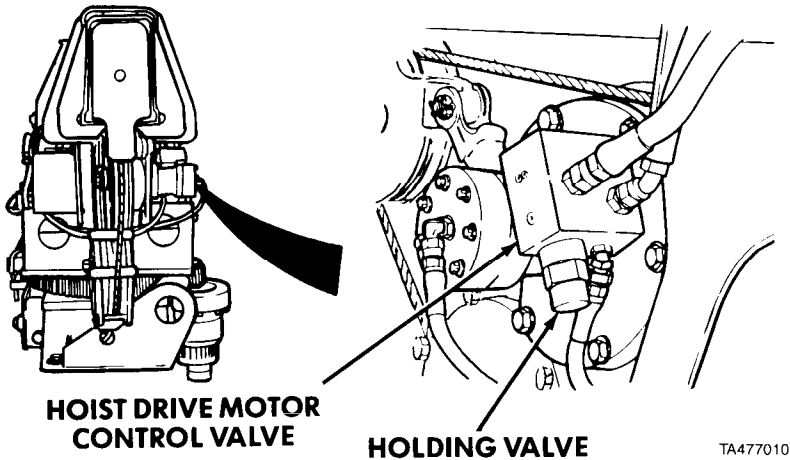
Malfunction	Test or Inspection	Corrective Action
MATERIAL HANDLING CRANE (M977, M985, M984E1) (CONT)		
17. HOIST OPERATION SLOW WHEN LOWERING OR RAISING (CONT).		
<p>Step 4. Check for defective hoist drive motor. Remove, disassemble, clean, inspect, assemble, and install hoist drive motor (para 17-22 for M977 and M985) (para 17-22.1 for M984E1).</p> <p>Step 5. Check for defective hoist brake. Remove hoist brake (para 17-24 for M977 and M985) (para 17-24.1 for M984E1). Turn cable drum. If drum turns smoothly, repair hoist brake (para 17-24 for M977 and M985) (para 17-24.1 for M984E1).</p>		
18. HOIST WILL NOT HOLD LOAD.		
<p>Step 1. Check for defective hoist brake. Remove, disassemble, clean, inspect, assemble, and install hoist brake (para 17-24 for M977 and M985) (para 17-24.1 for M984E1).</p>		
19. HOIST LOWERS LOAD TOO QUICKLY (LOAD DRIVES HOIST MOTOR).		
 <p style="text-align: center;"> HOIST DRIVE MOTOR CONTROL VALVE HOLDING VALVE TA477010 </p>		
<p>Step 1. Replace hoist drive motor control valve holding valve (para 17-21 for M977 and M985) (para 17-21.1 for M984E1).</p>		

2-7. TROUBLESHOOTING INSTRUCTIONS (CONT).

Table 2-3. Troubleshooting (Cont)

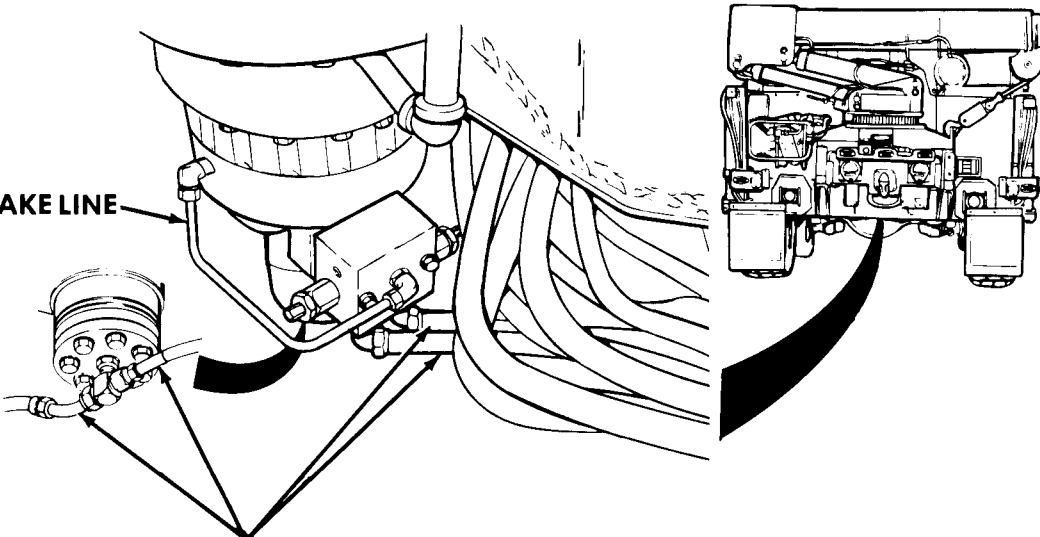
Malfunction	Test or Inspection	Corrective Action
MATERIAL HANDLING CRANE (M977, M985, M984E1) (CONT)		
20. SWING OPERATION SLOW OR ERRATIC IN BOTH DIRECTIONS.		
 <p data-bbox="151 772 495 802">SWING DRIVE BRAKE LINE</p> <p data-bbox="496 1123 760 1152">SWING DRIVE LINES</p> <p data-bbox="1341 1134 1409 1150">TA477011</p>		
<p>Step 1. Check for missing, loose, or improperly tightened swing drive motor attaching screws.</p>		
<p style="padding-left: 40px;">Replace missing or loose screws. Check swing drive motor attaching screws for correct tightness (para 17-7 for M977 and M985) (para 17-7.1 for M984E1).</p>		
<p>Step 2. Check for damaged swing drive brake line.</p>		
<p style="padding-left: 40px;">Replace damaged swing drive brake line (para 17-2 for M977 and M985) (para 17-2.1 for M984E1).</p>		
<p>Step 3. Check for damaged swing drive lines.</p>		
<p style="padding-left: 40px;">Replace damaged swing drive lines (para 17-2 for M977 and M985) (para 17-2.1 for M984E1).</p>		

Troubleshooting Malfunctions (Cont)

Table 2-3. Troubleshooting (Cont)

Malfunction	Test or Inspection	Corrective Action									
MATERIAL HANDLING CRANE (M977, M985, M984E1) (CONT)											
20. SWING OPERATION SLOW OR ERRATIC IN BOTH DIRECTIONS (CONT).											
Step 4.	Check for contaminated or damaged swing drive valves. Set up hydraulic pressure tester. Operate crane (TM 9-2320-279-10). Operate SWING control in both directions. Hydraulic pressure should be within the range shown when operated from turntable stop to turntable stop.	<table border="0"> <tr> <td>M977</td> <td>1600 psi (11 032 kPa) -</td> <td>1800 psi (12 411 kPa)</td> </tr> <tr> <td>M985</td> <td>1800 psi (12 411 kPa) -</td> <td>2000 psi (13 790 kPa)</td> </tr> <tr> <td>M984E1</td> <td>1400 psi (9 653 kPa) -</td> <td>1600 psi (11032 kPa)</td> </tr> </table>	M977	1600 psi (11 032 kPa) -	1800 psi (12 411 kPa)	M985	1800 psi (12 411 kPa) -	2000 psi (13 790 kPa)	M984E1	1400 psi (9 653 kPa) -	1600 psi (11032 kPa)
M977	1600 psi (11 032 kPa) -	1800 psi (12 411 kPa)									
M985	1800 psi (12 411 kPa) -	2000 psi (13 790 kPa)									
M984E1	1400 psi (9 653 kPa) -	1600 psi (11032 kPa)									
If pressure is outside of the range shown while at full swing, replace CW or CCW swing drive valve (para 17-6 for M977 and M985) (para 17-6.1 for M984E1).											
Step 5.	Check for defective turntable. Operate crane (TM 9-2320-279-10). Operate SWING control. Watch for any binding and listen for grinding or rumbling noise of turntable when swinging. Check for damage to swing drive gear or turntable bearing gear.	If binding or noisy, remove, clean, inspect, and install turntable and bearing (para 17-5 for M977 and M985) (para 17-5.1 for M984E1). If swing drive is damaged replace (para 17-9 for M977 and M985) (para 17-9.1 for M984E1).									

Troubleshooting Malfunctions (Cont)

2-7. TROUBLESHOOTING INSTRUCTIONS (CONT).

Table 2-3. Troubleshooting (Cont)

Malfunction	Test or Inspection	Corrective Action
MATERIAL HANDLING CRANE (M977, M985, M984E1) (CONT)		
20. SWING OPERATION SLOW OR ERRATIC IN BOTH DIRECTIONS (CONT).		
	Step 6. Check for contaminated swing directional control valve.	Remove, clean, inspect, and install directional control valve (para 17-28 for M977 and M985) (para 17-28.4 for M984E1).
	Step 7. Check for defective drive motor. Remove motor (para 17-7 for M977 and M985) (para 17-7.1 for M984E1), but do not remove swing drive valve body, swing drive valve hoses and tubes, or swing drive motor hydraulic hoses and tubes. Operate crane (TM 9-2320-279-10). Operate SWING control CW or CCW.	If motor binds or there are grinding or rumbling noises, disassemble, clean, inspect, assemble, and install swing drive motor (para 17-7 for M977 and M985) (para 17-7.1 for M984E1).
	Step 8. Check for defective swing drive brake.	Remove, disassemble, clean, inspect, assemble, and install swing drive brake (para 17-8 for M977 and M985) (para 17-8.1 for M984E1).
	Step 9. Check for defective swing drive.	Remove swing drive (para 17-9 for M977 and M985) (para 17-9.1 for M964E1). Turn swing drive pinion gear. If there is binding, disassemble, clean, inspect, assemble, and install swing drive (para 17-9 for M977 and M985) (para 17-9.1 for M984E1).

Troubleshooting Malfunctions (Cont)
 Table 2-3. troubleshooting (Cont)

Malfunction	Test or Inspection	Corrective Action
-------------	--------------------	-------------------

MATERIAL HANDLING CRANE (M977, M985, M984E1) (CONT)

21. SWING OPERATION ERRATIC OR SLOW IN ONE DIRECT ION ONLY.

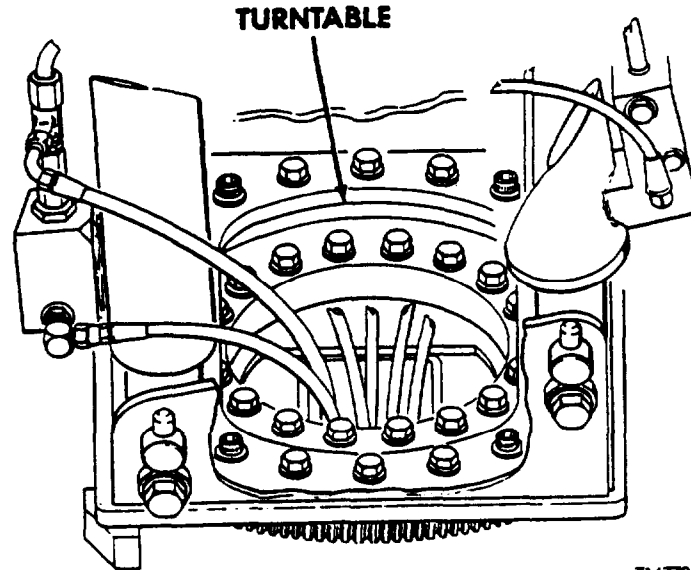

TA477013

Step 1. Check for defective turntable. Operate crane (TM 9-2320-279-10). Operate SWING control CW or CCW. Watch for any binding and listen for grinding or rumbling noise of turntable when swinging.

If binding or noisy, remove, clean, inspect, and install turntable and bearing (para 17-5 for M977 and M985) (para 17-5.1 for M984E1).

Troubleshooting Malfunctions (Cont)

2-7. TROUBLESHOOTING INSTRUCTIONS (CONT).

Table 2-3. Troubleshooting (Cont)

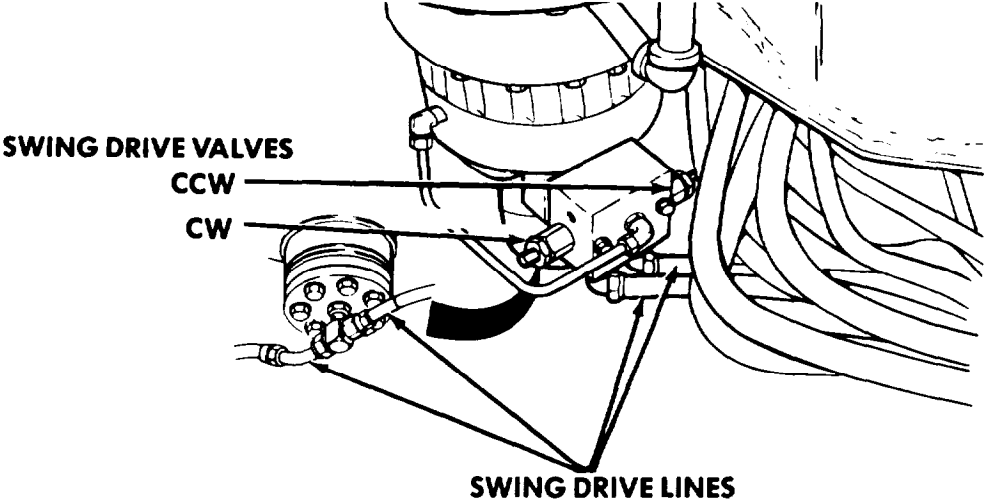
Malfunction	Test or Inspection	Corrective Action												
MATERIAL HANDLING CRANE (M977, M985, M984E1) (CONT)														
21. SWING OPERATION ERRATIC OR SLOW IN ONE DIRECTION ONLY (CONT).														
 <p>The diagram shows a close-up of the hydraulic swing drive mechanism. On the left, there are two valves labeled 'CCW' and 'CW'. Lines connect these valves to a central pivot point. Below the pivot, there are two lines labeled 'SWING DRIVE LINES'. The diagram is a technical line drawing showing the mechanical and hydraulic components of the crane's swing drive system.</p>														
Step 2.	Check for damaged swing drive lines.	Replace damaged swing drive lines (para 17-2 for M977 and M985) (para 17-2.1 for M984E1).												
Step 3.	Check for contamination or damaged swing drive valves. Set up hydraulic pressure tester. Operate crane (TM 9-2320-279-10). Operate SWING control in both directions. Hydraulic pressure should be within the range shown when operated from turntable stop to turntable stop.	<table border="0"> <tr> <td>M977</td> <td>1600 psi (11032 kPa)</td> <td>-</td> <td>1800 psi (12 411 kPa)</td> </tr> <tr> <td>M985</td> <td>1800 psi (12 411 kPa)</td> <td>-</td> <td>2000 psi (13 790 kPa)</td> </tr> <tr> <td>M984E1</td> <td>1400 psi (9 653 kPa)</td> <td>-</td> <td>1600 psi (11 032 kPa)</td> </tr> </table> <p>If pressure is outside of the range shown while at full swing, replace CW or CCW swing drive valve (para 17-6 for M977 and M985) (para 17-6.1 for M984E1).</p>	M977	1600 psi (11032 kPa)	-	1800 psi (12 411 kPa)	M985	1800 psi (12 411 kPa)	-	2000 psi (13 790 kPa)	M984E1	1400 psi (9 653 kPa)	-	1600 psi (11 032 kPa)
M977	1600 psi (11032 kPa)	-	1800 psi (12 411 kPa)											
M985	1800 psi (12 411 kPa)	-	2000 psi (13 790 kPa)											
M984E1	1400 psi (9 653 kPa)	-	1600 psi (11 032 kPa)											
Step 4.	Check for damaged swing drive.	Remove swing drive (para 17-9 for M977 and M985) (para 17-9.1 for M984E1). Turn switch drive pinion gear. If there is binding, disassemble, clean, inspect, assemble, and install swing drive (para 17-9 for M977 and M985) (para 17-9.1 for M984E1).												

Troubleshooting Malfunctions (Cont)
Table 2-3. Troubleshooting (Cont)

Malfunction	Test of Inspection	Corrective Action
MATERIAL HANDLING CRANE (M977, M985, M984E1) (CONT)		
21. SWING OPERATION ERRATIC OR SLOW IN ONE DIRECTION ONLY (CONT),		
	Step 5. Check for defective swing drive brake.	F&move, disassemble, clean, inspect, assemble, and install swing drive brake (para 17-8 for M977 and M985) (para 17-8.1 for M984E1).
	Step 6. Check for defective swing drive motor. Remove swing drive motor (para 17-7 for M977 and M985) (para 17-7.1 for M984E1). Do not remove swing drive valve body, swing drive valve hoses and tubes, or swing drive motor hydraulic hoses and tubes. Operate crane (TM 9-2320-279-10). Operate SWING control CW or CCW.	If motor binds or there are grinding or rumbling noises, disassemble, clean, inspect, assemble, and install swing drive motor (para 17-7 for M977 and M985) (para 17-7.1 for M984E1).
	Step 7. Check if swing operation is erratic or slow in one direction only.	Replace swing drive valves (para 17-6 for M977 and M985) (para 17-6.1 for M984E1).

Troubleshooting Malfunctions (Cont)

2-7. TROUBLESHOOTING INSTRUCTIONS (CONT).

Table 2-3. Troubleshooting (Cont)

Malfunction	Test or Inspection	Corrective Action									
MATERIAL HANDLING CRANE (M977, M985, M984E1) (CONT)											
22. SWING SYSTEM WILL NOT WORK.											
Step 1.	Check for damaged swing drive brake lines.	<p>Replace damaged swing drive brake line (para 17-2 for M977 and M985) (para 17-2. for M984E1).</p> <p style="text-align: center;"><u>CAUTION</u></p> <p>If crane rotates slowly or in one direction, slowly operate control lever to prevent damage to crane when it contacts rotational stop.</p>									
Step 2.	Check for contamination or damaged swing drive valves. Set up hydraulic pressure tester Operate crane (TM 9-2320-279-10). Operate SWING control in both directions. Hydraulic pressure should be within the range shown when operated from turntable stop to turntable stop.	<table border="0"> <tr> <td>M977</td> <td>1600 psi (11032 kPa) -</td> <td>1800 psi (12 411 kPa)</td> </tr> <tr> <td>M985</td> <td>1800 psi (12 411 kPa) -</td> <td>2000 psi (13 790 kPa)</td> </tr> <tr> <td>M984E1</td> <td>1400 psi (9 653 kPa) -</td> <td>1600 psi (11 032 kPa)</td> </tr> </table> <p>If pressure is outside of the range shown while at full swing, replace CW or CCW swing drive valve (para 17-6 for M977 and M985) (para 17-6.1 for M984E1).</p>	M977	1600 psi (11032 kPa) -	1800 psi (12 411 kPa)	M985	1800 psi (12 411 kPa) -	2000 psi (13 790 kPa)	M984E1	1400 psi (9 653 kPa) -	1600 psi (11 032 kPa)
M977	1600 psi (11032 kPa) -	1800 psi (12 411 kPa)									
M985	1800 psi (12 411 kPa) -	2000 psi (13 790 kPa)									
M984E1	1400 psi (9 653 kPa) -	1600 psi (11 032 kPa)									
Step 3.	Check for damaged swing drive lines.	<p>Replace damaged swing drive lines (para 17-2 for M977 and M985) (para 17-2.1 for M984E1).</p>									

Troubleshooting Malfunctions (Cont)

Table 2-3. Troubleshooting (Cont)

Malfunction	Test or Inspection	Corrective Action
MATERIAL HANDLING CRANE (M977, M985, M984E1) (CONT)		
22. SWING SYSTEM WILL NOT WORK (CONT).		
<p style="text-align: right;">TA356228</p>		
<p>Step 4. Check for defective swing drive motor. Remove motor (para 17-7 for M977 and M985) (para 17-7.1 for M984E1). Do not remove swing drive valve body, swing drive valve hoses and tubes, or swing drive motor hydraulic hoses and tubes. Operate crane (TM 9-2320-279-10). Operate SWING control CW or CCW.</p>		
<p style="padding-left: 40px;">If motor binds or there are grinding or rumbling noises, disassemble, clean, inspect, assemble, and install swing drive motor (para 17-7 for M977 and M985) (para 17-7.1 for M984E1).</p>		
<p>Step 5. Check for defective swing drive brake.</p>		
<p style="padding-left: 40px;">Remove, disassemble, clean, inspect, assemble, and install swing drive brake (para 17-8 for M977 and M985) (para 17-8.1 for M984E1).</p>		
<p>Step 6. Check for defective swing drive. Remove swing drive (para 17-9 for M977 and M985) (para 17-9.1 for M984E1). Turn swing drive pinion gear.</p>		
<p style="padding-left: 40px;">If there is binding, disassemble, clean, inspect, assemble, and install swing drive (para 17-9 for M977 and M985) (para 17-9.1 for M984E1).</p>		
<p>Step 7. Check if swing system works.</p>		
<p style="padding-left: 40px;">Replace swing drive valves (para 17-6 for M977 and M985) (para 17-6.1 for M984E1).</p>		

Troubleshooting Malfunctions (Cont)

2-7. TROUBLESHOOTING INSTRUCTIONS (CONT).

Table 2-3. Troubleshooting (Cont)

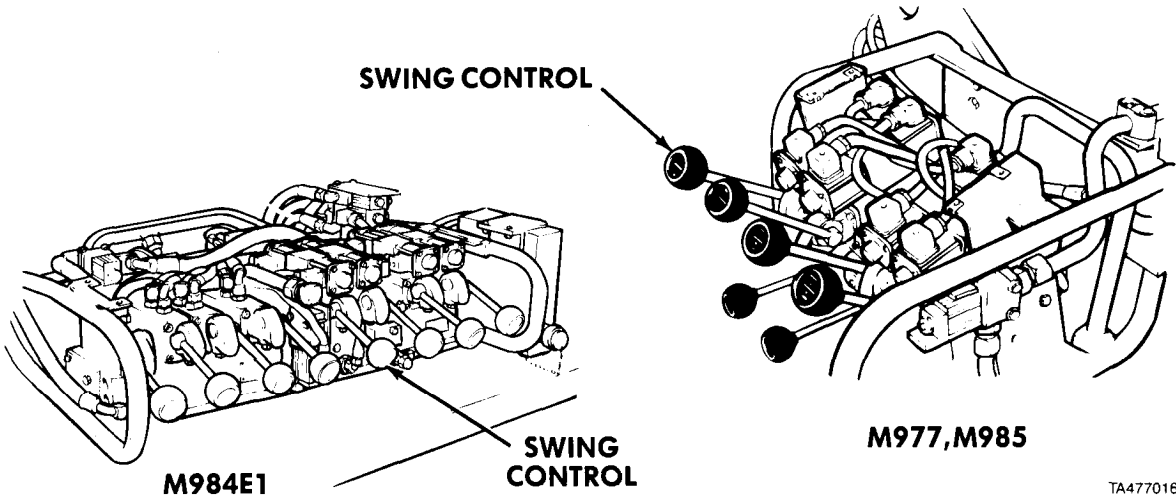
Malfunction	Test or Inspection	Corrective Action
MATERIAL HANDLING CRANE (M977, M985, M984E1) (CONT)		
23. SWING MOTOR CONTINUES TO OPERATE WHEN SWING CONTROL IS IN NEUTRAL POSITION.		
		
Step 1. Check for defective swing directional control spool valve.		
Remove, clean, inspect, and install swing directional control valve spool (para 17-28 for M977 and M985) (para 17-28.4 for M984E1).		

TA477016

Troubleshooting Malfunctions (Cont)

Table 2-3. Troubleshooting (Cont)

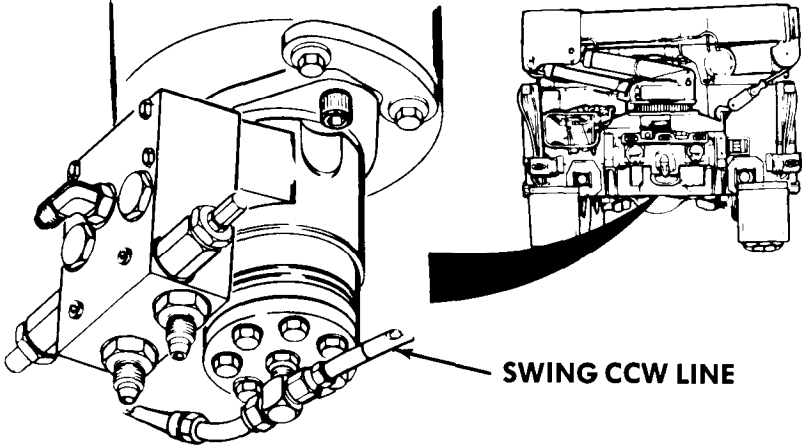
Malfunction	Test or Inspection	Corrective Action
MATERIAL HANDLING CRANE (M977, M985, M984E1) (CONT)		
24. SWING MOTOR NOISY.		
		
TA477017		
<p>Step 1. Check for air in swing system.</p>		
<p style="padding-left: 40px;">Disconnect swing CCW line. Operate crane (TM 9-2320-279-10). Operate SWING control CW and bleed air from swing system.</p>		
<p>Step 2. Check for defective swing drive motor. Remove swing drive motor (para 17-7 for M977 and M985) (para 17-7.1 for M984E1). Do not remove swing drive valve body, swing drive valve hoses and tubes, or swing drive motor hydraulic hoses and tubes. Operate crane (TM 9-2320-279-10). Operate SWING control CW or CCW.</p>		
<p style="padding-left: 40px;">If motor binds or there are grinding or rumbling noises, disassemble, clean, inspect, assemble, and install swing drive motor (para 17-7 for M977 and M985) (para 17-7.1 for M984E1).</p>		

Troubleshooting Malfunctions (Cont)

2-7. TROUBLESHOOTING INSTRUCTIONS (CONT.)

Table 2-3. Troubleshooting (Cont)

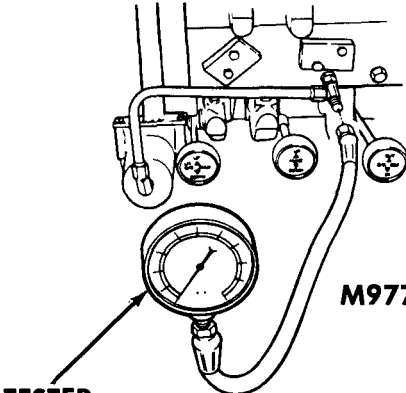
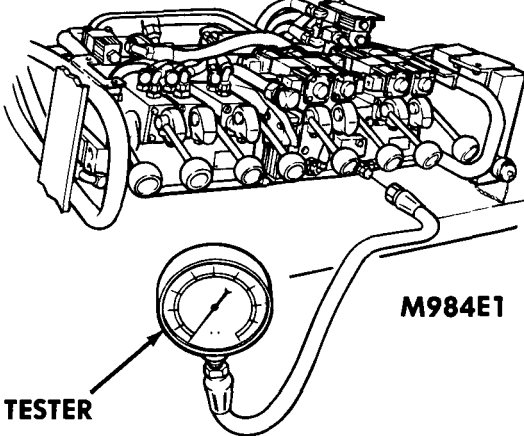
Malfunction	Test or Inspection	Corrective Action
MATERIAL HANDLING CRANE (M977, M985, M984E1) (CONT)		
25. CRANE CONTROLS STICKING OR CONTROL WILL NOT MOVE.		
 <p data-bbox="591 932 751 953" style="text-align: center;">M977,M985</p>	 <p data-bbox="1156 932 1263 953" style="text-align: center;">M984E1</p>	
TA477018		
<p>Step 1. Check for excessively high pressure in system. Set up hydraulic pressure tester on crane control valve. Operate crane (TM 9-2320-279-10).</p>		
<p style="padding-left: 40px;">If pressure is more than 3000 psi (20 685 kPa) when operating TELESCOPE OUT or LIFT UP controls, adjust main hydraulic pressure (para 17-31 for M977 and M985) (para 17-31.1 for M984E1).</p>		
<p>Step 2. Check for contaminated or damaged directional control spool valve.</p>		
<p style="padding-left: 40px;">Remove, clean, inspect, and install malfunctioning system directional control spool valve (para 17-28 for M977 and M985) (paras 17-28.3 and 17-28.4 for M984E1).</p>		

Troubleshooting Malfunctions (Cont)
 Table 2-3. Troubleshooting (Cont)

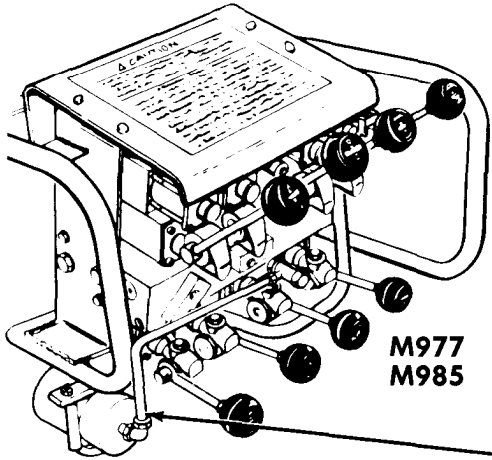
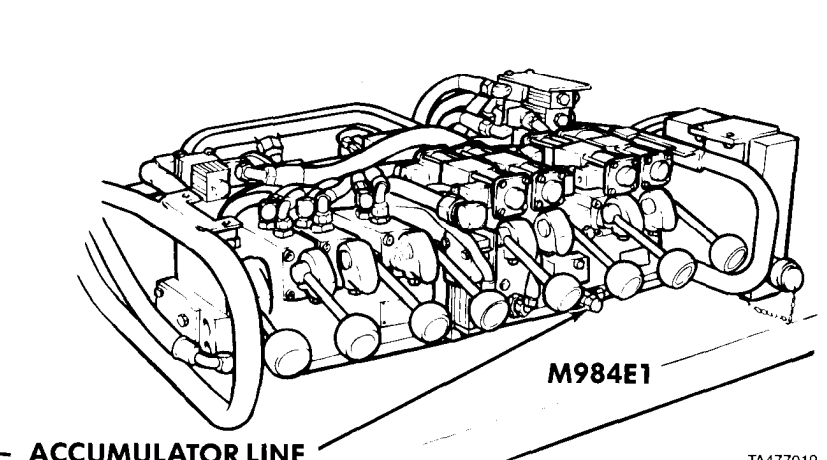
Malfunction Test or Inspection	Corrective Action
MATERIAL HANDLING CRANE (M977, M985, M984E1) (CONT)	
26. CRANE BOUNCES OR JERKS OR DOES NOT OPERATE SMOOTHLY WHEN CRANE CONTROLS ARE OPERATED OR RETURNED TO NEUTRAL.	
 <p>M977 M985</p>	 <p>M984E1</p> <p style="text-align: center;">ACCUMULATOR LINE</p>
<u>WARNING</u>	
<p>Accumulator is under 800 psi (5516 kPa) pressure. Removal of any parts without releasing pressure may cause personal injury or death.</p>	
<p>Step 1. Check for damaged or leaking accumulator hydraulic lines. Tighten accumulator connectors. Replace damaged accumulator line (para 17-30).</p> <p>Step 2. Check accumulator pressure with zero hydraulic pressure (para 17-30). If accumulator pressure is less than 800 psi (5 515 kPa), charge accumulator (para 17-30). If problem remains, or accumulator will not hold pressure, repair accumulator (para 17-30).</p> <p>Step 3. Check if crane does not stop operating when attempting to lift overload. If crane does not stop operating for six to nine seconds after overload sensors shut down crane, replace relay module (para 6-11 for M977 and M985) (para 6-11.1 for M984E1).</p>	

TA477019

Troubleshooting Malfunctions (Cont)

2-7. TROUBLESHOOTING INSTRUCTIONS (CONT).

Table 2-3. Troubleshooting (Cont)

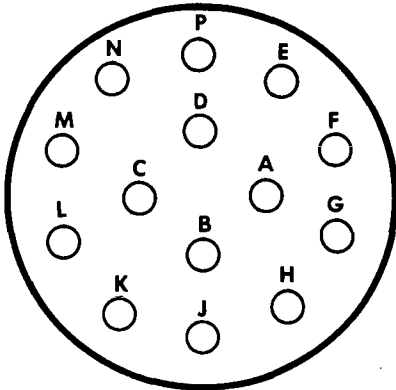
Malfunction	Test or Inspection	Corrective Action																																	
MATERIAL HANDLING CRANE (M977, M985, M984E1) (CONT)																																			
27. REMOTE CONTROLLER WILL NOT OPERATE CRANE IN ONE FUNCTION.																																			
Step 1. Refer to MALFUNCTION 1, CRANE WILL NOT OPERATE MANUALLY OR WITH REMOTE CONTROLLER, then go to step 2 if problem is not solved.																																			
	<table border="1"> <thead> <tr> <th data-bbox="773 804 822 834"><u>PIN</u></th> <th data-bbox="987 804 1125 834"><u>CONTROL</u></th> <th data-bbox="1212 804 1344 834"><u>WIRE NO.</u></th> </tr> </thead> <tbody> <tr> <td>A</td> <td>SWING CCW</td> <td>9</td> </tr> <tr> <td>B</td> <td>SWING CW</td> <td>10</td> </tr> <tr> <td>D</td> <td>TELE IN</td> <td>12</td> </tr> <tr> <td>C</td> <td>TELE OUT</td> <td>11</td> </tr> <tr> <td>M</td> <td>BOOM DOWN</td> <td>14</td> </tr> <tr> <td>N</td> <td>BOOM UP</td> <td>13</td> </tr> <tr> <td>G</td> <td>HOIST DOWN</td> <td>16</td> </tr> <tr> <td>F</td> <td>HOIST UP</td> <td>15</td> </tr> <tr> <td>H</td> <td>VEHICLE POWER</td> <td>4</td> </tr> <tr> <td>L</td> <td>VEHICLE GROUND</td> <td>2</td> </tr> </tbody> </table>	<u>PIN</u>	<u>CONTROL</u>	<u>WIRE NO.</u>	A	SWING CCW	9	B	SWING CW	10	D	TELE IN	12	C	TELE OUT	11	M	BOOM DOWN	14	N	BOOM UP	13	G	HOIST DOWN	16	F	HOIST UP	15	H	VEHICLE POWER	4	L	VEHICLE GROUND	2	
<u>PIN</u>	<u>CONTROL</u>	<u>WIRE NO.</u>																																	
A	SWING CCW	9																																	
B	SWING CW	10																																	
D	TELE IN	12																																	
C	TELE OUT	11																																	
M	BOOM DOWN	14																																	
N	BOOM UP	13																																	
G	HOIST DOWN	16																																	
F	HOIST UP	15																																	
H	VEHICLE POWER	4																																	
L	VEHICLE GROUND	2																																	
JUNCTION BOX REMOTE CONTROLLER CONNECTOR																																			
TA477020																																			
Step 2. Check for defective junction box remote control wiring. Set ENGINE, PTO ENGAGE, and crane POWER switches to ON. Place negative (-) multimeter probe on defective function control pin and positive (+) probe on pin H. As control pin is touched, meter should show 24 to 30 vdc.																																			
NOTE																																			
<ul style="list-style-type: none"> To remove junction box cover on M984E1, two screws, lockwashers, and nuts must be removed from junction box and mounting bracket and box positioned on top of 4-valve bank assembly. If no voltage, remove junction box cover (para 6-11 for M977 and M985) (para 6-11.1 for M984E1) and repair defective function control wire (FO-4, M977, M985, and M984E1 Crane Wiring Diagram). 																																			

Troubleshooting Malfunctions (Cont)
 Table 2-3. Troubleshooting (Cont)

Malfunction Test or Inspection	Corrective Action
MATERIAL HANDLING CRANE (M977, M985, M984E1) (CONT)	
27. REMOTE CONTROLLER WILL NOT OPERATE CRANE IN ONE FUNCTION (CONT).	
<p>The diagram illustrates the electrical circuit for a remote controller malfunction. It shows three main components: the crane engine (M977, M985) at the bottom, the remote controller (M984E1) at the top right, and a junction box (M977, M985) at the bottom right. A central circular terminal block contains 14 pins labeled A through N. Terminal No. 1 is connected to pin A, and Terminal No. 2 is connected to pin N. A 'DANGER' warning label is also shown on the junction box.</p>	
<p>Step 3. Remove connector from defective function solenoid. Check for defective connector or cable module. Check wire resistance between connector terminal No. 2 and vehicle ground. Check wire resistance between connector terminal No. 1 and defective function pin on junction box remote control connector.</p>	<p>If wire resistance is more than zero ohms, check connector to be sure connections are tight and that wires are not broken. Replace cable module if wires are broken (para 6-11 for M977 and M985) (para 6-11.1 for M984E1).</p>

TA477021

Troubleshooting Malfunctions (Cont)

2-7. TROUBLESHOOTING INSTRUCTIONS (CONT).

Table 2-3. Troubleshooting (Cont)

Malfunction	Test or Inspection	Corrective Action
MATERIAL HANDLING CRANE (M977, M985, M984E1) (CONT)		
27. REMOTE CONTROLLER WILL NOT OEPRATE CRANE IN ONE FUNCTION (CONT).		
	<p>Step 4. Check for defective function solenoid. Set ENGINE, PTO ENGAGE, and crane POWER switches to ON. Operate suspected defective function control on remote controller. Listen for clicking sound of solenoid to tell if it operates.</p>	<p>Replace defective solenoid (para 17-29 for M977 and M985) (para 17-29.1 for M984E1).</p>
	<p>Step 5. Check for defective function control pilot valve. Remove function control pilot valve (para 17-28 for M977 and M985) (paras 17-28.3 and 17-28.4 for M984E1).</p>	<p>Clean, inspect, and install pilot valve (para 17-28 for M977 and M985) (paras 17-28.3 and 17-28.4 for M984E1).</p>

Troubleshooting Malfunctions (Cont)
 Table 2-3. Troubleshooting (Cont)

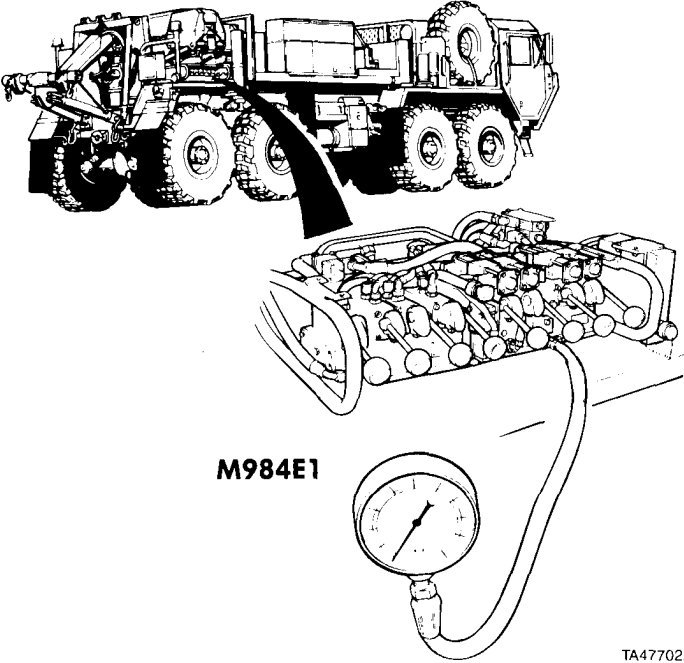
Malfunction	Test or Inspection	Corrective Action
RETRIEVAL SYSTEM		
NOTE		
<p>Before performing hydraulic tests, the hydraulic oil reservoir must be at least warm to the touch.</p>		
<ol style="list-style-type: none"> 1. LIFT CYLINDER WILL NOT LIFT LOAD. 2. LIFT CYLINDER WILL NOT EXTEND. 3. TOW CYLINDER WILL NOT EXTEND. 4. TOW CYLINDER WILL NOT RETRACT. 		
<p>Step 1. Operate crane (TM 9-2320-279-10). If crane works, go to Step 2. If crane does not work, refer to Hydraulic System Troubleshooting.</p>		
 <p>The diagram illustrates the hydraulic system for a truck-mounted crane. It shows a side view of the truck with the crane mounted on the back. A thick black arrow points from the crane's hydraulic system to a detailed cutaway view of the engine and hydraulic pump area. In this detailed view, a pressure gauge is connected to a test port. The gauge is labeled 'M984E1'. The gauge has a circular face with a needle and numerical markings. Below the gauge, the part number 'TA477022' is printed.</p>		
<p>Step 2. Check for defective main relief valve. Install pressure gauge on test port of eight valve bank. Operate MAST down and read pressure gauge. If pressure is 3000 psi (20 068 kPa) \pm 200 (1 379 kPa) go to Step 3. If pressure is not 3000 psi (20 068 kPa) \pm 200 (1 379 kPa) adjust main relief (para 17-31.1).</p>		

2-7. TROUBLESHOOTING INSTRUCTIONS (CONT).

Table 2-3. Troubleshooting (Cont)

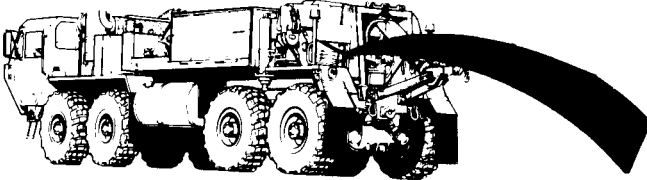
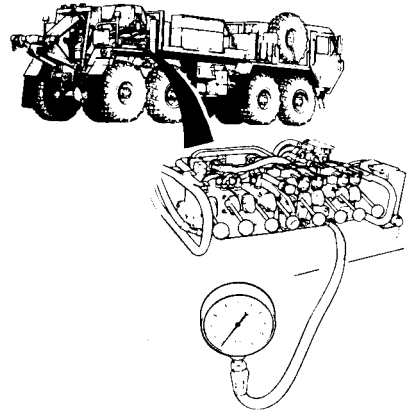
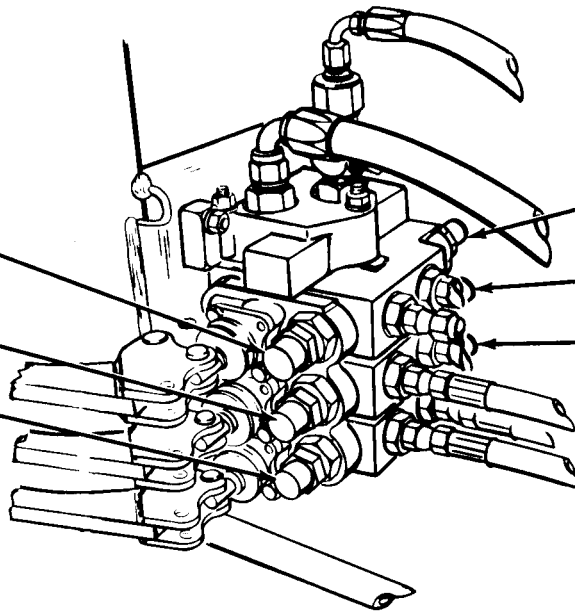
Malfunction	Test or Inspection	Corrective Action
RETRIEVAL SYSTEM (CONT)		
<ol style="list-style-type: none"> 1. LIFT CYLINDER WILL NOT LIFT LOAD (CONT). 2. LIFT CYLINDER WILL NOT EXTEND (CONT). 3. TOW CYLINDER WILL NOT EXTEND (CONT). 4. TOW CYLINDER WILL NOT RETRACT (CONT). 		
<div style="display: flex; justify-content: space-between;"> <div style="width: 45%;">  </div> <div style="width: 45%;">  </div> </div> <div style="text-align: center; margin-top: 20px;">  </div> <div style="display: flex; justify-content: space-between; margin-top: 10px;"> <div style="width: 45%;"> <p>RIGHT TOW CYLINDER EXTEND</p> <p>LEFT TOW CYLINDER EXTEND</p> <p>LIFT CYLINDER EXTEND</p> </div> <div style="width: 45%;"> <p>RIGHT TOW CYLINDER RETRACT</p> <p>LEFT TOW CYLINDER RETRACT</p> <p>LIFT CYLINDER RETRACT</p> </div> </div>		
TA477023		

Troubleshooting Malfunctions (Cont)
table 2-3. Troubleshooting (Cont)

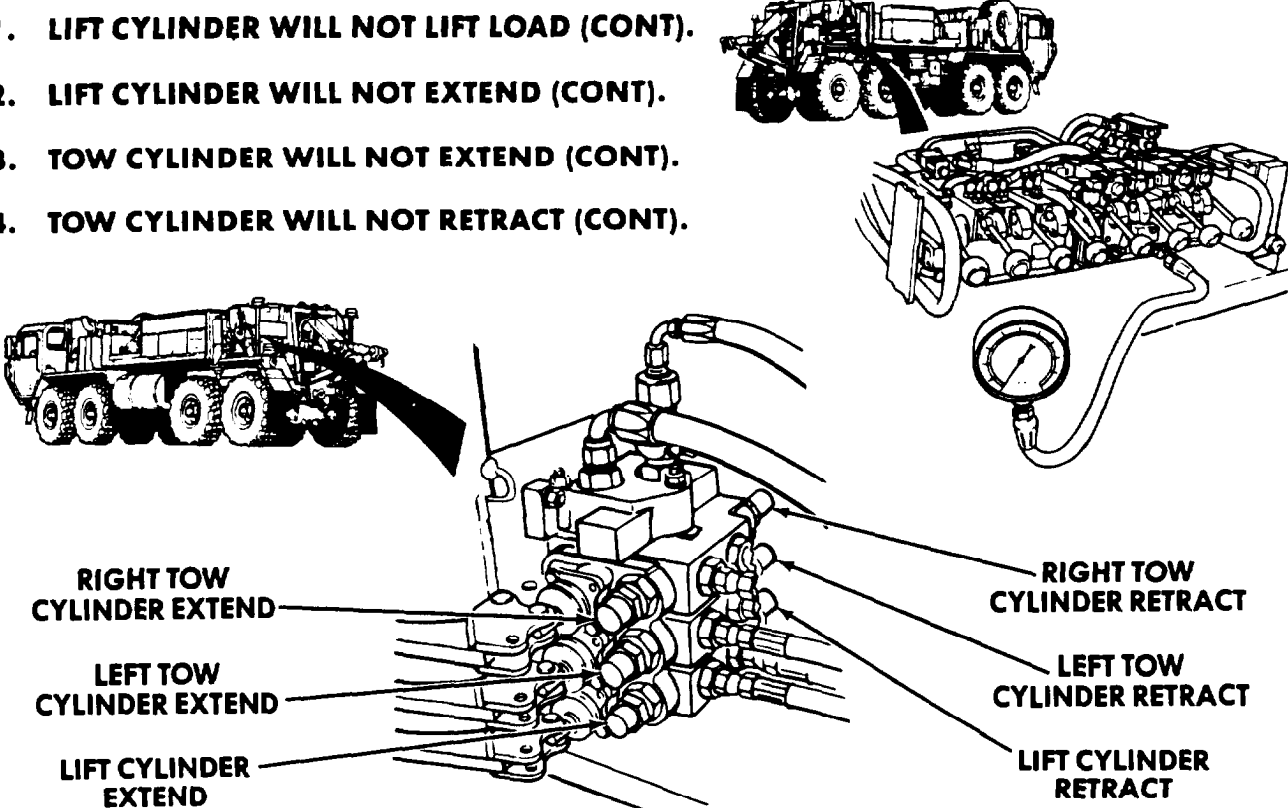
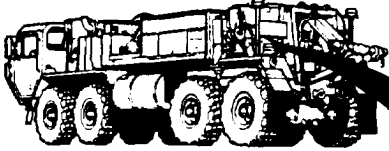
Malfunction	Test or Inspection	Corrective Action
RETRIEVAL SYSTEM (CONT)		
1. LIFT CYLINDER WILL NOT LIFT LOAD (CONT).		
2. LIFT CYLINDER WILL NOT EXTEND (CONT).		
3. TOW CYLINDER WILL NOT EXTEND (CONT).		
4. TOW CYLINDER WILL NOT RETRACT (CONT).		
		
	RIGHT TOW CYLINDER EXTEND	RIGHT TOW CYLINDER RETRACT
	LEFT TOW CYLINDER EXTEND	LEFT TOW CYLINDER RETRACT
	LIFT CYLINDER EXTEND	LIFT CYLINDER RETRACT
	NOTE	TA477023
	Test procedures for all retrieval cylinders are the same.	
	Step 3. Check for defective cylinders or holding valves. Install pressure gauge on test port on eight valve bank. Operate cylinder in direction it will not work until relief valve engages (TM 9-2320-279-10).	
	If pressure is correct, remove holding valves from cylinder and check for damage or clogging.	
	Lift cylinder - Extend - 400 psi (2 758 kPa) (para 13-30.2) - Retract - 2500 psi (17 238 kPa)	
	Tow cylinders- Extend - 300 psi (2 069 kPa) (para 13-30.4) - Retract - 300 psi (2 069 kPa)	
	If holding valves are good, repair hydraulic cylinder (para 13-30.3 and 13-30.5).	
	If pressure is not correct, replace relief valve for cylinder in the direction it does not work correctly.	
	If cylinder is still inoperative, replace or repair control valve.	

Troubleshooting Malfunctions (Cont)

2-7. TROUBLESHOOTING INSTRUCTIONS (CONT).

Table 2-3. Troubleshooting (Cont)

Malfunction	Test or Inspection	Corrective Action
-------------	--------------------	-------------------

ARCTIC HEATER KIT (CONT)

WARNING

Do not wear jewelry when working around the vehicle. Jewelry can catch on equipment and cause injury, or may short across an electrical circuit and cause severe burns or electrical shock.

1. COOLANT PUMP FAILS TO OPERATE (INDICATOR LIGHT COMES ON) (MODEL A).

Check for defective coolant pump.

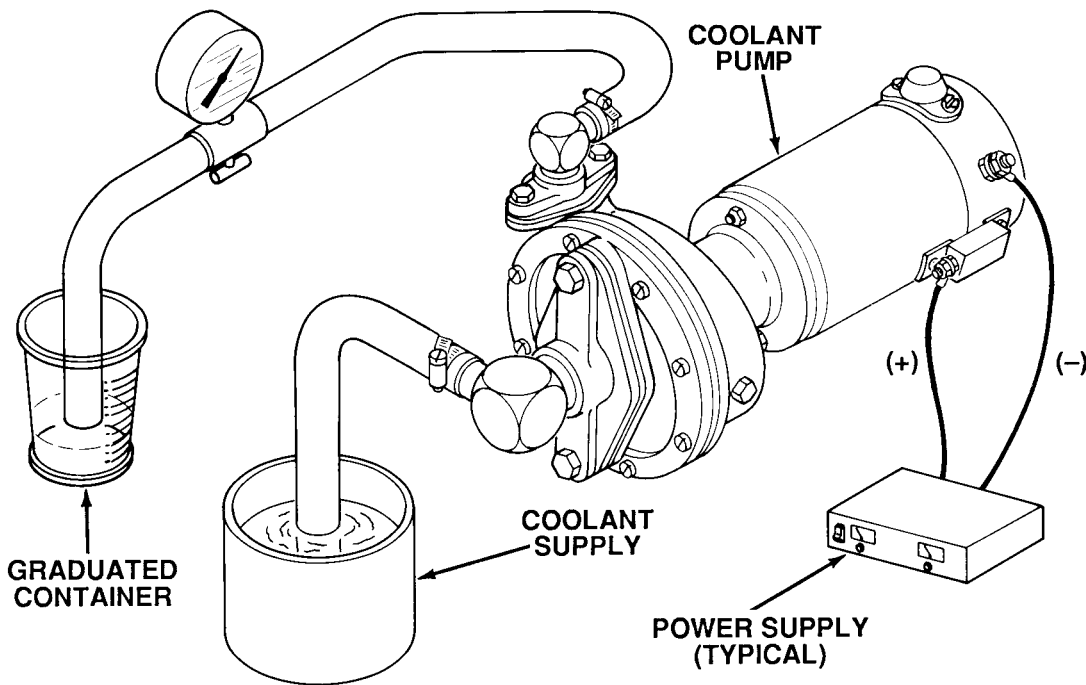

Figure 2-9. Arctic Coolant Pump Test

Remove coolant pump assembly (TM 9-2320-279-20) and mount pump assembly on bench. Set up coolant pump test (fig. 2-9). Apply 24 vdc power to input terminal and ground negative (-) to terminal on pump body. Let motor run 15 minutes.

If coolant does not flow at a rate of 16.0 GPM (60.5 liters/min) or pump operation is not smooth and there is more than one cc/hr leakage from seal, repair or replace coolant pump (para 21-2).

Troubleshooting Malfunctions (Cont)



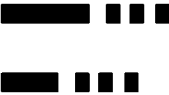













Table 2-3. Troubleshooting (Cont)

Malfunction	Test or Inspection	Corrective Action
ARCTIC HEATER KIT		
2. ARCTIC HEATER DIAGNOSTIC TROUBLESHOOTING (DIRECT LEVEL) (MODEL B).		
NOTE		
<ul style="list-style-type: none"> • If the Fault Code Retrieval Device (FCRD) is not installed, the arctic heater indicator light displays the diagnostic flash codes for the arctic heater. These flash codes are eight seconds long and repeat after eight seconds. • The Fault Code Retrieval Device (FCRD) displays the last five faults that occur. The latest fault is displayed with either “AF” or “F1”. If more than one fault code is displayed, troubleshoot the latest fault code first. • All organizational level troubleshooting must be completed before performing this procedure. • Refer to arctic engine heater (Model B) troubleshooting (TM 9-2320-279-20) for Fault Code Retrieval Device (FCRD) operations. 		
Step 1.	<p>Using the Fault Code Retrieval Device (FCRD) or the arctic heater indicator light, determine which fault code is active from the list shown on Figure 2-10.</p> <p style="padding-left: 40px;">If fault code 000 is displayed and arctic heater does not operate, replace arctic heater control unit (para 21-3) and go to Step 50.</p> <p style="padding-left: 40px;">If a fault code other than 000 is displayed, go to the step indicated in the list shown.</p>	

Troubleshooting Malfunctions (Cont)

2-7. TROUBLESHOOTING INSTRUCTIONS (CONT).

Table 2-3. Troubleshooting (Cont)

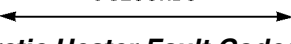
Malfunction Test or Inspection	Corrective Action
ARCTIC HEATER KIT (CONT)	
2. ARCTIC HEATER DIAGNOSTIC TROUBLESHOOTING (DIRECT LEVEL) (MODEL B) (CONT).	
FAULT FLASH CODE	
CODE 000	
CODE 090, 093, 094, OR 097	 GO TO STEP 49
CODE 050, OR 052	 GO TO STEP 25
CODE 010	 GO TO STEP 49
CODE 011	 GO TO STEP 49
CODE 033	 GO TO STEP 16
CODE 001, OR 002	 GO TO STEP 49
CODE 043, 047, OR 048	 GO TO STEP 49
CODE 064, OR 065	 GO TO STEP 39
CODE 060, 061, 071, OR 072	 GO TO STEP 45
CODE 012, 013, 014, OR 015	 GO TO STEP 2
CODE 037, 042, OR 059	 GO TO STEP 22
CODE 020, OR 021	 GO TO STEP 9
CODE 053, 054, 055, OR 056	  GO TO STEP 42
CODE 051	 GO TO STEP 39
	
Figure 2-10. Arctic Heater Fault Codes (Model B)	

Troubleshooting Malfunctions (Cont)

Table 2-3. Troubleshooting (Cont)

Malfunction	Test or Inspection	Corrective Action
ARCTIC HEATER KIT		
2. ARCTIC HEATER DIAGNOSTIC TROUBLESHOOTING (DIRECT LEVEL) (MODEL B) (CONT).		
NOTE		
Steps (2) through (8) are for fault codes 012, 013, 014 or 015.		
Step 2.	Remove arctic heater control unit (para 21-3).	
Step 3.	Perform resistance check across arctic heater temperature sensor at room temperature (-13° to 77°F [-25° to 25°C]). Connect probes across arctic heater internal harness connector terminals No. 14 and 18.	If resistance reading is not between 650 and 1000 ohms, replace arctic heater temperature sensor (para 21-3) and go Step 6.
<p>The diagram illustrates the Arctic Heater Kit components and their electrical connections. On the left, the Arctic Heater Control Unit is shown with a screw being inserted into its top. Below it, the Arctic Heater is shown with the control unit removed. Two sensors are identified: the Arctic Heater Overheat Sensor and the Arctic Heater Temperature Sensor. To the right, a terminal block is shown with a 3x6 grid of terminals. Arrows indicate the following connections: Terminal 14 to Terminal 13; Terminal 11 to Terminal 10; Terminal 16 to Terminal 16; Terminal 17 to Terminal 17; Terminal 18 to Terminal 18; and Terminal 15 to Terminal 15.</p>		
Step 4.	Perform resistance check across arctic overheat sensor at room temperature (-13° to 77°F [-25° to 25°C]). Connect probes across arctic heater internal harness connector terminals No. 11 and 17.	If resistance reading is not between 10k and 150k ohms, replace arctic heater overheat sensor (para 21-3) and go Step 6.

Troubleshooting Malfunctions (Cont)

2-7. TROUBLESHOOTING INSTRUCTIONS (CONT).

Table 2-3. Troubleshooting (Cont)

Malfunction	Test or Inspection	Corrective Action
-------------	--------------------	-------------------

ARCTIC HEATER KIT (CONT)

2. ARCTIC HEATER DIAGNOSTIC TROUBLESHOOTING (DIRECT LEVEL) (MODEL B) (CONT).

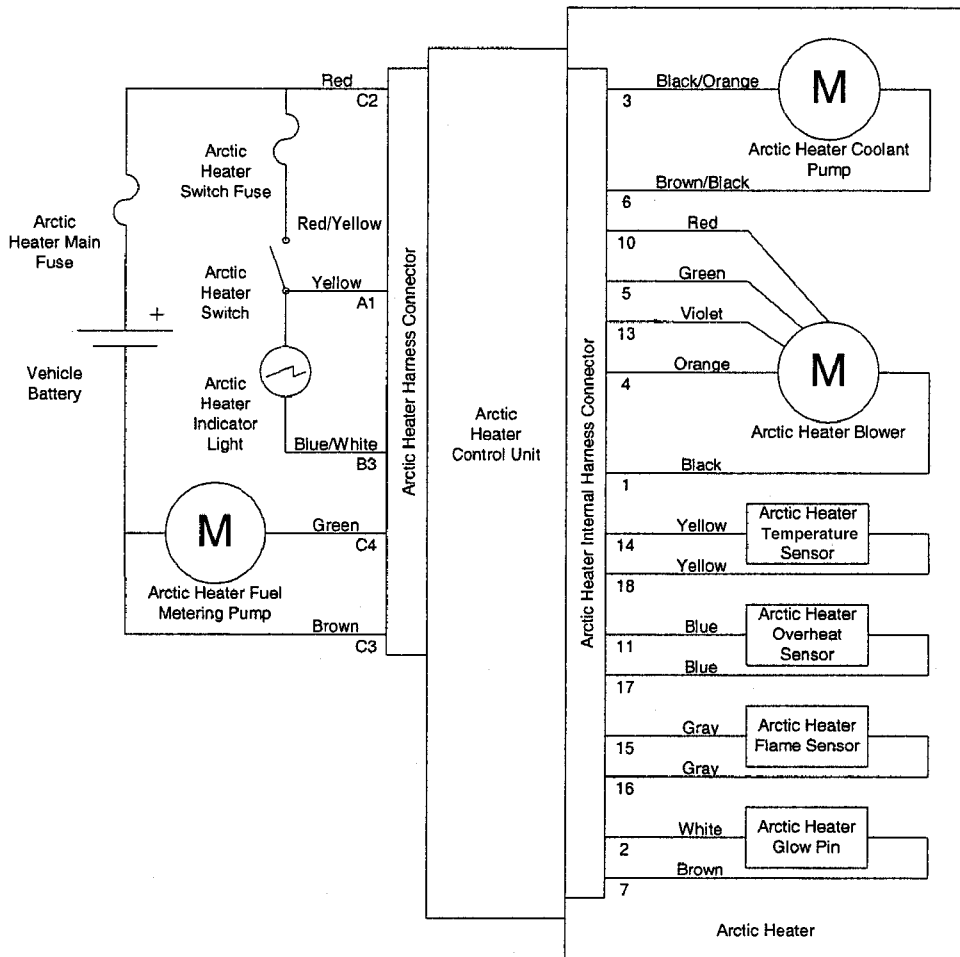

Figure 2-11. Arctic Heater Kit Wiring Diagram (Model B)

Troubleshooting Malfunctions (Cont)

Table 2-3. Troubleshooting (Cont)

Malfunction	Test or Inspection	Corrective Action
ARCTIC HEATER KIT		
2. ARCTIC HEATER DIAGNOSTIC TROUBLESHOOTING (DIRECT LEVEL) (MODEL B) (CONT).		
Step 5.	Perform resistance check across arctic heater flame sensor at room temperature (-13° to 77°F [-25° to 25°C]). Connect probes across arctic heater internal connector terminals No. 15 and 16.	<p>If resistance reading is between 900 and 1100 ohms, replace arctic heater coolant pump (para 21-3).</p> <p>If resistance reading is not between 900 and 1100 ohms, replace arctic heater flame sensor (para 21-3).</p>
Step 6.	Check if arctic heater operates.	If arctic heater operates, go to Step 50.
Step 7.	If Fault Code Retrieval Device (FCRD) is available, clear fault code 015 and go to Step 50.	
Step 8.	If Fault Code Retrieval Device (FCRD) is not available, replace arctic heater control unit (para 21-3) and go to Step 50.	
NOTE		
<ul style="list-style-type: none"> • Steps (9) through (15) are for fault codes 020 or 021. • Arctic heater glow pin harness white and brown wires are connected with a seal. Do not separate white and brown wire from seal at glow pin terminal. 		
Step 9.	Remove arctic heater control unit (para 21-3).	
Step 10.	Disconnect arctic heater glow pin harness from arctic heater glow pin (para 21-3).	
Step 11.	Perform continuity check on arctic heater glow pin harness white wire. Connect probes at arctic heater internal harness connector, terminal No. 2 and glow pin harness white wire terminal.	If continuity is not present, replace arctic heater glow pin harness (para 21-3) and go to Step 50.

Troubleshooting Malfunctions (Cont)

2-7. TROUBLESHOOTING INSTRUCTIONS (CONT).

Table 2-3. Troubleshooting (Cont)

Malfunction	Test or Inspection	Corrective Action
ARCTIC HEATER KIT (CONT)		
2. ARCTIC HEATER DIAGNOSTIC TROUBLESHOOTING (DIRECT LEVEL) (MODEL B) (CONT).		
	<p>Step 12. Perform continuity check on arctic heater glow pin harness brown wire. Connect probes at arctic heater internal harness connector, terminal No. 7 and glow pin harness brown wire terminal.</p> <p style="padding-left: 40px;">If continuity is not present, replace arctic heater glow pin harness (para 21-3) and go to Step 50.</p> <p>Step 13. Perform continuity check on arctic heater glow pin harness wires. Connect probes to arctic heater internal harness connector terminals No. 2 and 7. Check for shorts between brown and white wires.</p> <p style="padding-left: 40px;">If continuity is measured, replace arctic heater glow pin harness (para 21-3) and go to Step 50.</p> <p>Step 14. Perform resistance check across arctic glow pin. Connect probes at arctic heater glow pin top and bottom terminals. Resistance should be 2 ohms (nominal).</p> <p style="padding-left: 40px;">If resistance reading of 2 ohms (nominal) is present, replace arctic heater control unit (para 21-3).</p> <p style="padding-left: 40px;">If resistance reading of 2 ohms (nominal) is not present, replace arctic heater glow pin.</p> <p>Step 15. Go to Step 50.</p>	

Troubleshooting Malfunctions (Cont)

Table 2-3. Troubleshooting (Cont)

Malfunction	Test or Inspection	Corrective Action																		
ARCTIC HEATER KIT																				
2. ARCTIC HEATER DIAGNOSTIC TROUBLESHOOTING (DIRECT LEVEL) (MODEL B) (CONT).																				
NOTE																				
Steps (16) through (21) are for fault code 033.																				
Step 16. Remove arctic heater control unit (para 21-3).																				
Step 17. Check operation of arctic heater blower by connecting an external 24 vdc power supply to the arctic heater internal harness connector. Place positive (+) lead at terminal No. 4. Place negative (-) lead at terminal No. 1.																				
If blower motor does not operate, replace arctic heater blower (para 21-3) and go to Step 50.																				
<p>The diagram illustrates the diagnostic setup for the Arctic Heater Blower. It shows the Arctic Heater Control Unit being removed from the blower assembly. A terminal block with 18 terminals is shown, with terminal 4 labeled 'TERMINAL 4' and terminal 1 labeled 'TERMINAL 1'. The terminals are arranged in a 3x6 grid:</p> <table border="1" data-bbox="922 1010 1354 1272"> <tr> <td>16</td> <td>13</td> <td>10</td> <td>7</td> <td>4</td> <td>1</td> </tr> <tr> <td>17</td> <td>14</td> <td>11</td> <td>8</td> <td>5</td> <td>2</td> </tr> <tr> <td>18</td> <td>15</td> <td>12</td> <td>9</td> <td>6</td> <td>3</td> </tr> </table>			16	13	10	7	4	1	17	14	11	8	5	2	18	15	12	9	6	3
16	13	10	7	4	1															
17	14	11	8	5	2															
18	15	12	9	6	3															

Troubleshooting Malfunctions (Cont)

2-7. TROUBLESHOOTING INSTRUCTIONS (CONT).

Table 2-3. Troubleshooting (Cont)

Malfunction	Test or Inspection	Corrective Action
ARCTIC HEATER KIT (CONT)		
2. ARCTIC HEATER DIAGNOSTIC TROUBLESHOOTING (DIRECT LEVEL) (MODEL B) (CONT).		
	<p>Step 18. Connect arctic heater harness connector to arctic heater control unit (para 21-3).</p> <p>Step 19. Check voltage at arctic heater control unit internal connector. Place positive (+) probe at terminal No. 10. Place negative (-) probe at terminal No. 5. Turn arctic heater switch on. Voltage should be 5 vdc (nominal).</p> <p style="padding-left: 40px;">If voltage reading of 5 vdc (nominal) is not present, replace arctic heater control unit (para 21-3) and go to Step 50.</p>	

Troubleshooting Malfunctions (Cont)

Table 2-3. Troubleshooting (Cont)

Malfunction	Test or Inspection	Corrective Action
ARCTIC HEATER KIT		
2. ARCTIC HEATER DIAGNOSTIC TROUBLESHOOTING (DIRECT LEVEL) (MODEL B) (CONT).		
<p style="text-align: center;">(REAR VIEW ARCTIC HEATER INTERNAL HARNESS CONNECTOR)</p>		
Step 20.	Check voltage at internal harness connector when blower is turned on. Connect arctic heater internal harness connector to arctic heater control unit. Back probe arctic heater internal harness connector. Place positive (+) probe at terminal No. 13. Place negative (-) probe at terminal No. 5. Turn arctic heater switch on. Voltage should be 2.2 to 2.8 vdc.	<p>If voltage reading of 2.2 to 2.8 vdc is present, replace arctic heater control unit (para 21-3).</p> <p>If voltage reading of 2.2 to 2.8 is not present, replace arctic heater blower (para 21-3).</p>
Step 21.	Go to Step 50.	

Troubleshooting Malfunctions (Cont)

2-7. TROUBLESHOOTING INSTRUCTIONS (CONT).

Table 2-3. Troubleshooting (Cont)

Malfunction	Test or Inspection	Corrective Action
ARCTIC HEATER KIT (CONT)		
2. ARCTIC HEATER DIAGNOSTIC TROUBLESHOOTING (DIRECT LEVEL) (MODEL B) (CONT).		
NOTE		
Steps (22) through (24) are for fault codes 037, 042 or 059.		
Step 22.	Remove arctic heater control unit (para 21-3).	
Step 23.	Perform resistance check across arctic heater temperature sensor at room temperature (-13° to 77° F [-25° to 25° C]). Connect probes across arctic heater internal harness connector terminals No. 14 and 18.	
	If resistance reading is between 650 and 1000 ohms, replace arctic heater coolant pump (para 21-3).	
	If resistance reading is not between 650 and 1000 ohms, replace arctic heater temperature sensor (para 21-3).	
Step 24.	Go to Step 50.	

Troubleshooting Malfunctions (Cont)

Table 2-3. Troubleshooting (Cont)

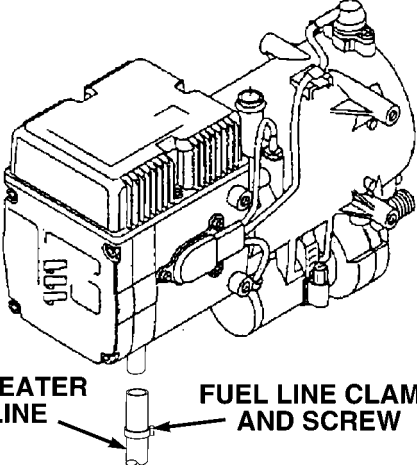
Malfunction	Test or Inspection	Corrective Action
ARCTIC HEATER KIT		
2. ARCTIC HEATER DIAGNOSTIC TROUBLESHOOTING (DIRECT LEVEL) (MODEL B) (CONT).		
		
NOTE		
Steps (25) through (38) are for fault codes 050 or 052.		
Step 25.	Check if arctic heater operates.	If arctic heater operates, go to step 29.
Step 26.	If Fault Code Retrieval Device (FCRD) is available, clear fault code 050 and go to Step 28.	
Step 27.	Replace arctic heater control unit (para 21-3).	
Step 28.	Perform fuel metering pump quantity test.	
	a. Disconnect fuel line from arctic heater and place in graduated 1 quart (950 ml) measuring container.	
	b. Turn arctic heater switch on.	
	c. Observe fuel delivery. Fuel metering pump will start approximately 63 seconds after arctic heater switch is turned on. Stop 105 seconds after the switch is turned on and restart 180 seconds after the switch is turned on.	
	d. When fuel metering pump stops after the second restart, turn arctic heater switch off.	
	e. Reconnect fuel line to arctic heater.	
	f. Measure fuel delivered.	
	If arctic heater does not operate, go to Step 26.	
	If no fuel is delivered and audible clicking is heard from fuel metering pump, go to Step 32.	
	If arctic heater fuel metering pump delivers less than 0.62 ounces (18.64 ml) of fuel, replace arctic heater fuel metering pump (TM 9-2320-279-20-3) and go to Step 36.	

Troubleshooting Malfunctions (Cont)

2-7. TROUBLESHOOTING INSTRUCTIONS (CONT).

Table 2-3. Troubleshooting (Cont)

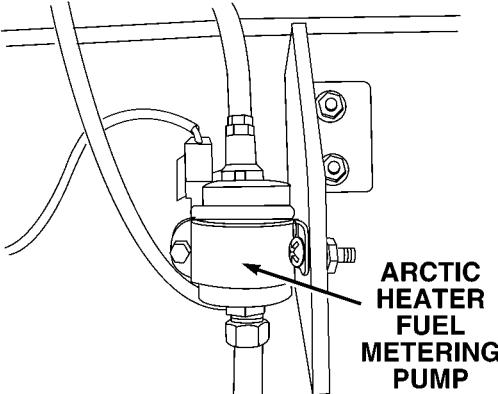
Malfunction	Test or Inspection	Corrective Action
ARCTIC HEATER KIT (CONT)		
2. ARCTIC HEATER DIAGNOSTIC TROUBLESHOOTING (DIRECT LEVEL) (MODEL B) (CONT).		
		
Step 29.	Remove arctic heater control unit (para 21-3).	
Step 30.	Perform resistance check across arctic heater flame sensor at room temperature (-13° to 77°F [-25° to 25°C]). Connect probes across arctic heater internal harness connector terminals No. 15 and 16.	<p>If resistance reading is between 900 and 1100 ohms, replace arctic heater glow pin (para 21-3).</p> <p>If resistance reading is not between 900 and 1100 ohms, replace arctic heater flame sensor (para 21-3).</p>
Step 31.	Go to Step 36.	
NOTE		
<ul style="list-style-type: none"> • Audible clicking and no or low fuel flow may indicate the arctic heater fuel system is not primed. • Arctic heater may go into lockout (code 050), due to too many start attempts. If arctic heater goes into lockout, go to Step 34. 		
Step 32.	Attempt to prime arctic heater fuel system. Turn arctic heater switch on and observe system operation. If system shuts down after the second start attempt, turn arctic heater switch off and on to repeat start cycle. Repeat start cycle four times (eight start attempts) or until arctic heater starts.	<p>If arctic heater does not operate, go to Step 34.</p> <p>If arctic heater fuel metering pump fails to prime within ten start attempts, replace arctic heater fuel metering pump (TM 9-2320-279-20-3).</p>
Step 33.	Go to Step 36.	
Step 34.	If Fault Code Retrieval Device (FCRD) is available, clear fault code 050 and go to Step 32.	
Step 35.	If Fault Code Retrieval Device (FCRD) is not available, replace arctic heater control unit (para 21-3) and go to Step 32.	

Troubleshooting Malfunctions (Cont)

Table 2-3. Troubleshooting (Cont)

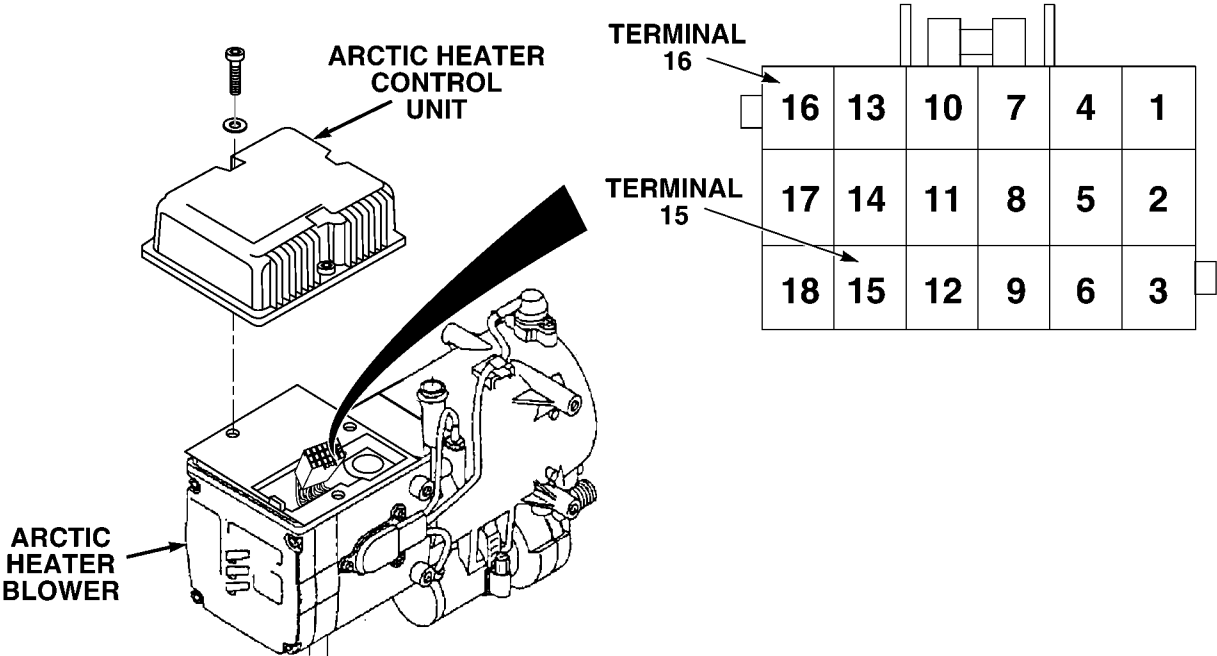
Malfunction	Test or Inspection	Corrective Action																		
ARCTIC HEATER KIT																				
2. ARCTIC HEATER DIAGNOSTIC TROUBLESHOOTING (DIRECT LEVEL) (MODEL B) (CONT).																				
Step 36.	Check if arctic heater operates.	If arctic heater operates, go to Step 50.																		
Step 37.	If Fault Code Retrieval Device (FCRD) is available, clear fault code 050 and go to Step 50.																			
Step 38.	If Fault Code Retrieval Device (FCRD) is not available, replace arctic heater control unit (para 21-3) and go to Step 50.																			
NOTE																				
Steps (39) through (41) are for fault codes 051, 064 or 065.																				
Step 39.	Remove arctic heater control unit (para 21-3).																			
Step 40.	Perform resistance check across arctic heater flame sensor at room temperature (-13° to 77°F [-25° to 25°C]). Connect probes across arctic heater internal harness connector terminals No. 15 and 16.	<p>If resistance reading is between 900 and 1100 ohms, replace arctic heater control unit (para 21-3).</p> <p>If resistance reading is not between 900 and 1100 ohms, replace arctic heater flame sensor (para 21-3).</p>																		
Step 41.	Go to Step 50.																			
 <p>The diagram illustrates the removal of the Arctic Heater Control Unit from the Arctic Heater Blower. The control unit is shown being lifted away from the blower assembly. To the right, a terminal block is shown with 18 terminals arranged in a 3x6 grid. Terminal 16 is located at the top left, and terminal 15 is located at the bottom left. The terminals are numbered 1 through 18 in a row-major order.</p> <table border="1" data-bbox="1000 1163 1435 1425"> <tr> <td>16</td> <td>13</td> <td>10</td> <td>7</td> <td>4</td> <td>1</td> </tr> <tr> <td>17</td> <td>14</td> <td>11</td> <td>8</td> <td>5</td> <td>2</td> </tr> <tr> <td>18</td> <td>15</td> <td>12</td> <td>9</td> <td>6</td> <td>3</td> </tr> </table>			16	13	10	7	4	1	17	14	11	8	5	2	18	15	12	9	6	3
16	13	10	7	4	1															
17	14	11	8	5	2															
18	15	12	9	6	3															

Troubleshooting Malfunctions (Cont)

2-7. TROUBLESHOOTING INSTRUCTIONS (CONT).

Table 2-3. Troubleshooting (Cont)

Malfunction	Test or Inspection	Corrective Action
-------------	--------------------	-------------------

ARCTIC HEATER KIT (CONT)

2. ARCTIC HEATER DIAGNOSTIC TROUBLESHOOTING (DIRECT LEVEL) (MODEL B) (CONT).

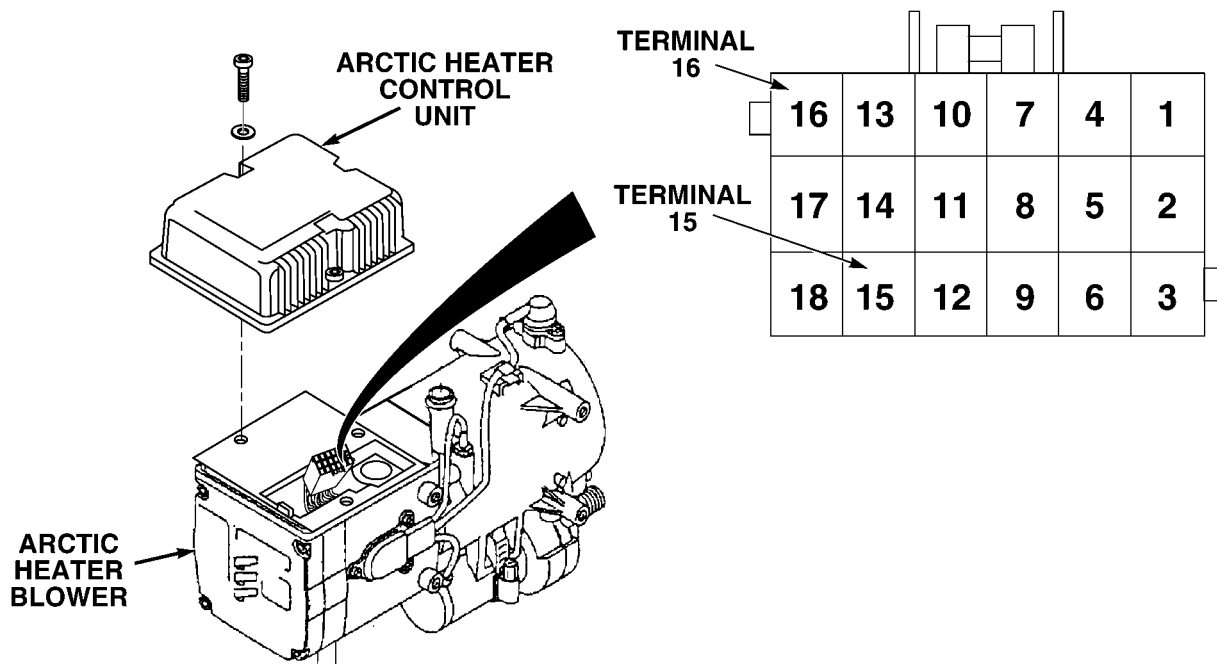

NOTE

Steps (42) through (44) are for fault codes 053, 054, 055 or 056.

Step 42. Remove arctic heater control unit (para 21-3).

Step 43. Perform resistance check across arctic heater flame sensor at room temperature (-13° to 77° F [-25° to 25° C]). Connect probes across arctic heater internal harness connector terminals No. 15 and 16.

If resistance reading is between 900 and 1100 ohms, replace arctic heater blower (para 21-3).

If resistance reading is not between 900 and 1100 ohms, replace arctic heater flame sensor (para 21-3).

Step 44. Go to Step 50.

Troubleshooting Malfunctions (Cont)

Table 2-3. Troubleshooting (Cont)

Malfunction Test or Inspection	Corrective Action
ARCTIC HEATER KIT	
2. ARCTIC HEATER DIAGNOSTIC TROUBLESHOOTING (DIRECT LEVEL) (MODEL B) (CONT).	
NOTE	
Steps (45) through (48) are for fault codes 060, 061, 071 or 072.	
Step 45. Remove arctic heater control unit (para 21-3).	
Step 46. Perform resistance check across arctic heater temperature sensor at room temperature (-13° to 77°F [-25° to 25°C]). Connect probes across arctic heater internal harness connector terminals No. 14 and 18.	
	If resistance reading is not between 650 and 1000 ohms, replace arctic heater temperature sensor (para 21-3) and go to Step 50.
Step 47. Perform resistance check across arctic overheat sensor at room temperature (-13° to 77°F [-25° to 25°C]). Connect probes across arctic heater internal harness connector terminals No. 11 and 17.	
	If resistance reading is between 10k and 150k ohms, replace arctic heater control unit (para 21-3).
	If resistance reading is not between 10k and 150k ohms, replace arctic heater overheat sensor (para 21-3).
Step 48. Go to Step 50.	

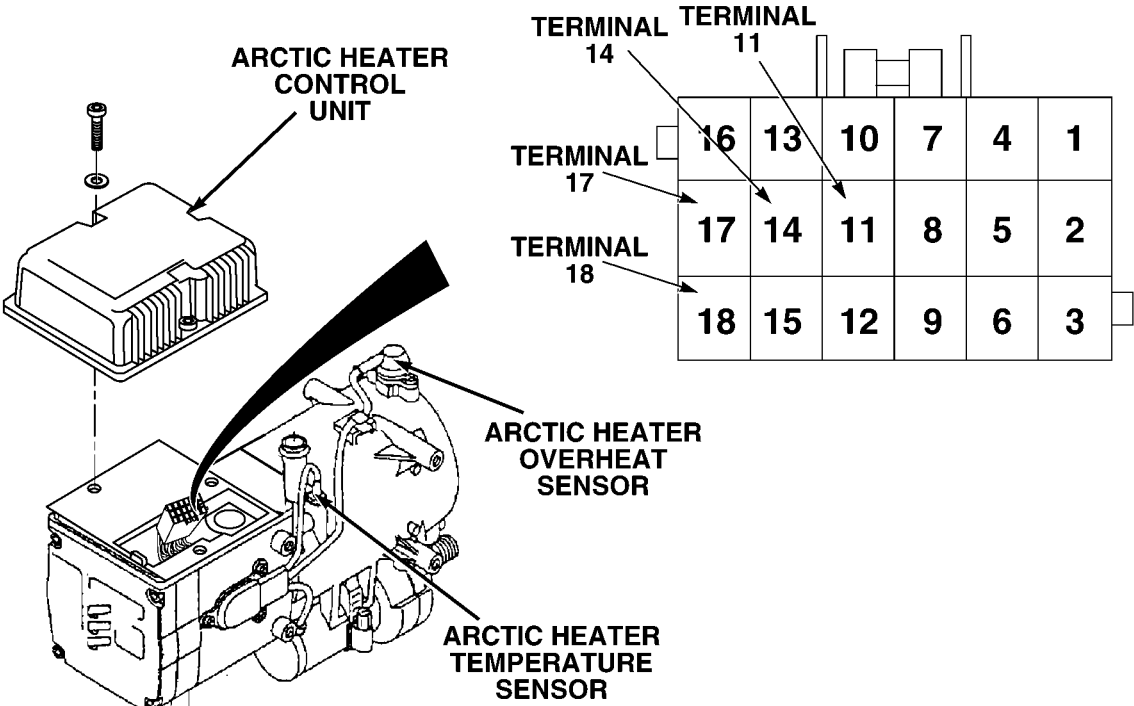

ARCTIC HEATER CONTROL UNIT

ARCTIC HEATER OVERHEAT SENSOR

ARCTIC HEATER TEMPERATURE SENSOR

TERMINAL 14	TERMINAL 11				
TERMINAL 17	TERMINAL 18	16	13	10	7
		17	14	11	8
		18	15	12	9
				6	3
				4	1
				5	2

Troubleshooting Malfunctions (Cont)

2-7. TROUBLESHOOTING INSTRUCTIONS (CONT).

Table 2-3. Troubleshooting (Cont)

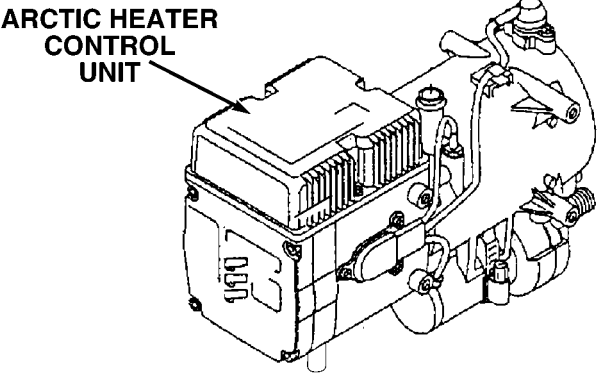
Malfunction	Test or Inspection	Corrective Action
ARCTIC HEATER KIT (CONT)		
2. ARCTIC HEATER DIAGNOSTIC TROUBLESHOOTING (DIRECT LEVEL) (MODEL B) (CONT).		
 <p>The diagram shows a rectangular control unit with a vented top and various mechanical components on the right side. An arrow points from the text 'ARCTIC HEATER CONTROL UNIT' to the top surface of the unit.</p>		
NOTE		
Step (49) is for fault codes 001, 002, 010, 011, 043, 047, 048, 090, 093, 094 or 097.		
Step 49. Replace arctic heater control unit (para 21-3).		
Step 50. If same fault code is displayed, notify the supervisor.		
Step 51. If different fault code is displayed, go to organizational arctic heater diagnostic troubleshooting (TM 9-2320-279-20-1).		

Section IV. MAINTENANCE PROCEDURES

2-8. GENERAL MAINTENANCE INSTRUCTIONS. General maintenance instructions for systems and components of the vehicle, except engine and transmission, and cranes on M984 and M985E1, are covered in this section. Refer to TM 9-2815-224-34&P for engine general maintenance procedures. Refer to Chapter 7 for transmission general maintenance procedures. Read all CAUTIONS and WARNINGS that apply to all maintenance procedures. Refer to TM 9-2320-279-20 for additional general maintenance procedures that may also apply. Refer to TM 9-2320-354-24&P or TM 9-2320-355-24&P for maintenance instructions that apply to cranes on M984 and M985E1 vehicles.

- a. Follow these maintenance practices when working on vehicle.

CAUTION

Do not use paint scrapers, knives, or other metal tools on aluminum parts and machined surfaces. Aluminum is easily gouged and machined surfaces easily scratched by steel tools.

- (1) Handle all parts and subassemblies carefully to prevent nicking, scratching, and denting.
- (2) Handle parts carefully to protect from damage and contamination during removal, cleaning and inspection, installation, and while stored in containers before installation.
- (3) When unpacking new parts, remove all packing material, barrier paper, tape, plastic bags, protective caps, and protective grease coating.
- (4) Do not unwrap parts until ready for use to protect from contamination and damage.

CAUTION

Do not use tape to close off fuel or oil openings. Sticky surface of tape can mix with fuel and oil and cause equipment malfunctions.

- (5) As soon as parts are removed, cap or cover open tubes, hoses, fittings, and openings in equipment to keep dust, dirt, and other objects out of internal parts. Use suitable containers to catch coolant, oil, or fuel spills.

WARNING

Be careful when working on or with electrical equipment. Voltage as low as 50 volts can cause injury or death. Always disconnect batteries when working on electrical equipment. For artificial respiration, refer to FM 21-11.

- (6) When repairing wire harness, remove wrap tape from wire harness, exposing wires for inspection. Lay new wires alongside wire harness and cut new wires 1-1/2 in. (38 mm) longer than wires being replaced. Cutting wires longer will allow organizational maintenance to replace damaged pins and sockets later without replacing wires.
- (7) When removing parts, inspect for breaks, dents, cracks, surface defects, and other visible **damage**.
- (8) When fastener tightening requirements are not given in maintenance task, tighten screws and nuts in accordance with Appendix D, TORQUE LIMITS.
- (9) The M977 series vehicles have a self bleeding hydraulic system. When the following steps are completed, air from the hydraulic system should be purged to the hydraulic reservoir.
 - (a) Operate crane (TM 9-2320-279-10) and hold each crane or winch control lever (except for hoist motor lever) completely in and then completely out for 30 seconds. Do this five times for each lever.
 - (b) Operate hoist motor control lever and run hoist cable out 10 ft (3 m) and then back on the winding drum. Do this three times.
- (10) Replace all gaskets, packings, and seals.
- (11) Replace lockwire, lockwashers, cotter pins, and plastic cable ties.
- (12) Lubricate packings with oil, Stretch packings and place in position, pressing packings evenly in place.

Maintenance Procedures (Cont)

2-8. GENERAL MAINTENANCE INSTRUCTIONS (CONT).

- (13) Replace broken, frayed, kinked, or soft flexible hydraulic hoses. If fittings are damaged, replace entire hose. Fittings not damaged or corroded can be used on new hoses.
- (14) Replace broken, frayed, or kinked air lines. If fittings on nylon lines are damaged, replace fittings. If fittings on flexible hoses are damaged, replace entire hose. Fittings not damaged or corroded can be used on new hoses and lines.
- (15) To prevent leaks, use pipe thread sealing compound or antiseize tape on threads of air line and hydraulic hose fittings.
- (16) Burring. Remove burrs from gear teeth with fine-cut tile and emery cloth. Remove burrs from sealing and bearing surfaces with crocus cloth.
- (17) Damaged Threads. Replace screws and nuts if threads are damaged. If threads on fittings are only slightly damaged, chase threads with chasing tool. Replace cross-threaded fittings. Inspect tapped holes for thread damage. If threads are damaged, tap hole for next oversize screw or stud. If retapping weakens part of cost of part makes retapping impractical, replace part.
- (18) Bearings. Refer to TM 9-214, Inspection, Care, and Maintenance of Antifriction Bearings. Lubricate bearings before assembly with lubricant used in the related housing. When installing bearings on shafts, apply pressure to inner race. When installing bearings in housing, apply pressure to outer race.
- (19) Welding. Refer to TM 9-237, Welding Theory and Application. Welding can be used to repair cracks and breaks in steel parts, such as brackets, panels, and light framework. Because of time required and chance of later failure, weld only when replacement parts are not available.
- (20) Grounding. To ensure good ground connections, clean or grind metal surfaces at connections to remove paint, oxides, corrosion, oils, and/or grease. After connections are completed, apply corrosion preventive compound to connections.

- b. Follow these general cleaning instructions and warnings,

WARNING

- Adhesives, solvents, and sealing compounds can burn easily, can give off harmful vapors, and are harmful to skin and clothing. To avoid injury or death, keep away from open fire and use in well-ventilated area. If adhesive, solvent, or sealing compound gets on skin or clothing, wash immediately with soap and water.
 - Trichlorethylene is toxic to skin, eyes, and respiratory tract. Avoid all exposure. Skin and eye protection, and exhaust hood on degreasing equipment are required. Contact unit safety officer for local procedures concerning the use of trichlorethylene before using.
 - Compressed air used for cleaning purposes will not exceed 30 psi (207 kPa). Use only with effective chip guarding and personal protective equipment, goggles, shield, and gloves.
- (1) Electrical parts such as coils, junction blocks, and switches must not be soaked or sprayed with cleaning solvents. Clean only with cloth moistened in drycleaning solvent (Item 57, Appendix C).
 - (2) Soak nonelectrical parts in drycleaning solvent and brush off caked deposits with paintbrush.
 - (3) Clean rubber parts with hot, soapy water and cloths. Do not clean with solvents.
 - (4) A degreasing machine may be used to remove heavy grease and oil deposits from metal parts. Trichlorethylene, MIL-T-27602B (Item 66, Appendix C) is used as degreasing agent.

Maintenance Procedures (Cont)

CAUTION

To prevent corrosion, parts should be coated with rust preventive within 2 hours of degreasing.

- (5) Remove parts from degreaser. Check that all oil passages and cavities are clean and clear. Before coating with rust preventive (Item 53, Appendix C), run thin flexible wire through oil passages to make sure they are not clogged. Use drycleaning solvent and compressed air to clean dirty oil passages.

Maintenance Procedures (Cont)

CAUTION

Do not use paint scrapers, knives, or other metal tools on aluminum parts and machined surfaces. Aluminum is easily gouged and machined surfaces easily scratched by steel tools.

- (6) Use reasonable care in cleaning machined surfaces with scrapers and wire brushes. Do not use abrasive wheels or compounds on machined surfaces.
 - (7) *Bearings*. Refer to TM 9-214, Inspection, Care, and Maintenance of Antifriction Bearings. When cleaning ball or roller bearings, place in basket and soak in dry cleaning solvent. Use paintbrush to remove caked deposits. Never use compressed air to clean and dry caged bearings. Caged bearings must drip and air dry. Do not spin bearings before thoroughly clean. Coat cleaned bearings liberally with lubricating oil, then wrap in protective wrapper if not using right away.
- C. Follow these general inspection instructions.
- (1) Inspect hoses and lines for damage or frayed coverings. Check for breaks or worn spots caused by kinking or contact with other parts of vehicle. Inspect fittings for damage. If fittings are damaged, look for possible causes of damage.
 - (2) Inspect wiring harnesses for chafed or burned insulation. Look for causes of chafing or burns. Inspect terminal connectors for loose connections and broken parts.
 - (3) Inspect all surfaces in contact with gaskets, packings, or seals for nicks, burrs, or scratches which might damage new seals. Remove defects with crocus cloth.
 - (4) Inspect castings and weldments for cracks and breaks. If the following patterns appear, replace parts.
 - (a) Bursts or scattered, short, sharp lines (indicates high temperature).
 - (b) Flakes or separate, short, wavy lines, usually in one general direction (indicates improper cooling).
 - (c) Grinding cracks (fine, sharp lines, tightly packed). On some surfaces, cracks may be shallow and hard to see. Grinding cracks are usually caused by a glazed grinding wheel rubbing (instead of cutting) and overheating the part.
 - (5) Inspect bearings. Clean, then lubricate bearings. Check for roughness of rotation. If rough, replace bearing. Check for cuts, grooves, pitting, scratched, cracked or chipped races, and for loose rollers or balls in caged bearings. If defect is found, replace bearing. Check bearing housing or shaft for grooves, burrs, or abrasions that would indicate bearing had been turned in housing or on shaft. If damage cannot be repaired with crocus cloth, replace defective part.
 - (6) Inspect bushings for scoring, burrs, roundness, sharp edges, and discoloration (overheated oil). Replace out-of-round and overheated bushings. Remove scoring with crocus cloth, and remove burrs and sharp edges with scraper or knife. Replace deeply scored bushings.
 - (7) Inspect gears for pitting, wear, and scoring.
 - (a) Slight scoring or minor marring of surfaces showing slight tears and scratches in direction of sliding is not a reason to replace gears. Heavy scoring may be reason to replace gear if equipment is not performing satisfactorily.
 - (b) Initial pitting, which occurs when gears are first started in service, is not serious if pitting only reduces high spots so there is still enough contact area to carry load without hurting performance.
 - (c) Destructive pitting, which follows initial pitting, may be serious because gears can be rapidly destroyed if load carrying area of gears is severely pitted.
 - (d) Abrasive wear is not normally serious unless gears are gouged or have worn deep grooves. Abrasive wear is caused by contaminated oil or grease in gear housing.

2-9. LUBRICATION INSTRUCTIONS.

Refer to LO 9-2320-279-12 for lubricating procedures.

Maintenance Procedures (Cont)

2-10. PREPARATION FOR STORAGE AND SHIPMENT.

- a. Refer to TM 9-2320-279-20 to prepare vehicle for storage or shipment.
- b. Refer to TB 9-2300-281-35 for overseas shipment instructions.
- c. Refer to TB 9-2300-281-35 for Basic Issue Items (BII) packing instructions.

2-11. PRE-EMBARKATION INSPECTION.

Refer to TB 9-2300-281-35 for pre-embarkation requirements.

CHAPTER 3 ENGINE MAINTENANCE

Contents	Para	Page
General	3-1	3-1
General Maintenance Instructions	3-2	3-1
Engine Removal/Installation	3-3	3-2
Engine to Engine Stand Installation/Removal	3-4	3-28

Section I. INTRODUCTION

3-1. GENERAL. This chapter contains maintenance instructions for removal, installation, and set-up for repair of the engine at the direct support and general support maintenance level. The subassemblies and parts which must be removed before the engine and components can be removed will be referenced to other paragraphs of this manual, TM 9-2320-279-20, or TM 9-2815-224-34&P.

Section II. SERVICE AND INSPECTION

Engine Maintenance Instructions

3-2. GENERAL MAINTENANCE INSTRUCTIONS.

- a. Follow these maintenance instructions when removing and installing engine:
- (1) When unpacking items, remove packing material (for example: barrier paper, tape, plastic bags, and protective caps).
 - (2) Cap or tape over engine inlets and exhaust ducts to prevent foreign objects from getting inside the engine. Keep dust, dirt, and other objects out of internal parts of the engine.

CAUTION

Do not use tape to close off fuel or oil openings. Sticky surface of tape will mix with fuel or oil and will get in the engine lines.

- (3) Cap or tape over open tubes, hoses, fittings, and engine openings as soon as parts are taken off.
 - (4) Use suitable container to catch oil and coolant when removing hoses, fittings, and plugs.
 - (5) Handle and store removed engine components carefully.
 - (6) Inspect parts as removed for breaks, dents, cracks, surface defects, or other obvious damage. Turn in bad parts. Set aside good parts for later use.
 - (7) When possible, replace gaskets, packings, and seals removed during repair work. Replace lockwire, lockwashers, and cotter pins at time of reassembly.
 - (8) Replace broken, worn, or burned electrical wiring.
 - (9) Replace broken, frayed, crimped, or soft flexible hoses. Replace stripped or damaged fittings. Replace entire connected flexible hose if fittings are damaged.
 - (10) Tag and mark shims, connectors, wires, valves, fittings, and mating ends of lines before disconnecting or removing. Identify similar parts to ensure correct assembly.
 - (11) Use hoist, jacks, and other aids when lifting engine.
- b. Follow these inspection instructions when removing and installing engine:
- (1) Inspect mounting surfaces and surfaces in contact with gaskets, seals, or machined surfaces. Look for burrs or scratches which might damage parts or seals upon installation. Remove any defects found.

Engine Maintenance Instructions (Cont)

3-2. GENERAL MAINTENANCE INSTRUCTIONS (CONT).

- (2) Remove drainplugs from engine system components and inspect sediment sticking to plug. Grit or fine metal particles may indicate actual or potential component failure. A few fine particles are normal. This inspection will help to show defective parts before internal inspection of the component.
- (3) Inspect hose surfaces for broken or frayed fabric. Check for breaks caused by sharp kinks or contact with other parts of the vehicle. Inspect fitting threads for damage. Replace any defective part. After assembly and during initial vehicle operation period, check for leaks. Inspect wiring harnesses for chafed or burned insulation. Inspect terminal connectors for loose connections and broken parts. Visually inspect castings and weldments for cracks.

Section III. ENGINE ASSEMBLY

3-3. ENGINE REMOVAL/INSTALLATION.	
This task covers:	
a. Removal	c. Follow-on Maintenance
b. Installation	
INITIAL SETUP	
<i>Models</i>	<i>Equipment Condition</i>
All	<i>TM or Para</i> <i>Condition Description</i>
	TM 9-2320-279-10 Spare tire removed.
<i>Test Equipment</i>	TM 9-2320-279-10 Transmission and transfer case set to N.
None	TM 9-2320-279-10 Hoist end of tire davit removed.
<i>Special Tools</i>	TM 9-2320-279-10 Rear engine cover frame removed.
None	TM 9-2320-279-10 Batteries disconnected.
<i>Supplies</i>	TM 9-2320-279-10 Radiator removed.
Compound, sealing, pipe thread, Item 29, Appendix C	LO 9-2320-279-12 Hydraulic reservoir drained.
Tags, identification, Item 60, Appendix C	LO 9-2320-279-12 Engine oil drained.
Sealant, RTV200 Electrical, Item 55.2, Appendix C	Para 13-6 Slinging support assemblies removed.
Connector, electrical, butt, Item 31, Appendix C	
Oil, lubricating, Item 47, Appendix C	<i>Special Environmental Conditions</i>
	None
<i>Personnel Required</i>	<i>General Safety Instructions</i>
MOS 63W, Wheel vehicle repairer (3)	Wheels chocked.
<i>References</i>	<i>Level of Maintenance</i>
None	Direct Support

Engine Maintenance Instructions (Cont)

a. Removal.

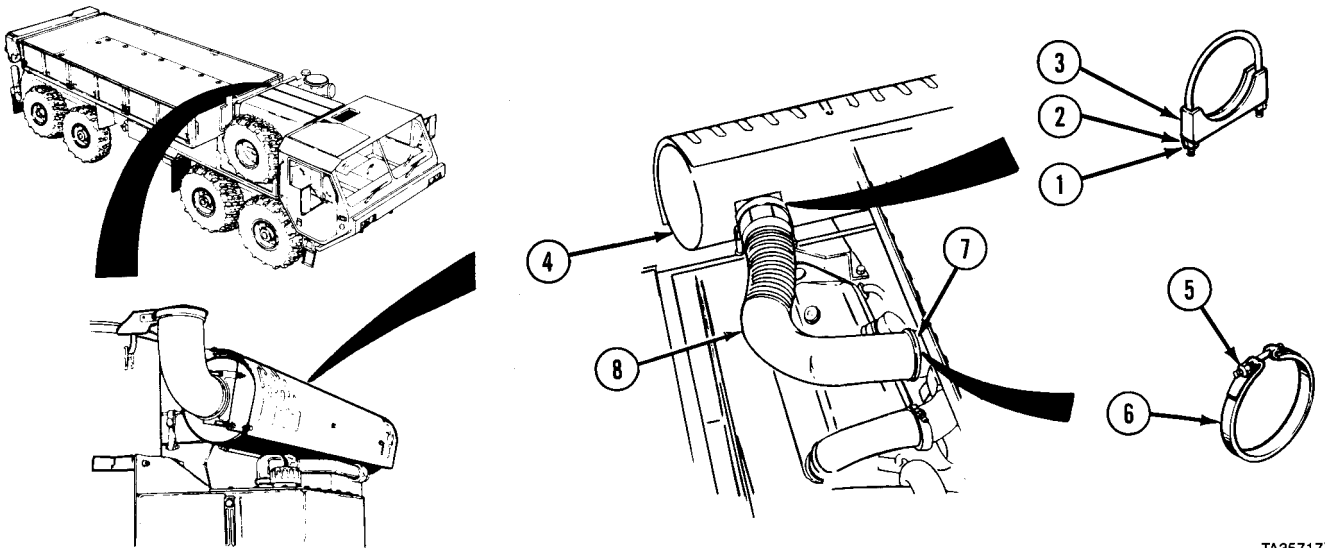

TA357177

- (1) Remove two nuts (1) and washers (2). Remove clamp (3) from muffer (4).
- (2) Remove nut (5) and clamp (6) from turbocharger (7).
- (3) Pull exhaust pipe (8) from turbocharger (7).
- (4) Remove exhaust pipe (8) from muffer (4).

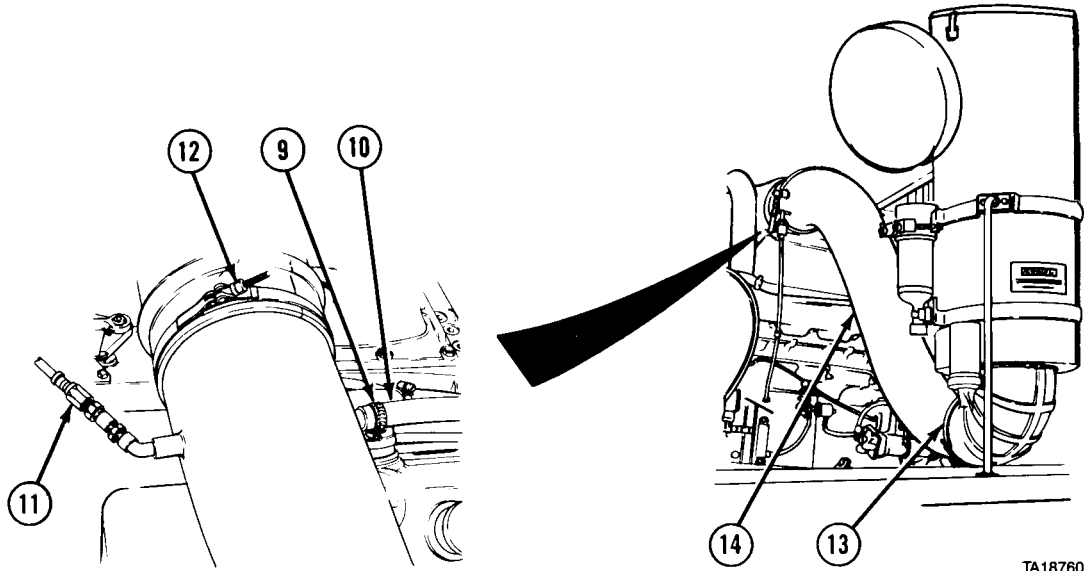

TA187608

NOTE

Tag and mark hoses before removal.

- (5) Loosen clamp (9) and remove hose (10).
- (6) Remove hose (11).
- (7) Loosen clamps (12 and 13) and remove air intake duct (14).

Engine Maintenance Instructions (Cont)

3-3. ENGINE REMOVAL/INSTALLATION (CONT).

- (8) Remove four nuts (15) and screws (16).
- (9) Soldier A and Soldier B remove muffler assembly (17).

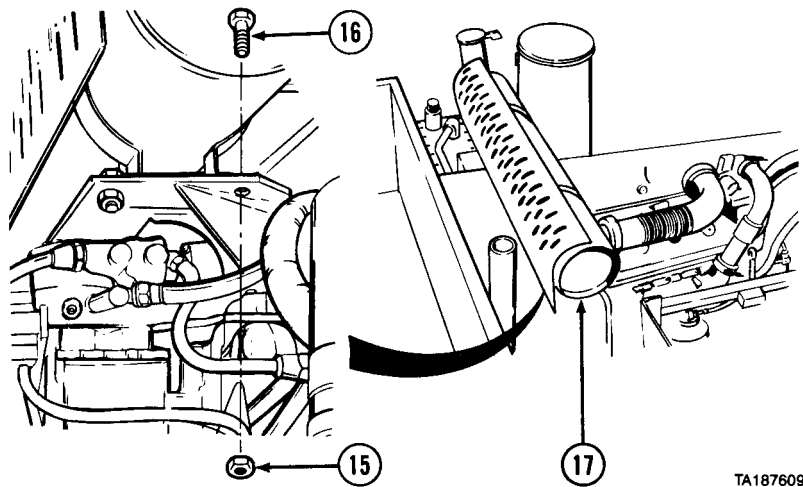

TA187609

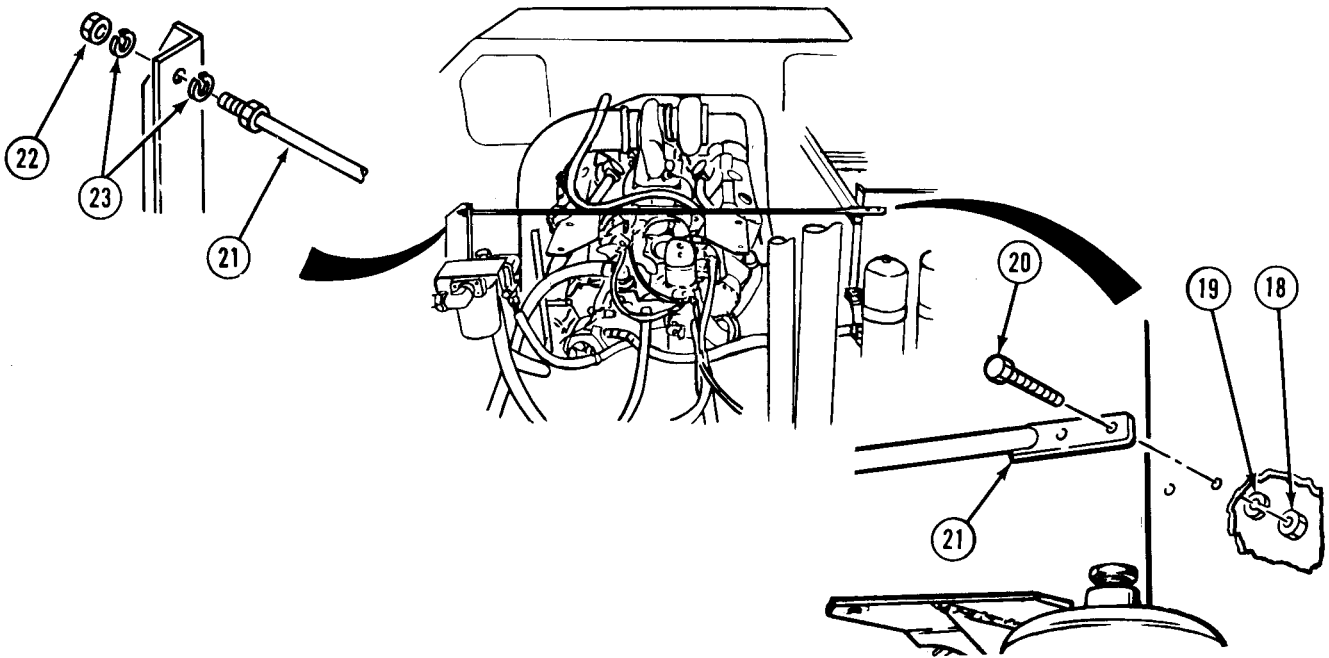

TA187610

- (10) Remove two nuts (18), lockwashers (19), and screws (20) from cross brace (21).
- (11) Remove nut (22) and two lockwashers (23) from other end of cross brace (21).
- (12) Remove cross brace (21).

Engine Maintenance Instructions (Cont)

NOTE

Attach chain with lifting hooks facing out and with front leg under exhaust pipe.

- (13) Soldier A attaches 39-in. (1 m) chain to two side lifting brackets (24) and 37-in. (94 cm) chain to forward lifting bracket (25) while Soldier B operates lifting device.

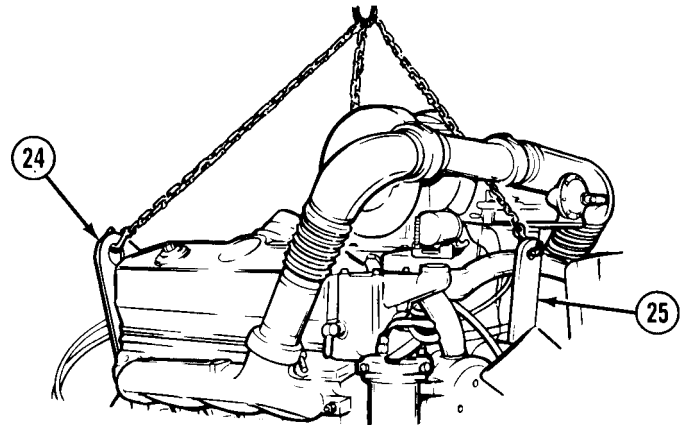

TA187611

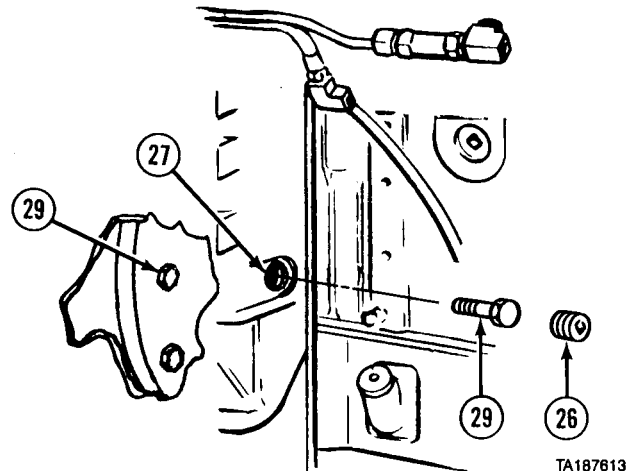
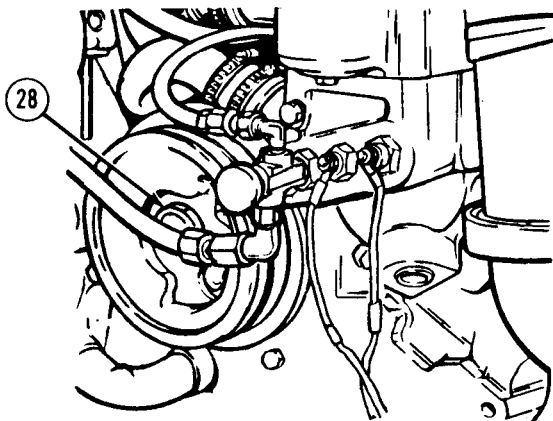

TA187613

- (14) Remove plug (26) from access hole (27).

NOTE

There are 12 torque converter screws. Each must be centered in access hole for removal.

- (15) Soldier A looks in access hole (27) while Soldier B turns pulley nut (28) slowly clockwise.
- (16) Soldier A tells Soldier B to stop turning pulley nut (28) when torque converter screw (29) is centered in access hole (27).
- (17) Remove torque converter screw (29).

NOTE

Repeat steps (15), (16), and (17) until all 12 torque converter screws are removed.

3-3. ENGINE REMOVAL/INSTALLATION (CONT).

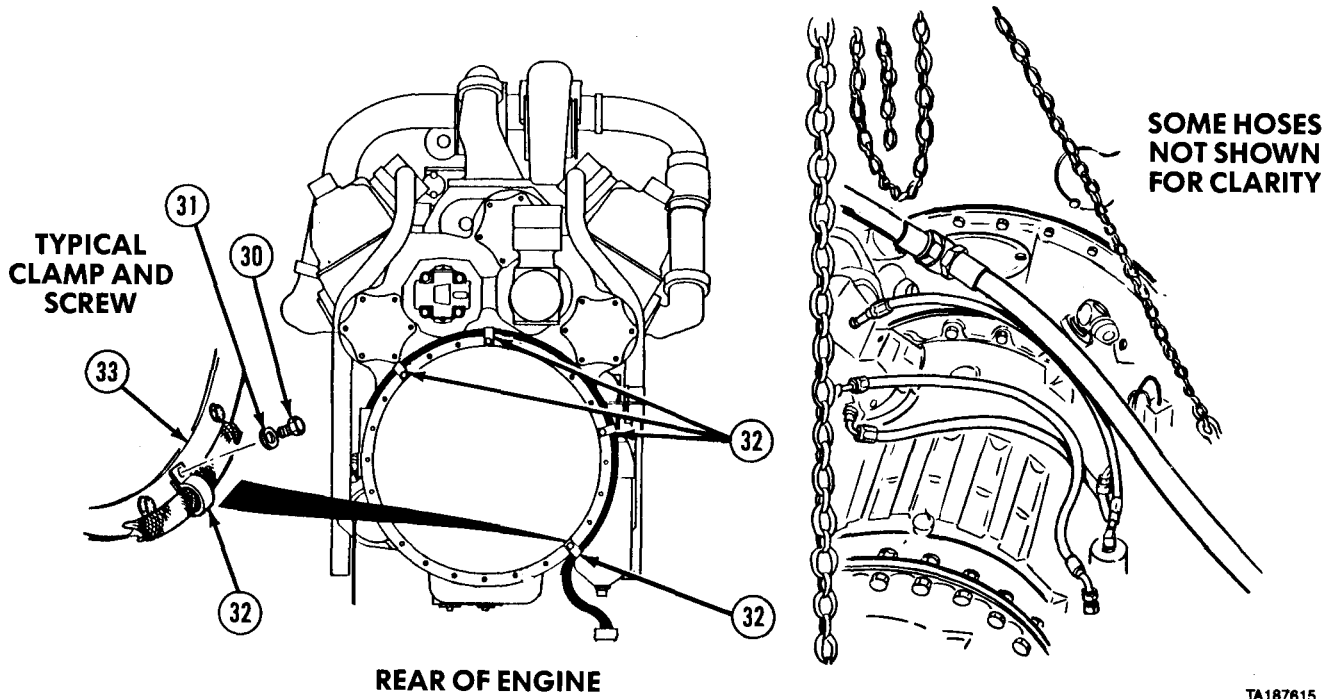

(18) Remove 13 screws (30), lockwashers (31), and three clamps (32) from top of transmission torque converter housing (33). Remove 11 screws, lockwashers, and one clamp from bottom of housing.

(19) Loosen clamps (34, 35, and 36) and remove three hoses (37, 38, and 39).

(20) Disconnect two fuel hoses (40 and 41).

(21) Disconnect airhose (42).

Engine Maintenance Instructions (Cont)

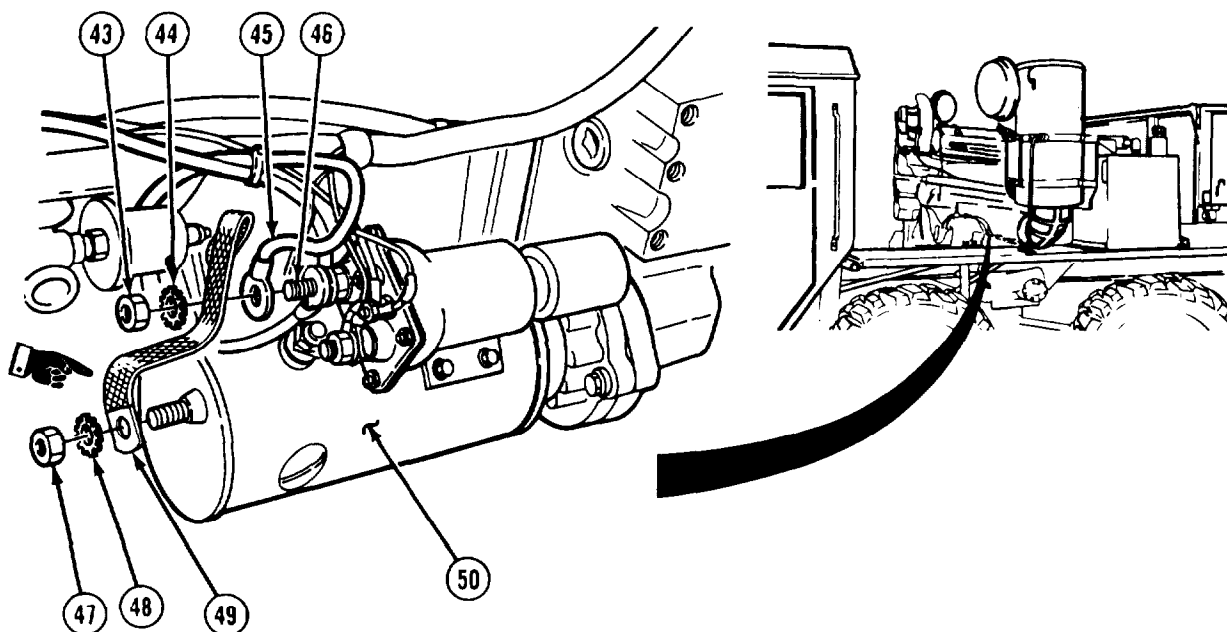

- (22) Remove nut (43) and lockwasher (44).

NOTE

Tag and mark wires before disconnecting.

- (23) Disconnect five wires (45) from solenoid (46).
- (24) Remove nut (47) and lockwasher (48).
- (25) Disconnect seven starter wires (49) from starter (50).

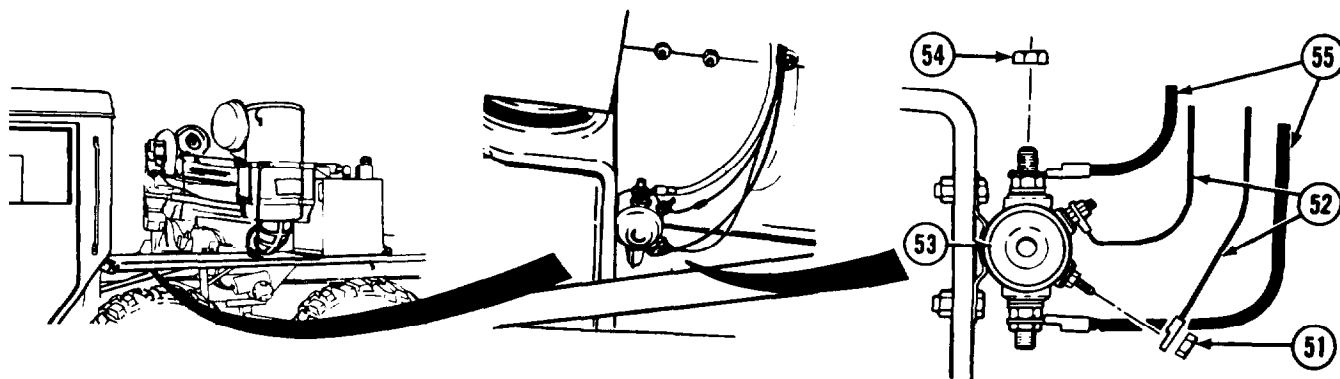

- (26) Remove two nuts (51) and wires (52) from relay (53).
- (27) Remove two nuts (54) and cables (55).

Engine Maintenance Instructions (Cont)

3-3. ENGINE REMOVAL/INSTALLATION (CONT).

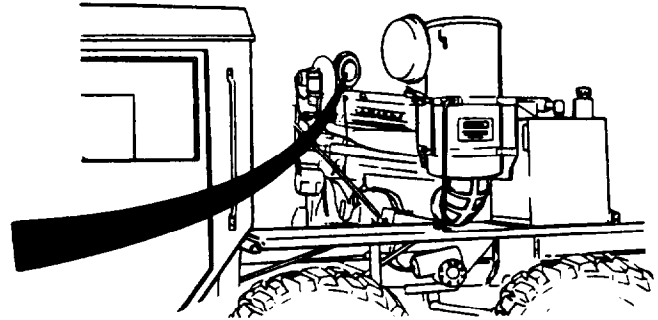
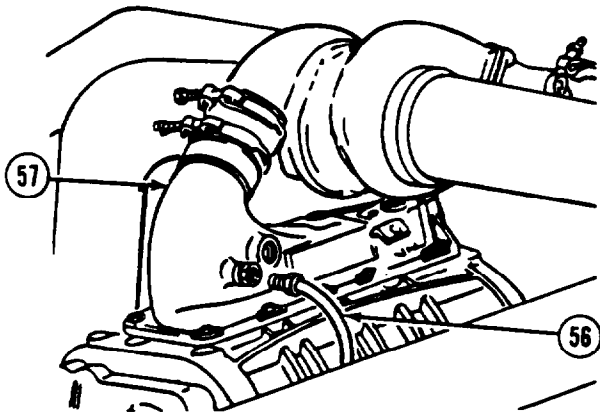

TA187619

(28) Remove ether starting aid tube (56) from air inlet housing (57).

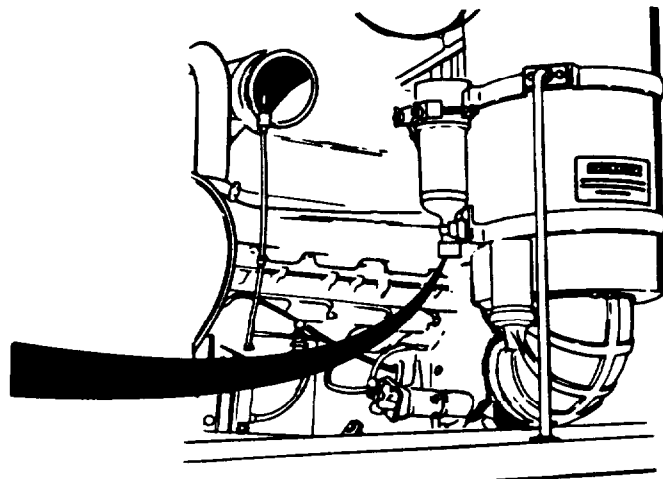
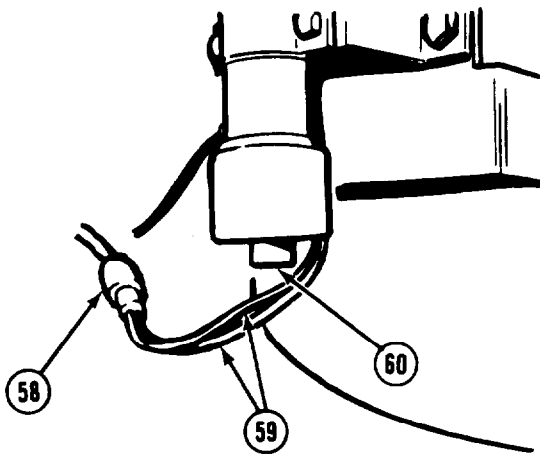

TA187620

(29) Disconnect plug (58) from wires (59) at ether starting aid (60).

Engine Maintenance Instructions (Cont)

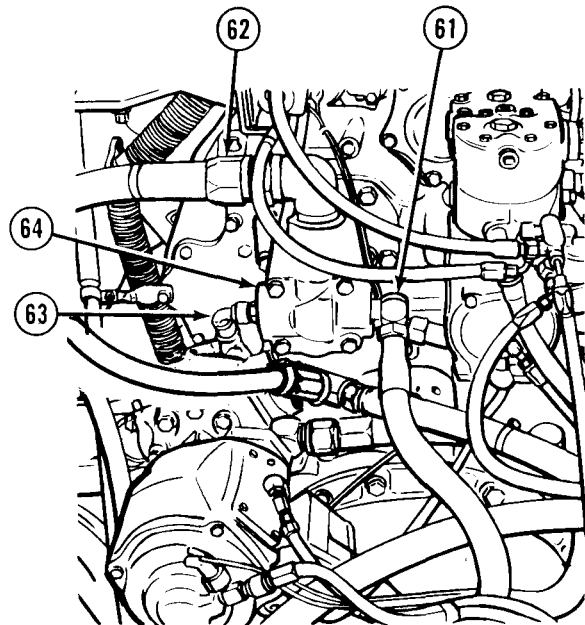
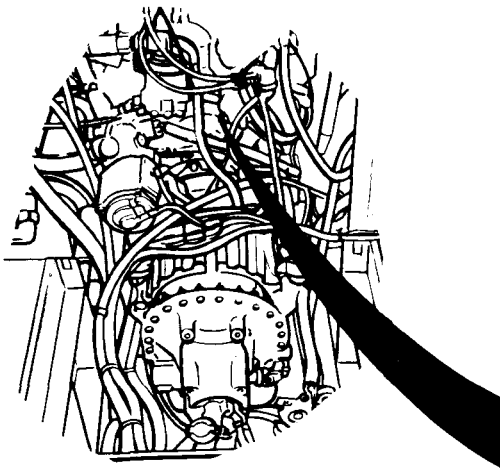

TA187621

(30) Disconnect three hoses (61, 62, and 63) from steering pump (64).

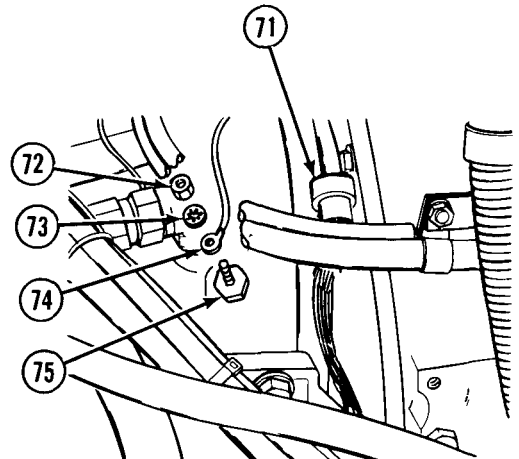
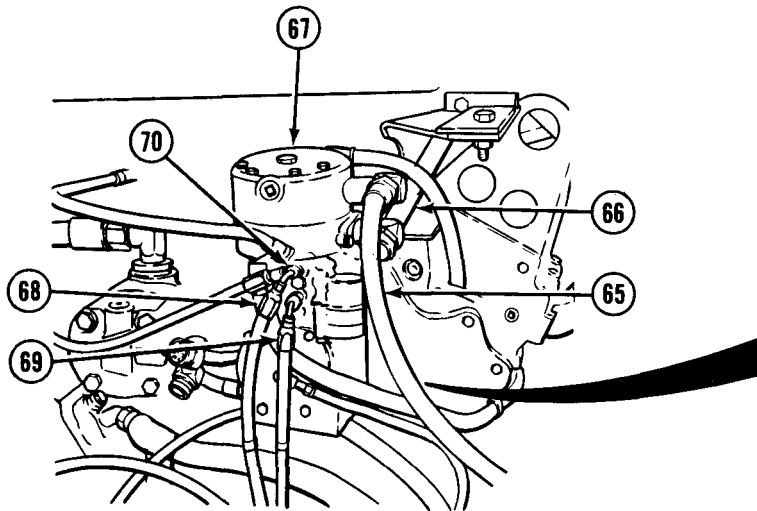

TA187622

- (31) Disconnect two hoses (65 and 66) from air compressor (67).
- (32) Disconnect two hoses (68 and 69) from governor (70).
- (33) Disconnect STE/ICE connector (71).
- (34) Remove nut (72) and lockwasher (73).
- (35) Disconnect wire (74) from temperature sending unit (75).

Engine Maintenance Instructions (Cont)

3-3. ENGINE REMOVAL/INSTALLATION (CONT).

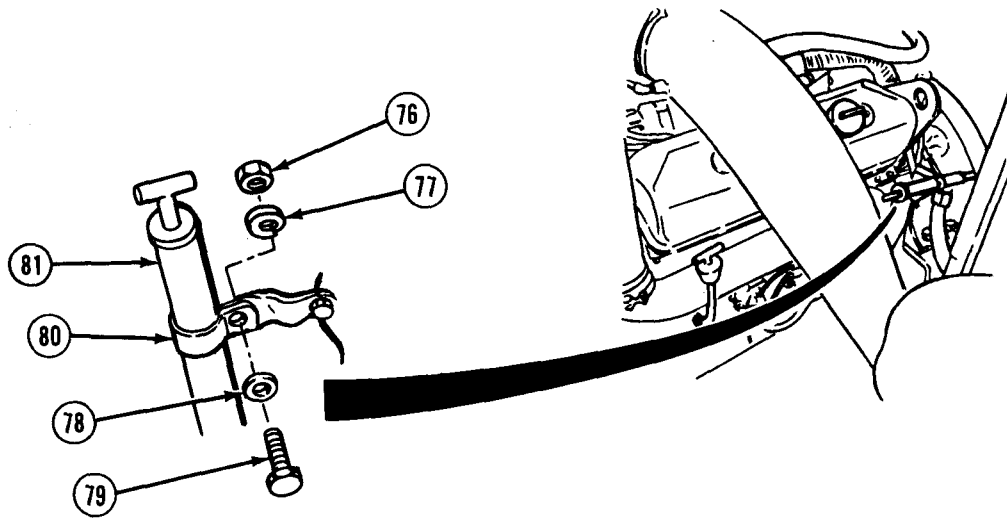

TA187623

- (36) Remove nut (76), lockwasher (77), washer (78), and screw (79).
- (37) Move clamp (80) and transmission dipstick tube (81) aside.

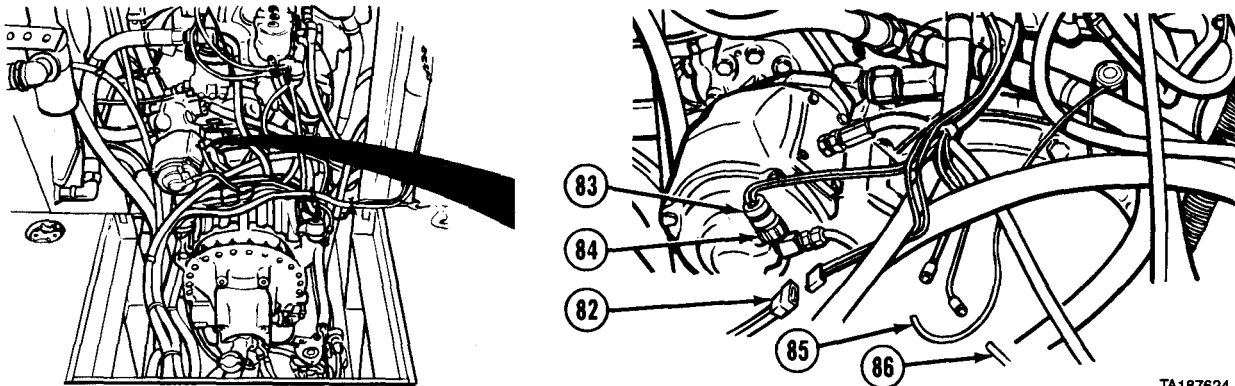

TA187624

- (38) Disconnect plug (82).
- (39) Disconnect plug (83) from PTO pressure switch (84).
- (40) Cut two wires (85 and 86) at electrical butt connectors.

Engine Maintenance Instructions (Cont)

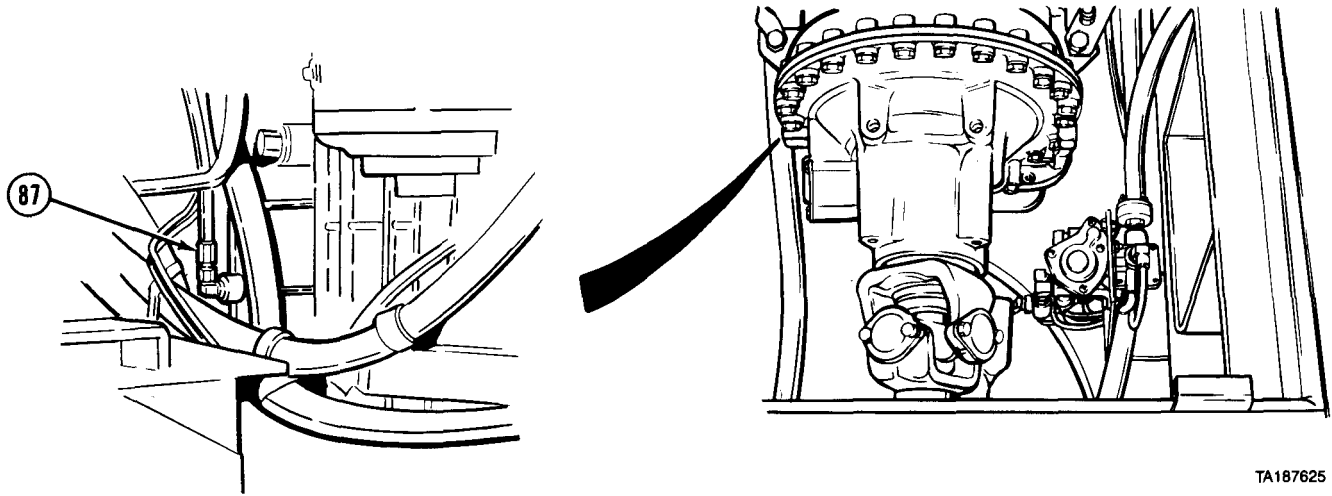

TA187625

(41) Disconnect hose (87).

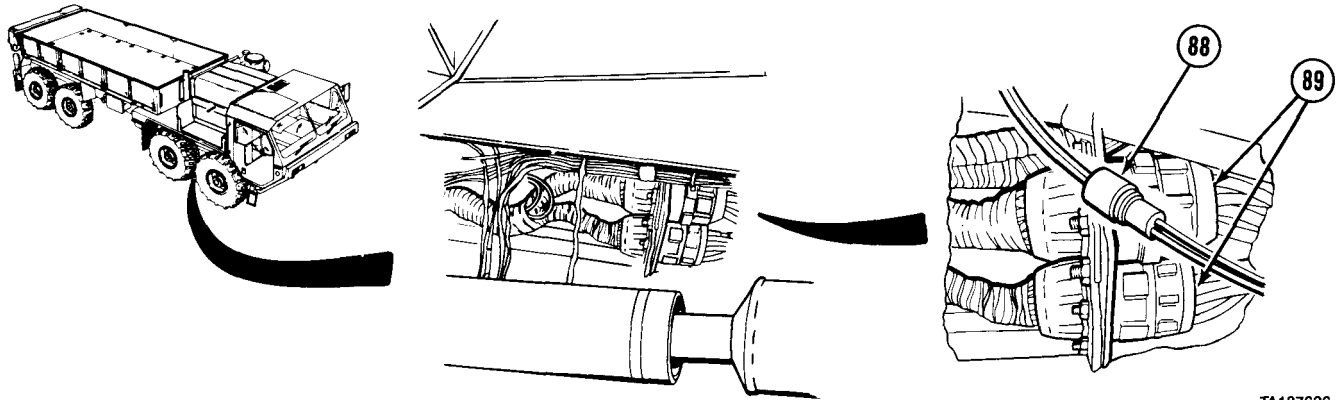

TA187626

(42) Disconnect connector (88).

(43) Disconnect two connectors (89).

Engine Maintenance Instructions (Cont)

3-3. ENGINE REMOVAL/INSTALLATION (CONT).

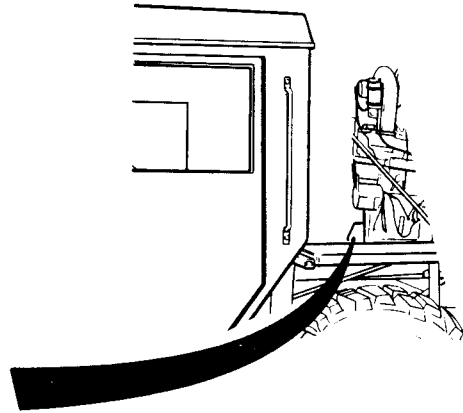
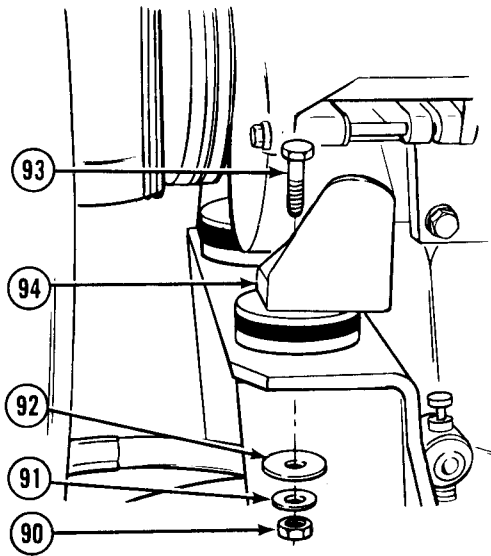

TA187627

(44) Remove nut (90), washer (91), spacer (92), and screw (93) from each of two engine supports (94).

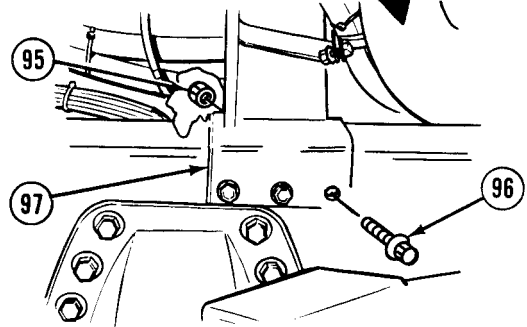
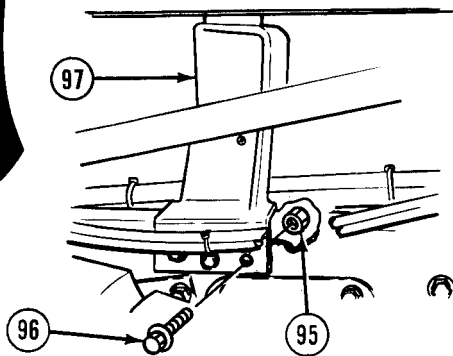
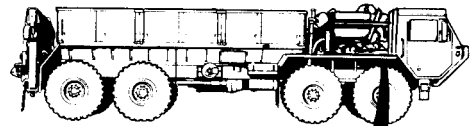
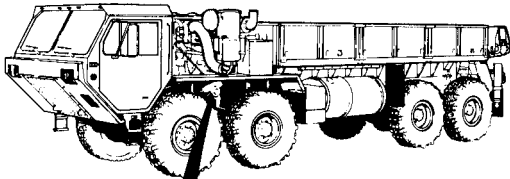

TA187628

(45) Soldier A and Soldier B remove three nuts (95) and screws (96) from each side of engine frame support (97).

Engine Maintenance Instructions (Cont)

WARNING

Keep out from under engine when removing from vehicle. If engine slips, sways, or falls, serious injury or death may result.

CAUTION

- Make sure loose hoses and wires are secure and moved out of way so they do not snag and cause damage when engine is lifted.
 - Before lifting engine completely out of vehicle, test by lifting slightly to see if balanced. If engine starts to tilt, lower and adjust chain lengths. Unbalanced engine may swing causing damage.
- (46) Soldier A and Soldier B slide engine frame support (97) forward on vehicle while Soldier C operates lifting device to lift engine (98) slightly.
 - (47) Soldier A and Soldier B guide engine (98) while Soldier C operates lifting device and removes engine from vehicle.
 - (48) Soldier A and Soldier B guide engine (98) to suitable work area while Soldier C operates lifting device.
 - (49) Disconnect lifting chains from engine (98).
 - (50) Remove four spacers (99) from biscuit mounts (100).

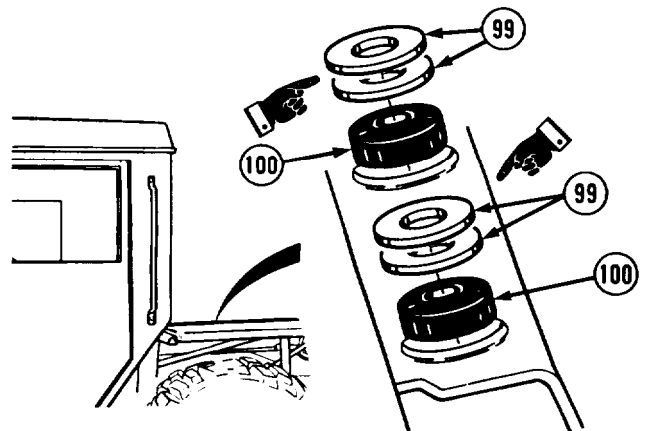
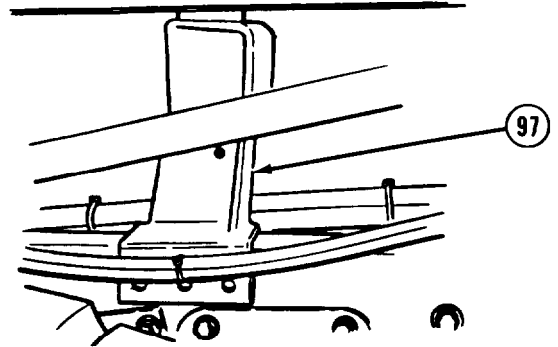
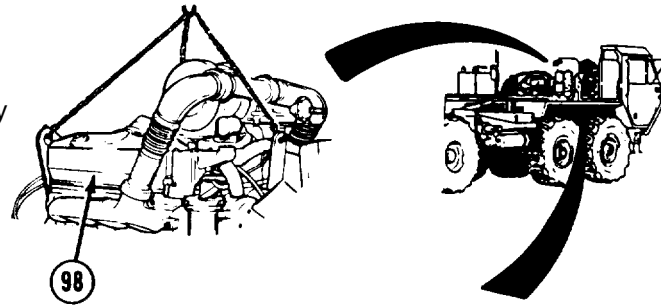

Engine Maintenance Instructions (Cont)

3-3. ENGINE REMOVAL/INSTALLATION (CONT).

b. Installation.

WARNING

- Adhesives, solvents, and sealing compounds can burn easily, can give off harmful vapors, and are harmful to skin and clothing. To avoid injury or death, keep away from open fire and use in well-ventilated area. If adhesive, solvent, or sealing compound gets on skin or clothing, wash immediately with soap and water.
- Keep out from under engine when lifting into vehicle. If engine slips, sways, or falls, serious injury or death may result.

CAUTION

- Install lifting hooks facing outward. Before lifting engine completely off supports, test by lifting slightly to see if balanced. If engine starts to tilt, lower and adjust chain lengths. Unbalanced engine can swing causing damage.
- Make sure hoses and wires are secured and moved out of the way when installing engine so they do not snag and cause damage.

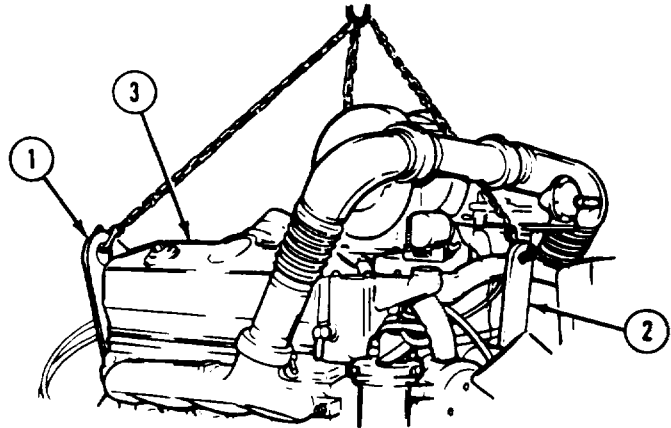

NOTE

- Apply electrical sealant to exposed wire connectors after installing connectors.
 - Attach chain with lifting hooks facing out and with front leg under exhaust pipe.
- (1) Install 39-in. (1 m) lifting chain on two side lifting brackets (1).
 - (2) Install 37-in. (94 cm) chain on forward lifting bracket (2).
 - (3) Soldier A operates lifting device and lifts engine (3) slightly, while Soldier B checks that engine is balanced.

CAUTION

Make sure engine is centered to prevent damage to bell-housing.

- (4) Soldier A operates lifting device and positions engine (3) in vehicle, while Soldier B and Soldier C guide engine.

Engine Maintenance Instructions (Cont)

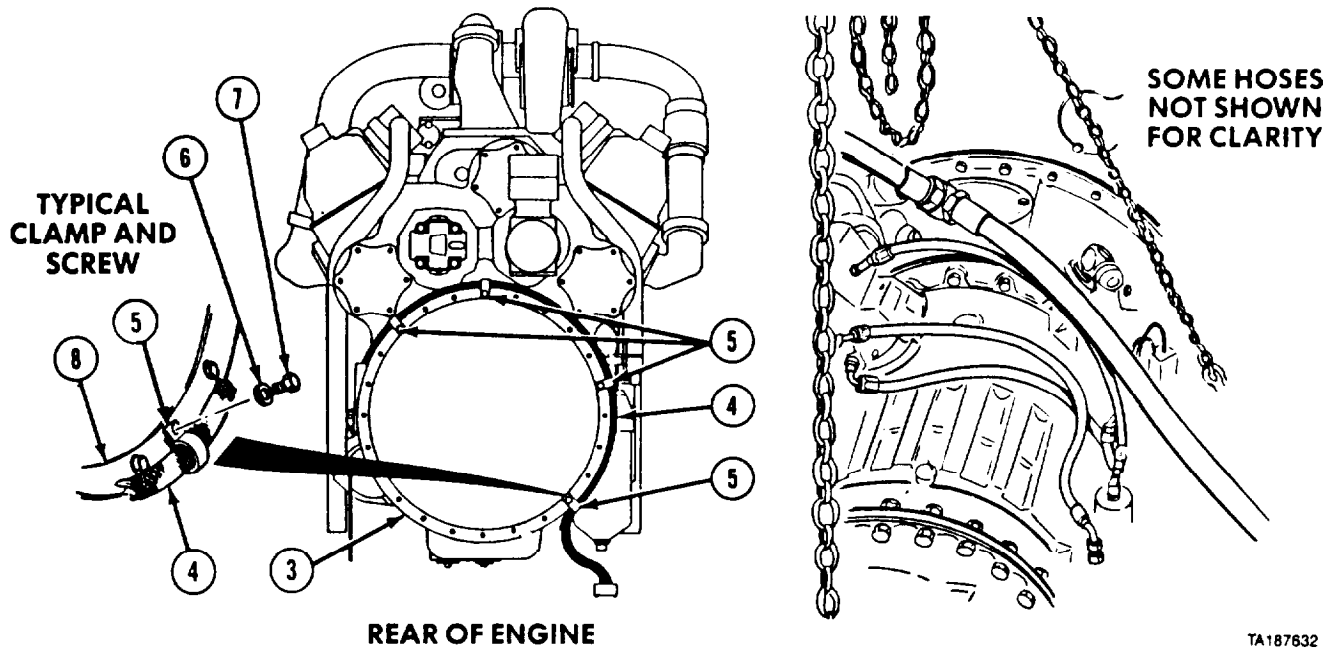

TA187832

- (5) Position wiring harness (4) around rear of engine (3).
- (6) Soldier A installs three clamps (5), 13 lockwashers (6), and screws (7) in top of transmission torque converter housing (8), while Soldier B installs one clamp, 11 lockwashers, and screws in bottom of housing.

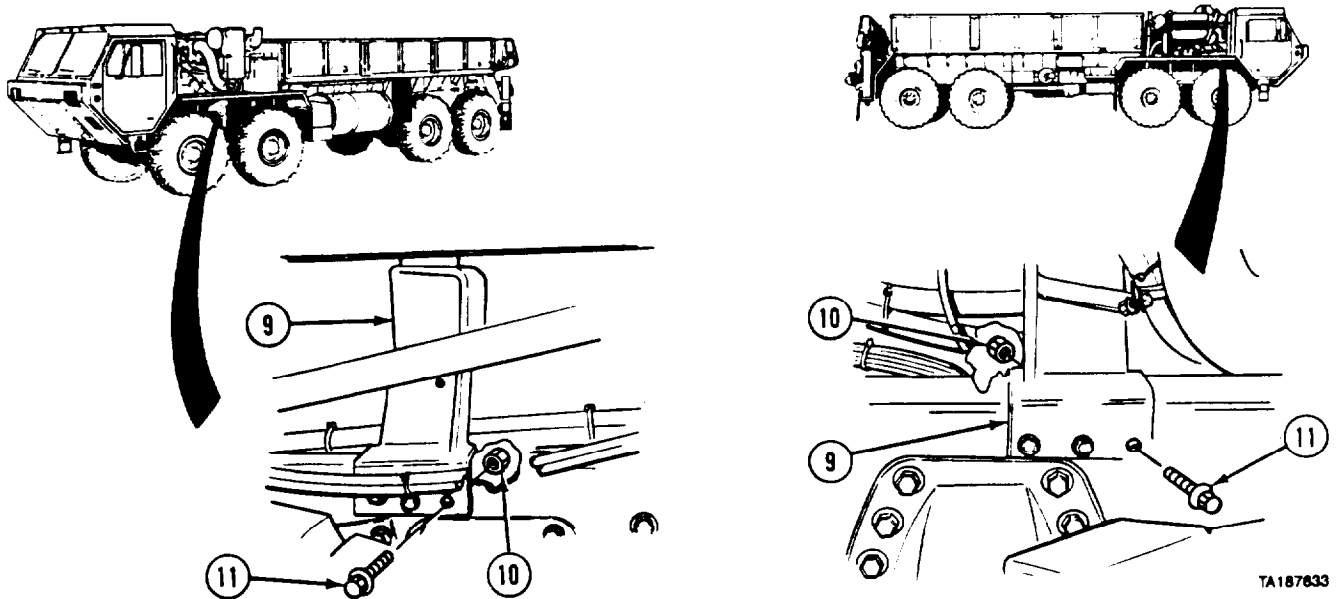

TA187833

- (7) Soldier A and Soldier B position engine frame support (9).
- (8) Soldier A installs and holds three nuts (10) on each side of engine frame support (9) while Soldier B installs three screws (11). Do not tighten nuts or screws.

Engine Maintenance Instructions (Cont)

3-3. ENGINE REMOVAL/INSTALLTION (CONT).

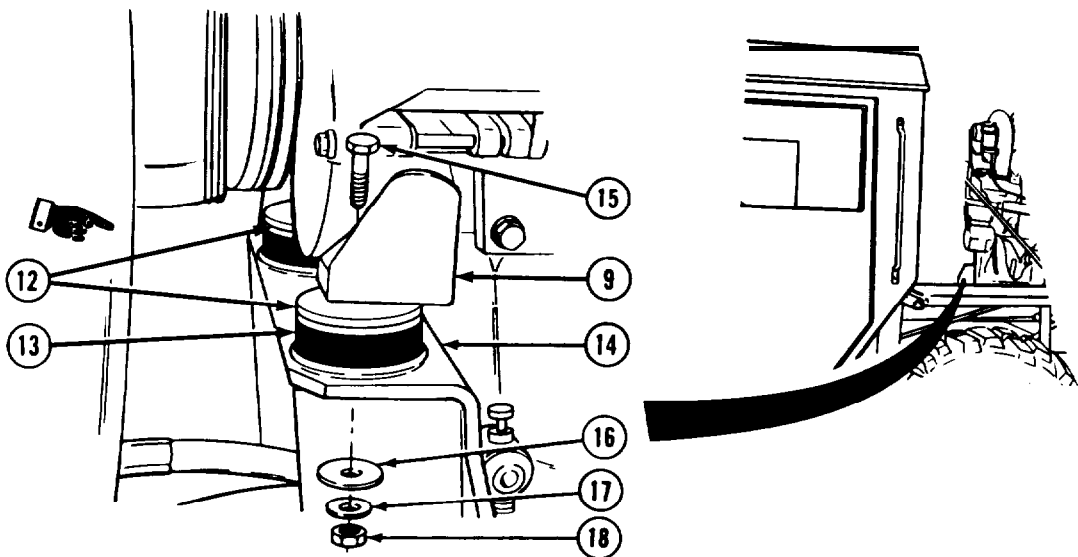

- (9) Install four spacers (12) on biscuit mounts (13).
- (10) Aline holes in engine frame support (9) with holes in biscuit mounts (13) on front engine support (14).
- (11) Soldier A lubricates and installs two screws (15), while Solider B installs two bottom spacers (16), two washers (17), and nuts (18).
- (12) Solider A holds two screws (15) while Soldier B tightens two nuts (18) to 170 lb-ft (230.5 Nom).

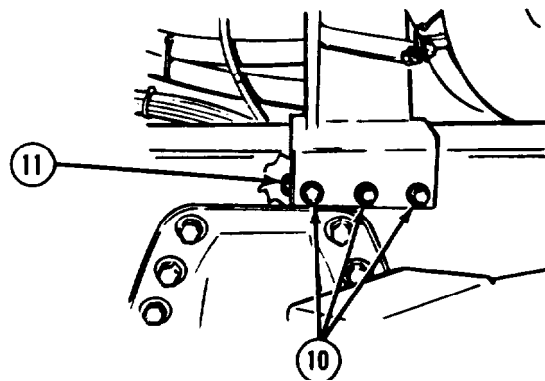
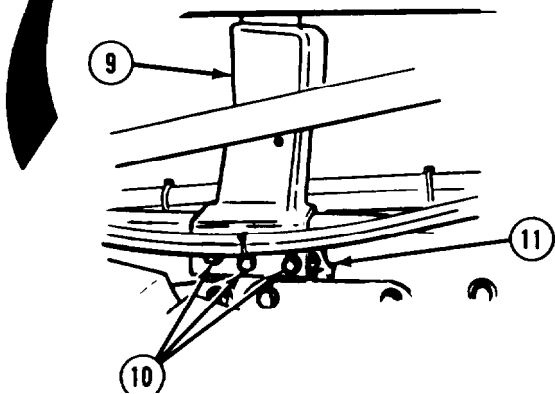
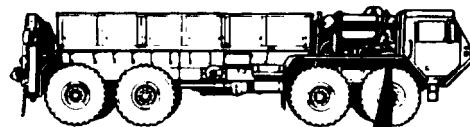
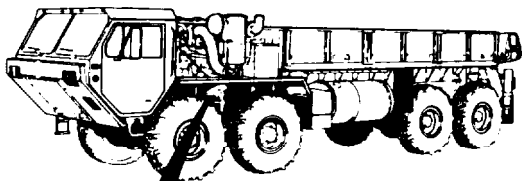

- (13) Soldier A tightens three screws (11) on each side of engine frame support (9) while Soldier B holds three nuts (10).

Engine Maintenance Instructions (Cont)

(14) Remove lifting chains from engine (3).

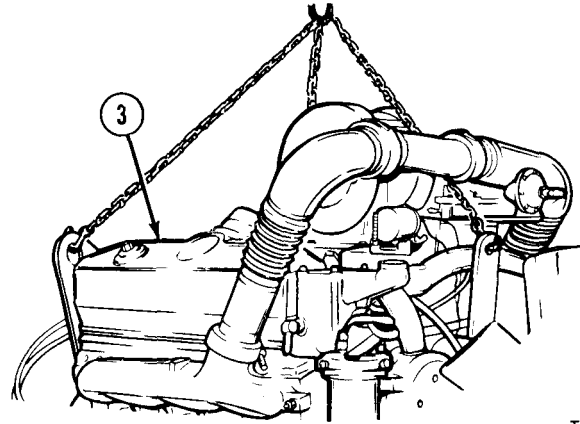

TA187636

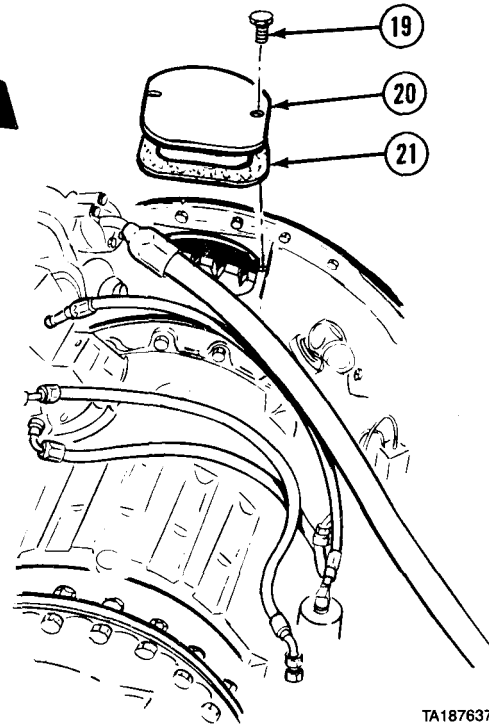
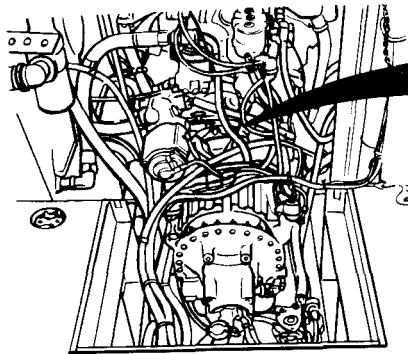

TA187637

(15) Remove two screws (19), inspection cover (20), and gasket (21).

3-3. ENGINE REMOVAL/INSTALLATION (CONT).

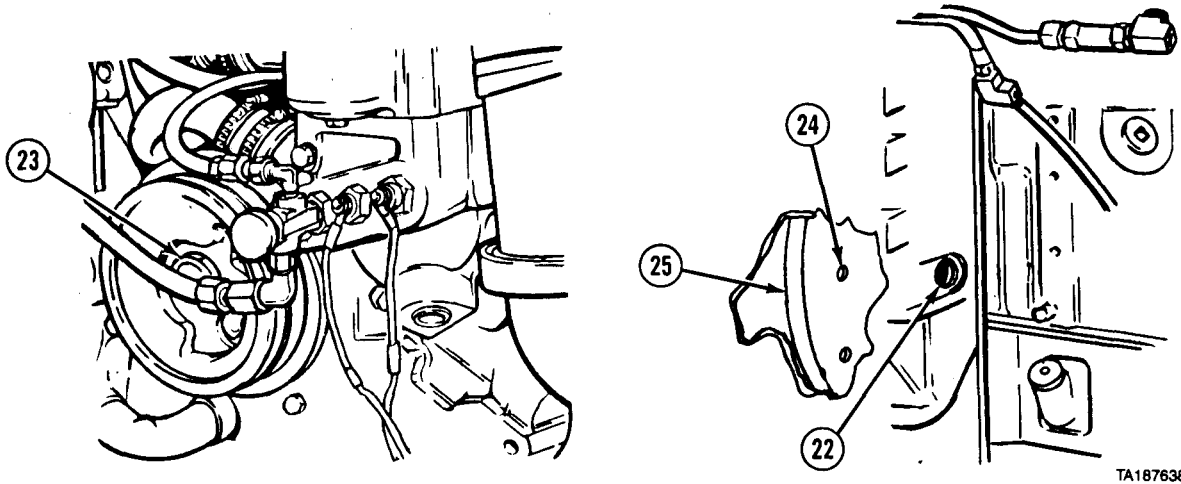

(16) Soldier A looks in access hole (22) while Soldier B turns pulley nut (23) clockwise. Soldier A tells Soldier B to stop turning pulley nut when screw hole (24) in torque converter (25) is centered in access hole.

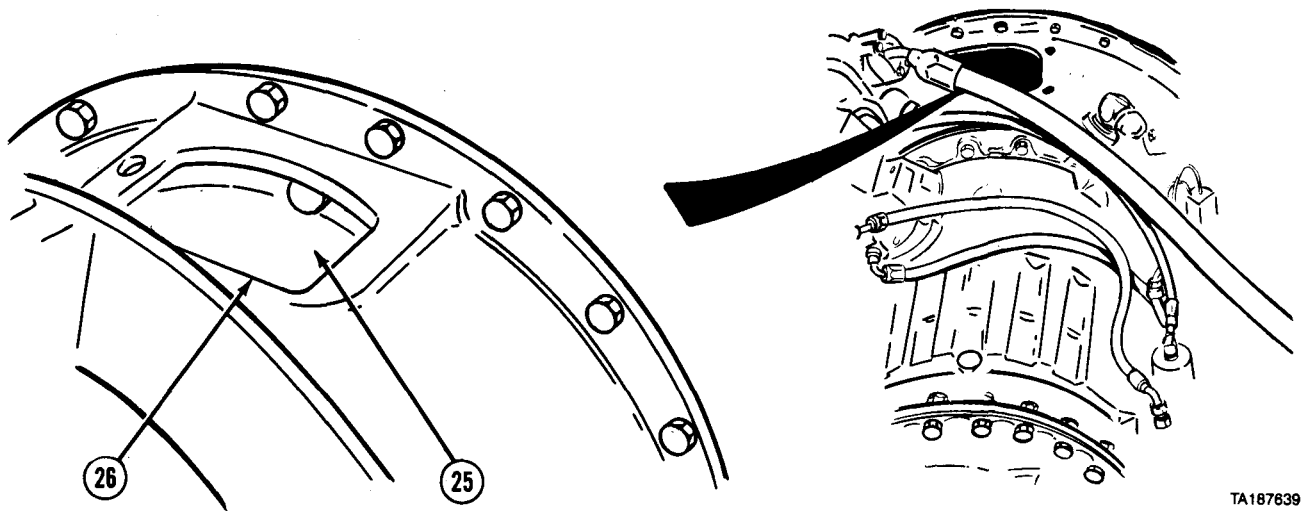

(17) Soldier A turns torque converter (25) through inspection opening (26) until told to stop by Soldier B.

Engine Maintenance Instructions (Cont)

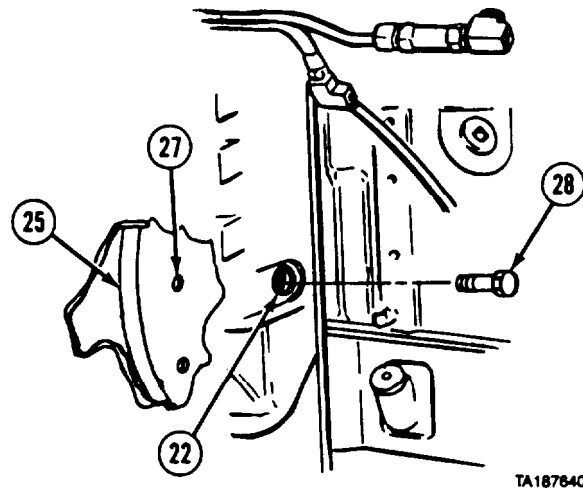

- (18) Soldier A looks in access hole (22) and tells Soldier B to stop turning torque converter (25) when screw hole (27) is centered in access hole.
- (19) Install, but do not fully tighten, one torque converter screw (28).

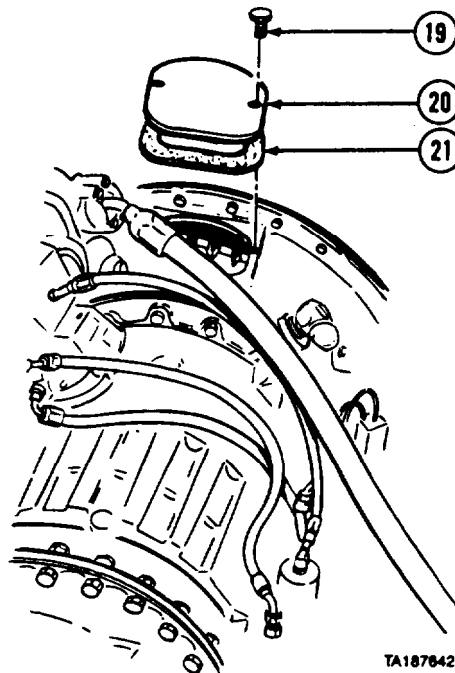

- (20) Install inspection cover (20) and gasket (21) with two screws (19).

Engine Maintenance Instructions (Cont)

3-3. ENGINE REMOVAL/INSTALLATION (CONT).

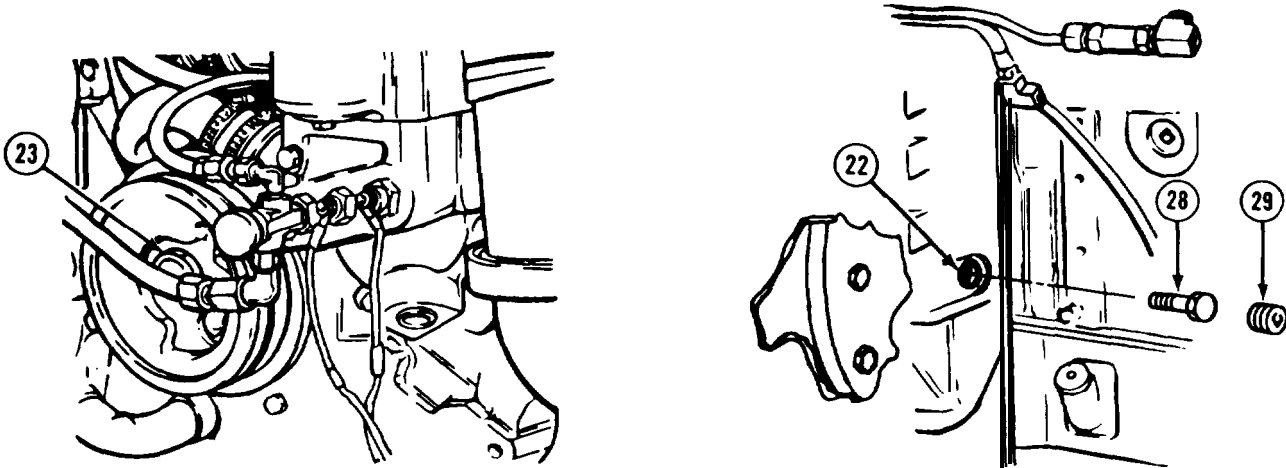

- (21) Soldier A looks in access hole (22) while Soldier B turns pulley nut (23) until screw hole is centered in access hole.
- (22) Install, but do not fully tighten, torque converter screw (28).

NOTE

Repeat steps (21) and (22) until all 12 torque converter screws have been installed.

- (23) Soldier A looks in access hole (22) while Soldier B turns pulley nut (23) clockwise.
- (24) Soldier A tells Soldier B to stop turning pulley nut (23) when torque converter screw (28) is centered in access hole (22).
- (25) Soldier A tightens torque converter screw (28) to 105 to 115 lb-ft (142 to 156 N•m).

NOTE

Repeat steps (23), (24), and (25) until all 12 torque converter screws have been tightened.

WARNING

Adhesives, solvents, and sealing compounds can burn easily, can give off harmful vapors, and are harmful to skin and clothing. To avoid injury or death, keep away from open fire and use in well-ventilated area. If adhesive, solvent, or sealing compound gets on skin or clothing, wash immediately with soap and water.

- (26) Apply pipe thread sealing compound and install plug (29) in access hole (22).

Engine Maintenance Instructions (Cont)

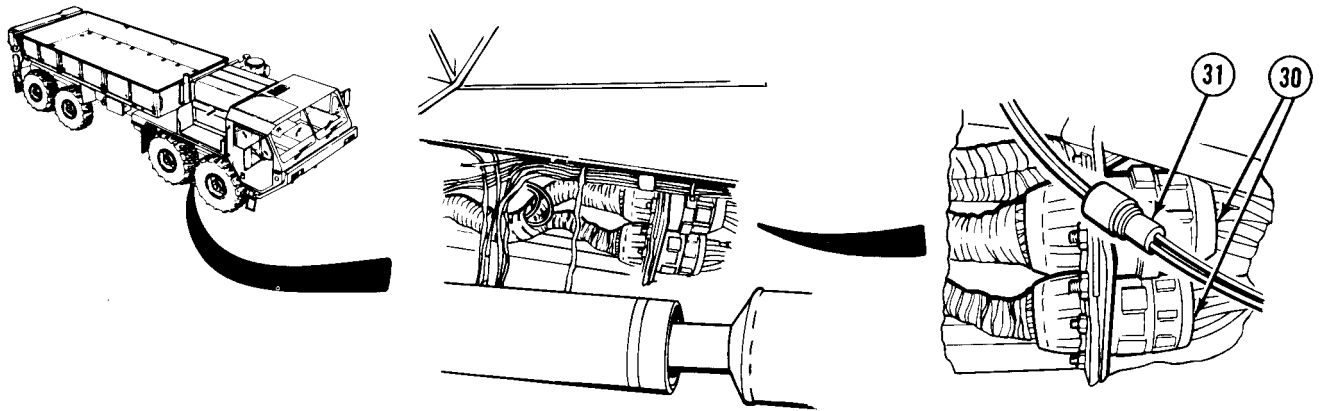

TA187646

- (27) Install two connectors (30).
- (28) Install connector (31).

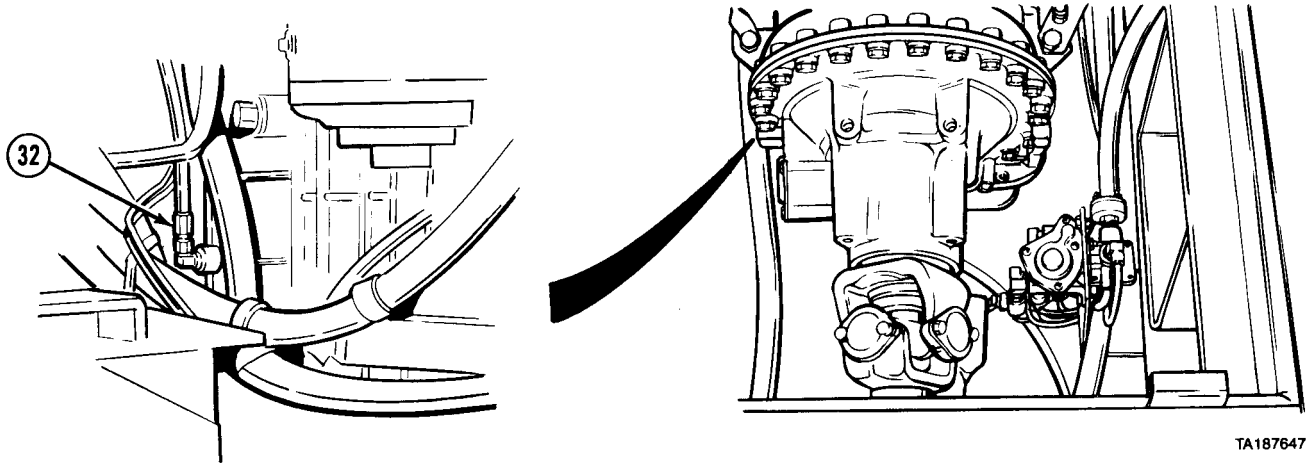

TA187647

NOTE

Clamps and plastic cable ties should be installed, as needed, when hoses and wires are connected.

- (29) Connect hose (32).

Engine Maintenance Instructions (Cont)

3-3. ENGINE REMOVAL/INSTALLATION (CONT).

- (30) Connect two wires (33 and 34) using electrical butt connectors (35).
- (31) Connect plug (36) to PTO pressure switch (37).
- (32) Connect plug (38) under hydraulic hose (39).

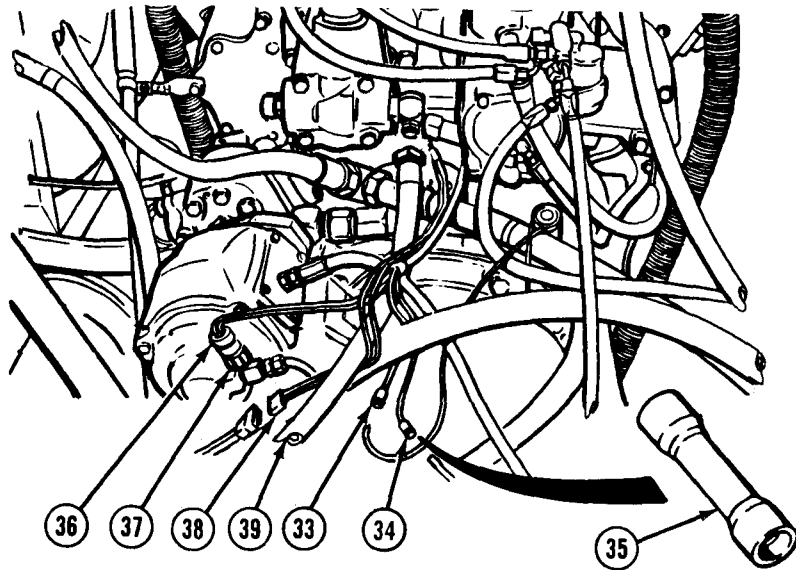

TA187648

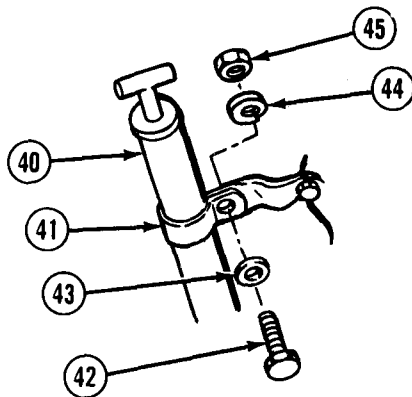

TA187649

- (33) Install transmission dipstick tube (40) and clamp (41) with screw (42), washer (43), lockwasher (44), and nut (45).

Engine Maintenance Instructions (Cont)

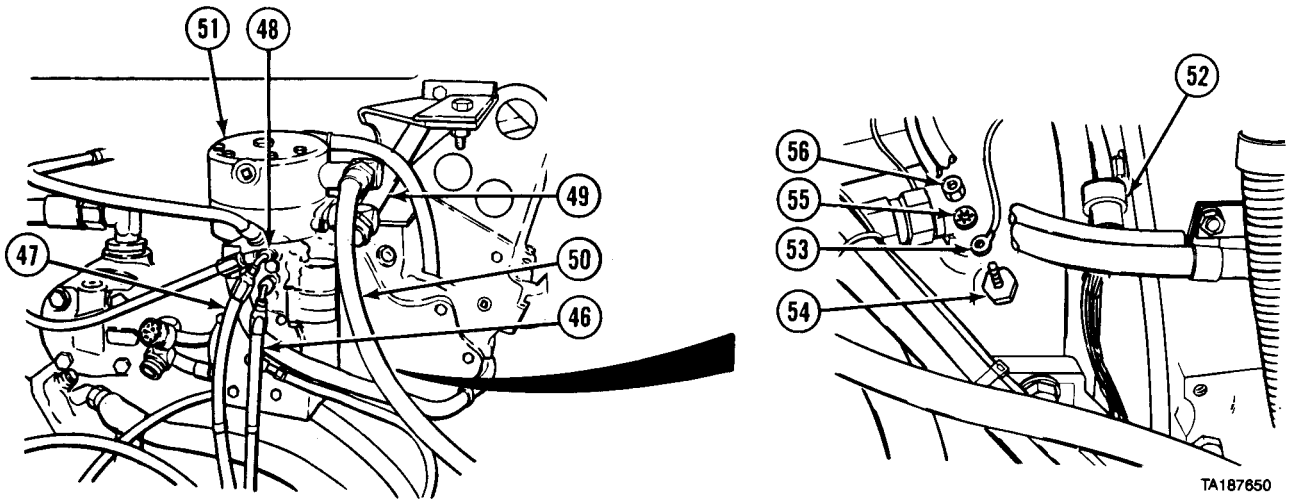

- (34) Connect two hoses (46 and 47) to governor (48).
- (35) Connect hoses (49 and 50) to air compressor (51).
- (36) Connect STE/ICE connector (52).
- (37) Install wire (53) on temperature sending unit (54) with lockwasher (55) and nut (56).

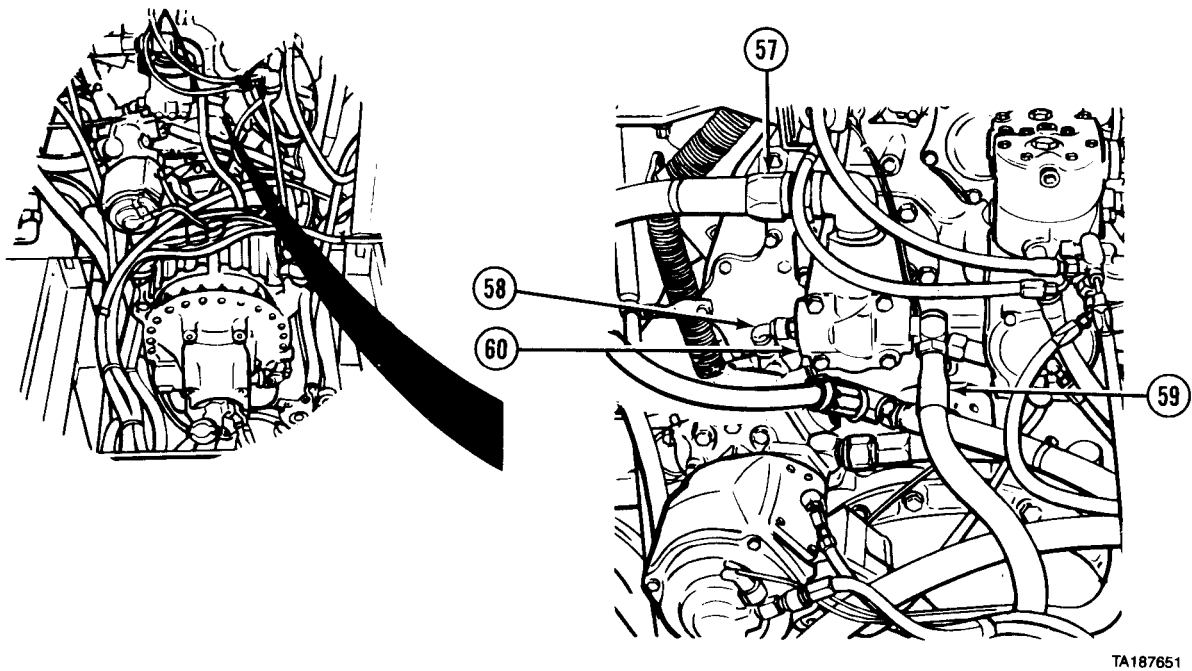

- (38) Connect three hoses (57, 58, and 59) to steering pump (60).

Engine Maintenance Instructions (Cont)

3-3. ENGINE REMOVAL/INSTALLATION (CONT).

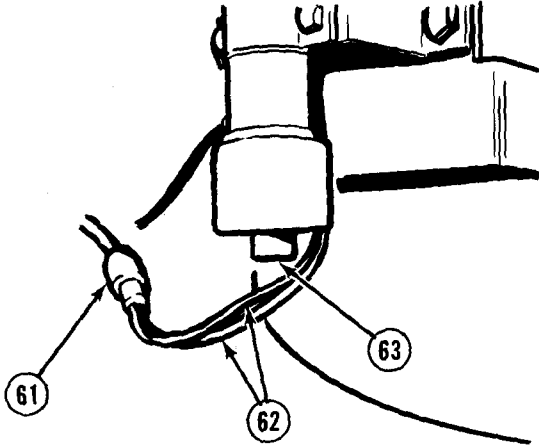

(39) Connect plug (61) to wires (62) at ether starting aid (63).

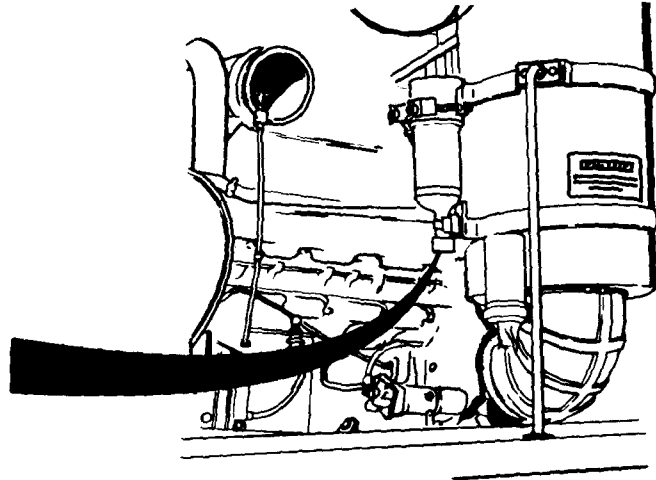

TA187652

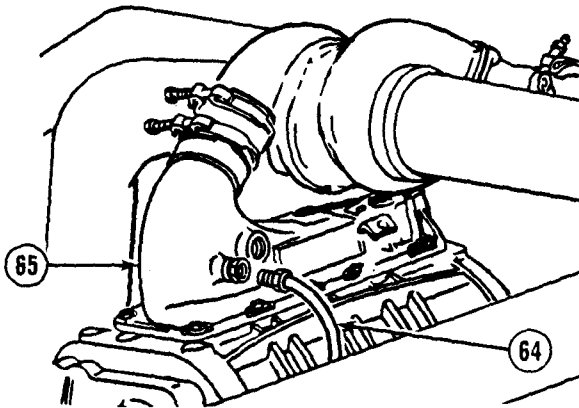

(40) Connect ether starting aid tube (64) to air inlet housing (65).

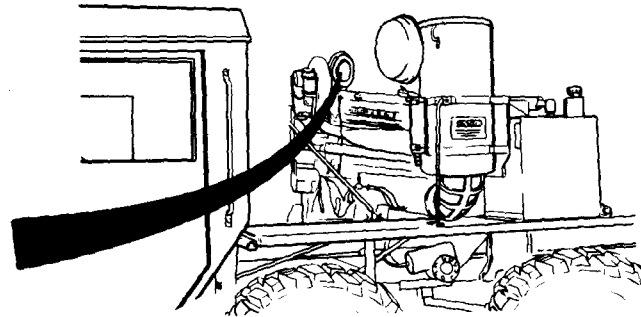

TA187653

Engine Maintenance Instructions (Cont)

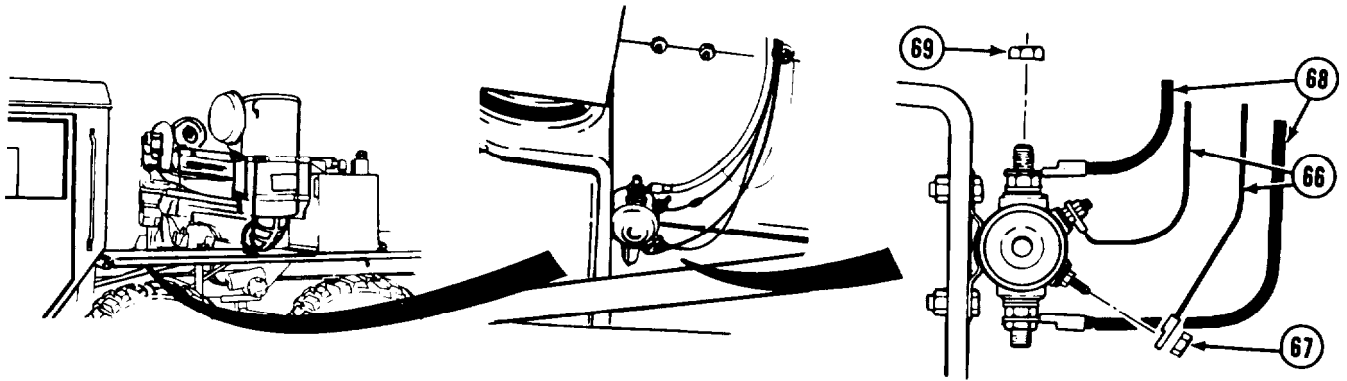

- (41) Install two wires (66) with two nuts (67)
- (42) Install two cables (68) with two nuts (69).

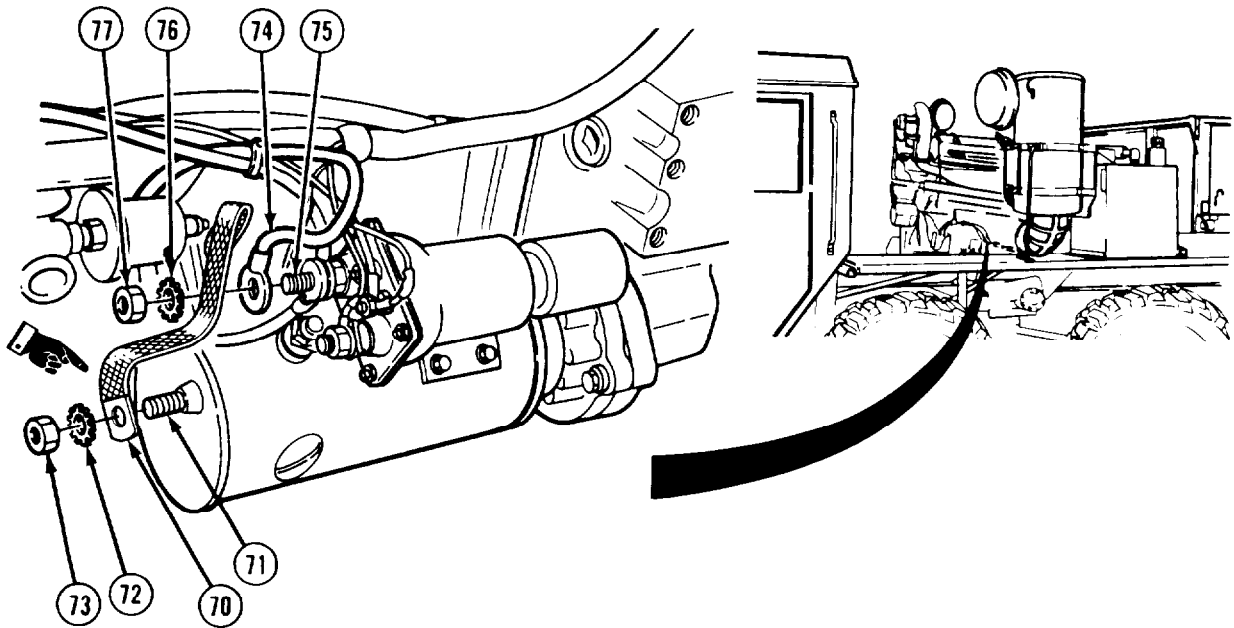

- (43) Install seven starter wires (70) on stud (71) with washer (71.1) lockwasher (72) and nut (73).
- (44) Install five solenoid wires (74) on stud (75) with lockwasher (76) and nut (77).

Engine Maintenance Instructions (Cont)

3-3. ENGINE REMOVAL/INSTALLATION (CONT).

- (45) Connect airhose (78).
- (46) Connect two fuel hoses (79 and 80).
- (47) Install three hoses (81, 82, and 83) and tighten clamps (84, 85, and 86).

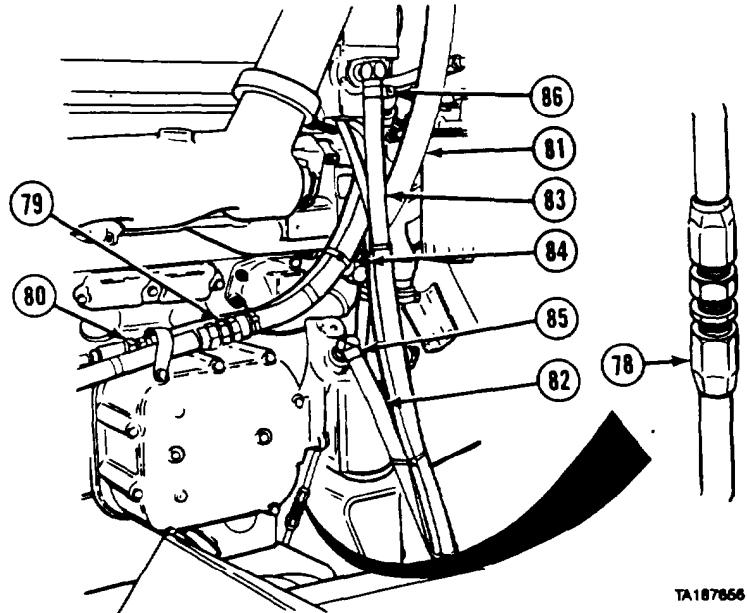

TA187856

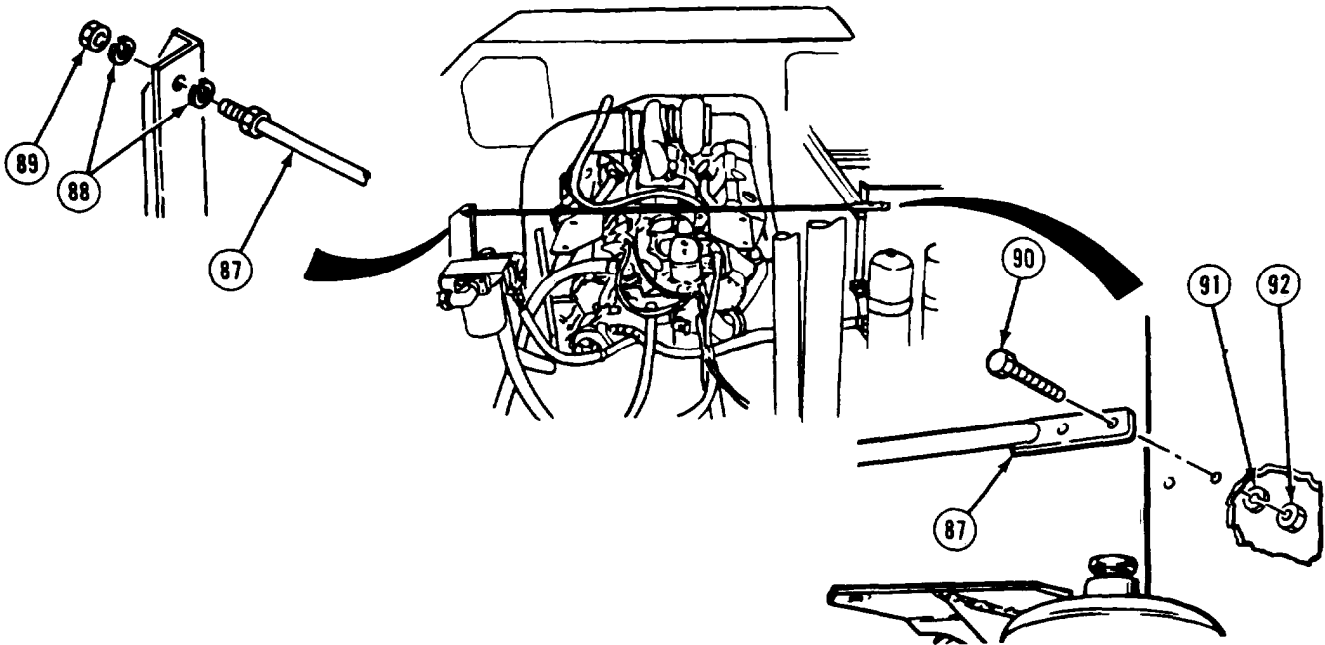

TA187857

- (48) Install one end of cross brace (87) with two lockwashers (88) and nut (89). Install other end of cross brace with two screws (90), lockwashers (91), and nuts (92).

Engine Maintenance Instructions (Cont)

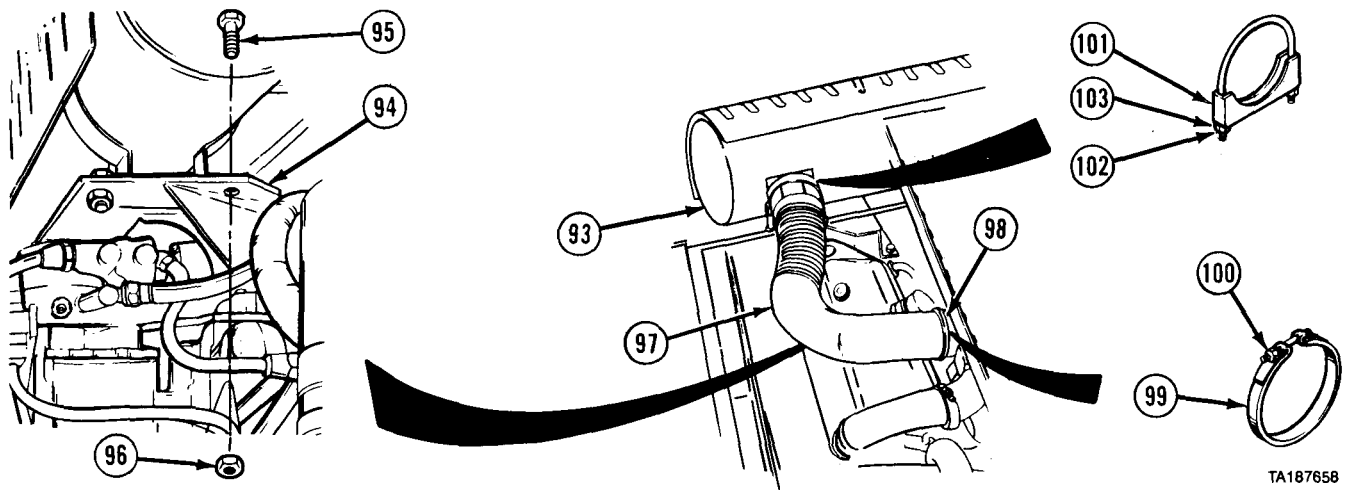

TA187658

- (49) Soldier A and Soldier B position muffler assembly (93) on brackets (94).
- (50) Install muffler assembly (93) with four screws (95) and nuts (96), but do not tighten.
- (51) Aline and install exhaust pipe (97) on muffler assembly (93) and turbocharger (98).
- (52) Install clamp (99) with nut (100).
- (53) Install clamp (101) with two nuts (102) and washers (103).
- (54) Tighten nuts (96).

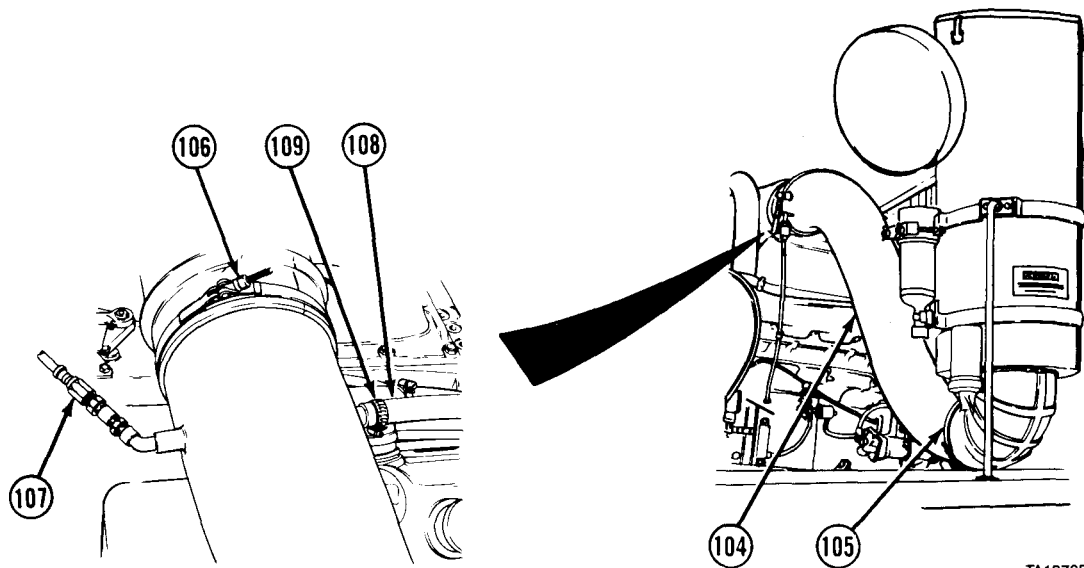

TA187659

- (55) Position air intake duct (104) and tighten clamps (105 and 106).
- (56) Install hose (107).
- (57) Install hose (108) and tighten clamp (109).

3-3. ENGINE REMOVAL/INSTALLATION (CONT).

c. Follow-on Maintenance.

- (1) Install slinging support assemblies (para 13-6).
- (2) Install radiator (TM 9-2320-279-20).
- (3) Install hoist end of tire davit (TM 9-2320-279-10).
- (4) Stow spare tire (TM 9-2320-279-10).
- (5) Install rear engine cover frame (TM 9-2320-279-20).
- (6) Connect batteries (TM 9-2320-279-20).
- (7) Fill radiator (TM 9-2320-279-20).
- (8) Fill engine with oil (LO 9-2320-279-12).
- (9) Fill hydraulic reservoir (LO 9-2320-279-12).
- (10) Check engine oil level (LO 9-2320-279-12).
- (11) Start engine and check operation (TM 9-2320-279-10).
- (12) Park vehicle (TM 9-2320-279-10).

END OF TASK

3-4. ENGINE TO ENGINE STAND INSTALLATION/REMOVAL.		
This task covers:		
a. Install Engine On Stand	c. Follow-on Maintenance	
b. Remove Engine From Stand		
INITIAL SETUP		
<i>Models</i>	<i>Equipment Condition</i>	
All	<i>TM or Para</i>	<i>Condition Description</i>
<i>Test Equipment</i>	TM 9-2815-224-	Exhaust manifold (left side
None	34&P	of engine only) removed.
<i>Special Tools</i>	TM 9-2815-224-	Air box covers (left side of
Engine stand J6837-C or J29109	34&P	engine only) removed.
Adapter plate J8601-01 or J33850	TM 9-2815-224-	Air box drain (left side of
	34&P	engine only) removed.
<i>Supplies</i>	TM 9-2320-279-20	Sender mounting bracket
Ties, cable, plastic, Item 65, Appendix C	Para 3-3	removed.
		Engine removed.
<i>Personnel Required</i>	<i>Special Environmental Conditions</i>	
MOS 63W, Wheel vehicle repairer (2)	None	
<i>References</i>	<i>General Safety Instructions</i>	
None	None	
	<i>Level of Maintenance</i>	
	General Support	

Engine Maintenance Instructions (Cont)

a. *Install Engine on Stand.*

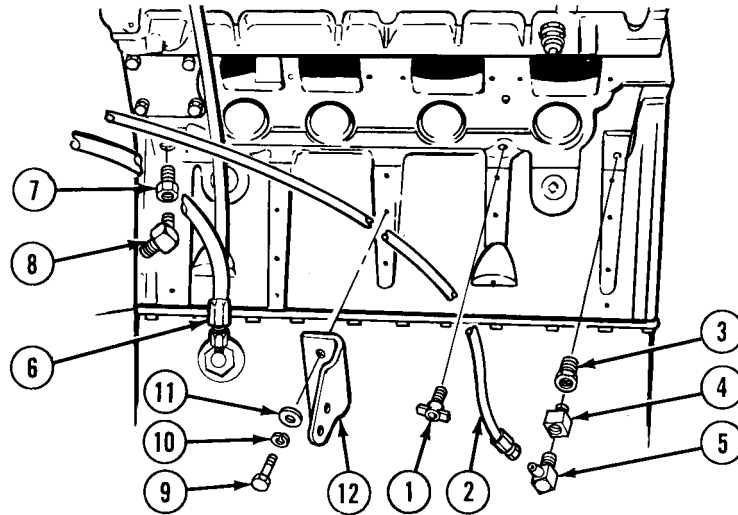

(1) Remove draincock (1).

NOTE

- Remove cushion clips and plastic cable ties as necessary.
- Tag and mark hoses before disconnecting.

(2) Disconnect hose (2) and remove reducer bushing (3), adapter (4), and elbow (5). Move oil return hose (6) out of way.

(3) Remove reducer bushing (7) and elbow (8).

(4) Remove two screws (9), lockwasher (10), washers (11), and starter mounting bracket (12).

(5) Disconnect oil return hose (6).

NOTE

Some engines have a copper washer. Other engines do not have a copper washer.

(6) Remove oil dipstick tube (13), adapter (14), and copper washer (14.1).

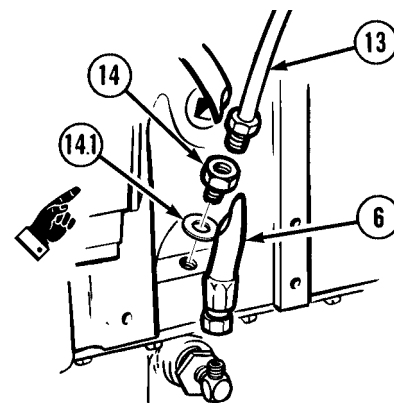

3-4. ENGINE TO ENGINE STAND INSTALLATION/REMOVAL (CONT).

(7) Install adapter plate with 13 screws (15).

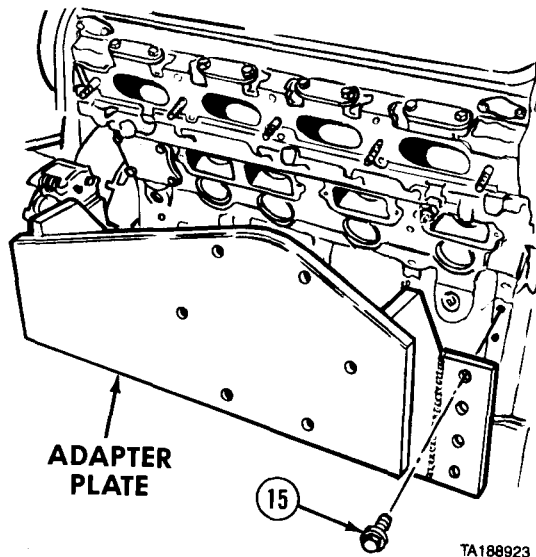

(8) Soldier A mounts engine (16) and adapter plate to engine stand with six screws (17) and washers (18) while Soldier B supports engine with suitable lifting device.

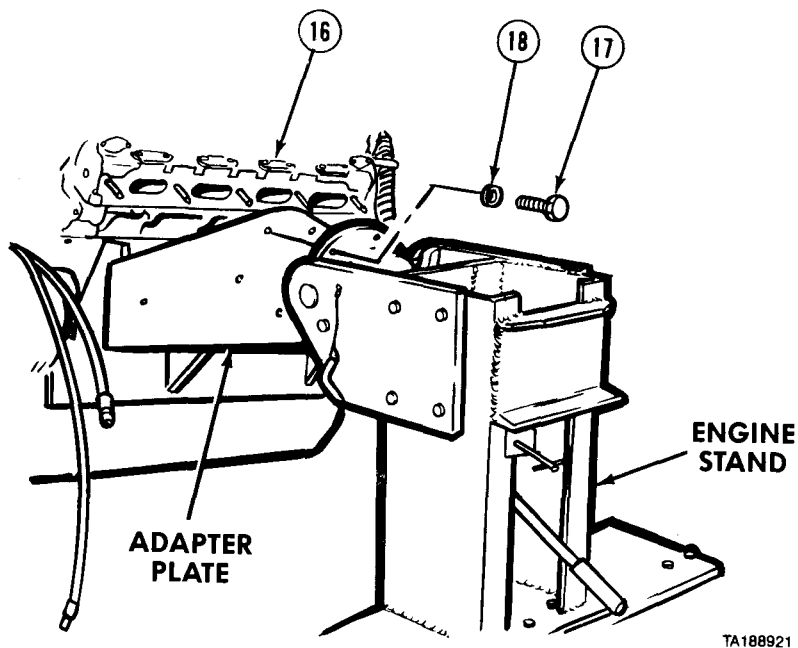

Engine Maintenance Instructions (Cont)

b. Remove Engine from Stand.

- (1) Soldier A removes six screws (1) and washers (2) from engine stand and adapter plate while Soldier B supports engine (3) with suitable lifting device.

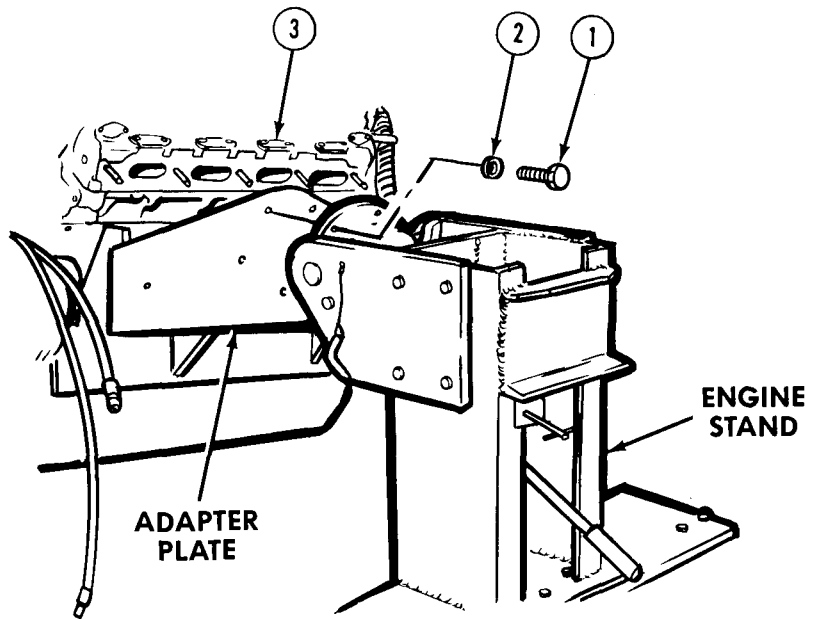

TA188924

- (2) Remove 13 screws (4) and adapter plate from engine (3).

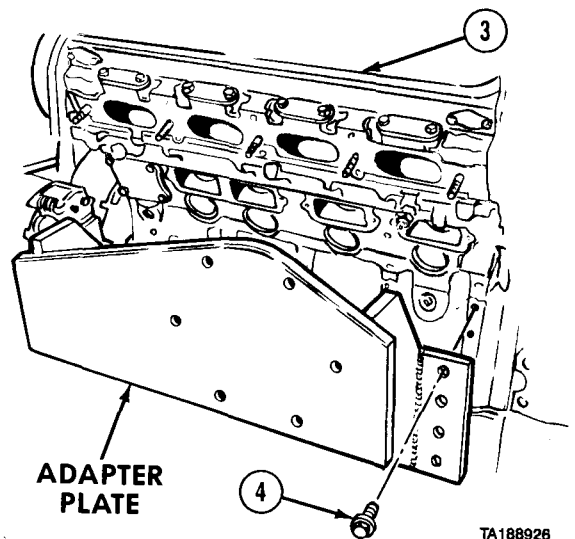

TA188926

Engine Maintenance Instructions (Cont)

3-4. ENGINE TO ENGINE STAND INSTALLATION/REMOVAL (CONT).

NOTE

Some engines have a copper washer. Other engines do not have a copper washer.

- (3) Install copper washer (4.1), adapter (5), and oil dipstick tube (6).
- (4) Connect oil return hose (7).

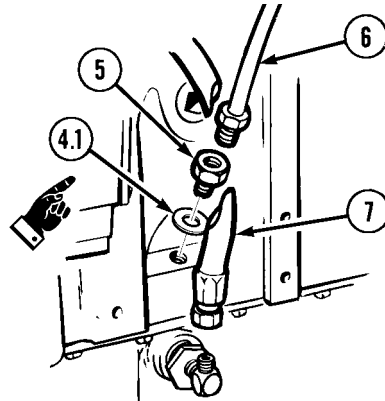

- (5) Install starter mounting bracket (8) with two screws (9), lockwasher (10), and washers (11).
- (6) Install reducer bushing (12) and elbow (13).
- (7) Install reducer bushing (14), adapter (15), and elbow (16).

NOTE

Install cushion clips and plastic cable ties as necessary.

- (8) Connect hose (17).
- (9) Install draincock (18).

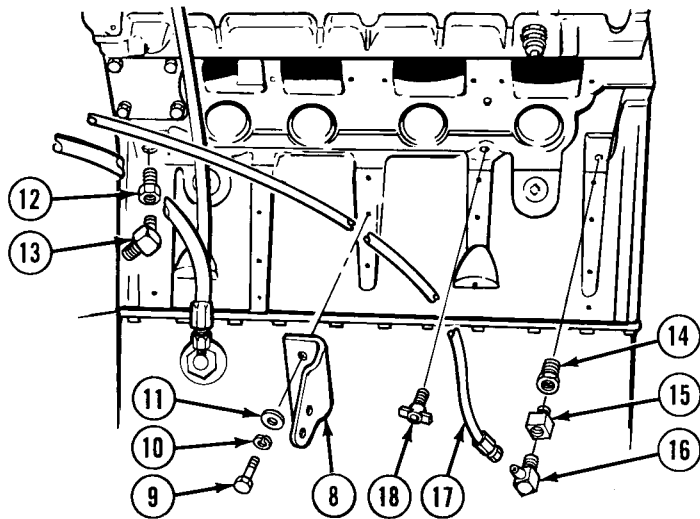

c. Follow-on Maintenance.

- (1) Install exhaust manifold (TM 9-2815-224-34&P).
- (2) Install air box covers (TM 9-2815-224-34&P).
- (3) Install air box drain (TM 9-2815-224-34&P).
- (4) Install sender mounting bracket (TM 9-2320-279-20).
- (5) Install engine (para 3-3).

END OF TASK

CHAPTER 4
FUEL SYSTEM MAINTENANCE

Contents	Para	Page
General	4-1	4-1
Throttle Treadle Valve Repair	4-2	4-1

Section I. INTRODUCTION

4-1. GENERAL This chapter contains maintenance instructions for repair of fuel system components at the direct support maintenance level. The subassemblies and parts which must be removed before fuel system components can be repaired are found in TM 9-2320-279-20.

Section II. THROTTLE TREADLE VAVLE

Fuel System Maintenance Instructions

4-2. THROTTLE TREADLE VALVE REPAIR.		
This task covers:		
<ul style="list-style-type: none"> a. Disassembly b. Cleaning/Inspection 	<ul style="list-style-type: none"> c. Assembly d. Follow-on Maintenance 	
INITIAL SETUP		
<i>Models</i>	<i>Equipment Condition</i>	
All	<i>TM or Para</i>	<i>Condition Description</i>
<i>Test Equipment</i>	Throttle treadle valve on clean work surface.	
None		
<i>Special Tools</i>	<i>Special Environmental Conditions</i>	
None	None	
<i>Supplies</i>	<i>General Safety Instructions</i>	
Solvent, dry cleaning, Item 57, Appendix C	None	
<i>Personnel Required</i>	<i>Level of Maintenance</i>	
MOS 63W, Wheel vehicle repairer	Direct Support	
<i>References</i>		
None		

4-2. THROTTLE TREADLE VALVE REPAIR (CONT).

a. Disassembly.

- (1) Remove two retaining rings (1), pin (2), spring (3), two bushings (4), and pedal (5).
- (2) Remove two retaining rings (6), pin (7), roller (8), and two bushings (9).

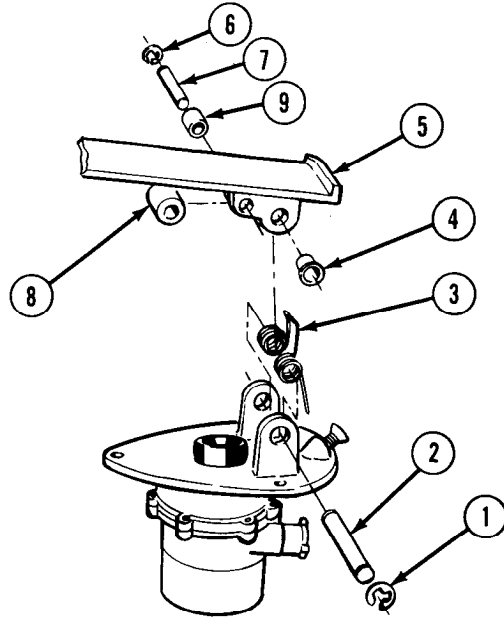

TA187444

- (3) Remove dust boot (10) and plunger (11).
- (4) Remove dust boot (10) from plunger (11).

NOTE

Matchmark mounting plate and control valve.

- (5) Remove nut (12) and mounting plate (13) from control valve (14).
- (6) Remove screw (15) from mounting plate (13).
- (7) Remove vent (16).

b. Cleaning/Inspection.

WARNING

Adhesives, solvents, and sealing compounds can burn easily, can give off harmful vapors, and are harmful to skin and clothing. To avoid injury or death, keep away from open fire and use in well-ventilated area. If adhesive, solvent, or sealing compound gets on skin or clothing, wash immediately with soap and water.

- (1) Clean all metal parts in dry cleaning solvent.
- (2) Check all metal parts for damage or corroded condition. Replace all damaged parts.

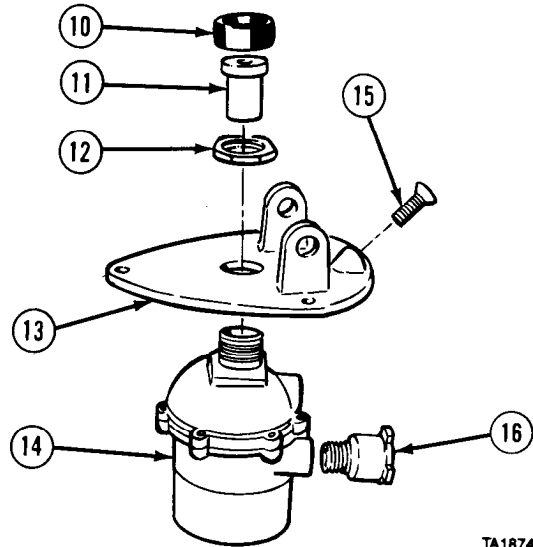

TA187445

Fuel System Maintenance Instructions (Cont)

c. Assembly.

- (1) Install vent (1).
- (2) Install screw (2) in mounting plate (3).
- (3) Aline matchmarks and install mounting plate (3) on control valve (4) with nut (5).
- (4) Install dust boot (6) on plunger (7).
- (5) Install plunger (7) and dust boot (6).

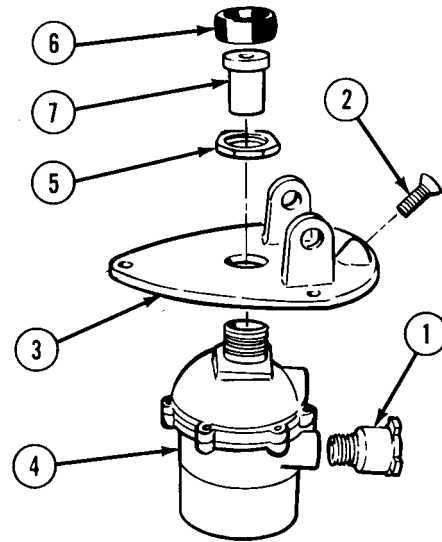

TA187446

- (6) Install two bushings (8), roller (9), pin (10), and two retaining rings (11) on pedal (12).
- (7) Install pedal (12) with two bushings (13) and pin (14).
- (8) Adjust screw (2) so roller (9) is just barely touching plunger (7).
- (9) Remove pedal (12) and install spring (15).
- (10) Install pedal (12) with pin (14) and two retaining rings (16).

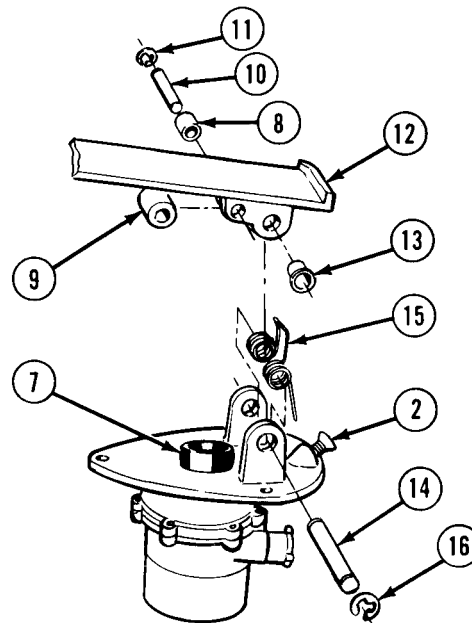

TA187447

d. Follow-on Maintenance. None.

END OF TASK

CHAPTER 5 COOLING SYSTEM MAINTENANCE

Contents	Para	Page
General	5-1	5-1
Radiator Repair	5-2	5-1

Section I. INTRODUCTION

5-1. GENERAL. This chapter contains maintenance instructions for repair of the cooling system at the direct support maintenance level. Subassemblies and parts which must be removed before cooling components can be repaired are found in TM 9-2320-279-20. The radiator is tube and fin type. The upper portion of the radiator assembly contains an expansion/fill tank.

Section II. RADIATOR

Cooling System Maintenance Instructions

5-2. RADIATOR REPAIR.

This task covers:

- | | |
|--|---|
| <ul style="list-style-type: none"> a. Disassembly b. Test and Repair | <ul style="list-style-type: none"> c. Assembly d. Follow-on Maintenance |
|--|---|

INITIAL SETUP

Models

All

Test Equipment

None

Special Tools

None

Supplies

Adhesive-sealant, silicone, Item 6, Appendix C
Cement, general purpose, Item 12, Appendix C

Personnel Required

MOS 63W, Wheel vehicle repairer

References

TM 750-254

Equipment Condition

TM or Para

Condition Description
Radiator on clean work surface.

Special Environmental Conditions

None

General Safety Instructions

None

Level of Maintenance

Direct Support

Cooling System Maintenance Instructions (Cont)

5-2. RADIATOR REPAIR (CONT).

a. Disassembly.

- (1) Remove six screws (1) and lockwashers (2) from sides of top tank assembly (3).
- (2) Remove 24 nuts (4), lockwashers (5), and screws (6) from front and back of top tank assembly (3).
- (3) Remove 30 nuts (7), lockwashers (8), screws (9), and two core washers (10).
- (4) Remove top tank assembly (3) and gasket (11) from radiator core (12).

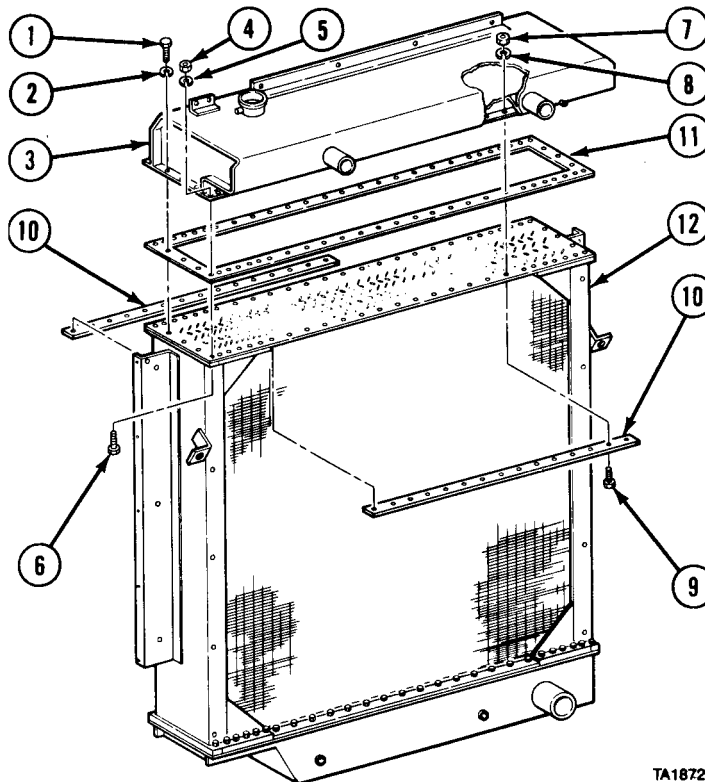

TA187285

- (5) Remove six screws (13) and lockwashers (14) from sides of bottom tank assembly (15).
- (6) Remove 24 nuts (16), lockwashers (17), and screws (18) from front and back of bottom tank assembly (15).
- (7) Remove 30 nuts (19), lockwashers (20), screws (21), and two core washers (22).
- (8) Remove bottom tank assembly (15) and gasket (23) from radiator core (12).

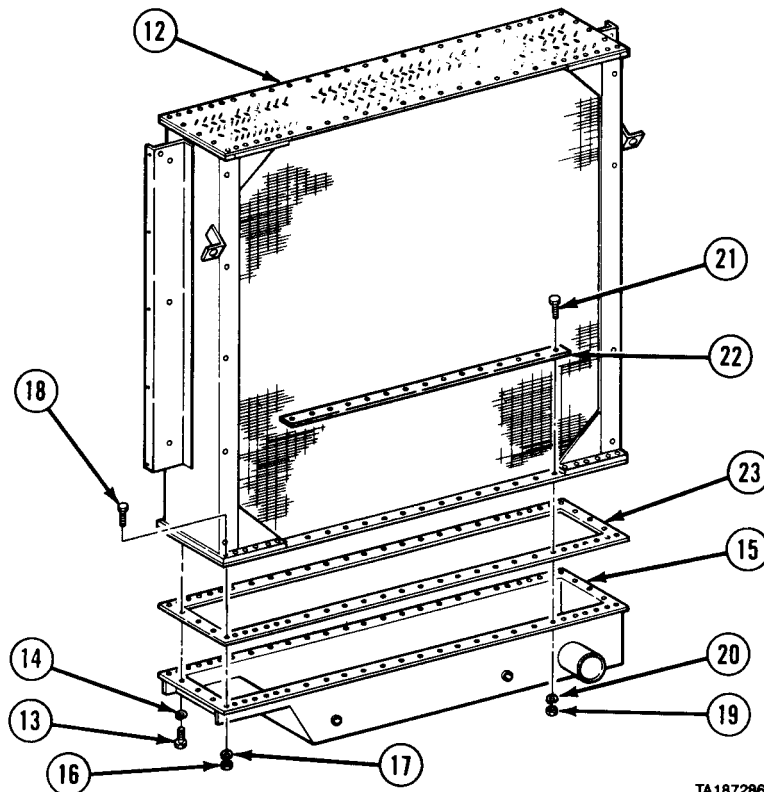

TA187286

Cooling System Maintenance Instructions (Cont)

- (9) Remove two sidemembers (24) and vibration dampeners (25) from radiator core (12).

b. Test and Repair. Radiator on clean work surface. To test and repair radiator, refer to TM 750-254.

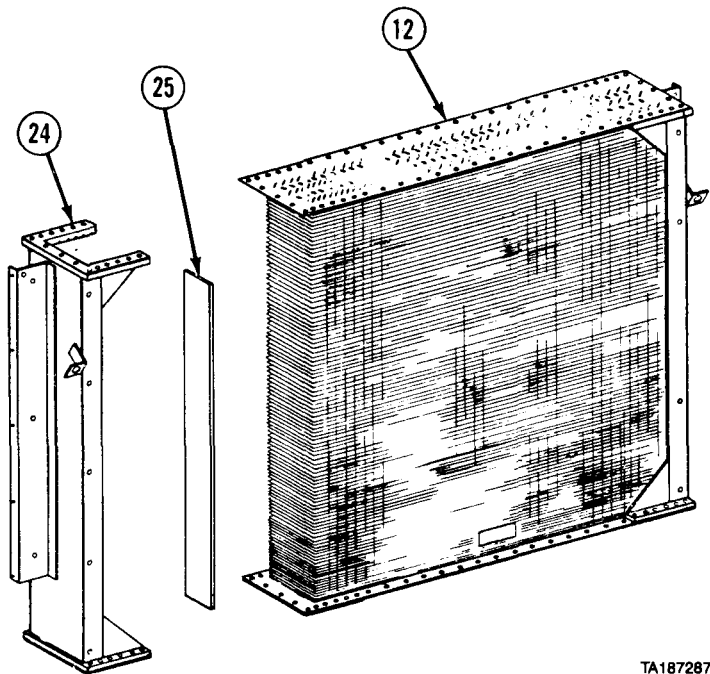

TA187287

c. Assembly.

WARNING

Adhesives, solvents, and sealing compounds can burn easily, can give off harmful vapors, and are harmful to skin and clothing. To avoid injury or death, keep away from open fire and use in well-ventilated area. If adhesive, solvent, or sealing compound gets on skin or clothing, wash immediately with soap and water.

NOTE

Bottom and rear of radiator core can be identified by plate at bottom of core and by manufacturer's tag at bottom rear of core.

- (1) Coat mating surfaces of two vibration dampeners (1) and sidemembers (2) with cement and install dampeners to sidemembers.
- (2) Install two sidemembers (2) on radiator core (3).

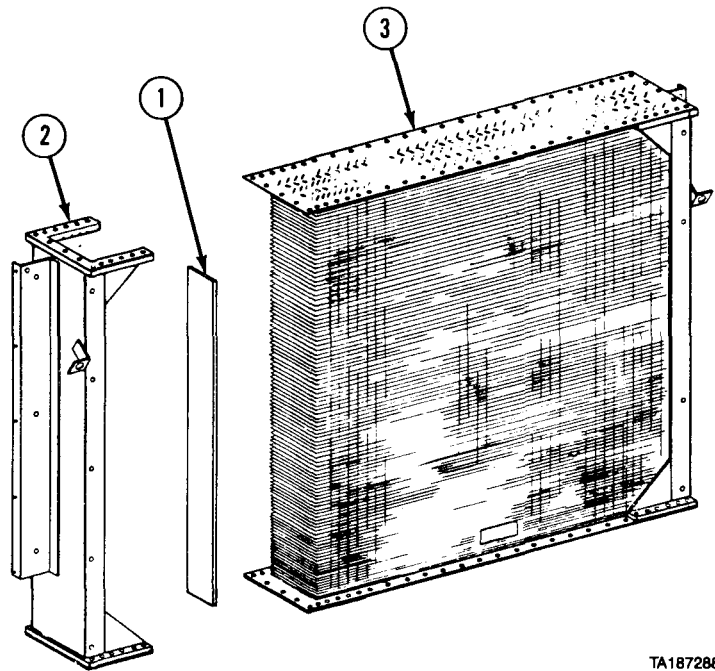

TA187288

Cooling System Maintenance Instructions (Cont)

5-2. RADIATOR REPAIR (CONT).

- (3) Coat gasket (4) and mating surface of bottom tank assembly (5) with silicone adhesive-sealant.
- (4) Install bottom tank assembly (5) and gasket (4) with six screws (6) and lockwashers (7). Do not tighten screws.
- (5) Install 24 screws (8), lockwashers (9), and nuts (10).
- (6) Install two core washers (11) with 30 screws (12), lockwashers (13), and nuts (14).
- (7) Tighten six screws (6).

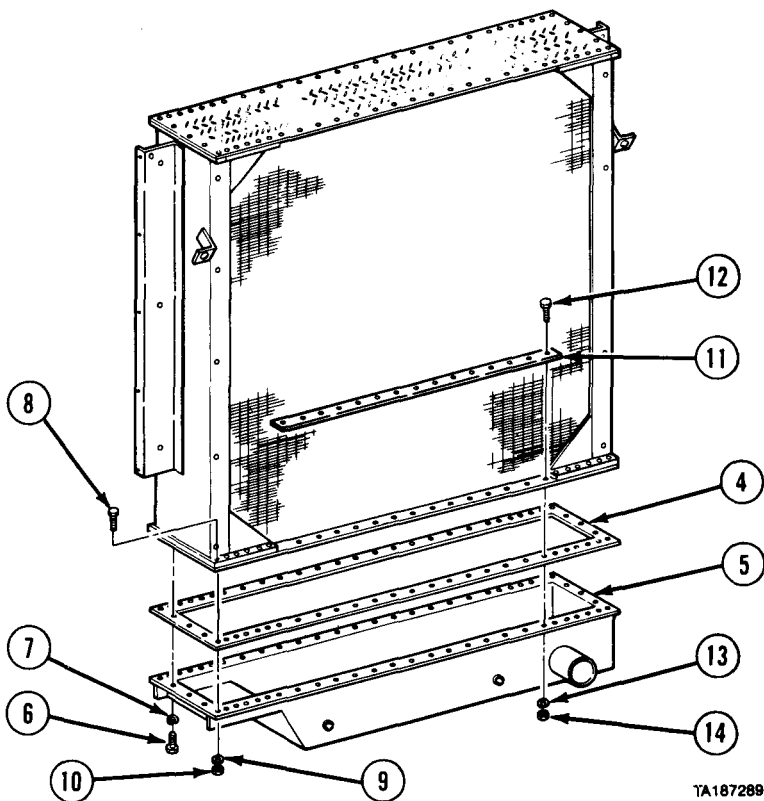

TA187289

- (8) Coat gasket (15) and mating surface of top tank assembly (16) with silicone adhesive-sealant.
- (9) Install top tank assembly (16) and gasket (15) with six screws (17) and lockwashers (18).
- (10) Install 24 screws (19), lockwashers (20), and nuts (21).
- (11) Install two core washers (22), 30 screws (23), lockwashers (24), and nuts (25).

d. Follow-on Maintenance. None.

END OF TASK

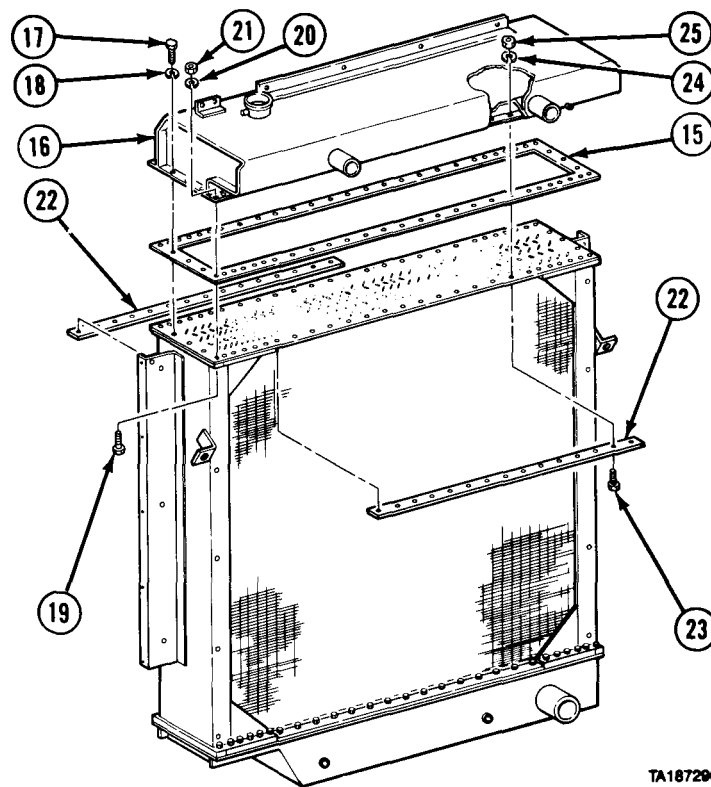

TA187290

CHAPTER 6 ELECTRICAL SYSTEM MAINTENANCE

Contents	Para	Page
General	6-1	6-1
Alternator Repair	6-2	6-2
24V Alternator Repair	6-2.1	6-14.1
Starter Solenoid Removal/Installation	6-3	6-15
Starter Motor Repair and Testing	6-4	6-19
Visual and Audible Level Warning Indicators Removal/Installation (M983)	6-5	6-36
Outrigger Extended Switch Removal/Installation (M983)	6-6	6-39
Tilt Warning Alarm Switch Removal/Installation (M983)	6-7	6-41
Crane Control Distribution Board Removal/Installation (M983)	6-8	6-44
Power Interconnecting Cables Removal/Installation (M983)	6-9	6-48
Tilt Alarm Box Removal/Installation (M983)	6-10	6-54
Junction Box and Connector Removal/Repair/Installation (M977, M985)	6-11	6-55
Junction Box and Connector Removal/Repair/Installation (M984E1)	6-11.1	6-64
Crane Overload Sensor Switches Removal/Installation (M977, M985)	6-12	6-64.6
Crane Overload Sensor Switches and Plate and Terminal Box Removal/Installation (M984E1)	6-12.1	6-70
Cab Wiring Harness Removal/Installation	6-13	6-70.8
Engine Wiring Harness Removal/Installation	6-14	6-87
Chassis Wiring Harness Removal/Installation	6-15	6-104
Chassis Wiring Harness Removal/Installation (M984E1)	6-15.1	6-122
Chassis/Engine Wiring Harness Removal/Installation	6-16	6-122.13
STE/ICE Wiring Harness Removal/Installation	6-17	6-125
High Mount Stop Lamp Harness Removal/Installation (M978)	6-18	6-131

Section I. INTRODUCTION

6-1. GENERAL. This chapter contains maintenance instructions for removal, installation, and repair of the electrical system components at the direct support maintenance level. Subassemblies and parts which must be removed before electrical system components and harnesses can be removed are referenced to other paragraphs or chapters of this manual or in TM 9-2320-279-20.

Section II. ALTERNATOR AND STARTER

Electrical System Maintenance Instructions (Cont)

6-2. ALTERNATOR REPAIR.

This task covers:

- | | |
|--|---|
| <ul style="list-style-type: none"> a. Disassembly b. Testing c. Cleaning/Inspection | <ul style="list-style-type: none"> d. Assembly e. Follow-on Maintenance |
|--|---|

INITIAL SETUP

Models
All

Test Equipment
None

Special Tools
None

Supplies
Solvent, drycleaning, Item 57, Appendix C
Compound, insulating, Item 20, Appendix C
Compound, sealing, lubricating, Item 25, Appendix C
Tags, identification, Item 60, Appendix C
Grease, automotive and artillery, Item 34, Appendix C

Personnel Required

MOS 63G, Fuel and electrical system repairer

References

None

Equipment Condition

<i>TM or Para</i>	<i>Condition</i>	<i>Description</i>
TM 9-2320-279-20	Alternator and pulley removed.	

TM 9-2320-279-20 Voltage regulator removed.

Special Environmental Conditions

None

General Safety Instructions

None

Level of Maintenance

Direct Support

a. Disassembly

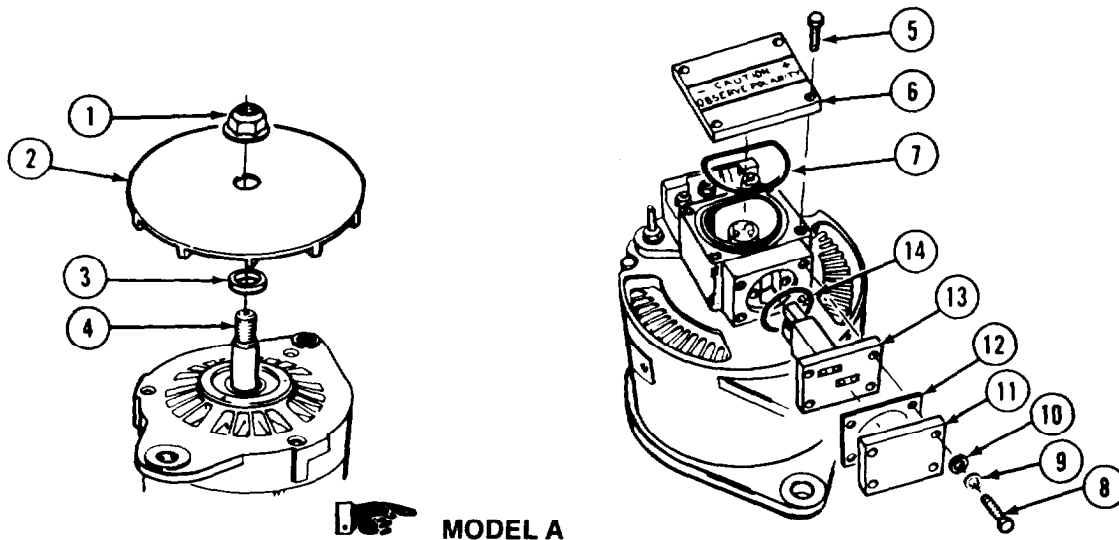

NOTE

There are two types of pulley used with the alternator. Model A has no key; Model B uses a key in the shaft keyway. Model A is shown.

- (1) Remove nut (1), fan (2), and fan spacer (3) from rotor shaft (4).
- (2) Remove four screws (5), cover (6), and preformed packing (7).
- (3) Remove four screws (8), lockwashers (9), guard washers (10), brush cover (11), and gasket (12).
- (4) Mark position of brush holder (13). Remove brush holder and preformed packing (14).

Electrical System Maintenance Instructions (Cont)

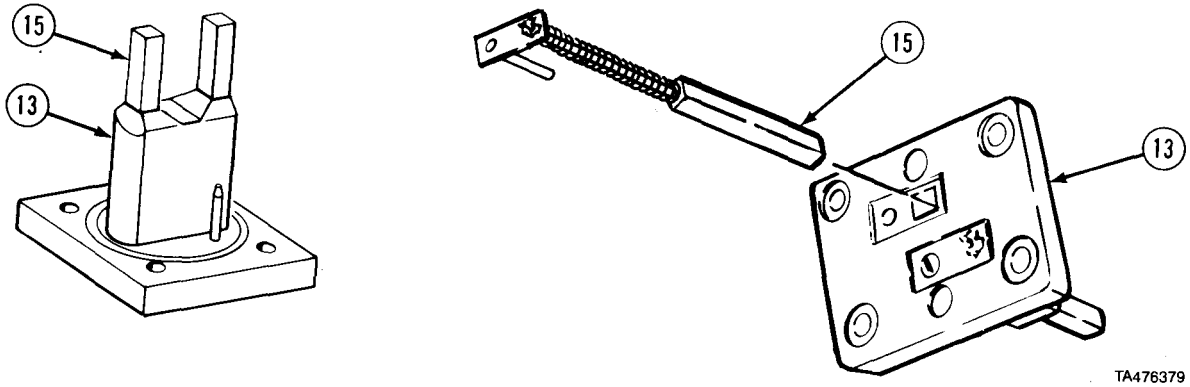

TA476379

- (5) Place brush holder (13) on flat surface.
- (6) Measure distance of two brushes (15) that stick out of brush holder (13). If brushes stick out less than 0.25 in. (6 mm), do step (7).
- (7) Remove two brushes (15) from brush holder (13).

- (8) Remove two screws (16) and insulator (17).
- (9) Pull brush holder adapter (18) from slipping end housing (19).
- (10) Mark brush holder adapter (18) and wires (20 and 21).
- (11) Remove two wires (20 and 21) from brush holder adapter (18).

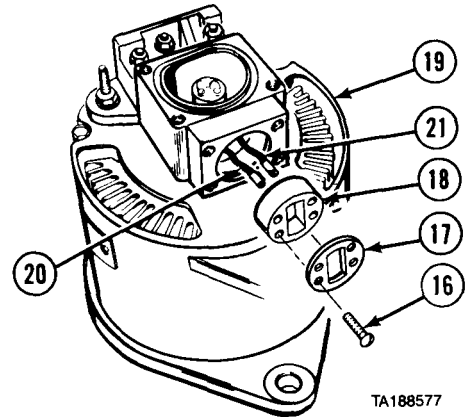

TA188577

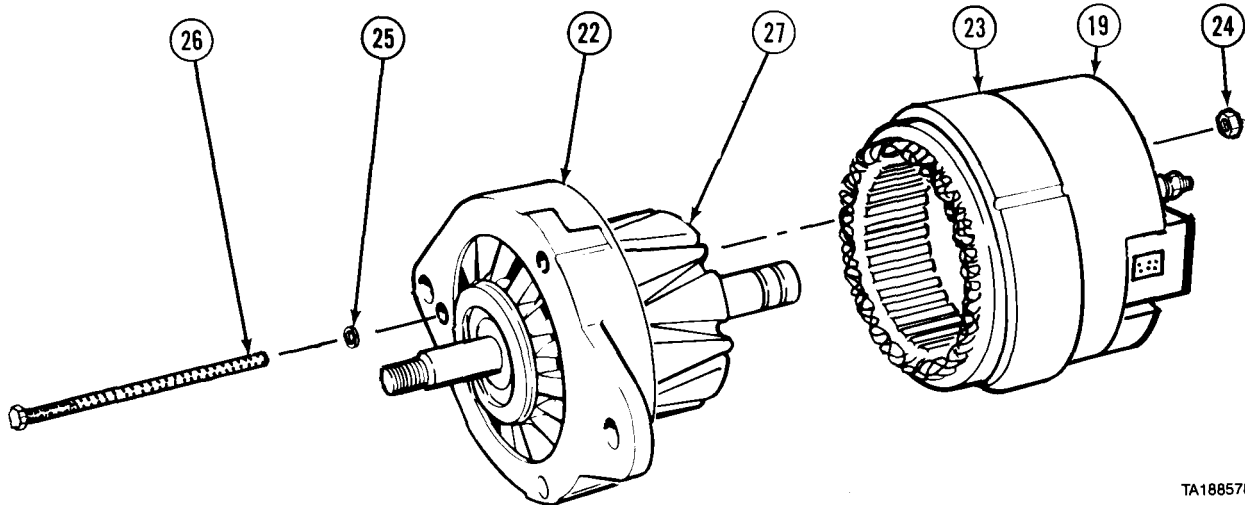

TA188578

- (12) Matchmark drive end housing (22), stator (23), and slipping end housing (19).
- (13) Remove three locknuts (24), washers (25), and screws (26).
- (14) Remove drive end housing (22) and rotor assembly (27) from stator (23).

6-2. ALTERNATOR REPAIR (CONT).

- (15) Remove four screws (28) and bearing retainer (29).
- (16) Remove seal (30) from bearing retainer (29).
- (17) Remove bearing (31) from drive end housing (22).

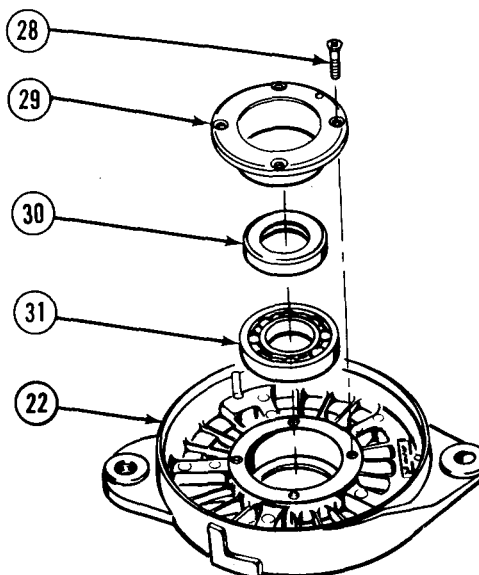

TA188580

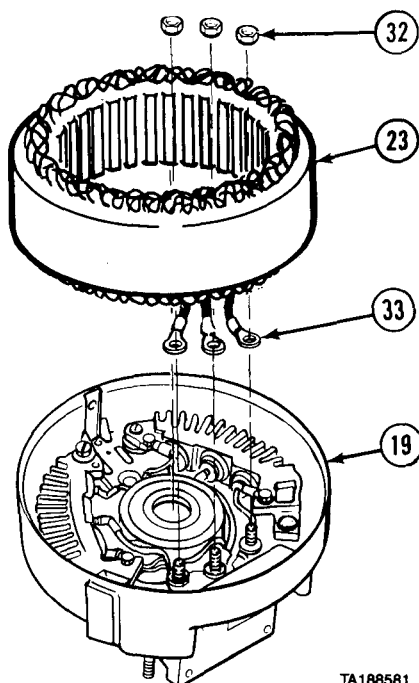

TA188581

- (18) Remove three tenz nuts (32).

NOTE

Tag and mark all wires.

- (19) Remove three wires (33) and stator (23) from slipring end housing (19).

Electrical System Maintenance Instructions (Cont)

(20) Remove three screws (34) and three wires (35).

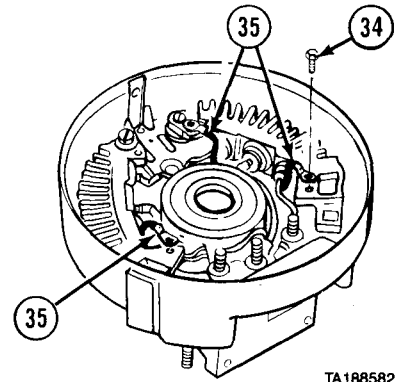

(21) Remove two tenz nuts (36 and 37) and terminal screws (38 and 39).

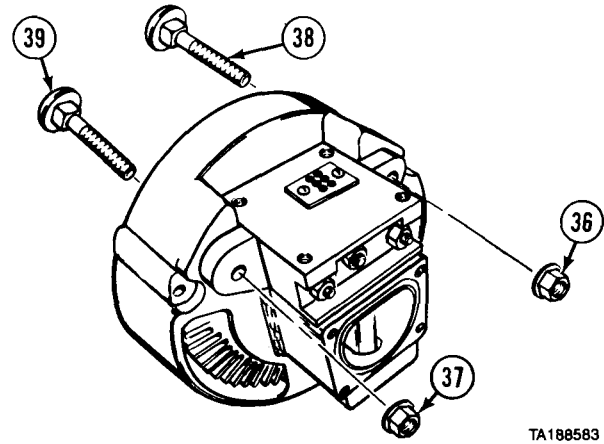

(22) Remove two screws (40), lockwashers (41), guard washers (42), and insulation washers (43).

(23) Tag and mark three rectifier wires (44) and three regulator connector wires (45).

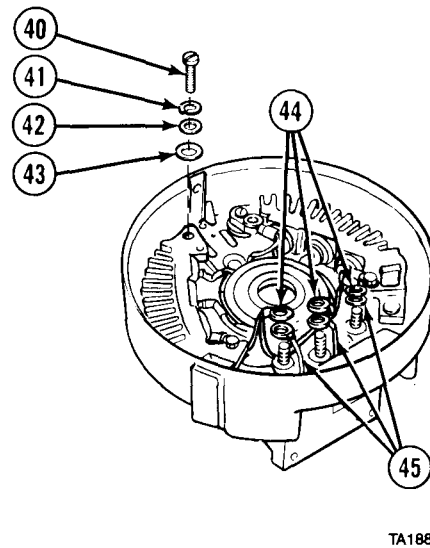

6-2. ALTERNATOR REPAIR (CONT).

- (24) Remove positive rectifier (46) and negative rectifier (47) as a unit from slipping end housing (19).
- (25) Remove two bushings (48) from rectifiers (46 and 47).
- (26) Remove two bushings (49 and 50) and bushings (51 and 52) from slipping end housing (19).

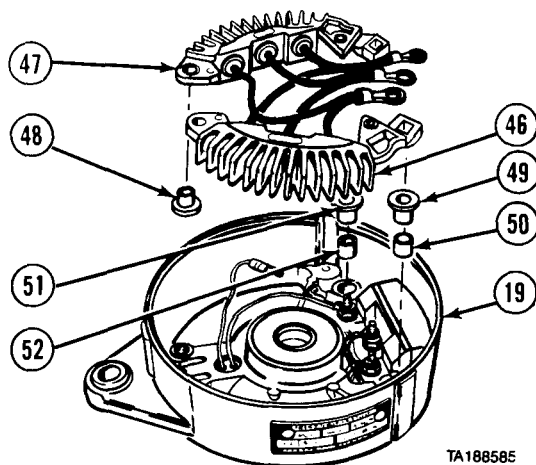

- (27) Remove two wires (20 and 21) and grommet (53). Remove grommet from wires.
- (28) Remove regulator holder (54) from slipping end housing (19).

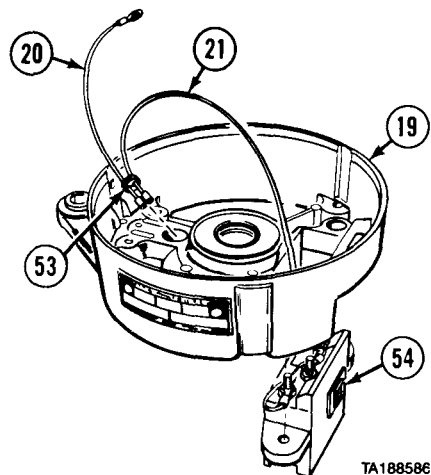

- (29) Remove seal (55), bearing (56), and seal (57) from slipping end housing (19).
- (30) Remove bushing (58) from slipping end housing (19).

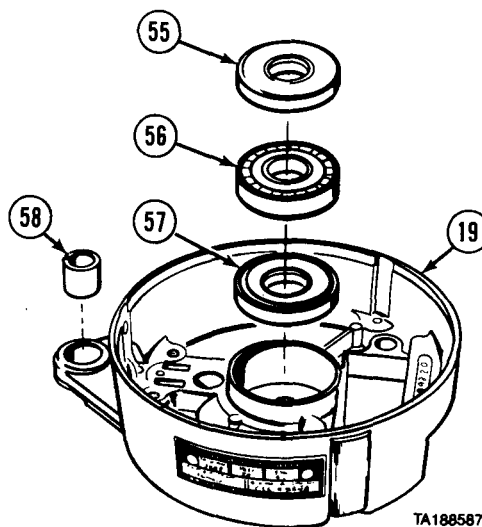

Electrical System Maintenance Instructions (Cont)

CAUTION

Mark position of connector assembly before removing. Damage to regulator may result if improperly installed.

- (31) Remove two screws (59) and connector assembly (60).
- (32) Remove three nuts (61) and lockwashers (62).
- (33) Remove three nuts (63), washers (64), and three terminal studs (65) from regulator holder (54).

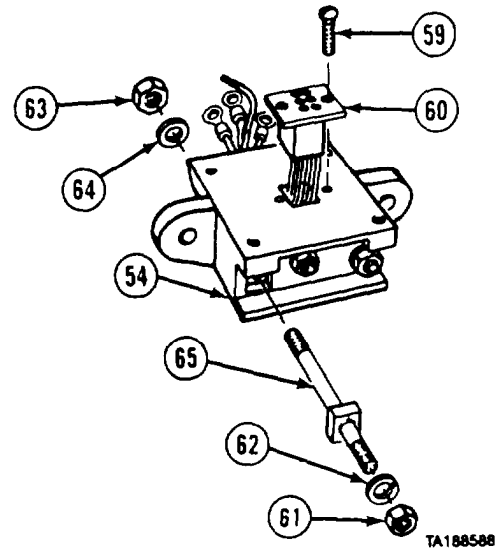

b. Testing.

- (1) Set multimeter to 10K range on RX scale. Touch negative (-) test lead to positive rectifier (1).
- (2) Touch positive (+) test lead to each of three eyelet terminals (2) in turn. If resistance is low, positive rectifier (1) is defective.
- (3) Connect positive (+) test lead to positive rectifier (1).
- (4) Touch negative (-) test lead to each of three eyelet terminals (2) in turn. If resistance is high, positive rectifier is defective.
- (5) Connect negative (-) test lead to negative rectifier (3).
- (6) Touch positive (+) test lead to each of three eyelet terminals (2) in turn. If resistance is high, negative rectifier (3) is defective.
- (7) Connect positive (+) test lead to negative rectifier (3).
- (8) Touch negative (-) test lead to each of three eyelet terminals (2). If resistance is low, negative rectifier (3) is defective.

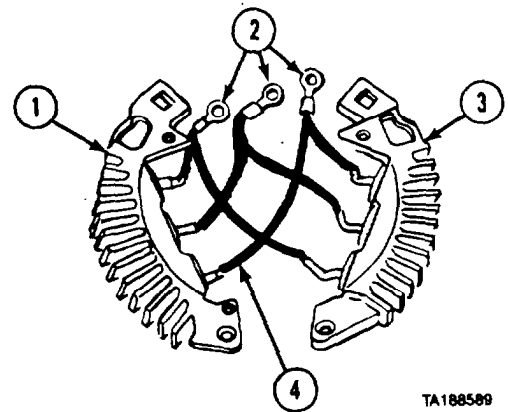

NOTE

- Perform step (9) only if positive or negative rectifier is bad.
 - When disconnecting rectifiers, cut wires from bad rectifier as close as possible to ring terminals.
- (9) Cut three wires (4) just below three eyelet terminals (2).
 - (10) Touch one test lead to bare metal surface on stator (5) and other test lead to each of three stator ring terminals (6, 7, and 8), in turn. Low resistance indicates stator is grounded. Replace stator.
 - (11) Touch test leads to stator ring terminals (6 and 7), (7 and 8), and (6 and 8), and read resistance across each set of terminals. If resistance is high, stator (5) is defective.

Electrical System Maintenance Instructions (Cont)

6-2. ALTERNATOR REPAIR (CONT).

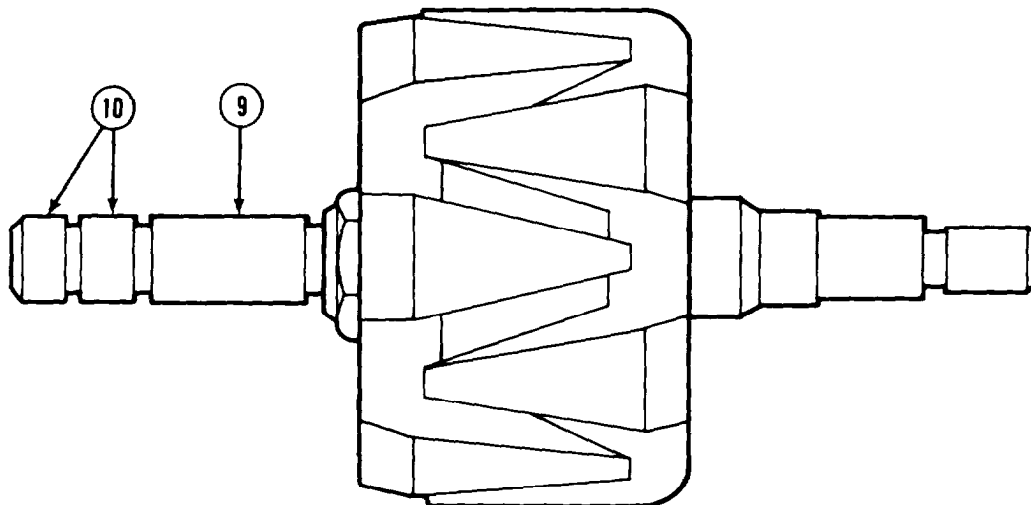

- (12) Connect test leads between shaft (9) and each slipring (10) consecutively. Low resistance in either test indicates rotor coil is grounded. Do not repair or further test alternator.
- (13) Connect test leads to each slipring (10). Resistance should be zero.
- (14) Measure diameter of sliprings (10). If less than 0.767 in. (19.48 mm), do not repair or further test alternator.
- (15) Measure diameter of shaft (9). If less than 0.871 in. (22.12 mm) do not repair or further test alternator.

C. Cleaning/Inspection.

WARNING

Adhesives, solvents, and sealing compounds can burn easily, can give off harmful vapors, and are harmful to skin and clothing. To avoid injury or death, keep away from open fire and use in well-ventilated area. If adhesive, solvent, or sealing compound gets on skin or clothing, wash immediately with soap and water.

CAUTION

To prevent damage to insulation, do not soak stator or rotor in solvents.

- (1) Clean stator and rotor with drycleaning solvent and clean cloth.

WARNING

Compressed air used for cleaning purposes will not exceed 30 psi (207 kPa). Use only with effective chip guarding and personal protective equipment, goggles, shield, and gloves.

- (2) Dry with compressed air or dry cloth.
- (3) Clean all other components, except bearings, in drycleaning solvent.
- (4) Inspect electrical assemblies for damage, frayed or bare wires, or loose connections.
- (5) Inspect mechanical assemblies for damage. Check for old or excess grease.
- (6) Clean rectifier assembly holes and terminal screws to ensure good electrical contact.

Electrical System Maintenance Instructions (Cont)

d. Assembly.

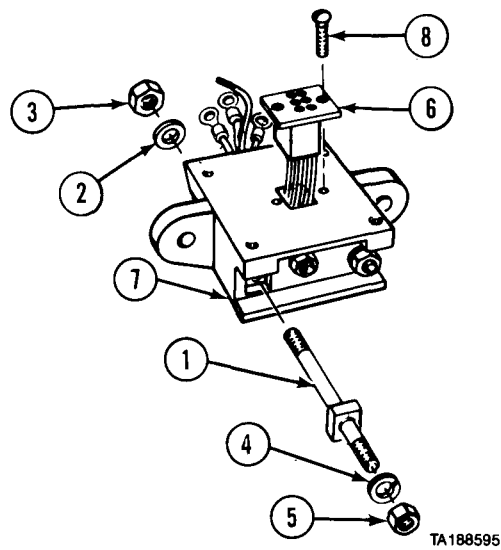

- (1) Install three terminal studs (1), washers (2), and nuts (3).
- (2) Install three lockwashers (4) and nuts (5) on terminal studs (1).

CAUTION

Install connector assembly as marked. Regulator can be damaged if improperly installed.

- (3) Install connector assembly (6) in regulator holder (7) with two screws (8).

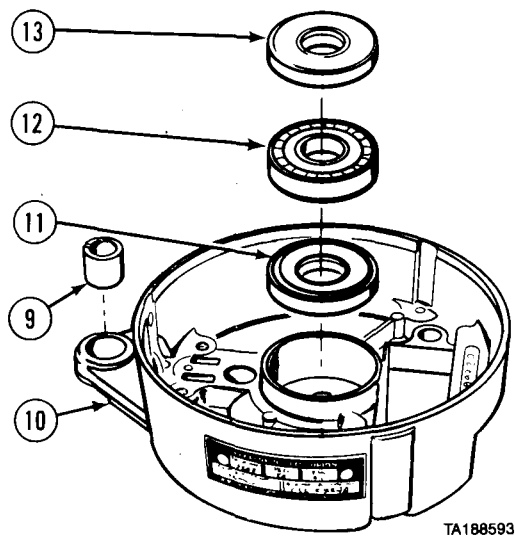

- (4) Install bushing (9) in slipring end housing (10).
- (5) Install seal (11), bearing (12), and seal (13).

Electrical System Maintenance Instructions (Cont)

6-2. ALTERNATOR REPAIR (CONT).

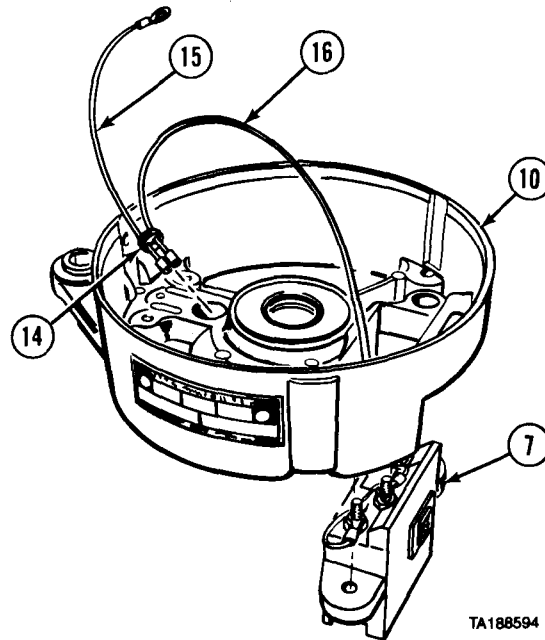

- (6) Install grommet (14) on two wires (15 and 16).
- (7) Install two wires (15 and 16) through slipping end housing (10) and install grommet (14).
- (8) Install regulator holder (7) in slipping end housing (10).

- (9) Install two bushings (17 and 18) and bushings (19 and 20) in slipping end housing (10).
- (10) Install two bushings (21) in rectifiers (22 and 23).
- (11) Install positive rectifier (22) and negative rectifier (23) as a unit into slipping end housing (10).

CAUTION

Wires from positive and negative rectifiers must be routed around, and flush with housing, or wires may be damaged during assembly.

NOTE

Do not install nuts.

- (12) Install three regulator connector wires (24) and three rectifier wires (25).

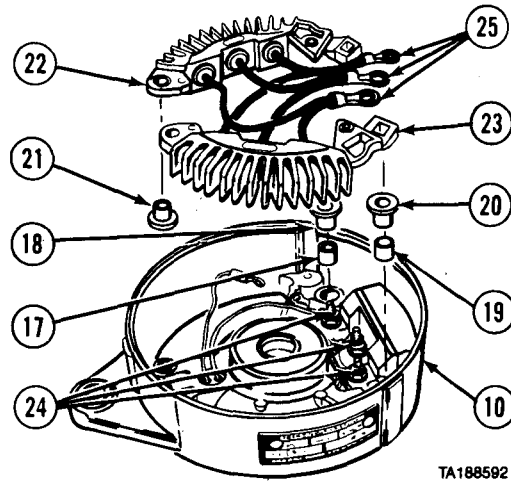

Electrical System Maintenance Instructions (Cont)

WARNING

Adhesives, solvents, and sealing compounds can burn easily, can give off harmful vapors, and are harmful to skin and clothing. To avoid injury or death, keep away from open fire and use in well-ventilated area. If adhesive, solvent, or sealing compound gets on skin or clothing, wash immediately with soap and water.

- (13) Apply sealing compound to threads of two screws (26). Install two insulation washers (27), guard washers (28), lockwashers (29), and screws. Do not tighten.
- (14) Apply insulating compound in and around square holes of rectifiers (22 and 23).

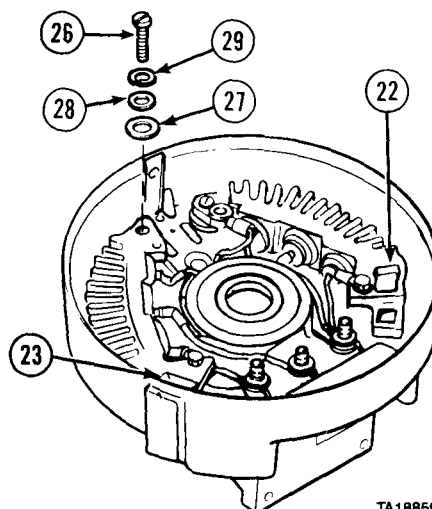

TA188596

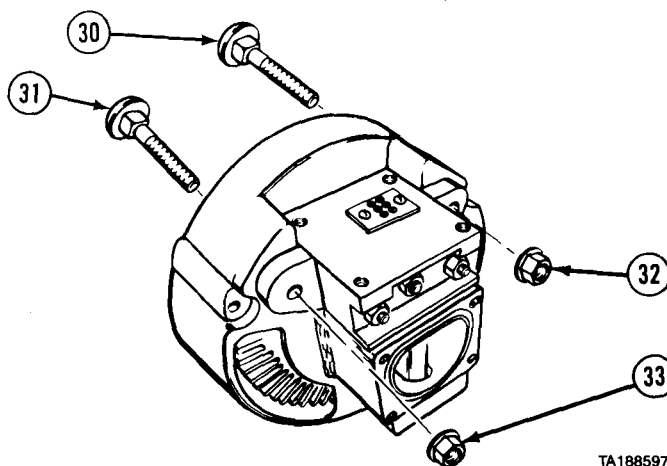

TA188597

- (15) Install two terminal screws (30 and 31) and tenz nuts (32 and 33).

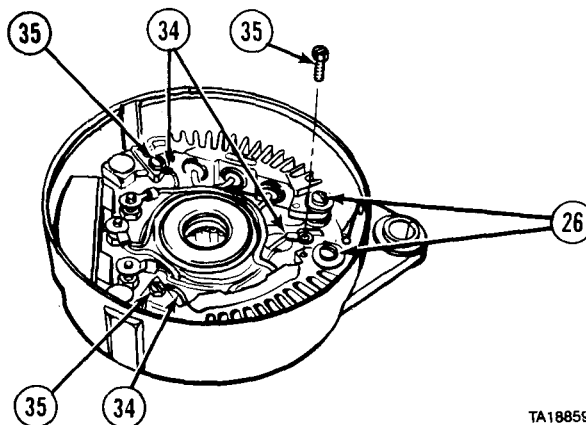

TA188598

- (16) Tighten two screws (26).
- (17) Install three wires (34) and screws (35).

6-2. ALTERNATOR REPAIR (CONT).

CAUTION

Handle stator carefully to prevent damage to windings.

- (18) Aline and install stator (36) on slipping end housing (10).
- (19) Install three wires (37) and tenz nuts (38) on terminal studs (1).

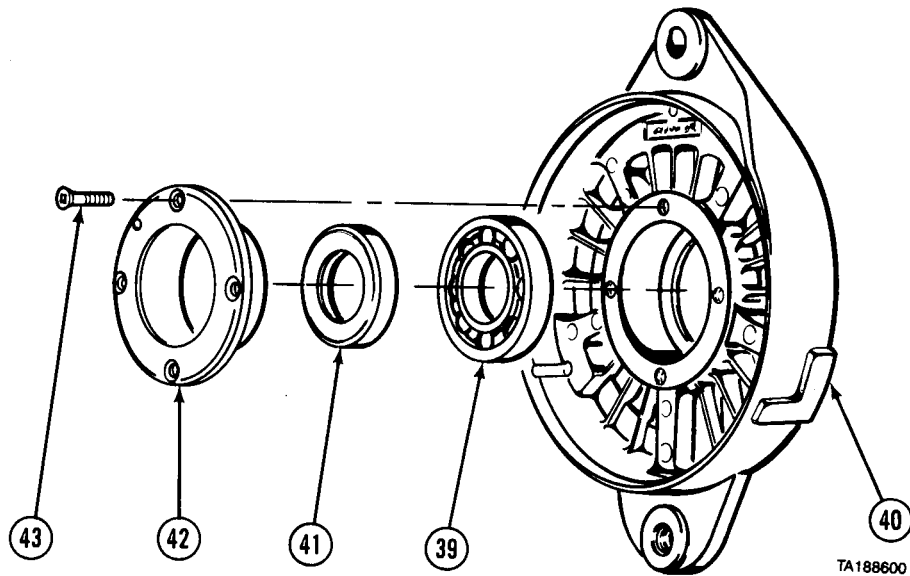
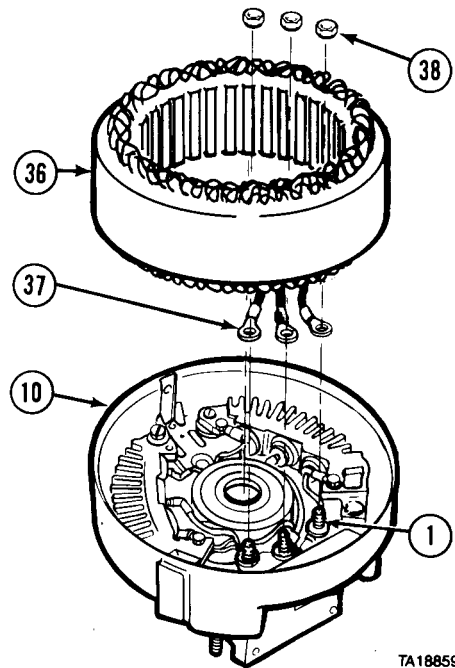

- (20) Pack bearing (39) with grease and install in drive end housing (40) with open side of bearing facing inward.
- (21) Press seal (41) into bearing retainer (42) until flat side of seal is flush with flat side bearing retainer.
- (22) Install bearing retainer (42) in drive end housing (40) with four screws (43).

Electrical System Maintenance Instructions (Cont)

- (23) Install rotor assembly (44) in drive end housing (40).

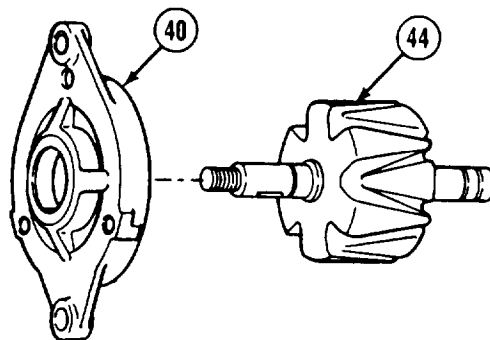

TA188601

- (24) Aline marks and install drive end housing (40) on stator (36).
- (25) Install three washers (45), screws (46), and locknuts (47).

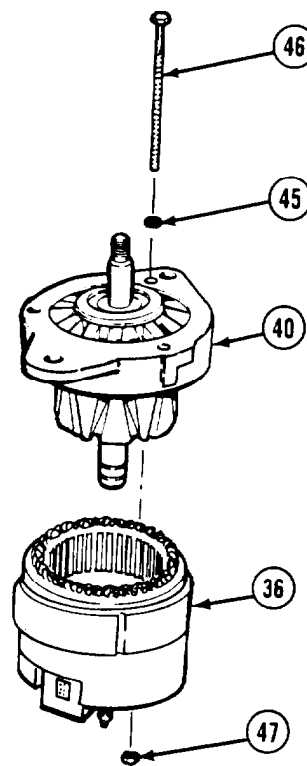

TA188602

- (26) Install two wires (15 and 16) into brush holder adapter (48).
- (27) Install brush holder adapter (48) and insulator (49) with two screws (50).

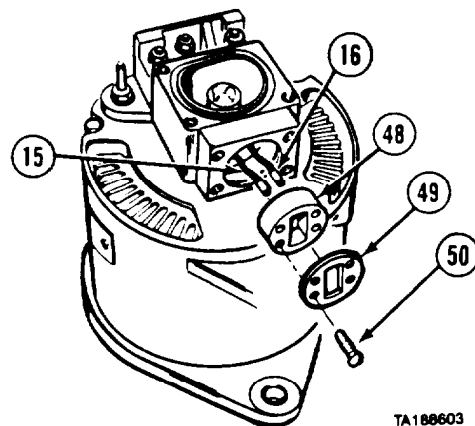

TA188603

Electrical System Maintenance Instructions (Cont)

6-2. ALTERNATOR REPAIR (CONT).

(28) Install two brushes (51) in brush holder (52).

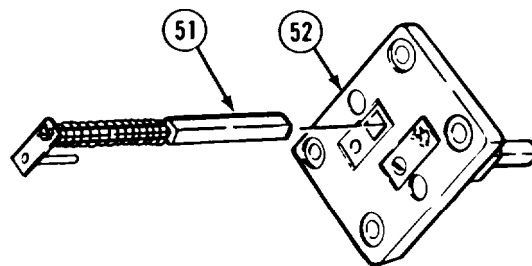

- (29) Install preformed packing (53) and brush holder (52).
- (30) Install gasket (54), brush cover (55), four guard washers (56), lockwashers (57), and screws (58).

CAUTION

Wires can be shorted out if rubbing on shaft.

(31) Install preformed packing (59) and cover (60) with four screws (61).

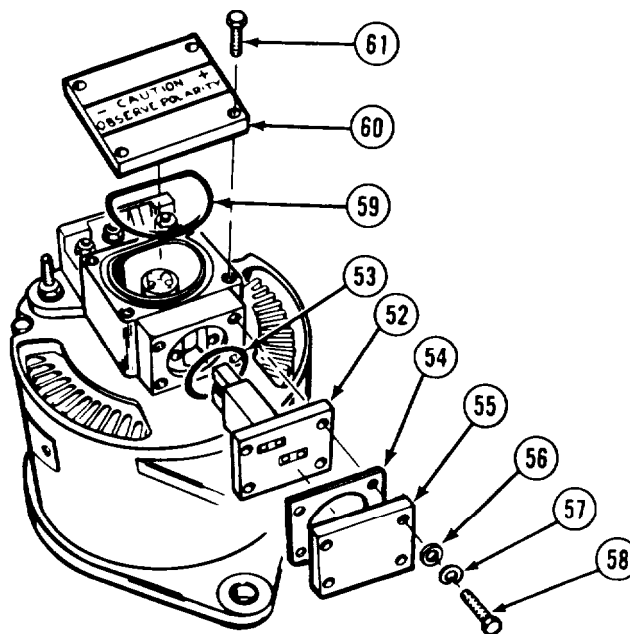

NOTE

Spacer is installed with notch facing away from housing.

(32) Install fan spacer (62) and fan (63) on rotor shaft (64) with nut (65).

e. Follow-on Maintenance.

- (1) Test on test stand (TM 9-2920-225-34).
- (2) Install voltage regulator (TM 9-2320-279-20).
- (3) Install alternator and pulley (TM 9-2320-279-20).

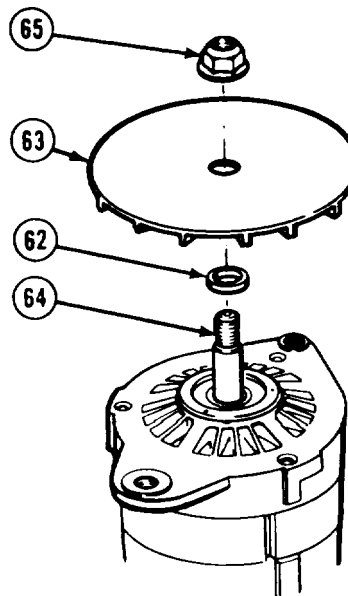

END OF TASK

Electrical System Maintenance Instructions (Cont)

6-2.1. 24V ALTERNATOR REPAIR.	
This task covers:	
<ul style="list-style-type: none"> a. Disassembly b. Testing c. Cleaning/Inspection 	<ul style="list-style-type: none"> d. Assembly e. Follow-on Maintenance
<p>INITIAL SETUP</p> <p><i>Models</i> All</p> <p><i>Test Equipment</i> None</p> <p><i>Special Tools</i> None</p> <p><i>Supplies</i> Solvent, drycleaning, Item 57, Appendix C Compound, insulating, Item 20, Appendix C Compound, sealing, lubricating, Item 25, Appendix C Tags, identification, Item 60, Appendix C Grease, automotive and artillery, Item 34, Appendix C</p>	<p><i>Personnel Required</i> MOS 63G, Fuel and electrical system repairer</p> <p><i>References</i> None</p> <p><i>Equipment Condition</i> <i>TM or Para</i> <i>Condition Description</i> TM 9-2320-279-20 Alternator removed.</p> <p><i>Special Environmental Conditions</i> None</p> <p><i>General Safety Instructions</i> None</p> <p><i>Level of Maintenance</i> Direct Support</p>

a. **Disassembly.**

- (1) Remove nut (1) from ignition (IGN) stud
- (2) on regulator holder (3).

CAUTION

Voltage regulator is still connected by two wires. Regulator cannot be removed until after step (5). Failure to comply may result in damage to alternator.

- (2) Remove four screws (4) and voltage regulator (5) from regulator holder (3).
- (3) Remove ignition (IGN) stud (2) and blue wire (6) from regulator holder (3).
- (4) Remove nut (7), lockwasher (8), and black wire (9) from negative (-) terminal of voltage regulator (5).
- (5) Remove nut (10), lockwasher (11), and red wire (12) from positive (+) terminal of voltage regulator (5).
- (6) Remove voltage regulator (5) and gasket (13) from alternator (14).
- (7) Remove two brushes (15) from regulator holder (3).

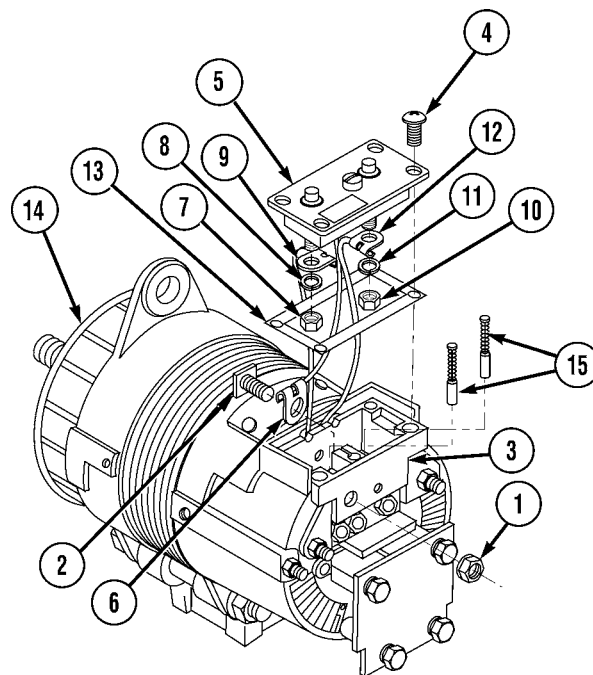

Electrical System Maintenance Instructions (Cont)

6-2.1. 24-VOLT ALTERNATOR REPAIR (CONT).

NOTE

Vise is used to securely hold pulley for step (9).

- (8) Position alternator (14) in vise.
- (9) Remove locknut (16) from shaft (17).
- (10) Remove alternator (14) from vise.
- (11) Remove pulley (18) from shaft (17).
- (12) Remove cooling plate (19), key (20), and spacer (21) from shaft (17).
- (13) Remove screw (22), lockwasher (23), and clip (24) from slip ring end housing (25).
- (14) Remove three nuts (26) and wires (27) from terminals (28).

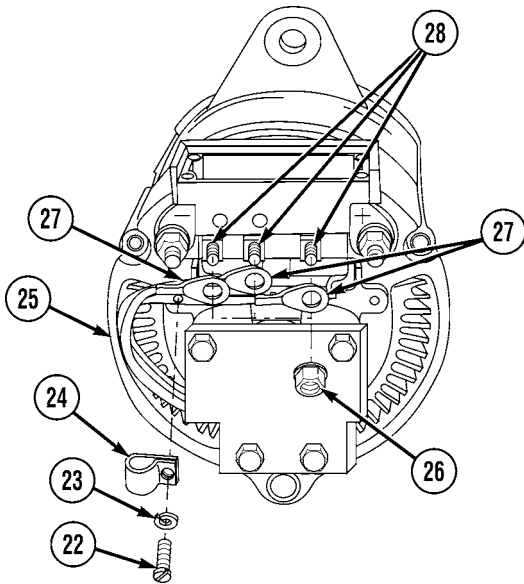
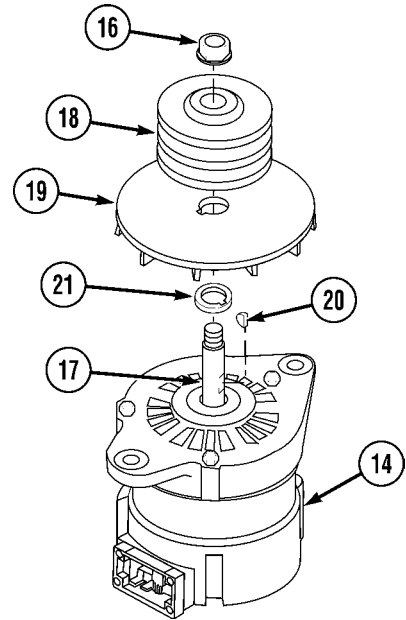

- (15) Remove two screws (29), lockwashers (30), screws (31), lockwashers (32), spacers (33), and capacitor (34) from slip ring end housing (25).

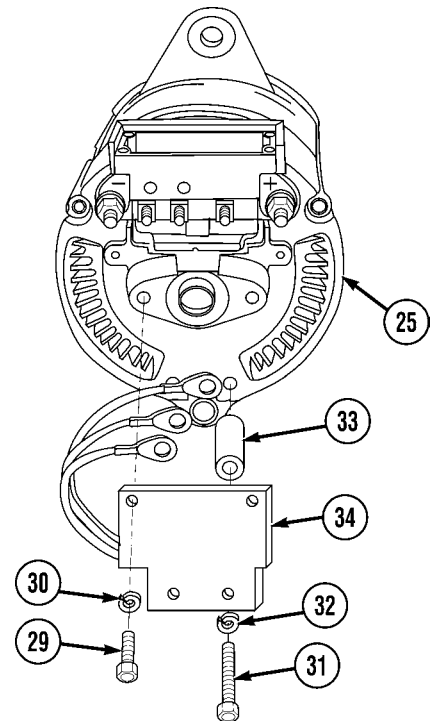

Electrical System Maintenance Instructions (Cont)

- (16) Remove three locknuts (35), washers (36), and screws (37) from drive end housing (38) and slip ring end housing (25).

CAUTION

When removing rotor, completely separate rotor from stator. Stator will still be attached to slip ring housing. Do not attempt to separate stator from slip ring housing. Failure to comply may result in damage to stator wires.

NOTE

Rotor will remain attached to drive end housing during removal.

- (17) Remove drive end housing (38) and rotor assembly (39) from slip ring end housing (25) and stator (40).
 (18) Remove three nuts (41) and stator (40) from slip ring end housing (25).
 (19) Remove two screws (42) and capacitor (43) from positive rectifier (44) and negative rectifier (45).

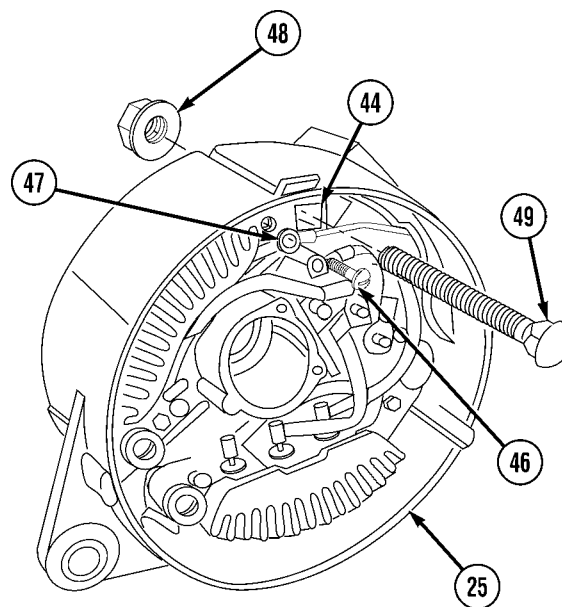
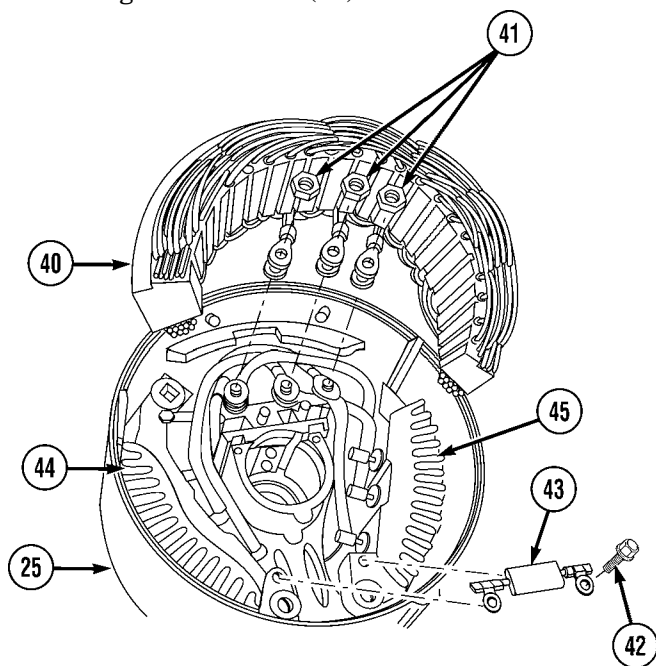
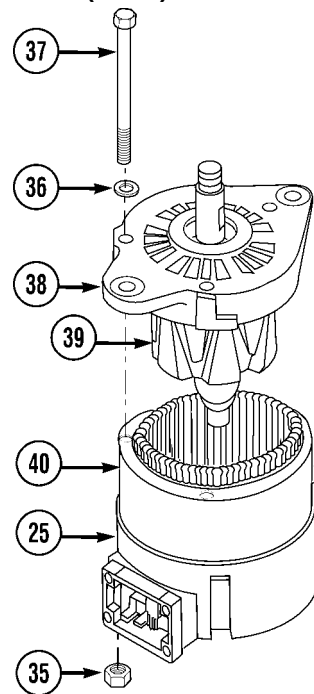

- (20) Remove screw (46) and wire (47) from positive rectifier (44).
 (21) Remove nut (48) and positive terminal screw (49) from positive rectifier (44) and slip ring end housing (25).

Electrical System Maintenance Instructions (Cont)

6-2.1. 24-VOLT ALTERNATOR REPAIR (CONT).

NOTE

Tag and mark wires before removal.

- (22) Remove six rectifier wires (50) from three terminals (28).

CAUTION

Do not remove lower bushing from positive rectifier. Failure to comply may damage bushing.

- (23) Remove lower mounting screw (51), lockwasher (52), washer (53), plastic washer (54), positive rectifier (44) with bushing (55), and bushing (56) from slip ring end housing (25).
- (24) Remove screw (57) and wire (58) from negative rectifier (45).

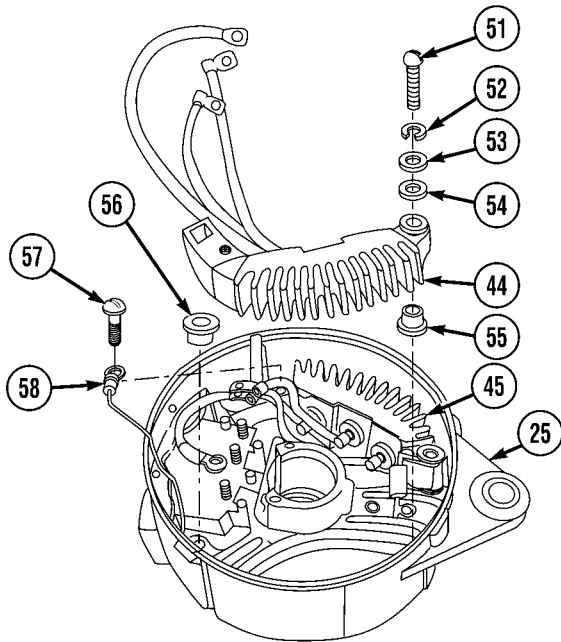
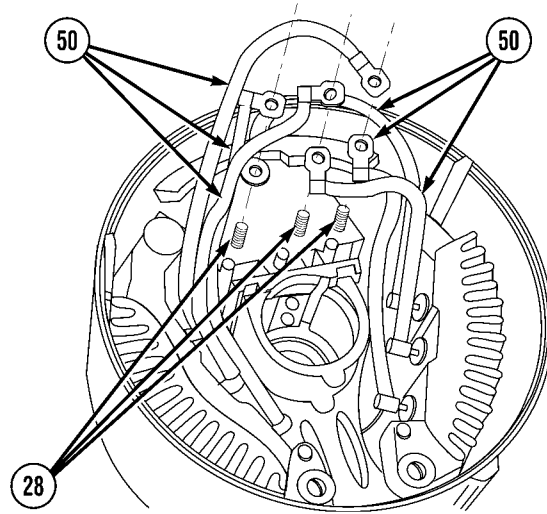

- (25) Remove nut (59), negative terminal screw (60), two insulation bushings (61), regulator holder (3), gasket (62), wire (47), and wire (58) from negative rectifier (45) and slip ring end housing (25).
- (26) Remove three nuts (63) and terminal studs (64) from regulator holder (3).

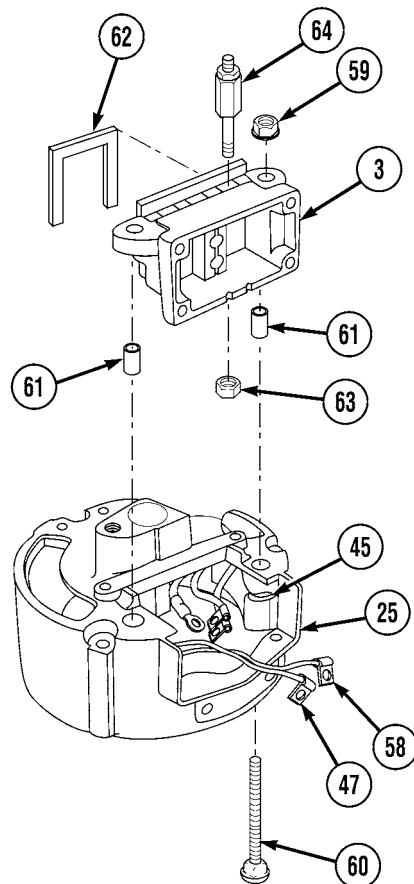

Electrical System Maintenance Instructions (Cont)

CAUTION

Do not remove lower bushing from negative rectifier. Failure to comply may damage bushing.

- (27) Remove lower mounting screw (65), lockwasher (66), washer (67), plastic washer (68), negative rectifier (45) with bushing (69), and two washers (70) from slip ring end housing (25).

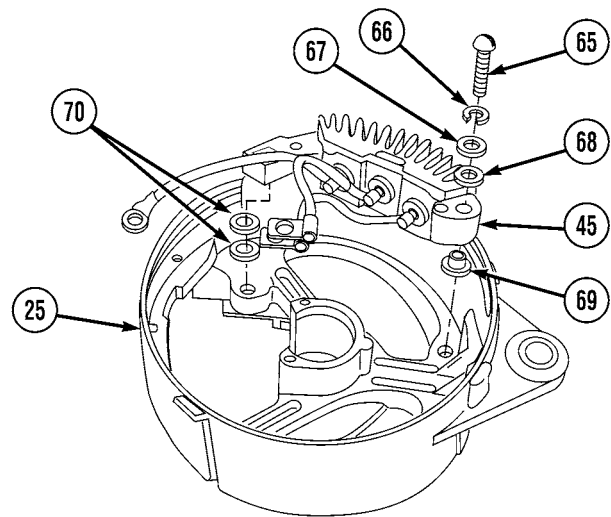

- (28) Position slip ring end housing (25) in press and remove bearing (71).
 (29) Remove bushing (72) from slip ring end housing (25).

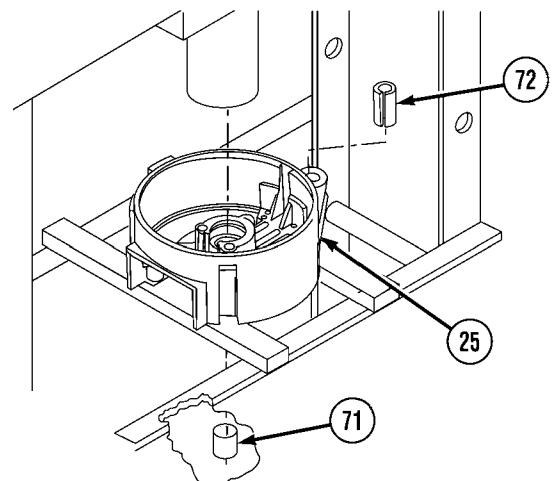

- (30) Position drive end housing (38) and rotor assembly (39) in press with threaded end of shaft (17) pointing upward.

CAUTION

Protect rotor assembly from striking floor while pressing from drive end housing. Failure to comply may result in damage to rotor assembly.

- (31) Press rotor assembly (39) out from drive end housing (38).

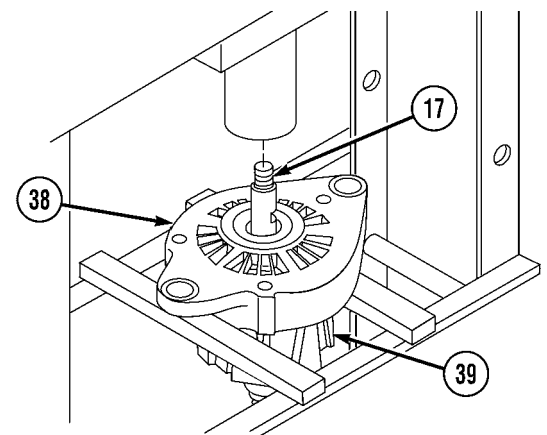

Electrical System Maintenance Instructions (Cont)

6-2.1. 24-VOLT ALTERNATOR REPAIR (CONT).

- (32) Remove four screws (73) and bearing retainer (74) from drive end housing (38).

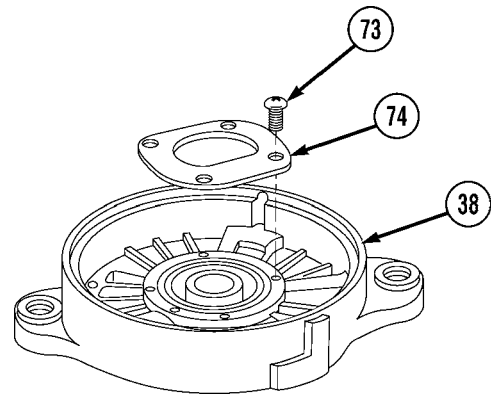

- (33) Position drive end housing (38) in press with bearing (75) side down.
- (34) Press bearing (75) out of drive end housing (38).

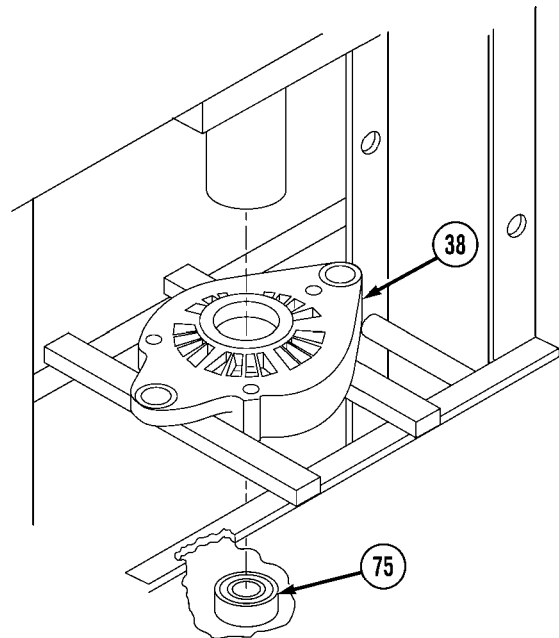

b. Testing.

- (1) Touch negative (-) test lead of multimeter to bare metal surface on positive rectifier (1).

NOTE

If multimeter does not indicate low resistance in step (2), positive rectifier is defective. Replace rectifier.

- (2) Touch positive (+) test lead of multimeter separately to each of three eyelet terminals (2).

- (3) Touch positive (+) test lead to bare metal surface on positive rectifier (1).

NOTE

If multimeter does not indicate infinity in step (4), positive rectifier is defective. Replace rectifier.

- (4) Touch negative (-) test lead separately to each of three eyelet terminals (2).

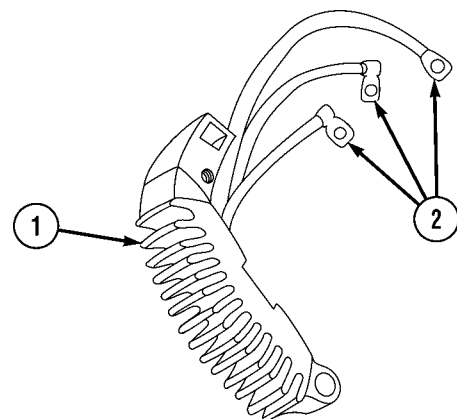

Electrical System Maintenance Instructions (Cont)

- (5) Touch negative (-) test lead to bare metal surface on negative rectifier (3).

NOTE

If multimeter does not indicate infinity in step (6), positive rectifier is defective. Replace rectifier.

- (6) Touch positive (+) test lead separately to each of three eyelet terminals (2).
- (7) Touch positive (+) test lead to bare metal surface on negative rectifier (3).

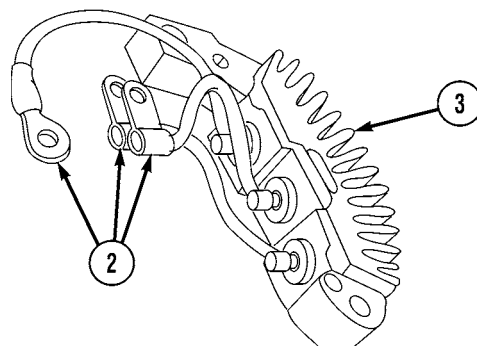

NOTE

If multimeter does not indicate low resistance in step (8), positive rectifier is defective. Replace rectifier.

- (8) Touch negative (-) test lead separately to each of three eyelet terminals (2).

NOTE

If resistance reading in step (9) is low, stator is grounded and requires replacement.

- (9) Touch one test lead to bare metal surface of stator (4) and other test lead separately to each pair of three stator ring terminals (5, 6, and 7).

NOTE

If resistance is not 1.0 ohm or less, stator is defective. Replace stator.

- (10) Touch test leads to pairs of stator ring terminals (5 and 6), (6 and 7), and (5 and 7), and read resistance across each set of terminals.

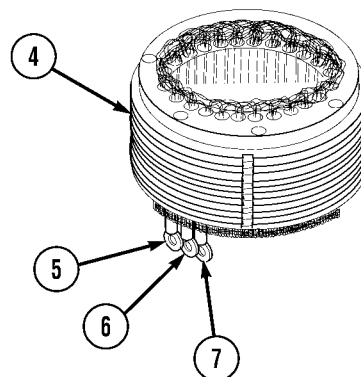

Electrical System Maintenance Instructions (Cont)

6-2.1. 24-VOLT ALTERNATOR REPAIR (CONT).

NOTE

If multimeter does not indicate an open circuit in either test, rotor coil is grounded. Replace rotor.

- (11) Touch one test lead to bare metal surface on shaft (8) and other test lead separately to each slip ring (9).

NOTE

If resistance is not 10.0 ohms or less, replace rotor.

- (12) Touch test leads to each slip ring (9).

NOTE

Minimum outside diameter (OD) of slip rings is 1.057 in. (26.85 mm). If measurement is less, replace rotor.

- (13) Measure outside diameter (OD) of slip rings (9).

NOTE

Minimum outside diameter (OD) of shaft is 0.669 in. (17 mm). If measurement is less, replace rotor.

- (14) Measure diameter of shaft (8).

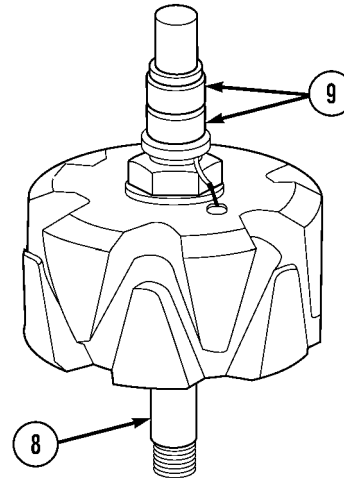

c. Cleaning/Inspection.

WARNING

- Dry cleaning solvent P-D-680 is toxic and flammable. Wear protective goggles and gloves and use only in well-ventilated area. Avoid contact with skin, eyes, and clothing, and do not breathe vapors. DO NOT use near open flame or excessive heat. The flash point is 100-138°F (38-59°C). If you become dizzy while using cleaning solvent, get fresh air immediately and medical aid. If contact with eyes is made, wash your eyes with water and get medical aid immediately.
- Compressed air for cleaning purposes will not exceed 30 psi (207 kPa). Use only with effective chip guarding and personal protective equipment (goggles/shield, gloves, etc.).

CAUTION

Do not soak stator or rotor in solvents. Damage to insulation may result.

- (1) Clean stator and rotor with dry cleaning solvent and clean cloth.

Electrical System Maintenance Instructions (Cont)

- (2) Dry stator and rotor with compressed air or dry cloth.
- (3) Clean all other components, except bearings, in dry cleaning solvent.
- (4) Inspect electrical assemblies for damage, frayed or bare wires, or loose connections.
- (5) Inspect mechanical assemblies for damage. Check for old or excess grease.
- (6) Clean rectifier assembly holes and terminal screws to ensure good electrical contact.
- (7) Clean carbon coating off slip rings with crocus cloth
- (8) Inspect brushes for burnt appearance, cracks, broken edges.
- (9) Check brush wear and replace if length measures less than 0.19 in. (4.8 mm).
- (10) Check drive end housing bearing for smooth rotation. If bearing binds, replace bearing.
- (11) Check slip ring housing bearing for missing rollers. If rollers are missing, replace bearing.

d. Assembly.

- (1) Position drive end housing (1) in press.

CAUTION

Apply pressure only on outer portion of race when pressing bearing into drive end housing. Failure to comply may result in equipment damage.

- (2) Press bearing (2) in drive end housing (1).
- (3) Install bearing retainer (3) in drive end housing (1) with four screws (4).

NOTE

Threaded end of shaft must point downward.

- (4) Install rotor assembly (5) in drive end housing (1).
- (5) Remove rotor assembly (5) from press.

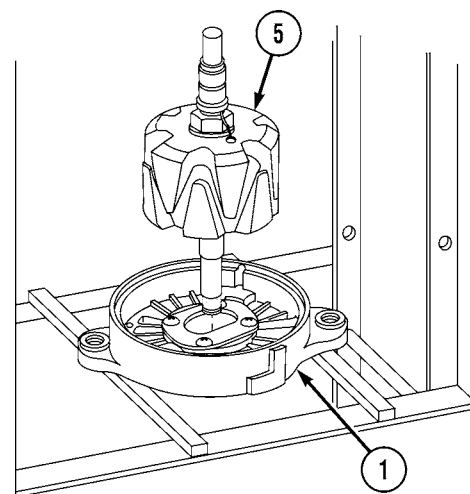
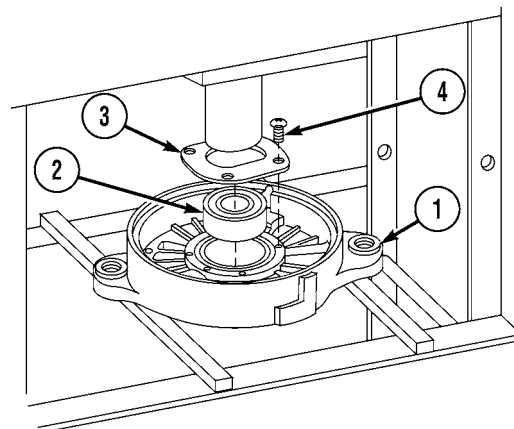

Electrical System Maintenance Instructions (Cont)

6-2.1. 24-VOLT ALTERNATOR REPAIR (CONT).

- (6) Position slip ring end housing (6) in press.

NOTE

When properly installed, bearing seats on lip inside bearing bore.

- (7) Press bearing (7) in slip ring end housing (6).
- (8) Press bushing (8) in slip ring end housing (6).
- (9) Remove slip ring end housing (6) from press.
- (10) Coat bearing (7) rollers with grease.

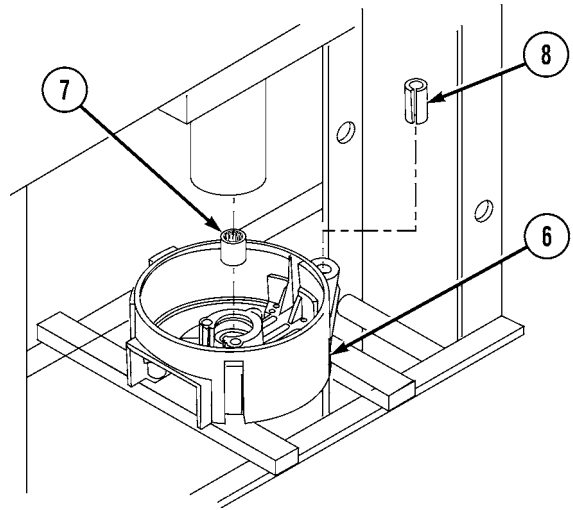

- (11) Install negative (-) rectifier (9) in slip ring end housing (6) with bushing (10), two washers (11), plastic washer (12), washer (13), lockwasher (14), and mounting screw (15).
- (12) Install black wire (16) on negative (-) rectifier (9) with screw (17).
- (13) Install positive (+) rectifier (18) in slip ring end housing (6) with bushing (19), bushing (20), plastic washer (21), washer (22), lockwasher (23), and mounting screw (24).

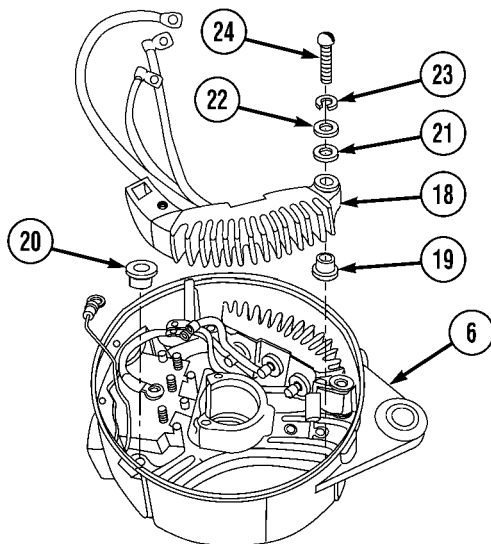
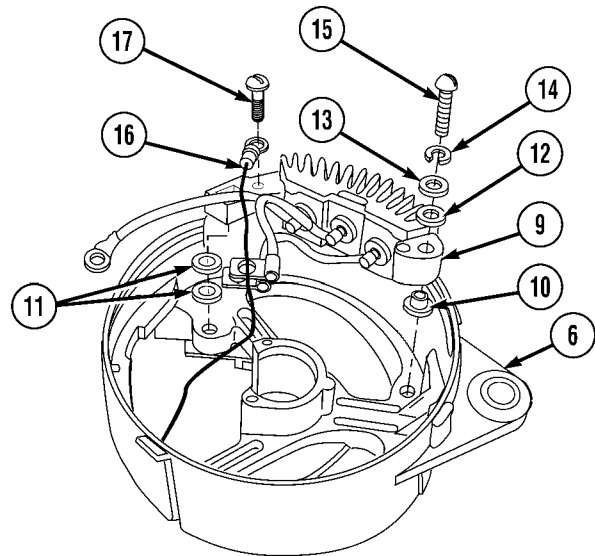

Electrical System Maintenance Instructions (Cont)

(14) Install red wire (25) on positive (+) rectifier (18) with screw (26).

(15) Install three terminal studs (27) on regulator holder (28) with three nuts (29).

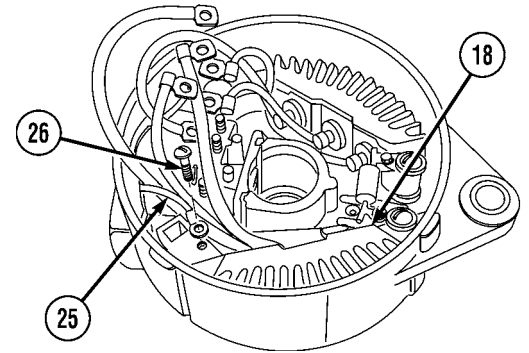

CAUTION

Red and black rectifier wires should be positioned in grooves between regulator holder and slip ring end housing. Failure to comply may result in damaged wiring.

(16) Install positive (+) terminal screw (30), negative (-) terminal screw (31), two insulation bushings (32), regulator holder (28), new gasket (33), and two nuts (34) in slip ring end housing (6), positive (+) rectifier (18), and negative (-) rectifier (9).

NOTE

- Rectifier leads should be firmly seated in regulator holder.
- Wires should be positioned in locations marked during removal.

(17) Install six rectifier leads (35) on three regulator studs (36).

(18) Install capacitor (37) on positive rectifier (18) and negative rectifier (9) with two screws (38).

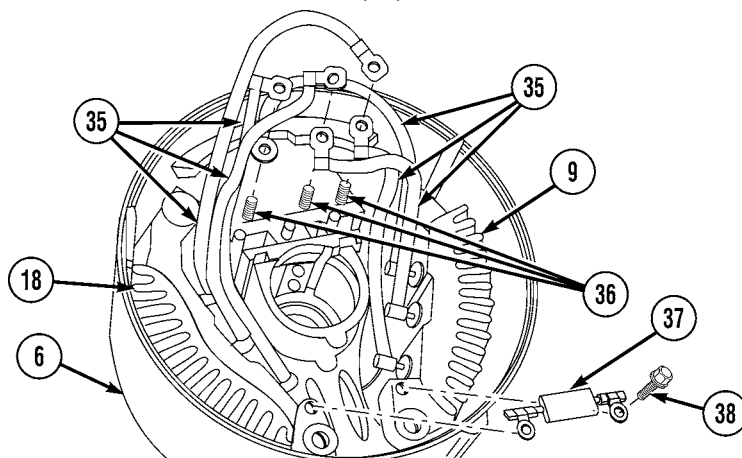
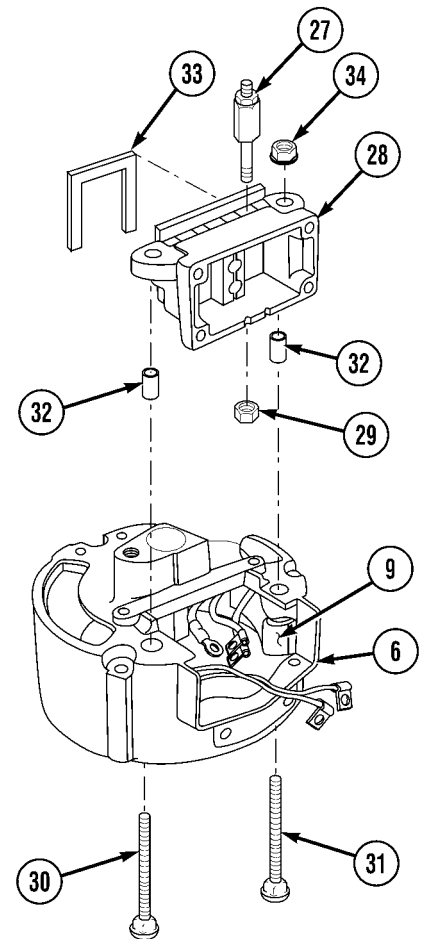

Electrical System Maintenance Instructions (Cont)

6-2.1. 24-VOLT ALTERNATOR REPAIR (CONT).

- (19) Install stator ring terminals (39) on slip ring end housing (6) and regulator studs (36) with three nuts (40).

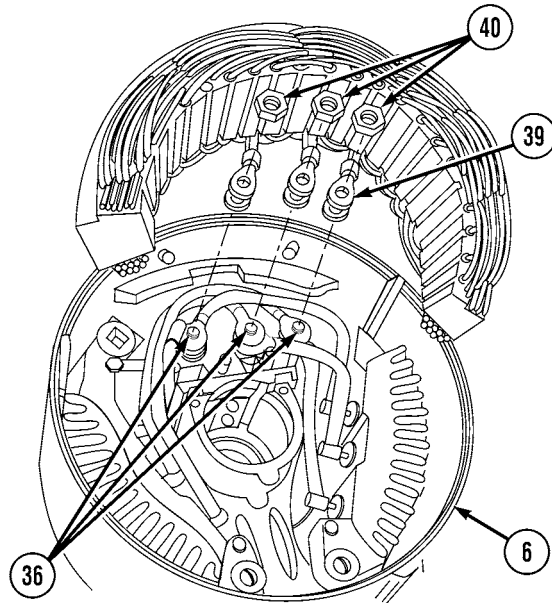

- (20) Aline screw holes on slip ring end housing (6), stator (41), and drive end housing (1).
- (21) Install slip ring end housing (6) on drive end housing (1) with three screws (42), washers (43), and locknuts (44).

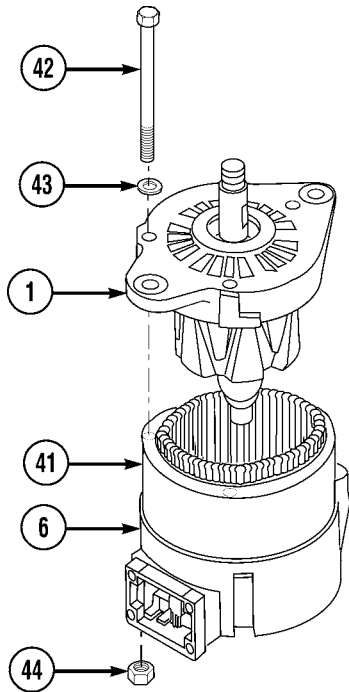

- (22) Install capacitor (45) on slip ring end housing (6) with two screws (46), lockwashers (47), screws (48), lockwashers (49), and spacers (50).

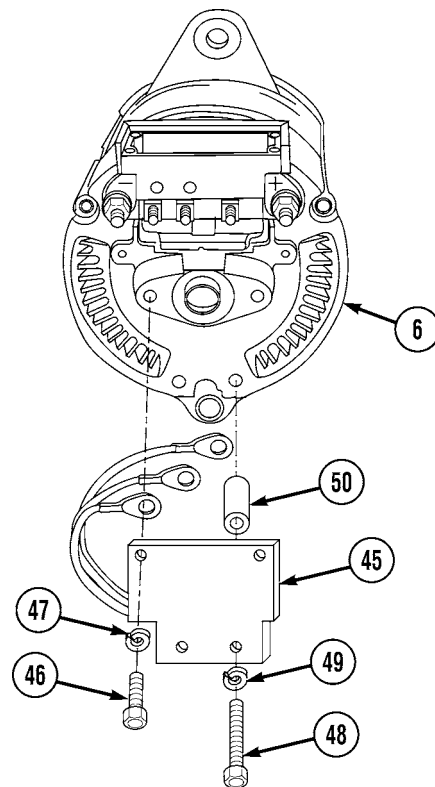

Electrical System Maintenance Instructions (Cont)

NOTE

Capacitor wires have three different lengths. Wires should be routed accordingly.

- (23) Install three wires (51) on regulator studs (36) with nuts (52).
- (24) Secure three wires (51) to slip ring end housing (6) with screw (53), lockwasher (54), and clip (55).

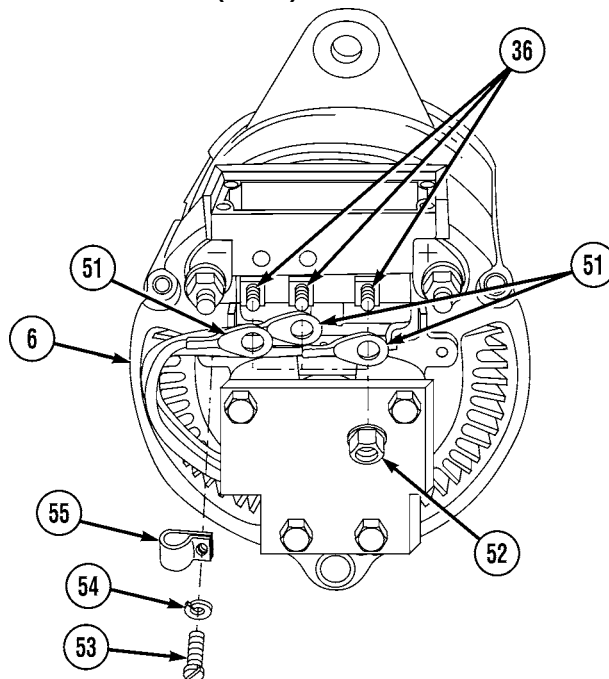

- (25) Position spacer (56), key (57), cooling plate (58), pulley (59), and locknut (60) on shaft (61). Do not tighten.

NOTE

Vise is used to hold pulley securely for step (26).

- (26) Position alternator (62) in vise.
- (27) Tighten locknut (60) to 70-80 lb-ft (95-108 N·m).
- (28) Remove alternator (62) from vise.

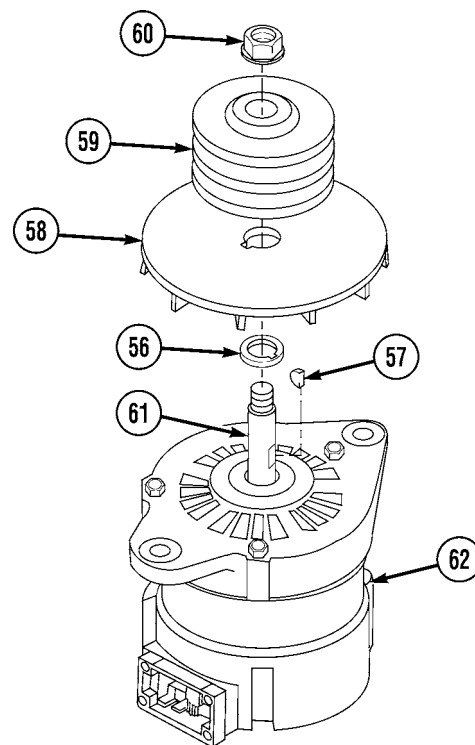

Electrical System Maintenance Instructions (Cont)

6-2.1. 24-VOLT ALTERNATOR REPAIR (CONT).

NOTE

If using original brushes, wear pattern must match radius of slip rings.

- (29) Insert two brushes (63) into regulator holder (28).

NOTE

Brush springs are held compressed with 1/16 in. sockethead screw key to aid installation of voltage regulator.

- (30) Compress brush springs (63). Install 1/16 in. sockethead screw key through pilot hole (64) in regulator holder (28), over springs (63), and into pilot hole (65) inside regulator holder (28).

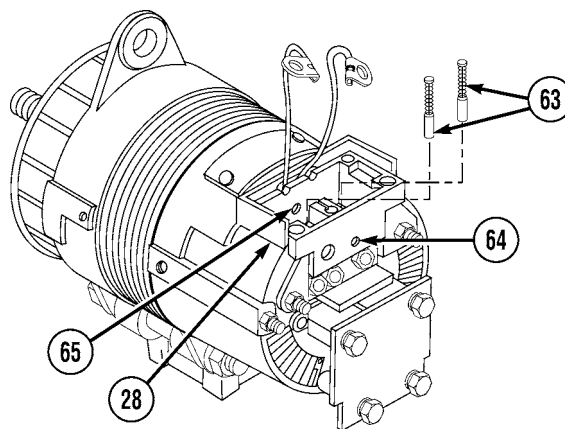

CAUTION

Regulator can only be installed one way. Position regulator so regulator pins align with brush openings. Failure to comply may result in damage to equipment.

NOTE

Regulator must be positioned close to housing to allow installation of wires.

- (31) Install red wire (25) on positive (+) terminal of voltage regulator (66) with lockwasher (67) and nut (68).
- (32) Install black wire (16) on negative (-) terminal of voltage regulator (66) with lockwasher (69) and nut (70).
- (33) Install blue wire (71) and ignition (IGN) stud (72) in regulator holder (28).
- (34) Install nut (73) on ignition (IGN) stud (72).

CAUTION

Brush retaining pin must be positioned in grooves between regulator holder and slip ring end housing. Failure to comply may result in damaged wiring.

- (35) Position gasket (74) and voltage regulator (66) on regulator holder (28) with four screws (75). Do not tighten.
- (36) Remove sockethead screw key from rear of regulator holder (28).
- (37) Tighten four screws (75) on voltage regulator (66).

e. Follow-On Maintenance.

Install alternator (TM 9-2320-360-20).

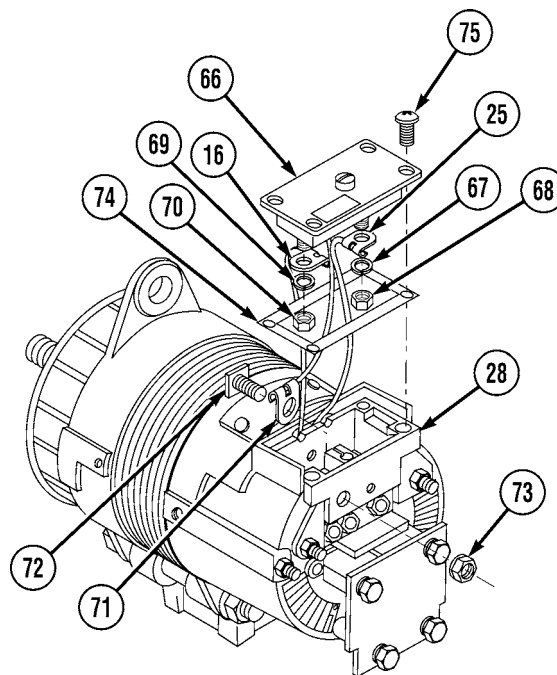

END OF TASK

Electrical System Maintenance Instructions (Cont)

6-3. STARTER SOLENOID REMOVAL/INSTALLATION.

This task covers:

- a. Removal
- b. Installation
- c. Follow-on Maintenance

INITIAL SETUP

Models
All

References
None

Test Equipment
None

Equipment Condition
TM or Para *Condition Description*
TM 9-2320-279-20 Starter removed.

Special Tools
None

Special Environmental Conditions
None

Supplies
Sealant, RTV200 Electrical, Item 55.2,
Appendix C

General Safety Instructions
None

Personnel Required
MOS 63G, Fuel and electrical systems repairer

Level of Maintenance
Direct Support

a. Removal.

- (1) Remove nut (1) and lockwasher (2).
- (2) Disconnect ground lead (3) from terminal (4).

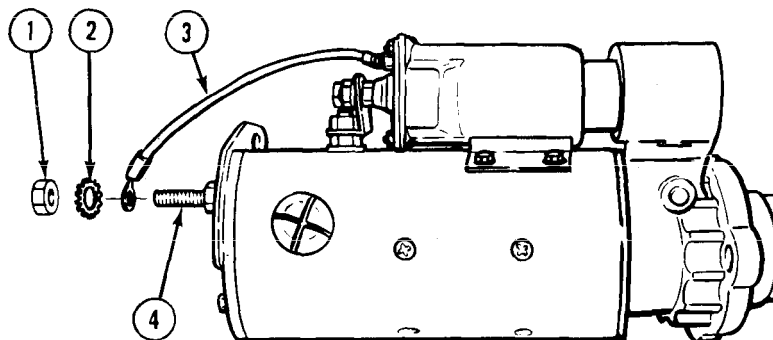

- (3) Remove nut (5) from motor terminal (6).
- (4) Remove nut (7) from field terminal (8).

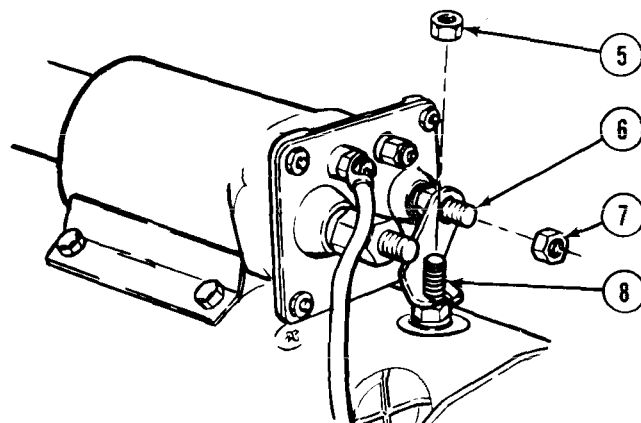

6-3. STARTER SOLENOID REMOVAL/INSTALLATION (CONT).

- (5) Remove nut (9) and ground lead (3).
- (6) Remove four screws (10) from solenoid (11) and starter (12).

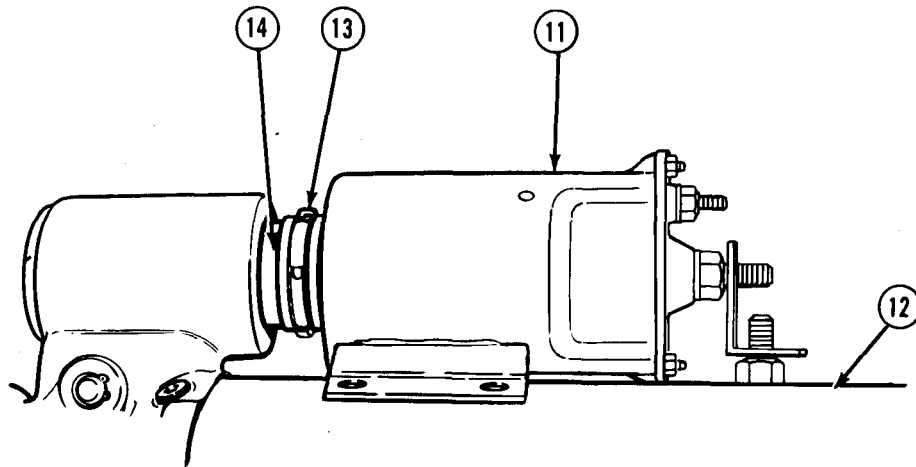
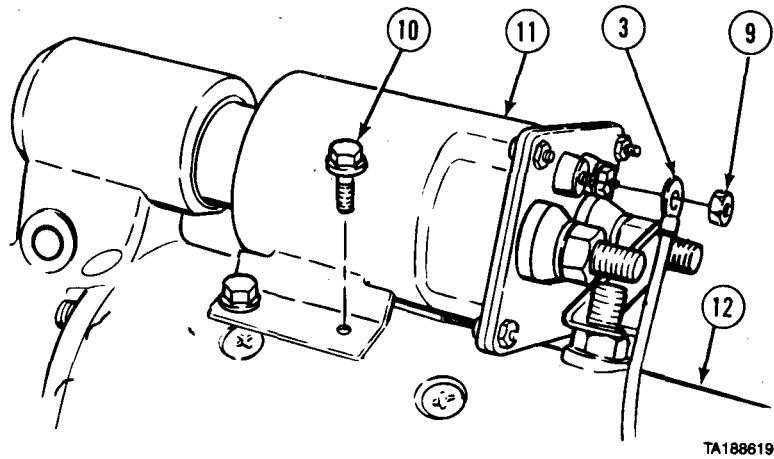

- (7) Loosen clip (13).
- (8) Remove solenoid (11) and clip (13) from plunger (14) and starter (12).

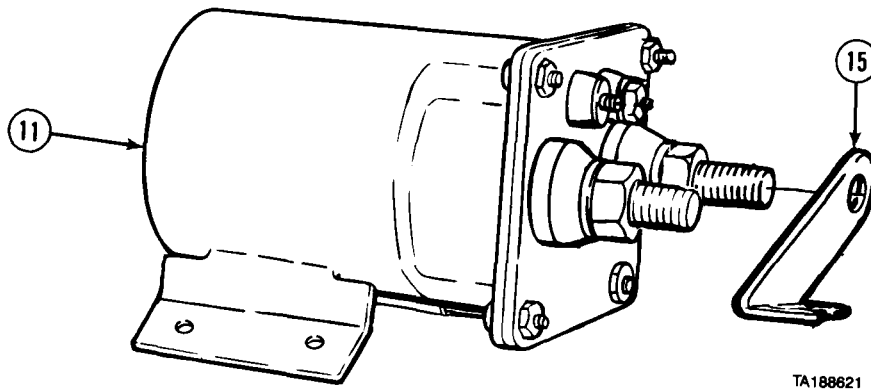

- (9) Remove connector (15) from solenoid (11).

Electrical System Maintenance Instructions (Cont)

b. Installation.

WARNING

Adhesives, solvents, and sealing compounds can burn easily, can give off harmful vapors, and are harmful to skin and clothing. To avoid injury or death, keep away from open fire and use in well-ventilated area. If adhesive, solvent, or sealing compound gets on skin or clothing, wash immediately with soap and water.

NOTE

Apply electrical sealant to exposed wire connectors after installing connectors.

- (1) Install connector (1) on motor terminal (2).

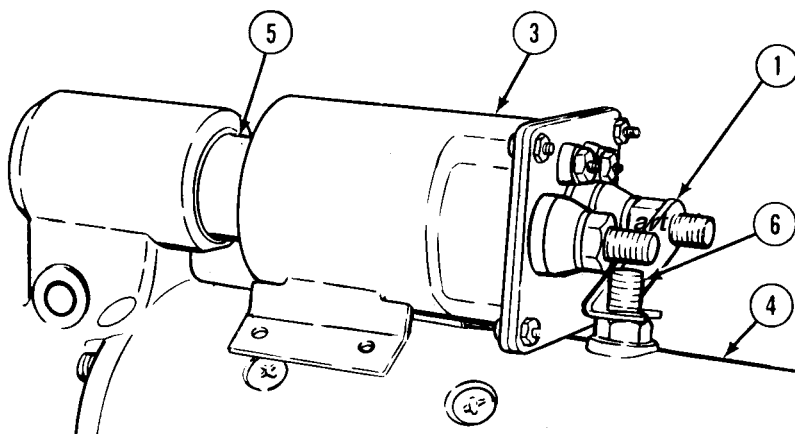
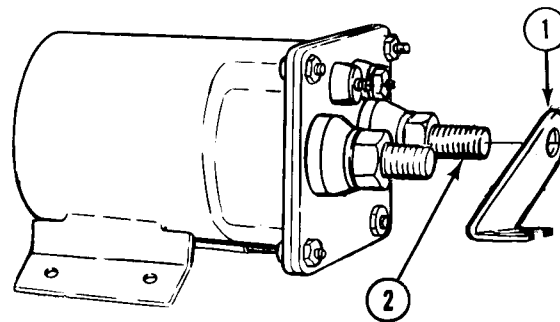

- (2) Position solenoid (3) on starter (4) and plunger (5).
- (3) Install connector (1) on field terminal (6).

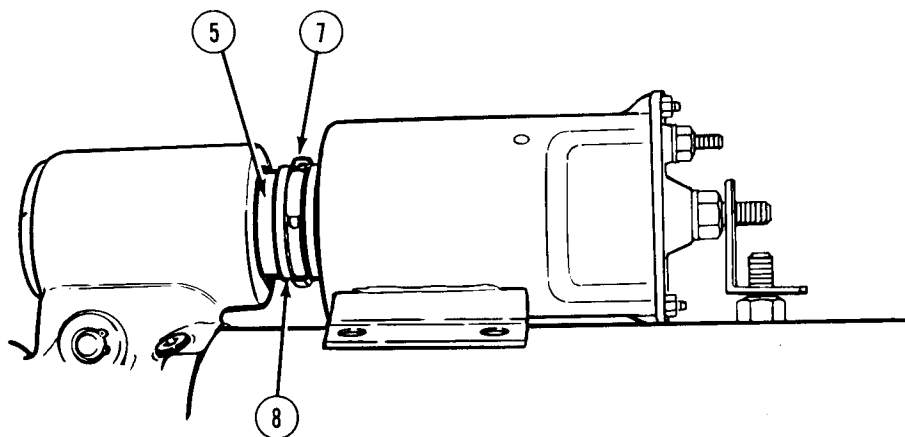

- (4) Install clip (7) over seal (8) on plunger (5).

6-3. STARTER SOLENOID REMOVAL/INSTALLATION (CONT).

- (5) Install four screws (9) into starter (4).
- (6) Install ground lead (10) and nut (11).

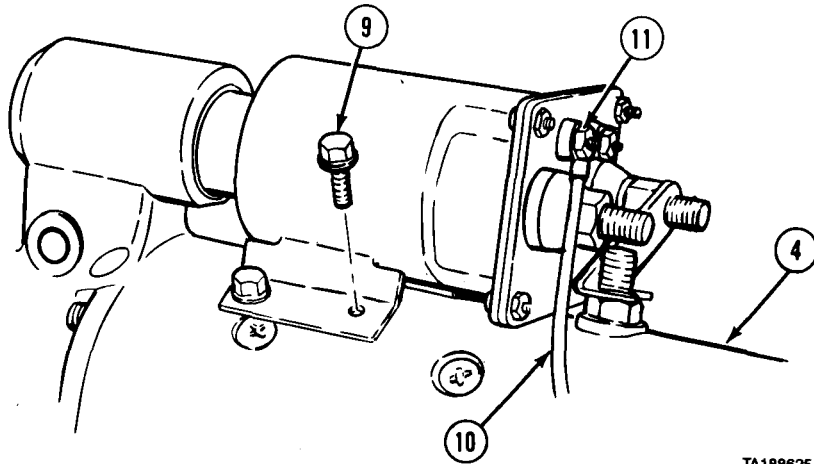

TA188625

- (7) Install nut (12) on motor terminal (2).
- (8) Install nut (13) on field terminal (6).

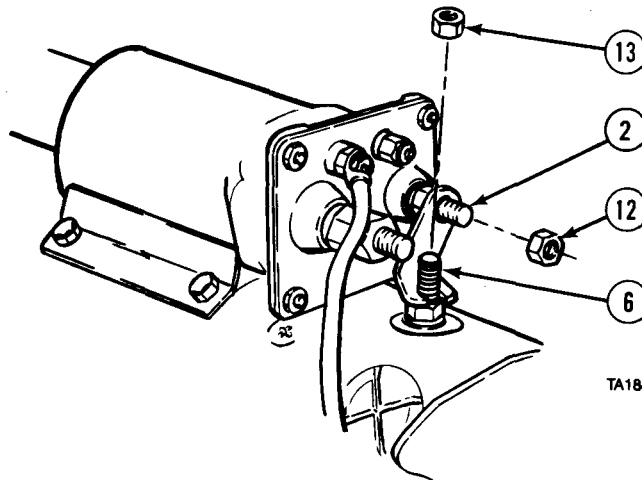

TA188626

- (9) Connect ground lead (10) to terminal (14) on starter (4) with lockwasher (15) and nut (16).

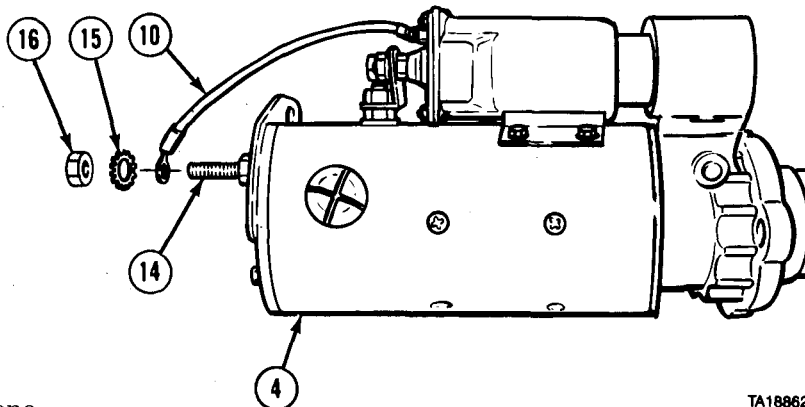

TA188627

c. Follow-on Maintenance. None.

END OF TASK

Electrical System Maintenance Instructions (Cont)

6-4. STARTER MOTOR REPAIR AND TESTING.

This task covers:

- a. Disassembly
- b. Cleaning/Inspection
- c. Testing
- d. Assembly
- e. Follow-on Maintenance

INITIAL SETUP

Models

All

Test Equipment

None

Special Tools

None

Supplies

- Solvent, dry cleaning, Item 57, Appendix C
- Adhesive, epoxy, Item 2, Appendix C
- Oil, lubricating, Item 46, Appendix C
- Paper, abrasive, silicon carbide, 600 Grit, Item 52, Appendix C

Personnel Required

MOS 63G, Fuel and electrical systems repairer

References

None

Equipment Condition

TM or Para

Condition Description
Starter on clean work surface.

Special Environmental Conditions

None

General Safety Instructions

None

Level of Maintenance

Direct Support

a. Disassembly.

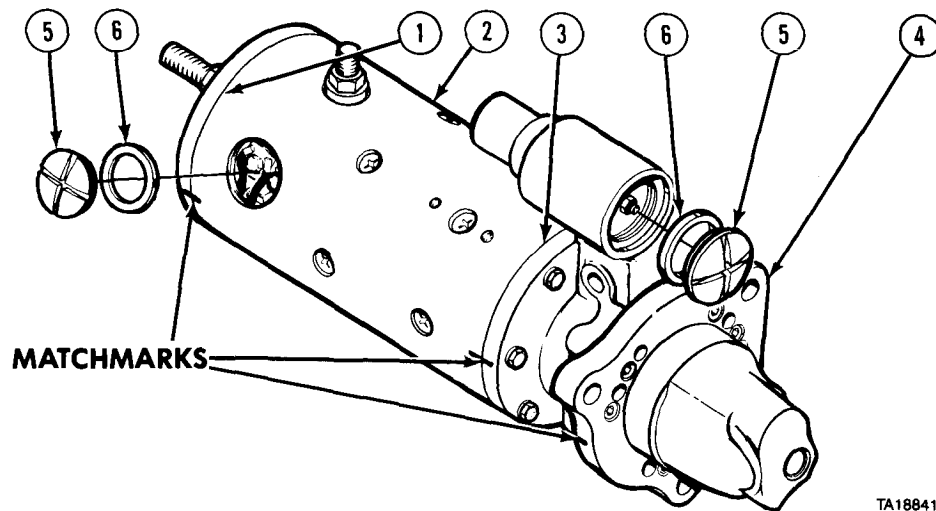

TA188411

- (1) Matchmark end cap (1), field frame (2), lever housing (3), and drive housing (4).
- (2) Remove inspection plug (5) and gasket (6) from field frame (2).
- (3) Remove inspection plug (5) and gasket (6) from lever housing (3).

6-4. STARTER MOTOR REPAIR AND TESTING (CONT.)

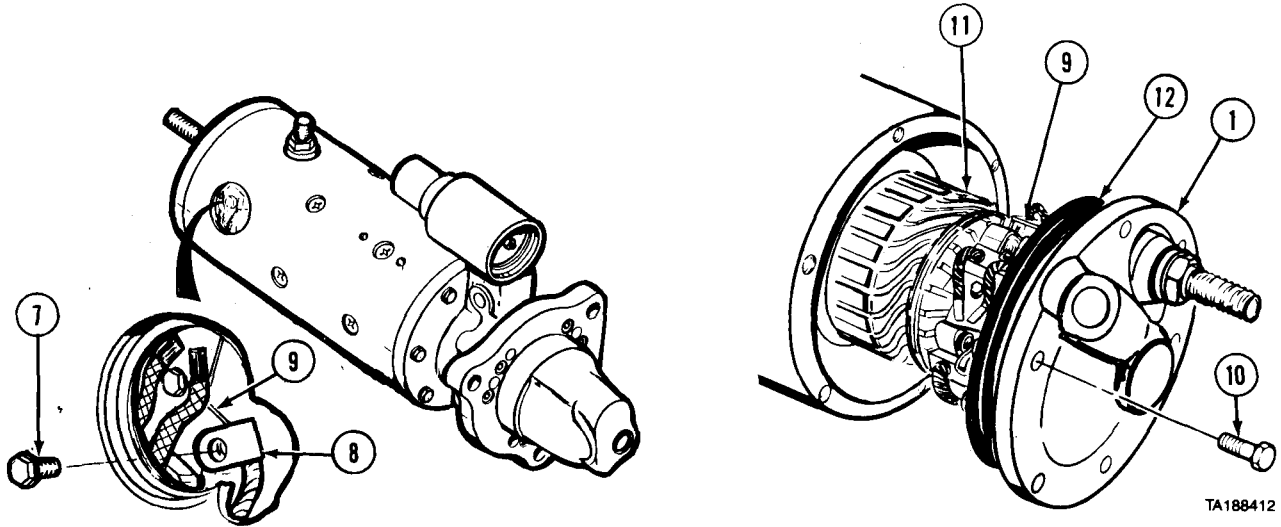

- (4) Remove three screws (7) to disconnect three field leads (8) from brush holder (9).
- (5) Remove six screws (10), end cap (1), and brush holder (9).

NOTE

Armature may stay with end cap or in field frame.

- (6) Remove armature (11).
- (7) Remove preformed packing (12) from end cap (1).
- (8) Remove washer (13) and thrust washer (14) from armature (11).

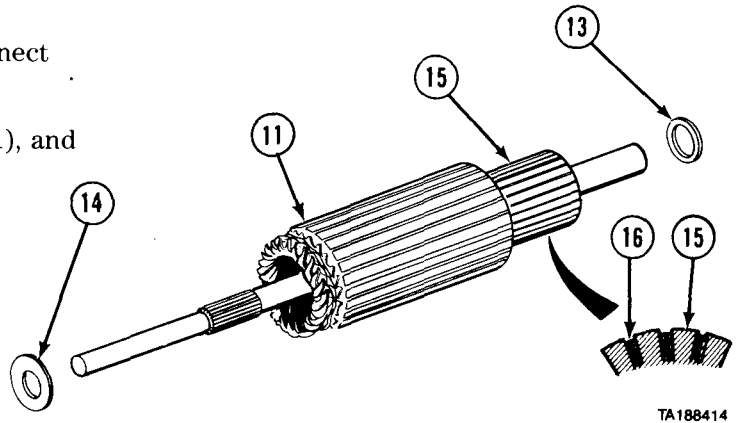

WARNING

Compressed air used for cleaning purposes will not exceed 30 psi (207 kPa). Use only with effective chip guarding and personal protective equipment, goggles, shield, and gloves.

- (9) Cut commutator (15) as required on lathe. When cutting commutator, cut no more than 0.005 in. (0.13 mm) at a time to remove scoring, pits, burrs, or to return commutator to round. Then make final cut of 0.002 in. (0.051 mm). Undercut mica (16) 1/32-in. (0.8 mm) deep and 1/32-in. (0.8 mm) wide. Blow off all loose copper and mica particles with compressed air.
- (10) Polish commutator (15) with abrasive paper.
- (11) Remove seven screws (17), lever housing (3), and drive housing (4).

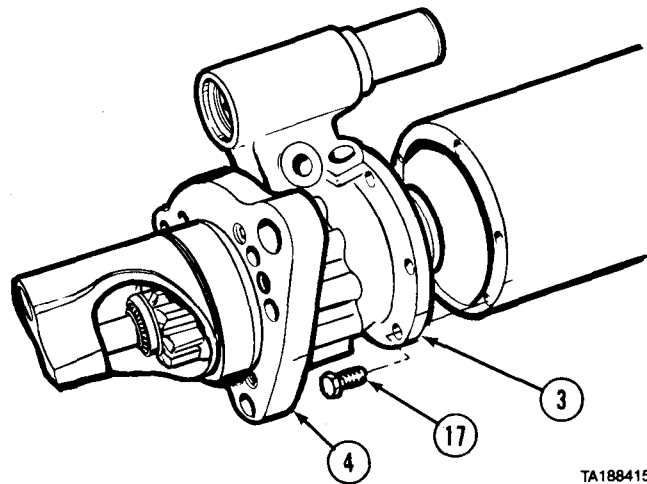

Electrical System Maintenance Instructions (Cont)

- (12) Remove five long screws (18), one short screw (19), and drive housing (4) from lever housing (3).
- (13) Remove starter drive (20) and preformed packing (21).
- (14) Remove retaining ring (22) and shift lever shaft (23) from lever housing (3).
- (15) Remove large preformed packing (24) and small preformed packing (25) from shift lever shaft (23).

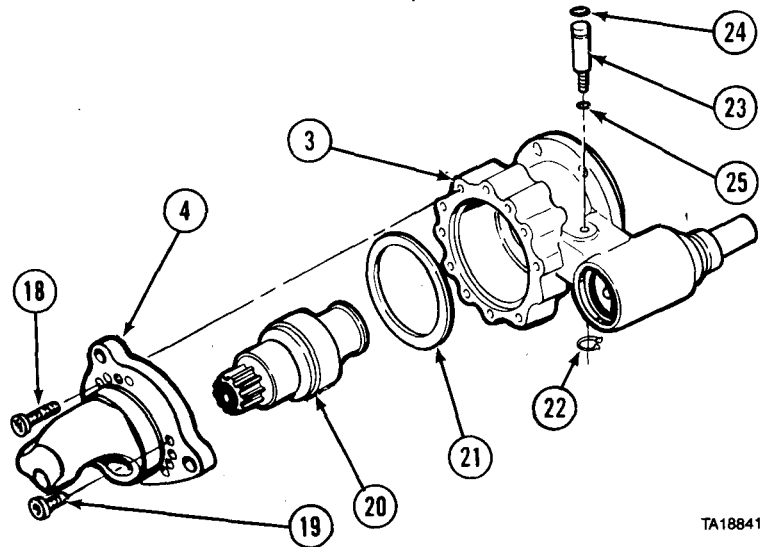

TA188416

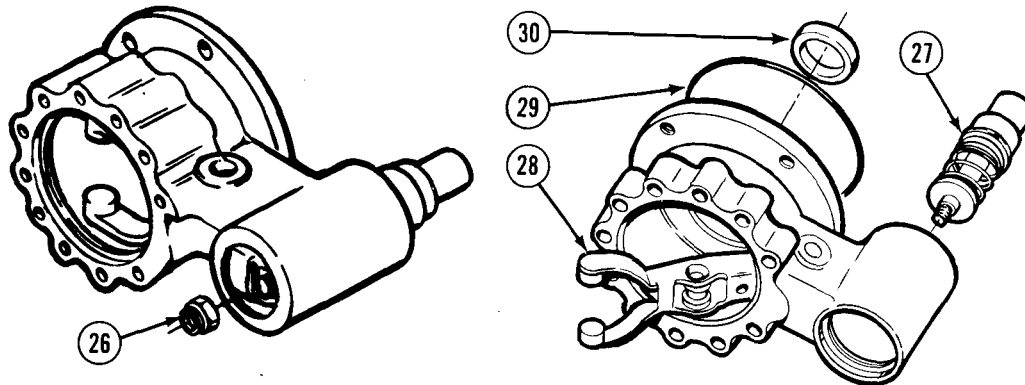

TA188417

- (16) Remove self-locking nut (26) and note number of turns.
- (17) Remove plunger (27) and shift lever (28).
- (18) Remove preformed packing (29) and oil seal (30).

- (19) Remove retaining ring (31) from plunger (27).
- (20) Remove retainer (32), spring (33), retainer (34), and boot (35) from plunger (27).
- (21) Remove washer (36) from boot (35).

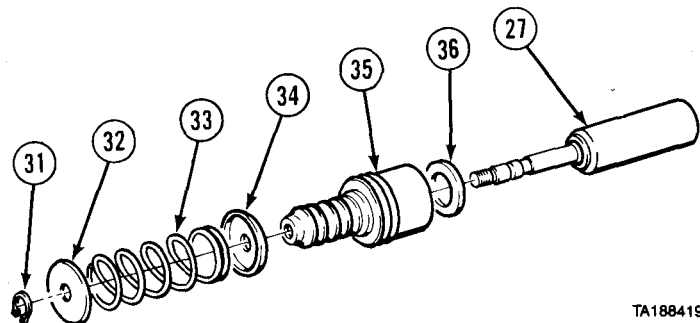

TA188419

Electrical System Maintenance Instructions (Cont)

6-4. STARTER MOTOR REPAIR AND TESTING (CONT).

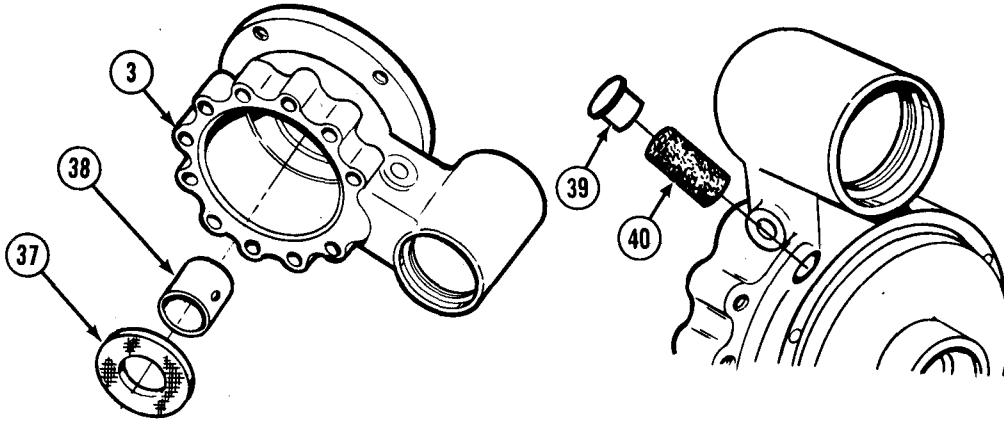

TA188420

- (22) Remove non-metallic washer (37).
- (23) Remove bushing (38) from lever housing (3).
- (24) Remove cup plug (39) and felt wick (40).

- (25) Remove cup plug (41) and felt wick (42) from drive housing (4).
- (26) Mark holes and remove six rubber balls (43).
- (27) Remove bushing (44).

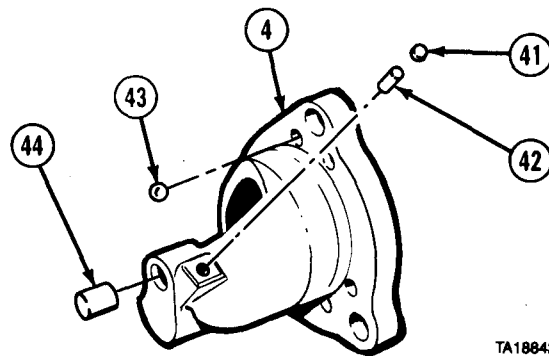

TA188422

- (28) Remove six screws (45) and brushes (46) from brush holder (9).

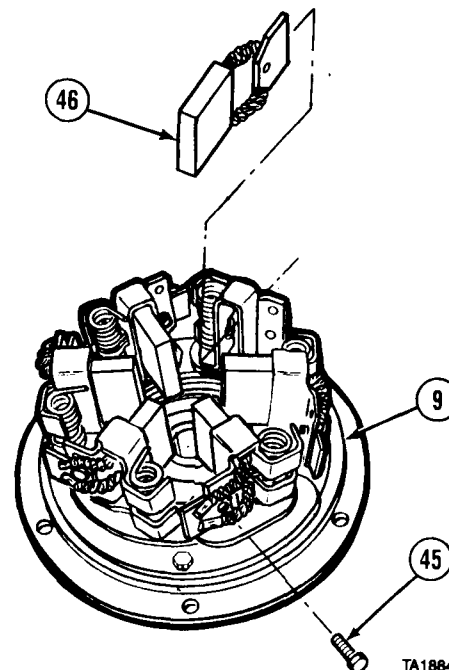

TA188423

Electrical System Maintenance Instructions (Cont)

- (29) Remove nut (47), lockwasher (48), and washer (49) from ground terminal (50).

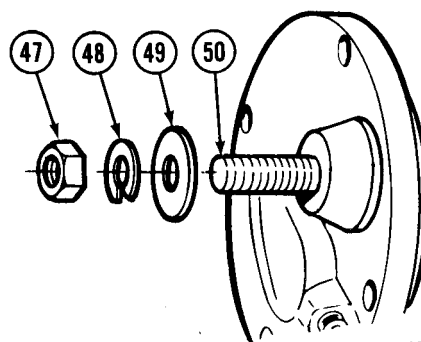

TA188424

- (30) Remove three screws (51) from brush holder (9) and end cap (1).

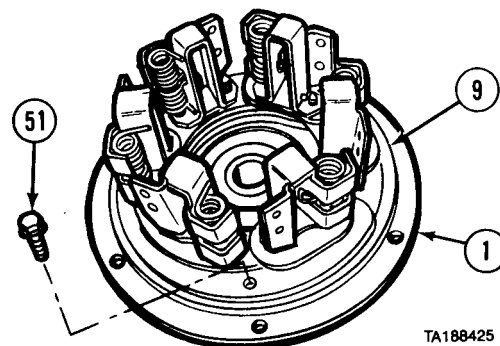

TA188425

- (31) Remove insulator (52) from end cap (1).
 (32) Remove end cap (1) from brush holder (9).
 (33) Remove rubber bushing (53), two insulating washers (54), and paper gasket (55) from ground terminal (50).

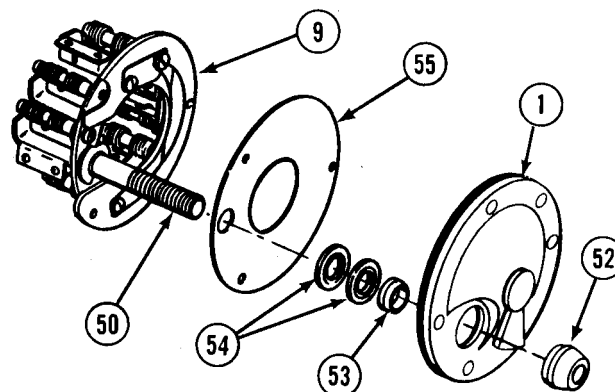

TA188426

- (34) Remove cup plug (56) and felt wick (57) from end cap (1).
 (35) Remove bushing (58) from end cap (1).

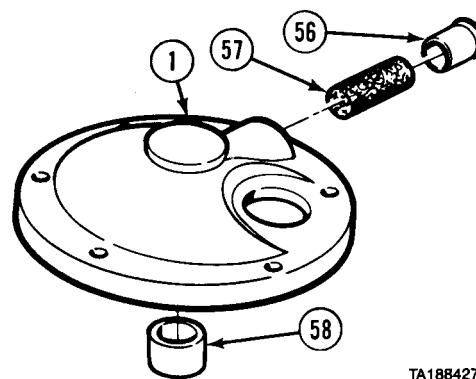

TA188427

6-4. STARTER MOTOR REPAIR AND TESTING (CONT).

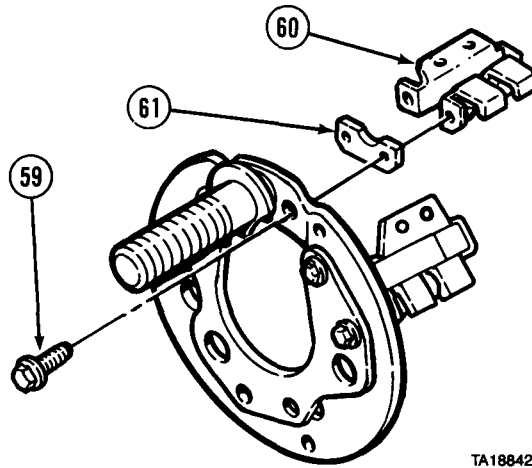

TA188429

(36) Remove six screws (59), three brush holders (60), and three plates (61).

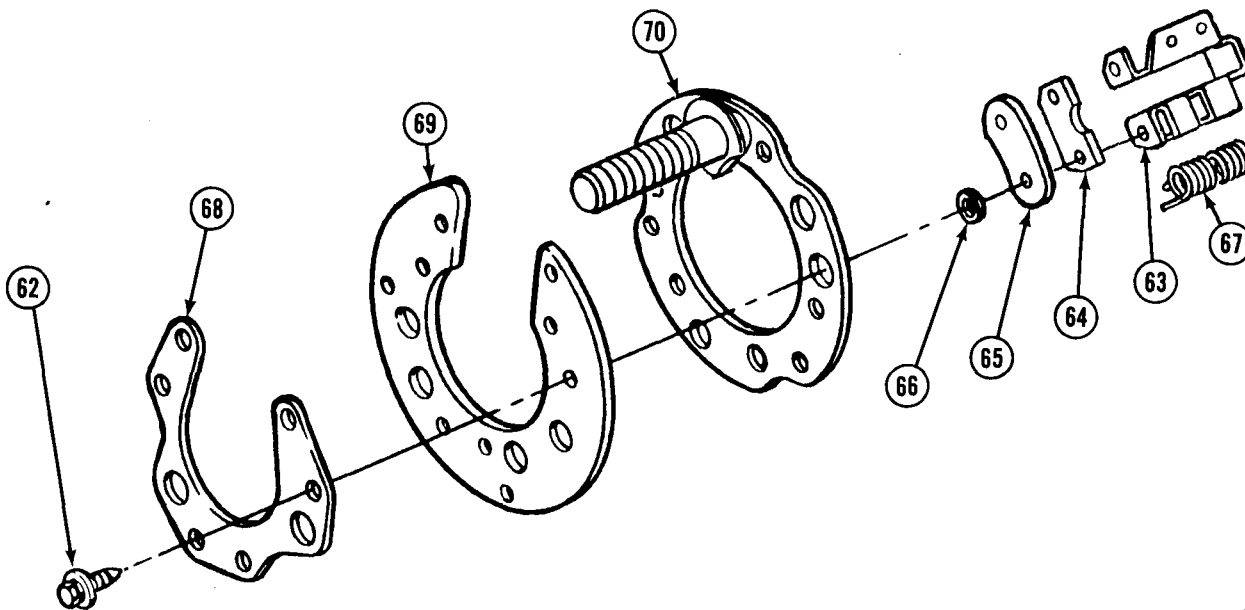

TA188430

(37) Remove six screws (62), three brush holders (63), three plates (64), three plate insulators (65), and six insulators (66).

(38) Remove six springs (67) from brush holders (63).

(39) Disassemble support plate (68), disc insulator (69), and plate assembly (70).

Electrical System Maintenance Instructions (Cont)

- (40) Remove nut (71), washer (72), and two insulators (73).
- (41) Remove 12 assembled screws (74).
- (42) Remove six pole shoes (75).

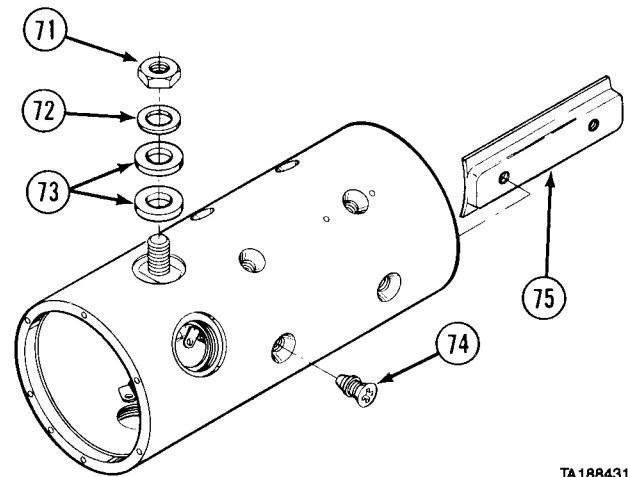

TA188431

- (43) Remove field coil (76) and plate insulator (77) from field frame (2).
- (44) Remove insulator bushing (78) from terminal stud (79).

b. Cleaning/Inspection.**WARNING**

Adhesives, solvents, and sealing compounds can burn easily, can give off harmful vapors, and are harmful to skin and clothing. To avoid injury or death, keep away from open fire and use in well-ventilated area. If adhesive, solvent, or sealing compound gets on skin or clothing, wash immediately with soap and water.

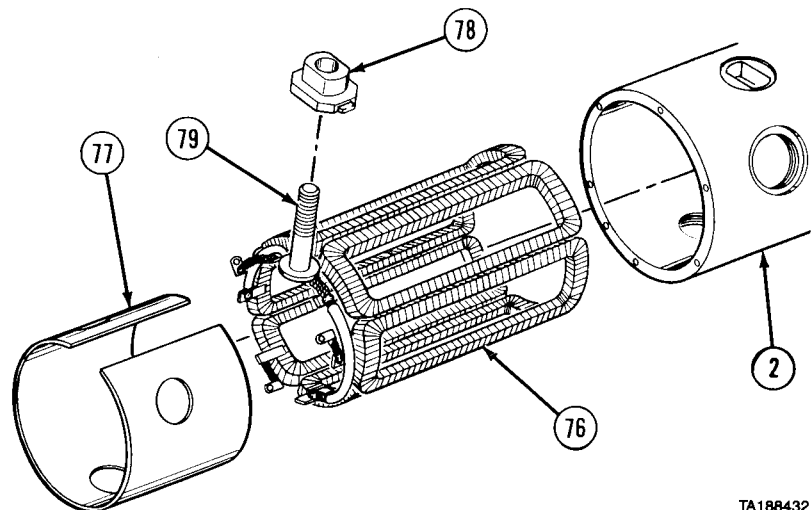

TA188432

- (1) Clean all metal parts in dry cleaning solvent except armature, field coil, and starter drive.
- (2) Clean starter drive with clean dry cloth.
- (3) Inspect field frame for cracks, breaks, or other obvious damage.
- (4) Inspect armature shaft for rough surfaces or damaged splines.
- (5) Inspect commutator contact surface for rough surface, pits, scoring, burns, hard carbon, oil coat, and out-of-round. Commutator diameter, when new, is approximately 2.3125 to 2.3250 in. (58.74 to 59.06 mm). Commutator diameter may not be less than 2.000 in. (50.8 mm) when returned to service. Commutator may not be more than 0.0020 in. (.051 mm) out-of-round.
- (6) Check length of brushes. If length is less than 0.50 in. (12.7 mm), replace brushes.
- (7) Inspect brush springs for distortion.
- (8) Inspect splines and gear teeth on starter drive for damage.
- (9) Check bushings for damage or wear. If inside diameter of bushings is more than 0.005-in. (0.127 mm) larger than shaft diameter, replace bushings.
- (10) Replace unserviceable parts.

6-4. STARTER MOTOR REPAIR AND TESTING (CONT).

c. Testing.

NOTE

Start testing with brush holder located directly over ground terminal.

- (1) Test brush holders (1, 2, and 3) one at a time. Place red (+) lead on ground terminal (4) and black (-) lead on each brush holder. Multimeter needle must move.
- (2) Test brush holders (5, 6, and 7) one at a time. Place red (+) lead on ground terminal (4) and black (-) lead on each brush holder. Multimeter needle must not move.

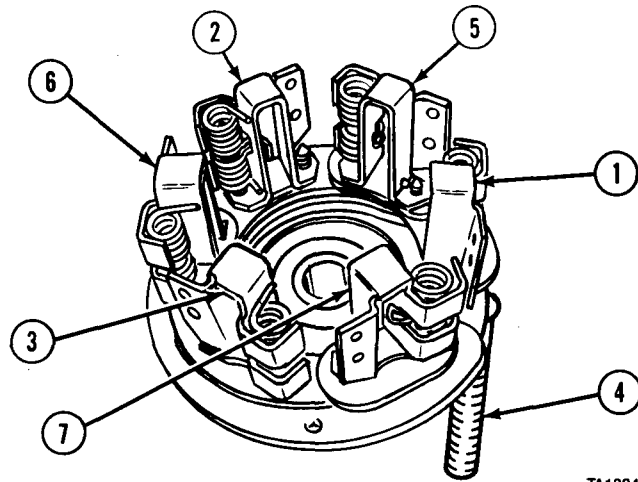

TA188433

- (3) Test armature (8). Place red (+) lead on end of shaft (9). Place black (-) lead on each metal strip (10) around large part of armature. Multimeter needle must move to zero.
- (4) Place red (+) lead on end of shaft (9). Place black (-) lead on each commutator strip (11). Multimeter needle must not move.

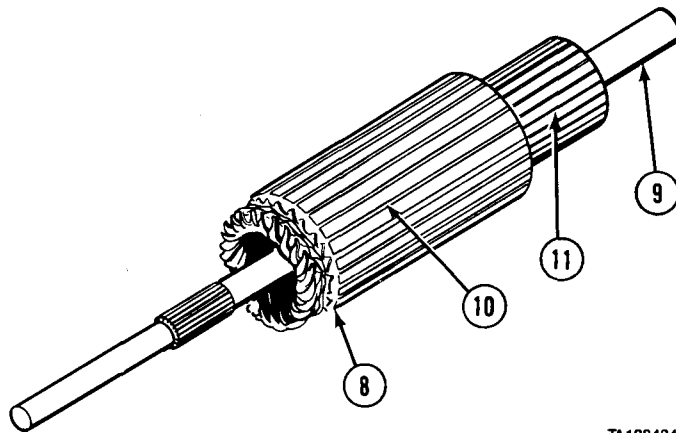

TA188434

- (5) Test field coil. Place red (+) lead on field terminal stud (12). Place black (-) lead on field frame (13). Multimeter needle must not move.
- (6) Place red (+) lead on field terminal stud (12). Place black (-) lead on one of field leads (14). Multimeter needle must move.
- (7) Move black (-) lead to other field leads (14). Multimeter needle must move.
- (8) Place red (+) lead on one field lead (14). Put black (-) lead on another field lead. Multimeter needle must move. Repeat for all leads.

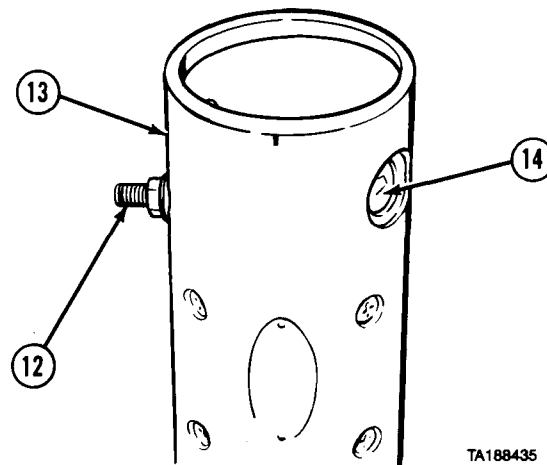

TA188435

Electrical System Maintenance Instructions (Cont)

d. Assembly.

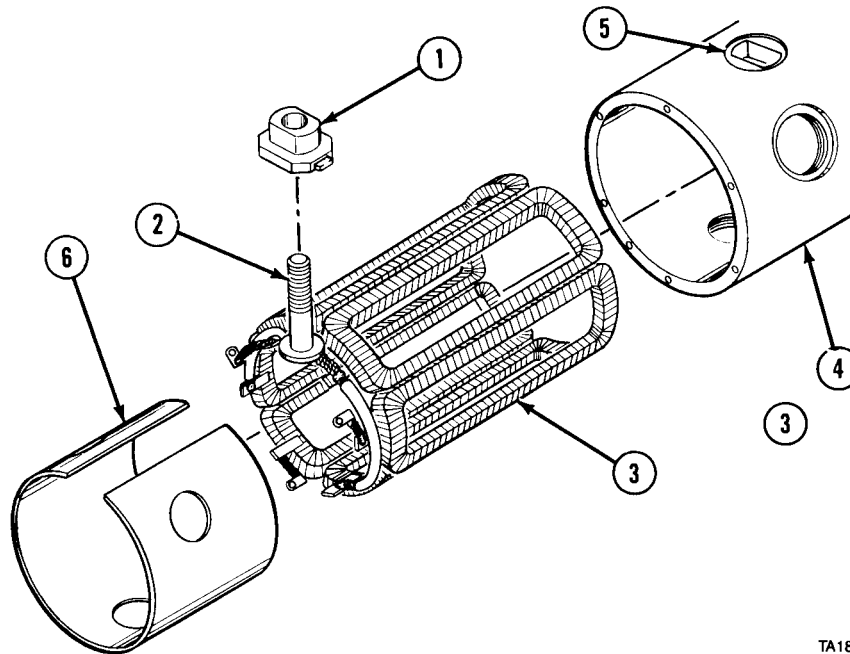

TA188436

- (1) Install insulator bushing (1) on terminal stud (2).
- (2) Install field coil (3) in field frame (4) and put terminal stud (2) through hole (5).
- (3) Aline holes in plate insulator (6) with holes in field frame (4) and install around top of field coil (3).

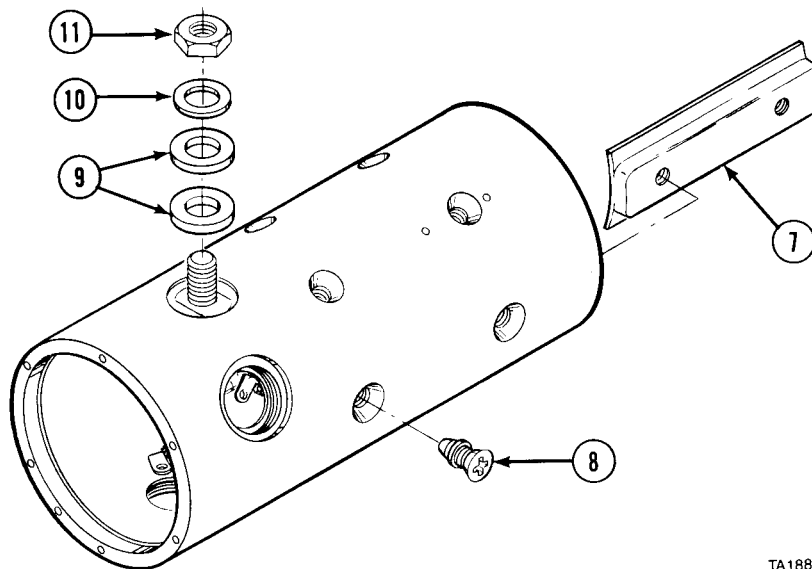

TA188437

- (4) Install six pole shoes (7) with 12 assembled screws (8).
- (5) Install two insulators (9), washer (10), and nut (11).

6-4. STARTER MOTOR REPAIR AND TESTING (CONT).

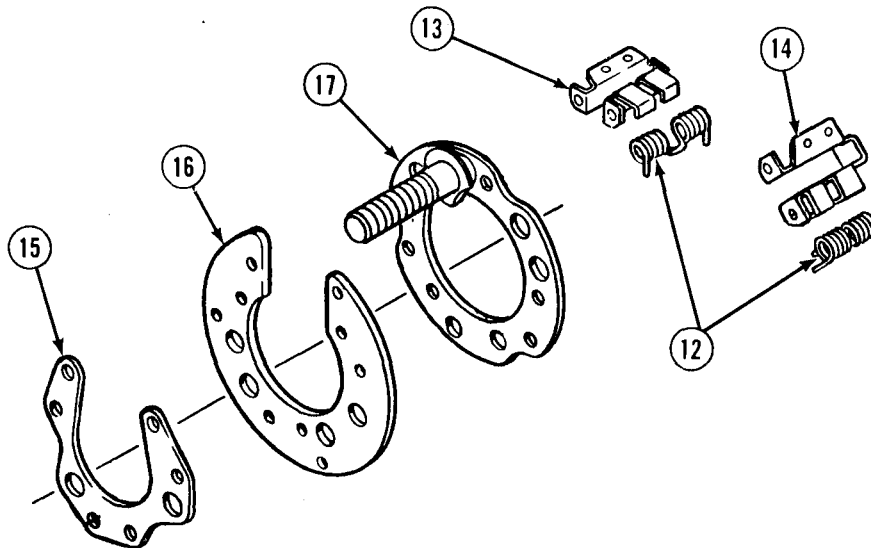

TA188438

- (6) Install six springs (12) on six brush holders (13 and 14).
- (7) Assemble support plate (15), disc insulator (16), and plate assembly (17).

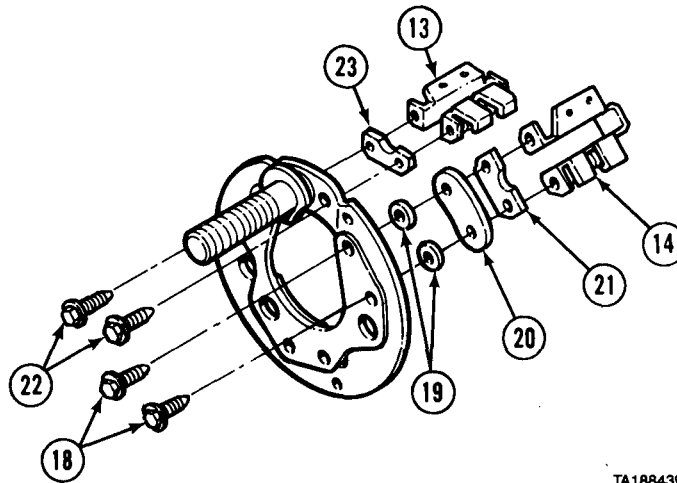

TA188439

- (8) Install two screws (18), two insulators (19), plate insulator (20), plate (21), and brush holder (14).
- (9) Repeat step (8) for two remaining brush holders (14).
- (10) Install two screws (22), plate (23), and brush holder (13).
- (11) Repeat step (10) for remaining two brush holders (13).

Electrical System Maintenance Instructions (Cont)

- (12) Press bushing (24) into end cap (25) flush with top of bore.
- (13) Install preformed packing (26) on end cap (25).

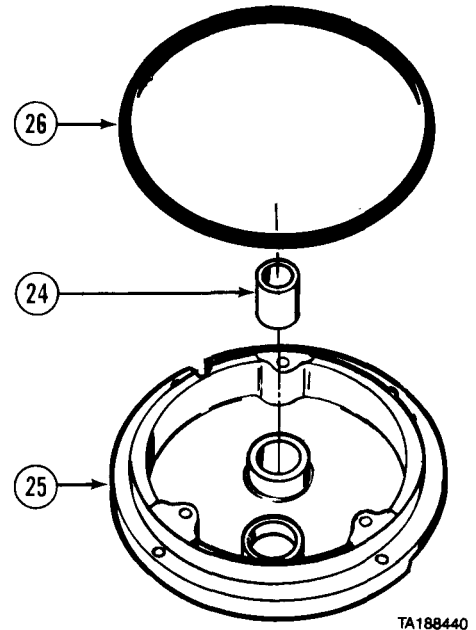

- (14) Install felt wick (27) in end cap (25) and fill with oil.
- (15) Install cup plug (28).

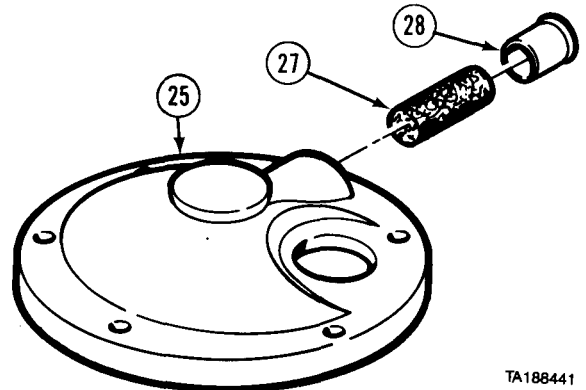

- (16) Install paper gasket (29), two insulating washers (30), and rubber bushing (31) on ground terminal (32) of brush holder (33).

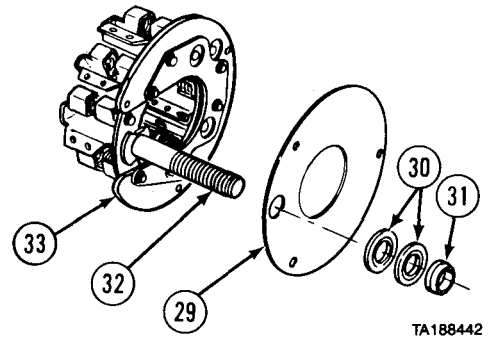

Electrical System Maintenance Instructions (Cont)

6-4. STARTER MOTOR REPAIR AND TESTING (CONT).

- (17) Install brush holder (33) on end cap (25) with three screws (34).

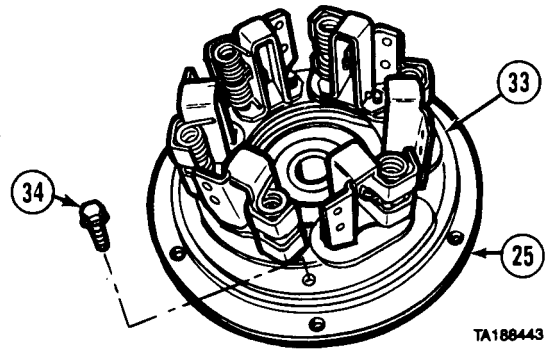

- (18) Install insulator (35), washer (36), lockwasher (37), and nut (38) on ground terminal (32).

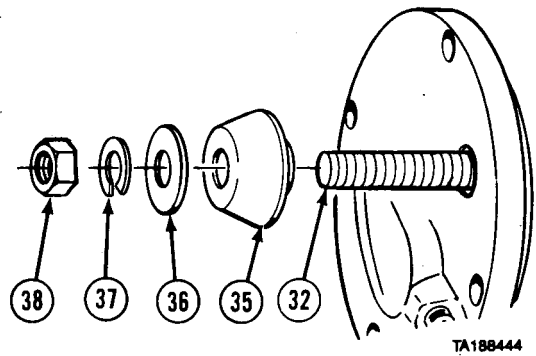

- (19) Install washer (39) on armature shaft (40).
 (20) Install armature (41) into end cap (25).
 (21) Hold six springs (12) and install six brushes (42) with six screws (43).

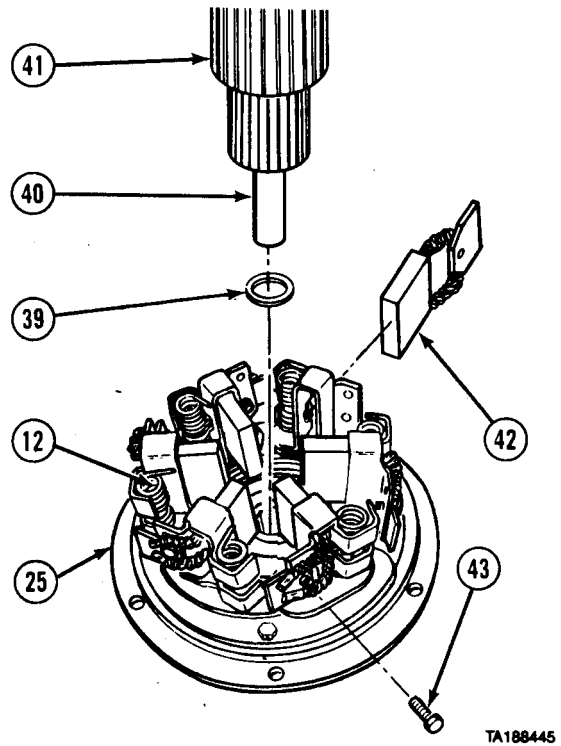

Electrical System Maintenance Instructions (Cent)

- (22) Align hole in bushing (44) with hole in bushing boss and press bushing into lever housing (45).
- (23) Put four drops of epoxy adhesive on back of non-metallic washer (46) and install in lever housing (45).

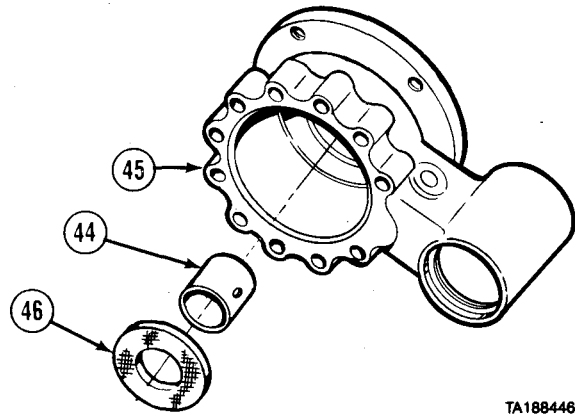

TA188446

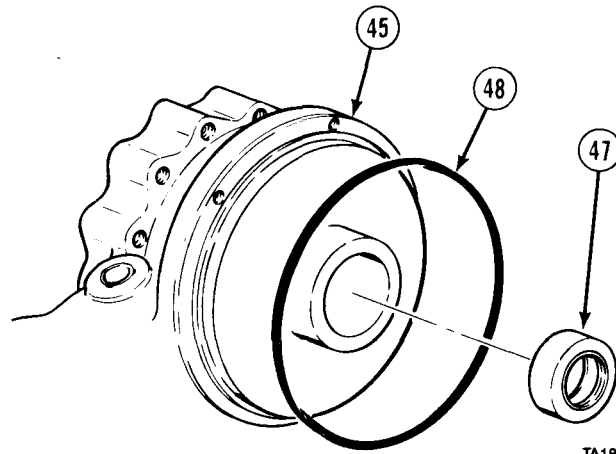

TA188447

- (24) Press oil seal (47) into lever housing (45).
- (25) Install preformed packing (48).

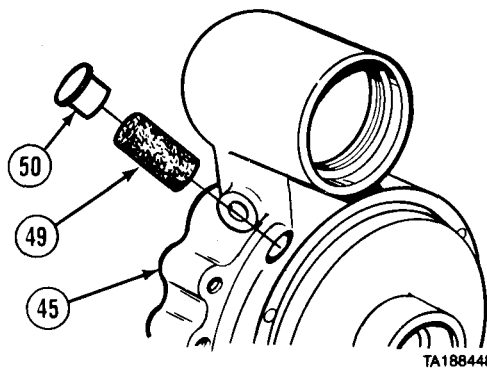

TA188448

- (26) Install felt wick (49) in lever housing (45) and fill with oil.
- (27) Install cup plug (50).

6-4. STARTER MOTOR REPAIR AND TESTING (CONT).

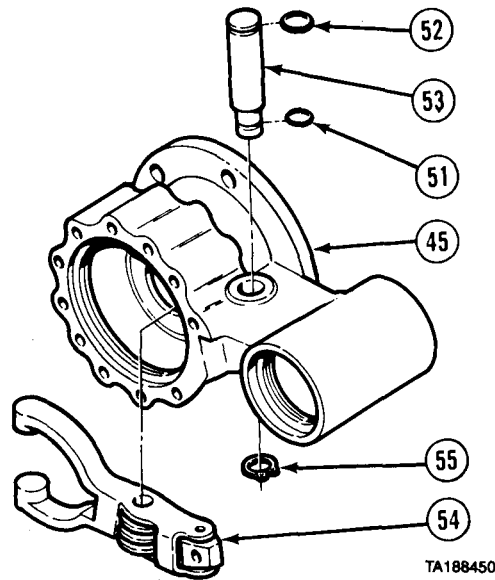

TA188450

- (28) Install small preformed packing (51) and large preformed packing (52) on shift lever shaft (53).
- (29) Install shift lever (54) in lever housing (45).
- (30) Install shift lever shaft (53) through shift lever (54).
- (31) Install retaining ring (55).

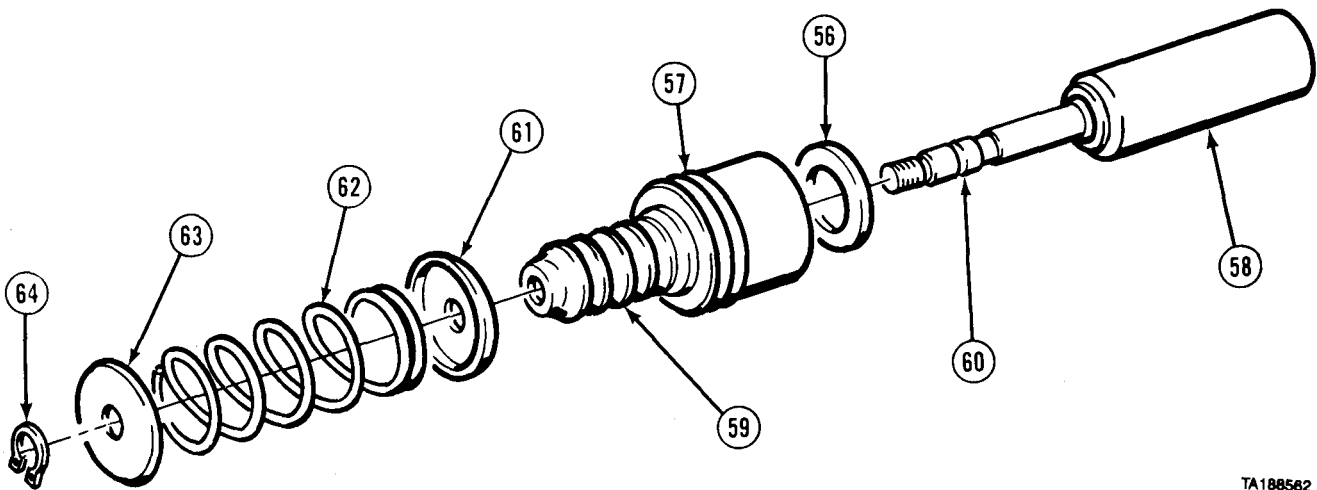

TA188562

- (32) Install washer (56) in boot (57).
- (33) Install boot (57) on plunger (58). Push boot down so collar (59) on boot fits in groove (60).
- (34) Install retainer (61), spring (62), retainer (63), and retaining ring (64).

Electrical System Maintenance Instructions (Cont)

- (35) Install plunger (58) through shift lever (54). Install self-locking nut (65) with same number of turns noted in removal.
- (36) Install gasket (66) and inspection plug (67).

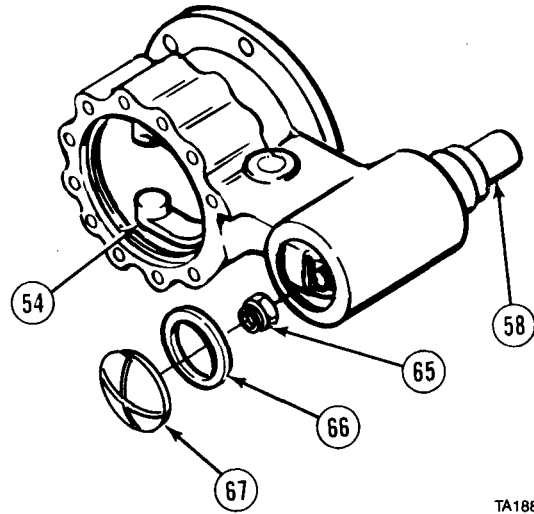

TA188451

- (37) Install preformed packing (68) in lever housing (45).

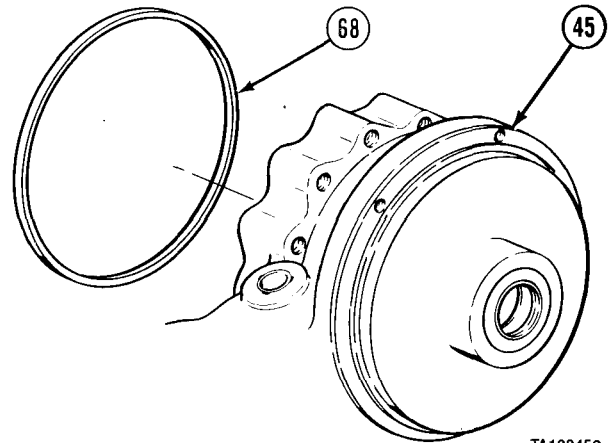

TA188452

- (38) Press bushing (69) into drive housing (70).
- (39) Install six rubber balls (71) into drive housing (70).
- (40) Soak felt wick (72) with oil and install.
- (41) Install cup plug (73).

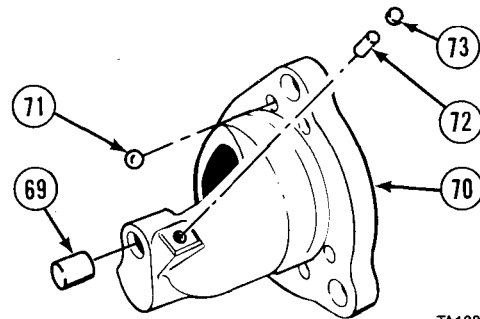

TA188453

6-4. STARTER MOTOR REPAIR AND TESTING (CONT).

- (42) Install starter drive (74) in shift lever (54) in lever housing (45).
- (43) Aline matchmarks and install drive housing (70) on lever housing (45) with five long screws (75) and one short screw (76). Tighten screws to 15 lb-ft (20 N·m).

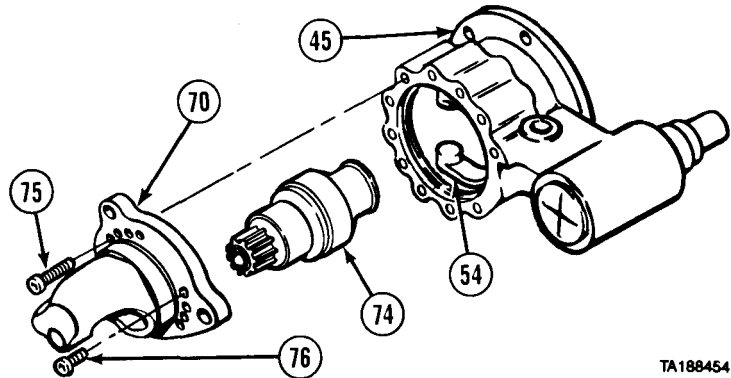

TA188454

- (44) Aline matchmarks and install lever housing (45) on field frame (4) with seven screws (77).

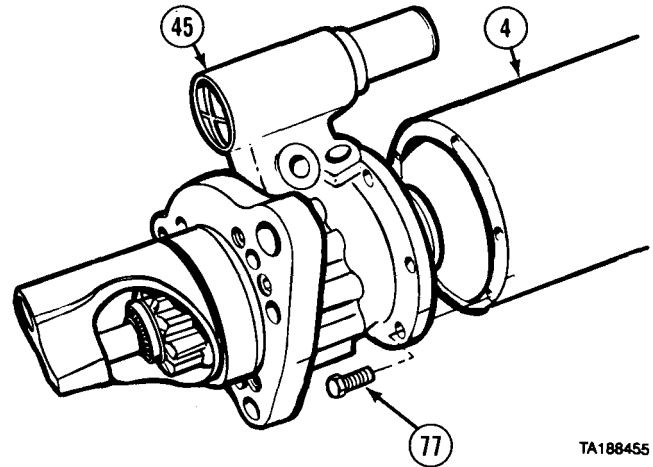

TA188455

- (45) Coat splines (78) of armature (41) with light film of lubricating oil.
- (46) Install thrust washer (79) on long end of armature shaft (40).

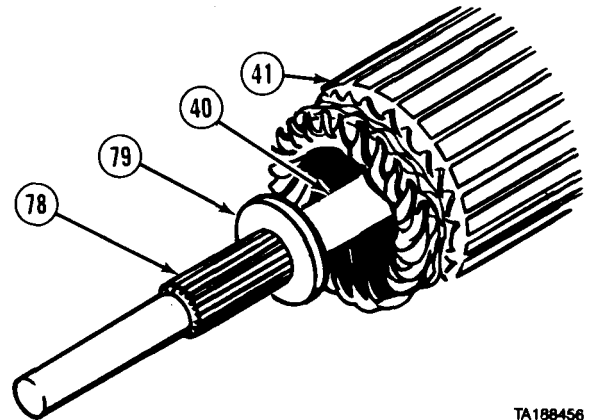

TA188456

Electrical System Maintenance Instructions (Cent)

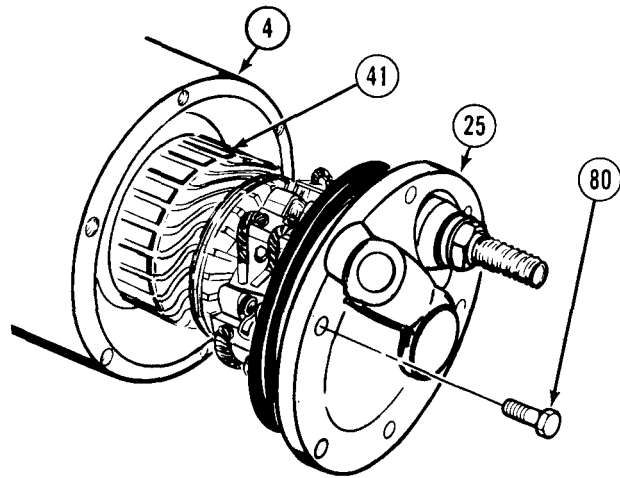

TA188457

(47) Install armature (41) and end cap (25) into field frame (4) with six screws (80).

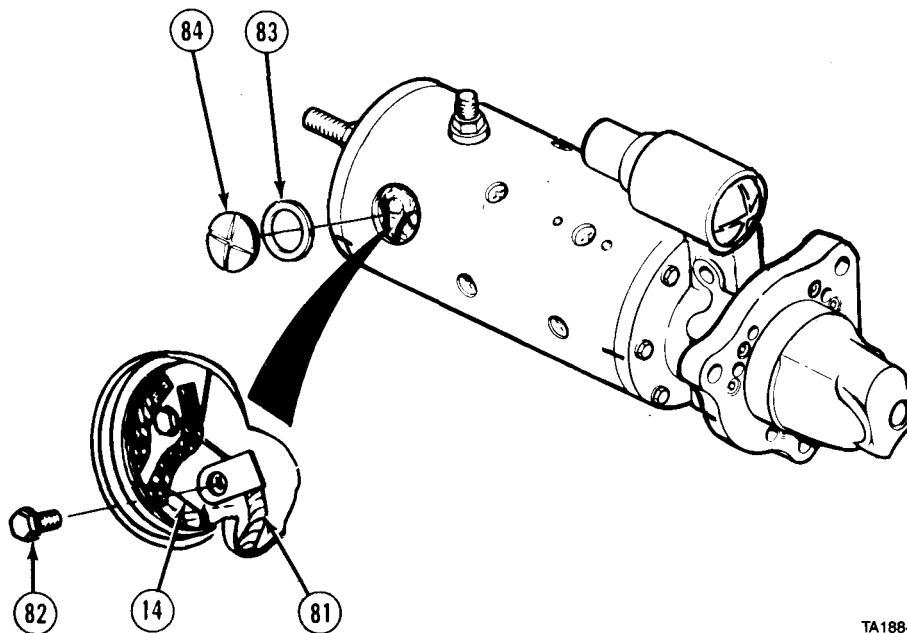

TA188458

(48) Install three field leads (81) to brush holders (14) with three screws (82).

(49) Install gasket (83) and inspection plug (84).

e. Follow-on Maintenance. None.

END OF TASK

Electrical System Maintenance Instructions (Cent)

Section III. CRANE SYSTEM ELECTRICAL

6-5. VISUAL AND AUDIBLE LEVEL WARNING INDICATORS REMOVAL/INSTALLATION (M983).

This task covers:

- a. Removal
- b. Installation
- c. Follow-on Maintenance

INITIAL SETUP

Models

M983 with crane

Test Equipment

None

Special Tools

None

Supplies

Connector, electrical butt, Item 31, Appendix C
 Tags, identification, Item 60, Appendix C

Personnel Required

MOS 63W, Wheel vehicle repairer

References

None

Equipment Condition

<i>TM or Para</i>	<i>Condition Description</i>
TM 9-2320-279-10	Crane in transport position.
TM 9-2320-279-20	Batteries disconnected.

Special Environmental Conditions

None

General Safety Instructions

None

Level of Maintenance

Direct Support

a. Removal.

NOTE

- Left and right visual and audible level warning indicators are removed in a similar manner.
- Audible level warning alarm is on left side only.

- (1) Remove two nuts (1), washers (2), and screws (3).
- (2) Remove indicator (4) and alarm (5) from bracket (6).

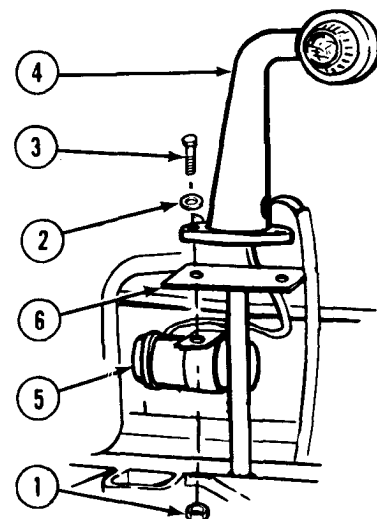
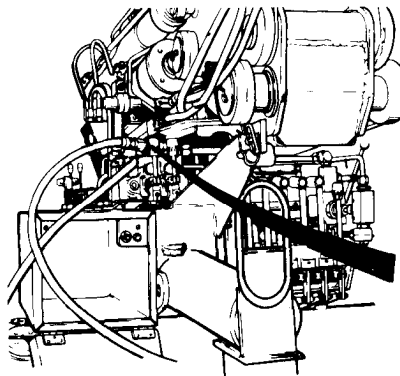

TA187806

Electrical System Maintenance Instructions (Cont)

NOTE

- Left side visual and audible level warning indicator (with alarm) has three sets of two wires. Right side visual level warning indicator has two sets of two wires.
- Tag and mark wires.
 - (3) Pull wires (7) from base (8) of indicator (4).
 - Disconnect wires.
 - (4) Note position and remove wires (7) from holes in indicator (4). Remove indicators from vehicle.

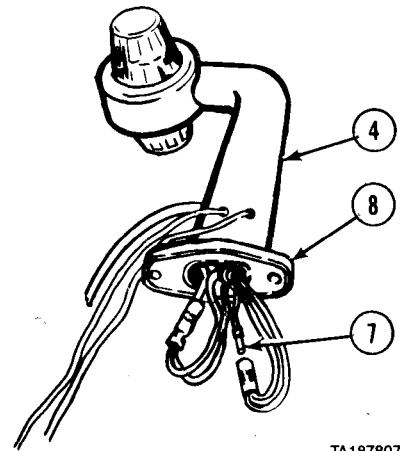

TA187807

NOTE

Indicator lenses and lamps are removed the same way from both indicators.

- (5) Remove two amber lenses (9) and lamp (10) from indicator (4).

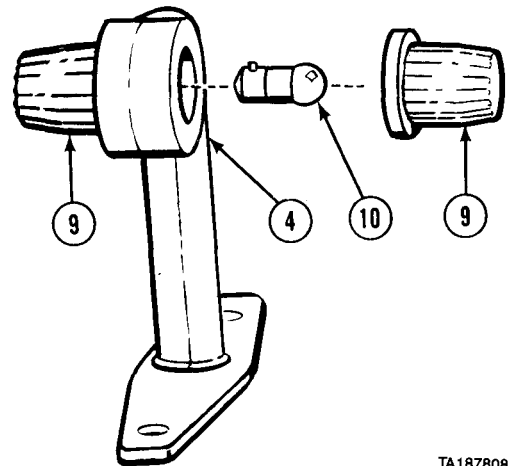

TA187808

b. Installation.

NOTE

Lamps and amber lenses are installed the same way on both indicators.

- (1) Install lamp (1) and two amber lenses (2) in indicator (3).

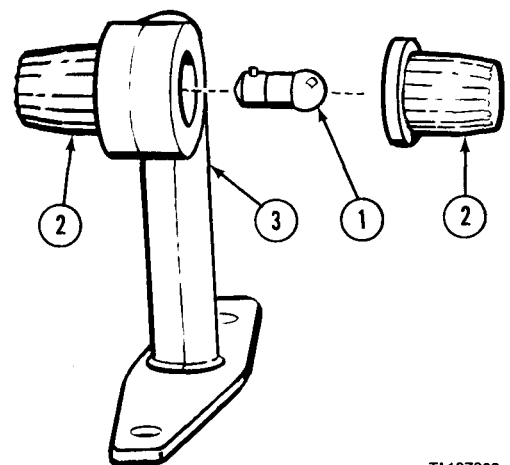

TA187809

6-5. VISUAL AND AUDIBLE LEVEL WARNING INDICATORS REMOVAL/INSTALLATION (M983) (CONT).

NOTE

- Left and right visual and audible level warning indicators are installed in a similar manner.
- Left side visual and audible level warning indicator (with alarm) has three sets of two wires. Right side visual level warning indicator has two sets of two wires.

- (2) Install wires (4) in holes on indicator (3).
- (3) Pull wires (4) through base (5) of indicator (3) and connect.
- (4) Install wires (4) back in base (5).

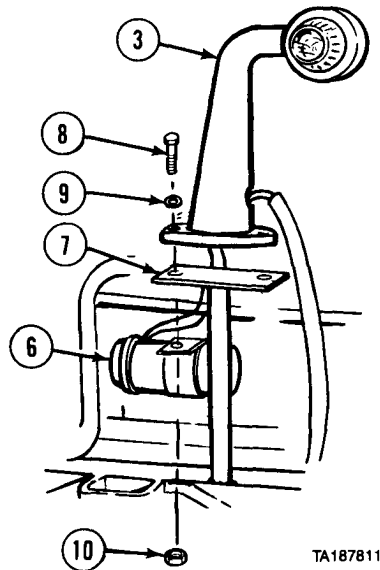
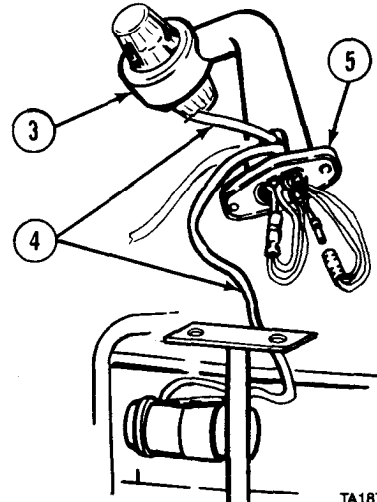

NOTE

Audible level warning alarm is on left side only.

- (5) Install indicator (3) and alarm (6) on support base (7) with two screws (8), washers (9), and nuts (10).

c. Follow-on Maintenance. Connect batteries (TM 9-2320-279-20).

END OF TASK

Electrical System Maintenance Instructions (Cont)

6-6. OUTRIGGER EXTENDED SWITCH REMOVAL/INSTALLATION (M983).

This task covers:

- a. Removal
- b. Installation
- c. Follow-on Maintenance

INITIAL SETUP

Models

M983 with crane

Test Equipment

None

Special Tools

None

Supplies

Tags, identification, Item 60, Appendix C

Personnel Required

MOS 63W, Wheel vehicle repairer

References

None

Equipment Condition

<i>TM or Para</i>	<i>Condition Description</i>
TM 9-2320-279-10	Outriggers extended.
TM 9-2320-279-20	Batteries disconnected.

Special Environmental Conditions

None

General Safety Instructions

None

Level of Maintenance

Direct Support

a. Removal.

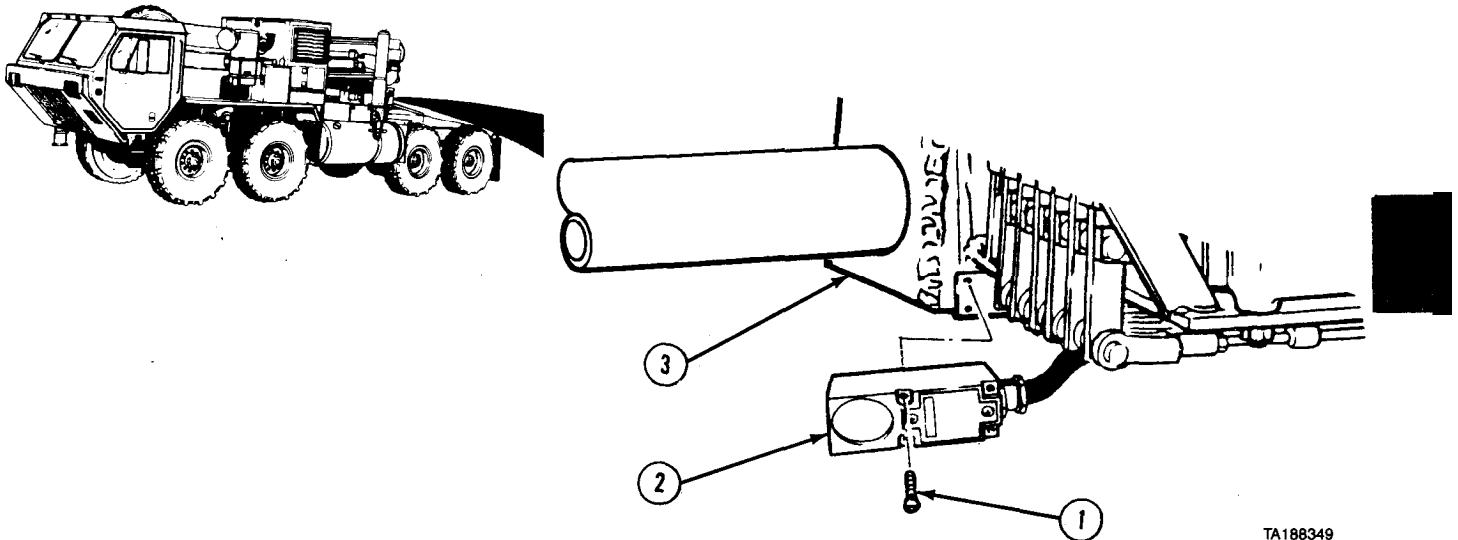

NOTE

Left and right outrigger extended switches are removed the same way.

- (1) Remove four screws (1) and switch (2) from outrigger support beam (3).

6-6. OUTRIGGER EXTENDED SWITCH REMOVAL/INSTALLATION (M983) (CONT).

- (2) Remove two screws (4) and access cover (5) from switch (2).

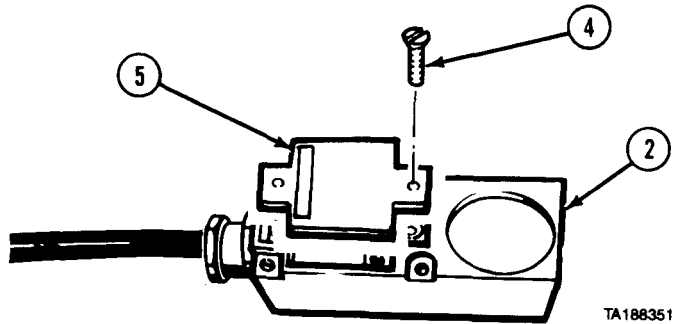

- (3) Loosen jamnut (6) and slide down cable (7).

NOTE

Tag and mark wires before removal.

- (4) Remove three screws (8) from spade lugs (9) and wires (10).

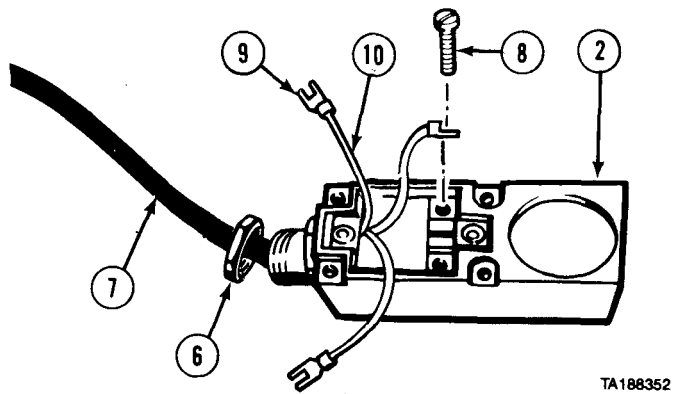

b. Installation.

NOTE

Left and right outrigger extended switches are installed the same way.

- (1) Install three wires (1) and position spade lugs (2) over screw holes on switch (3).
- (2) Install three spade lugs (2) with three screws (4).
- (3) Install jamnut (5) on switch (3).

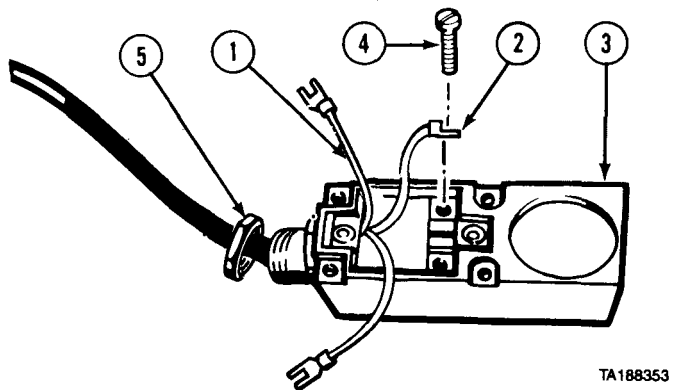

- (4) Install access cover (6) with two screws (7) on switch (3).

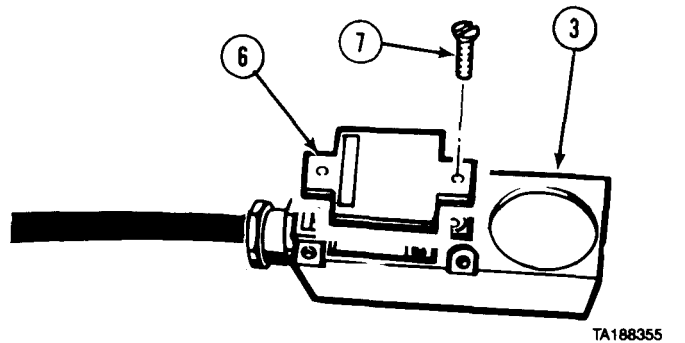

Electrical System Maintenance Instructions (Cont)

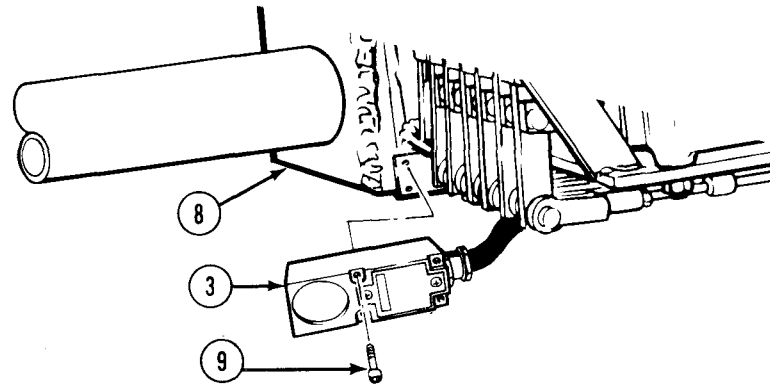

TA188356

(5) Position switch (3) on outrigger support beam (8) with four screws (9).

c. Follow-on Maintenance.

- (1) Connect batteries (TM 9-2320-279-20).
- (2) Stow outriggers (TM 9-2320-279-10).

END OF TASK

6-7. TILT WARNING ALARM SWITCH REMOVAL/INSTALLATION (M983).	
This task covers:	
a. Removal b. Installation	c. Follow-on Maintenance
INITIAL SETUP	
<i>Models</i> M983 with crane	<i>Equipment Condition</i> <i>TM or Para</i> <i>Condition Description</i> TM 9-2320-279-10 Crane in transport position. TM 9-2320-279-20 Batteries disconnected.
<i>Test Equipment</i> None	<i>Special Environmental Conditions</i> None
<i>Special Tools</i> None	<i>General Safety Instructions</i> None
<i>Supplies</i> Tags, identification, Item 60, Appendix C	<i>Level of Maintenance</i> Direct Support
<i>Personnel Required</i> MOS 63W, Wheel vehicle repairer	
<i>References</i> None	

6-7. TILT WARNING ALARM SWITCH REMOVAL/INSTALLATION (M983) (CONT).

a. Removal.

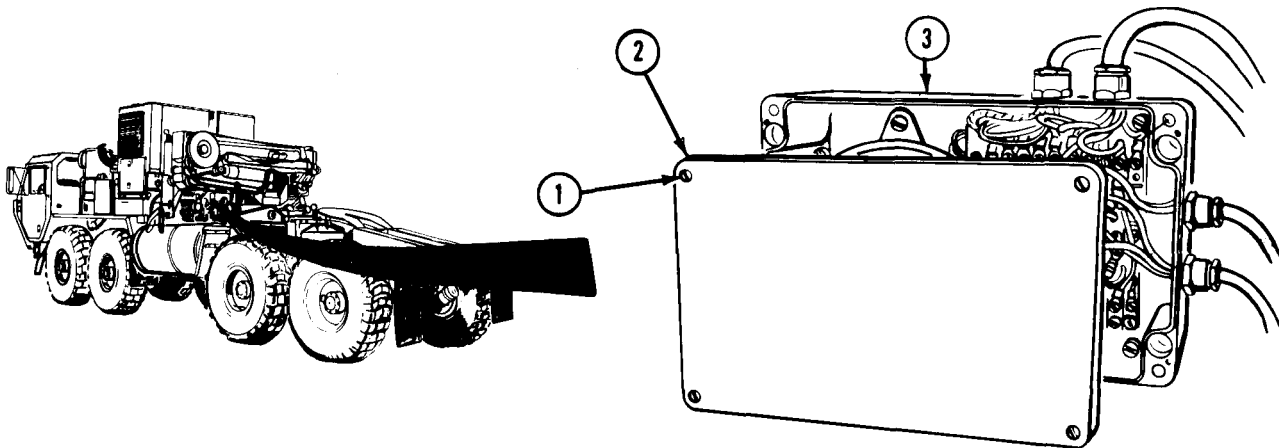

TA187824

WARNING

- Always make sure electrical power is off before working on electrical connections. Serious injury or death could result from electrical shock.
- Remove rings, bracelets, wristwatches, neck chains, and any other jewelry before working around vehicle. Jewelry can catch on equipment and cause injury, or may short across an electrical circuit and cause severe burns or electrical shock.

(1) Remove four screws (1) and cover (2) from tilt warning box (3).

NOTE

Tag and mark wires before removal.

- (2) Remove three screws (4) and four wires (5).
- (3) Remove three screws (6) and tilt warning switch (7) from tilt warning box (3).

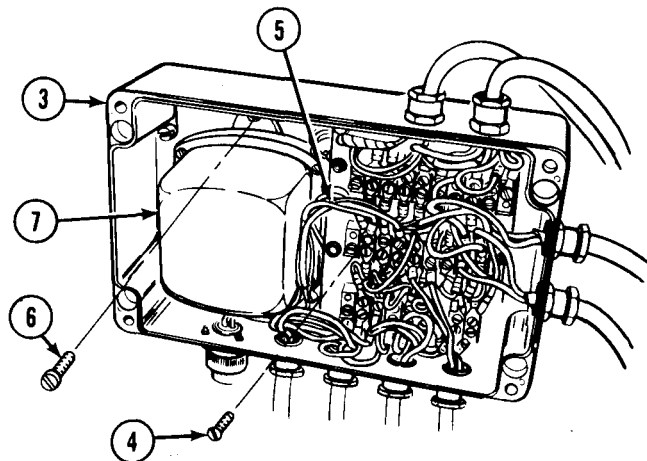

TA187825

Electrical System Maintenance Instructions (Cont)

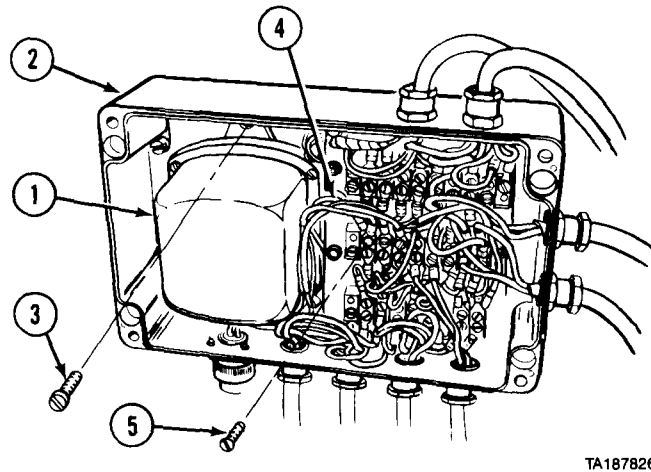
b. Installation.

TA187826

WARNING

- Always make sure electrical power is off before working on electrical connections. Serious injury or death could result from electrical shock.
- Remove rings, bracelets, wristwatches, neck chains, and any other jewelry before working around vehicle. Jewelry can catch on equipment and cause injury, or may short across an electrical circuit and cause severe burns or electrical shock.

- (1) Install tilt warning switch (1) in tilt warning box (2) with three screws (3).
 (2) Install four wires (4) with three screws (5).

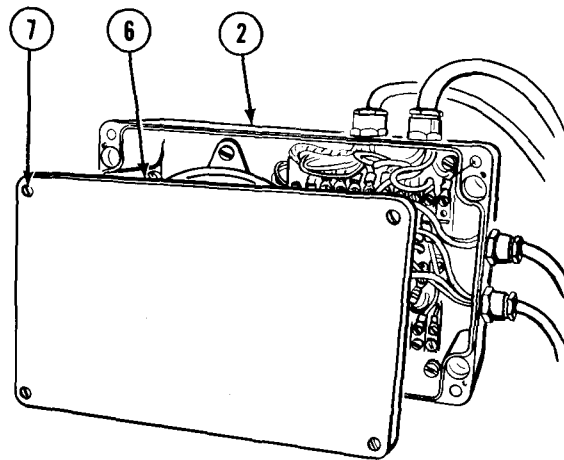

TA187827

- (3) Install cover (6) on tilt warning box (2) and tighten four screws (7).

c. Follow-on Maintenance. Connect batteries (TM 9-2320-279-20).**END OF TASK**

Electrical System Maintenance Instructions (Cont)

6-8. CRANE CONTROL DISTRIBUTION BOARD REMOVAL/INSTALLATION (M983).

This task covers:

- a. Removal
- b. Inspection
- c. Installation
- d. Follow-on Maintenance

INITIAL SETUP

Models

M983 with crane

Test Equipment

None

Special Tools

None

Supplies

Tags, identification, Item 60, Appendix C

Personnel Required

MOS 63W, Wheel vehicle repairer

References

None

Equipment Condition

TM or Para

Condition Description

TM 9-2320-279-10

Crane in transport position.

TM 9-2320-279-20

Batteries disconnected.

Special Environmental Conditions

None

General Safety Instructions

None

Level of Maintenance

Direct Support

a. Removal.

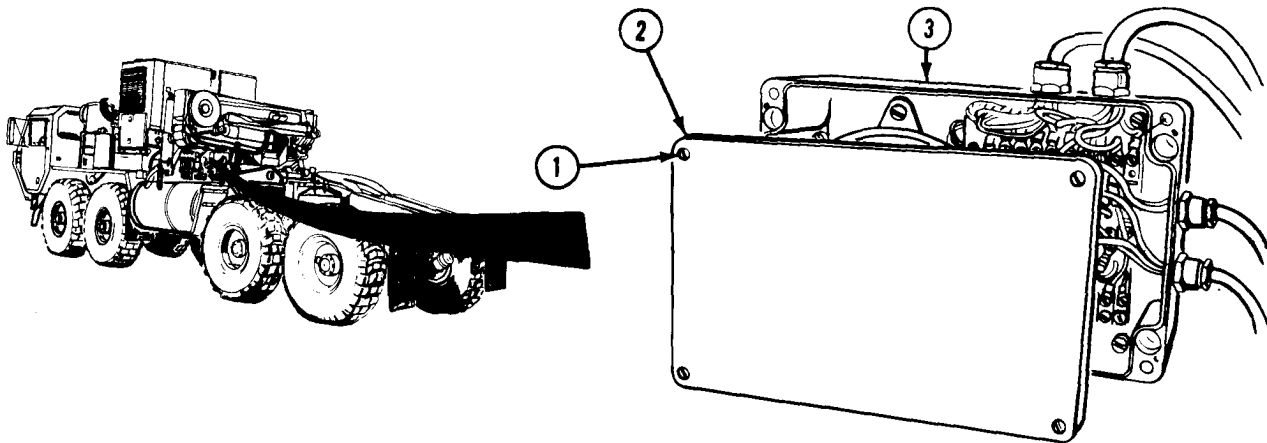

TA187887

WARNING

- Always make sure electrical power is off before working on electrical connections. Serious injury or death could result from electrical shock.
- Remove rings, bracelets, wristwatches, neck chains, and any other jewelry before working around the vehicle. Jewelry can catch on equipment and cause injury, or may short across an electrical circuit and cause severe burns or electrical shock.

(1) Loosen four screws (1) and remove cover (2) from tilt warning box (3).

Electrical System Maintenance Instructions (Cont)

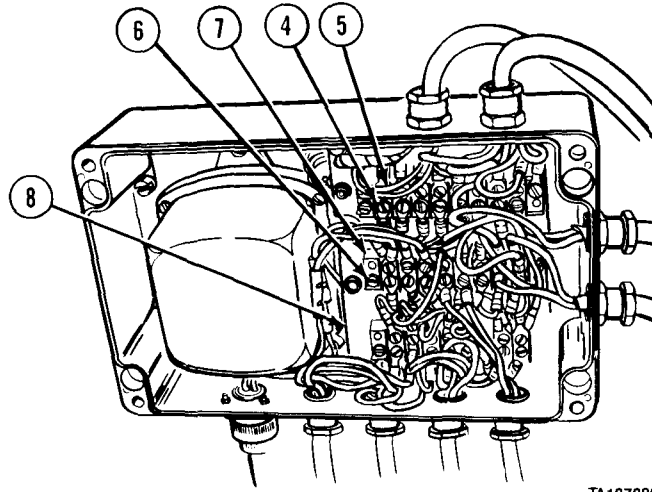

TA187888

NOTE

Tag and mark wires before removal.

- (2) Remove screws (4) and wires (5) as needed.
- (3) Remove screws (6) and three terminal strips (7) from distribution board (8).

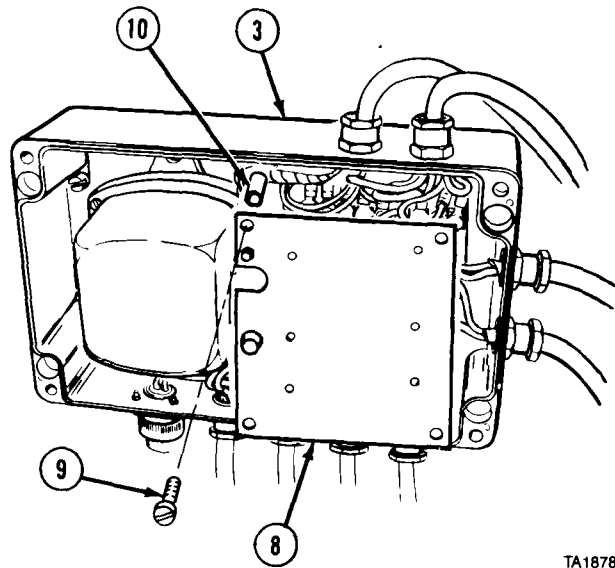

TA187889

- (4) Remove four screws (9), distribution board (8), and four spacers (10) from tilt warning box (3).

6-8. CRANE CONTROL DISTRIBUTION BOARD REMOVAL/INSTALLATION (M983) (CONT).

NOTE

Tag and mark wires before removal.

- (5) Turn distribution board (8) over and remove 12 screws (11) and wires (12) from terminal block (13).
- (6) Remove nut (14), lockwasher (15), and potentiometer (16).
- (7) Remove nut (17), washer (18), and no-overload lamp (19) from distribution board (8).
- (8) Remove four screws (20), overload protection circuit board (21), and four spacers (22) from distribution board (8).

b. Inspection.

- (1) Inspect boards and terminal strips for damage. Replace damaged parts.
- (2) Check wires for damage, loose or broken connections, or damaged insulation. Replace defective wiring or connections.
- (3) Check each wire for continuity. If open circuit or high resistance, replace defective wire or cable.

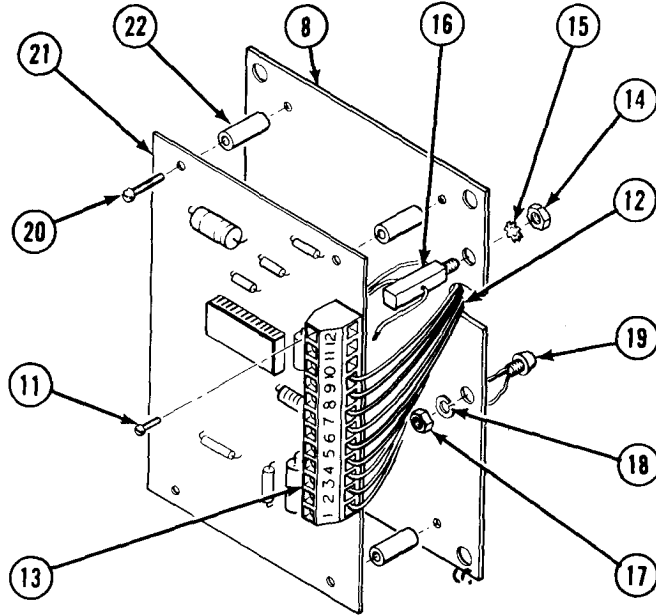

TA187890

c. Installation.

WARNING

- Always make sure electrical power is off before working on electrical connections. Serious injury or death could result from electrical shock.
- Remove rings, bracelets, wristwatches, neck chains, and any other jewelry before working around vehicle. Jewelry can catch on equipment and cause injury, or may short across an electrical circuit and cause severe burns or electrical shock.

- (1) Install overload protection circuit board (1) on distribution board (2) with four spacers (3) and screws (4).
- (2) Install no-overload lamp (5) with washer (6) and nut (7).
- (3) Install potentiometer (8) with lockwasher (9) and nut (10).
- (4) Install 12 wires (11) in terminal block (12) with 12 screws (13).

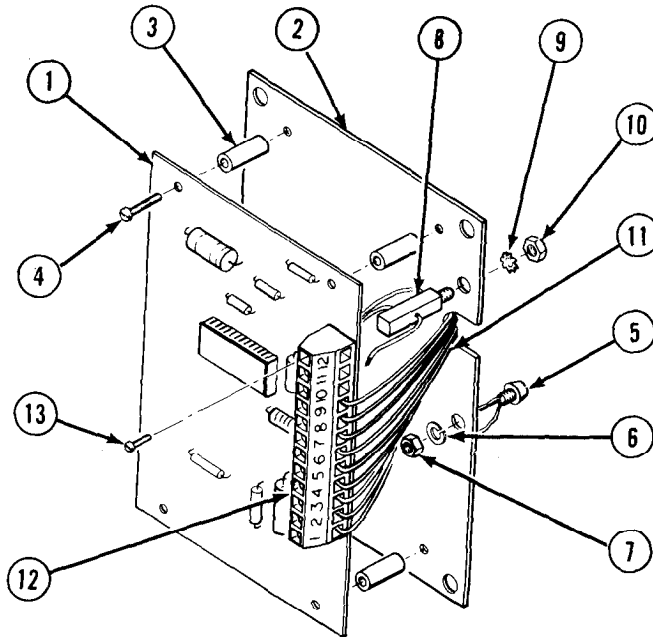

TA187891

Electrical System Maintenance Instructions (Cont)

- (5) Install four spacers (14) and distribution board (2) in tilt warning box (15) with four screws (16).

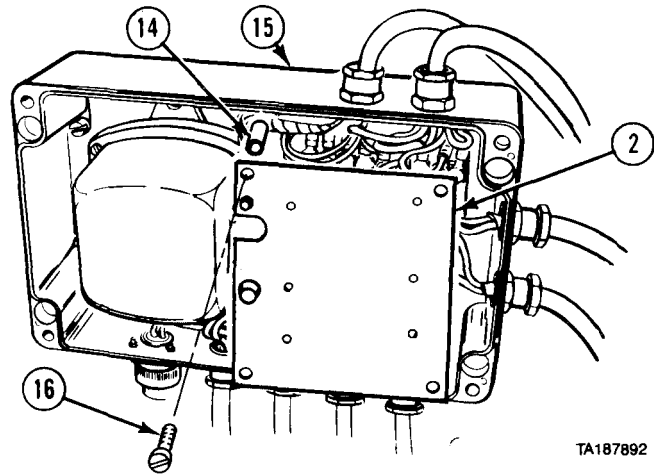

TA187892

- (6) Install three terminal strips (17) on distribution board (2) with screws (18).
 (7) Install wires (19) with screws (20).

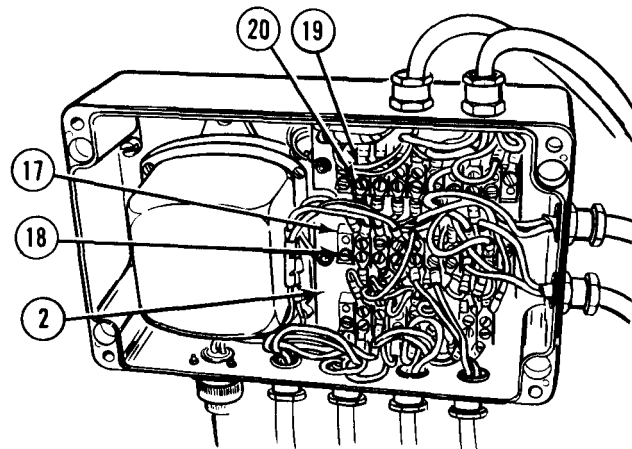

TA187893

- (8) Install cover (21) on tilt warning box (15) with four screws (22).

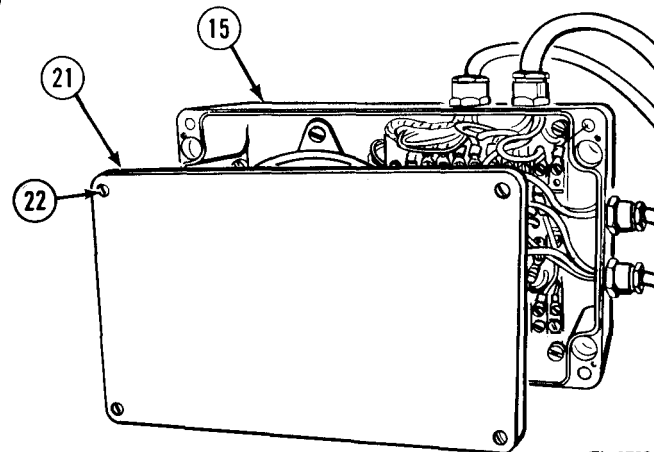

TA187894

d. Follow-on Maintenance. Connect batteries (TM 9-2320-279-20).

END OF TASK

Electrical System Maintenance Instructions (Cont)

6-9. POWER INTERCONNECTING CABLES REMOVAL/INSTALLATION (M983).

This task covers:

- a. Removal
- b. Inspection
- c. Installation
- d. Follow-on Maintenance

INITIAL SETUP

Models

M983 with crane

Test Equipment

None

Special Tools

None

Supplies

Tags, identification, Item 60, Appendix C
Ties, cable, plastic, Item 65, Appendix C

Personnel Required

MOS 63W, Wheel vehicle repairer

References

None

Equipment Condition

TM or Para

TM 9-2320-279-10

TM 9-2320-279-20

Para 6-6

Para 6-5

Para 18-46

Condition Description

Crane in transport position.

Batteries disconnected.

Left and right outrigger extended switches removed.

Left and right visual and audible level warning indicators removed.

Remote control power switch removed.

Special Environmental Conditions

None

General Safety Instructions

None

Level of Maintenance

Direct Support

a. Removal.

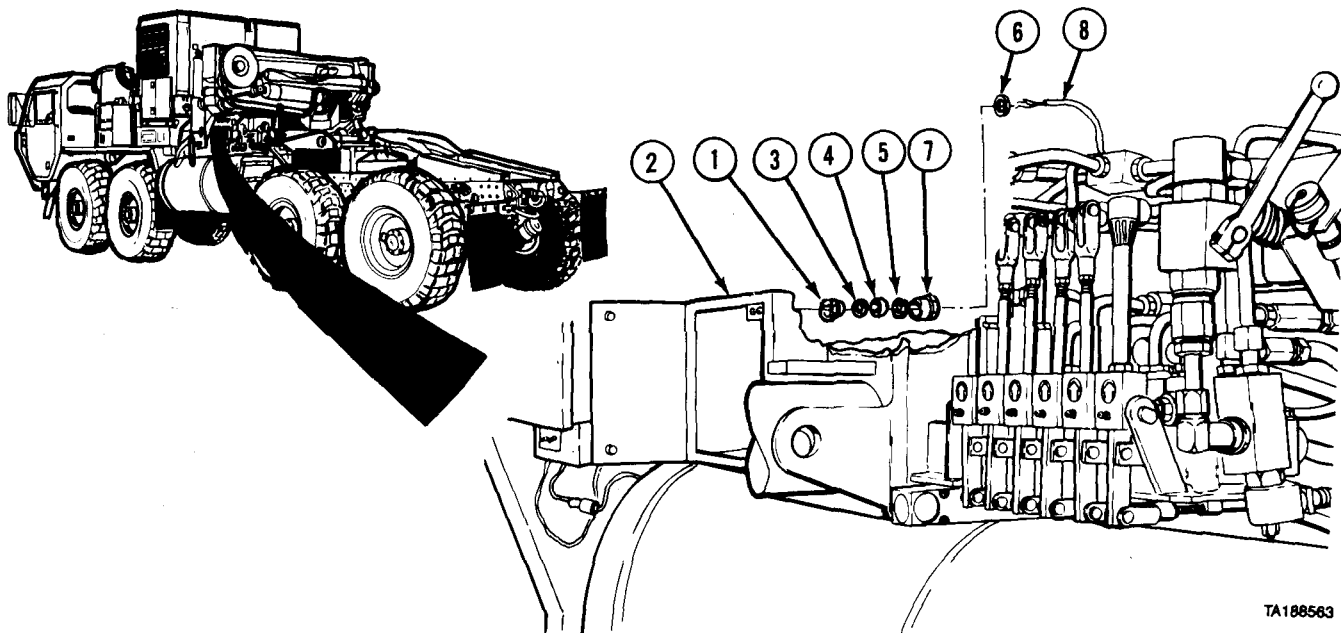

TA188563

Electrical System Maintenance Instructions (Cont)

WARNING

- Always make sure electrical power is off before working on electrical connections. Serious injury or death could result from electrical shock.
- Remove rings, bracelets, wristwatches, neck chains, and any other jewelry before working around vehicle. Jewelry can catch on equipment and cause injury, or may short across an electrical circuit and cause severe burns or electrical shock.

NOTE

Cut and remove plastic cable ties as needed.

- (1) Loosen jamnut (1) inside stowage box (2) and slide jamnut, washer (3), grommet (4), and washer (5) toward front of stowage box.
- (2) Remove jamnut (6) and slide fitting (7) toward front of stowage box (2).
- (3) Remove control box cable (8) from stowage box (2).

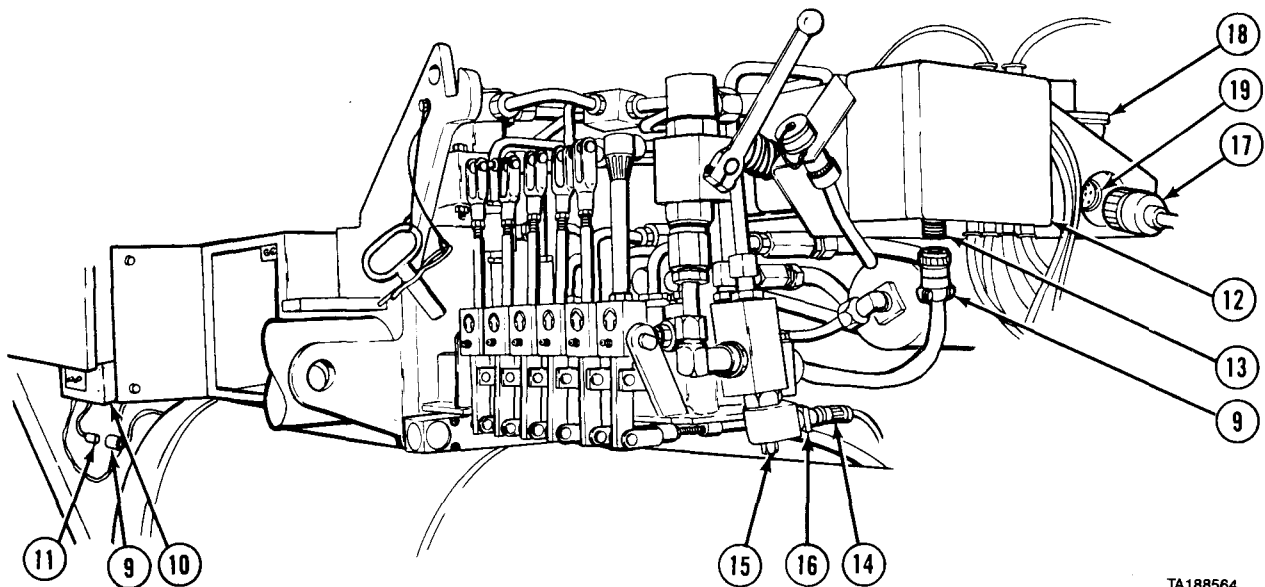

TA188564

NOTE

Tag and mark cables before disconnecting.

- (4) Disconnect power cable (9) from control box (10) at plug (11).
- (5) Disconnect power cable (9) from tilt warning box (12) at connector (13). Remove power cable from vehicle.
- (6) Disconnect dump valve cable (14) from dump valve (15) at connector (16).
- (7) Disconnect remote control power cable (17) from power distribution box (18) at connector (19).

6-9. POWER INTERCONNECTING CABLES REMOVAL/INSTALLATION (M983) (CONT).

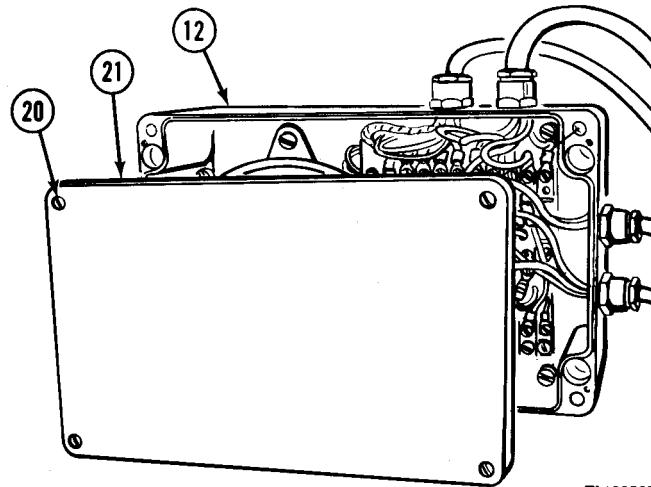

TA188565

(8) Loosen four screws (20) and remove cover (21) from tilt warning box (12).

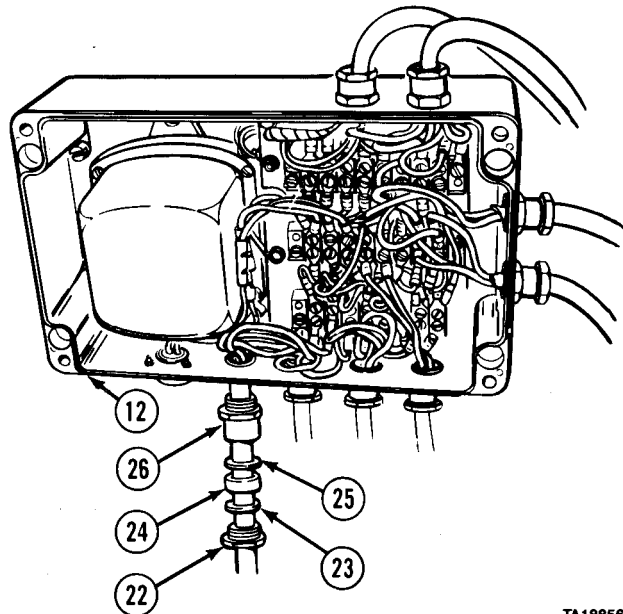

TA188566

NOTE

All cable fittings are removed the same way. Do steps (9) and (10) for each cable.

- (9) Loosen jamnut (22) and slide jamnut, washer (23), grommet (24), and washer (25) away from tilt warning box (12).
- (10) Remove fitting (26) and slide away from tilt warning box (12).

Electrical System Maintenance Instructions (Cont)

NOTE

Tag and mark wires before removal.

- (11) Remove screws (27) and wires (28) as needed.
- (12) Remove right and left visual and audible level sensor warning cables (29 and 30) from tilt warning box (12) and vehicle.
- (13) Remove control box cable (8) from tilt warning box (12) and vehicle.
- (14) Remove dump valve cable (14) from tilt warning box (12) and vehicle.
- (15) Remove right and left outrigger extended switch cables (31 and 32) from tilt warning box (12) and vehicle.
- (16) Remove remote control power cable (17) from tilt warning box (12) and vehicle.
- (17) Remove overload protection cable (33) from tilt warning box (12).

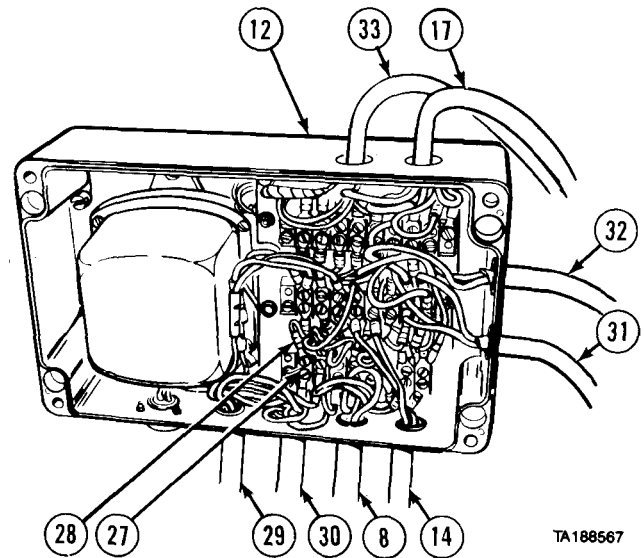

b. Inspection.

- (1) Check each wire in cable for continuity. If open circuit or high resistance, replace defective wire or cable.
- (2) Inspect cable for loose or broken connections and lugs. Inspect for kinks in cable, chafed insulation, or broken insulation.
- (3) Replace damaged connections or terminal lugs.

c. Installation.

- (1) Install overload protection cable (1) in tilt warning box (2).
- (2) Install remote control power cable (3) in tilt warning box (2).
- (3) Install left and right outrigger extended switch cables (4 and 5) in tilt warning box (2).
- (4) Install dump valve cable (6) in tilt warning box (2).
- (5) Install control box cable (7) in tilt warning box (2).
- (6) Install left and right visual and audible level sensor warning cables (8 and 9) in tilt warning box (2).
- (7) Install wires (10) and screws (11).

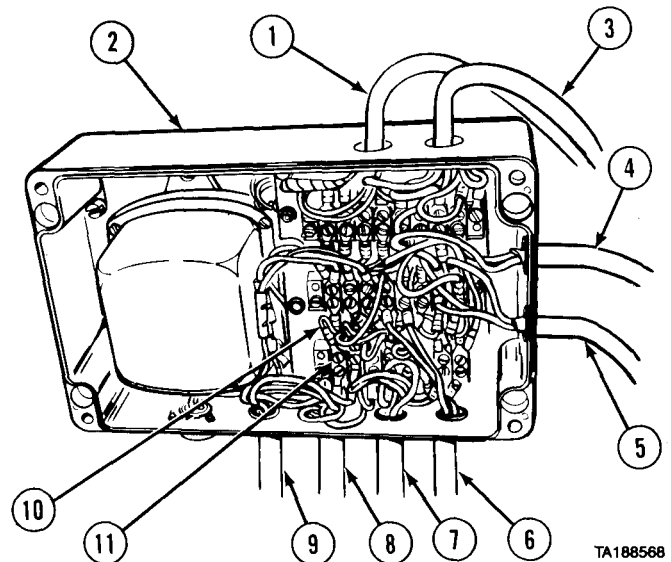

6-9. POWER INTERCONNECTING CABLES REMOVAL/INSTALLATION (M983) (CONT).

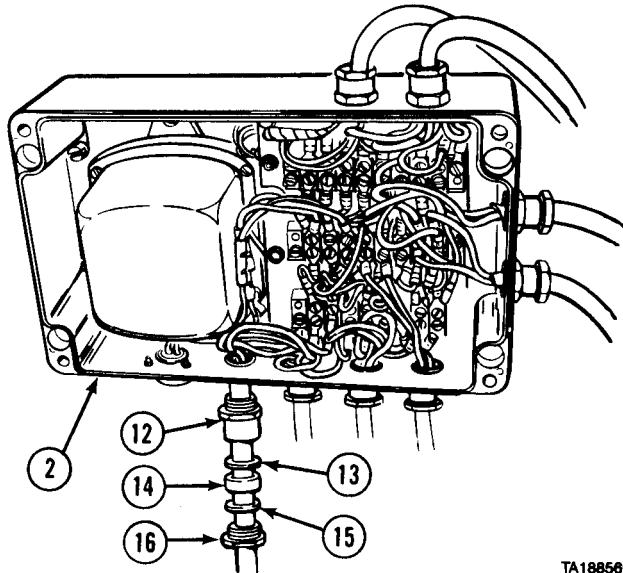

NOTE

All cable fittings are installed the same way. Do steps (8) and (9) for each cable.

(8) Install fitting (12) in tilt warning box (2).

(9) Install washer (13), grommet (14), and washer (15) in fitting (12) with jamnut (16).

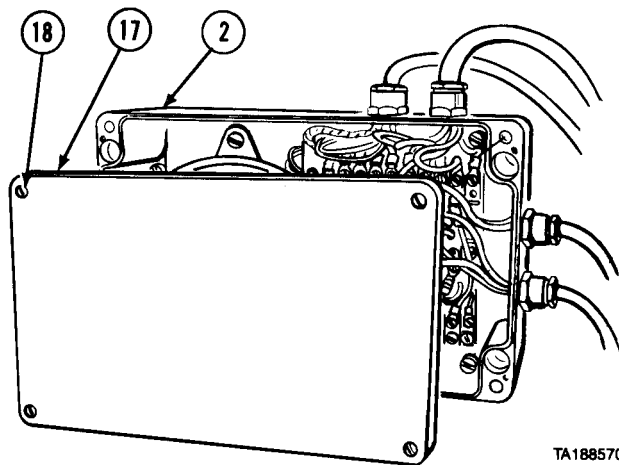

(10) Install cover (17) on tilt warning box (2) and tighten four screws (18).

Electrical System Maintenance Instructions (Cont)

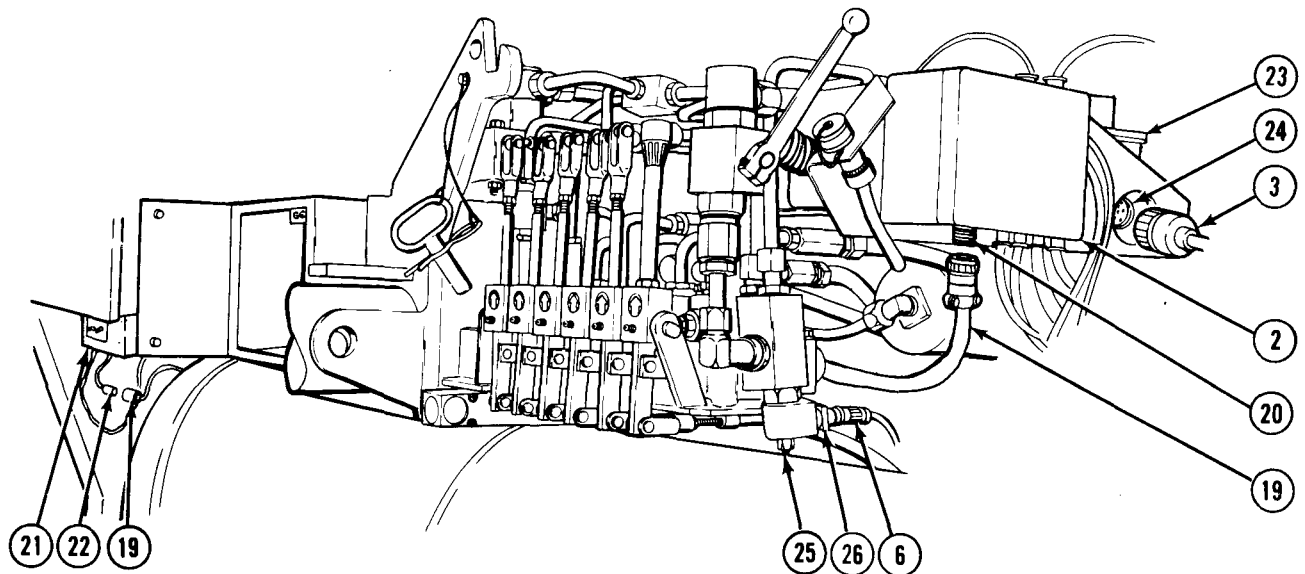

TA188571

NOTE

Route cables through vehicle and secure with plastic cable ties as needed.

- (11) Connect power cable (19) on tilt warning box (2) at connector (20).
- (12) Connect power cable (19) on control box (21) at plug (22).
- (13) Connect remote control power cable (3) on power distribution box (23) at connector (24).
- (14) Connect dump valve cable (6) on dump valve (25) at connector (26).
- (15) Install control box cable (7) in storage box (27) with fitting (28) and jamnut (29).
- (16) Install washer (30), grommet (31), and washer (32) with jamnut (33).

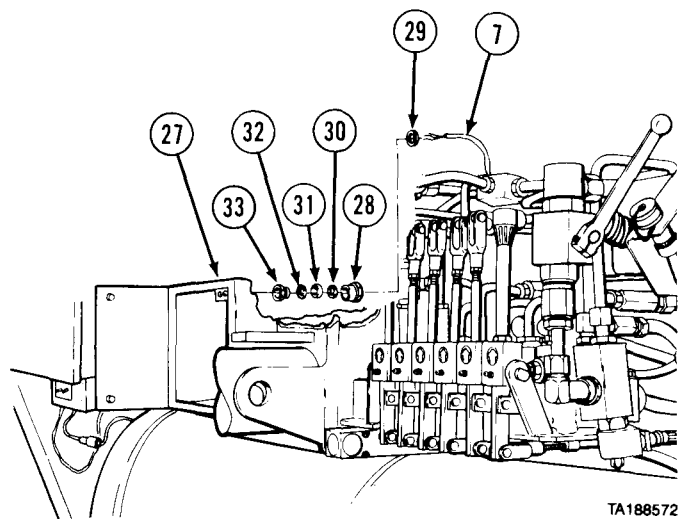

TA188572

d. Follow-on Maintenance.

- (1) Install left and right visual and audible level warning sensors (para 6-5).
- (2) Install left and right outrigger extended switches (para 6-6).
- (3) Install remote control power switch (para 18-46).
- (4) Connect batteries (TM 9-2320-279-20).

END OF TASK

6-10. TILT ALARM BOX REMOVAL/INSTALLATION (M983).

This task covers:

- a. Removal
- b. Cleaning/Inspection
- c. Installation
- d. Follow-on Maintenance

INITIAL SETUP

<i>Models</i>	<i>Equipment Condition</i>	
M983 with crane	<i>TM or Para</i>	<i>Condition Description</i>
<i>Test Equipment</i>	Para 6-7	Tilt warning alarm removed.
None	Para 6-8	Crane control distribution board removed.
<i>Special Tools</i>	Para 6-9	Power and interconnecting cables removed.
None		
<i>Supplies</i>	<i>Special Environmental Conditions</i>	
Tags, identification, Item 60, Appendix C	None	
<i>Personnel Required</i>	<i>General Safety Instructions</i>	
MOS 63W, Wheel vehicle repairer	None	
<i>References</i>	<i>Level of Maintenance</i>	
None	Direct Support	

a. Removal.

- (1) Remove four nuts (1), screws (2), and tilt warning box (3) from bracket (4).
- (2) Remove four screws (5), washers (6), and board (7).
- (3) Remove four nuts (8), washers (9), screws (10), connector (11), and gasket (12) from tilt warning box (3).

NOTE

Tag and mark wires before removal.

- (4) Remove four pins (13) and wires (14).

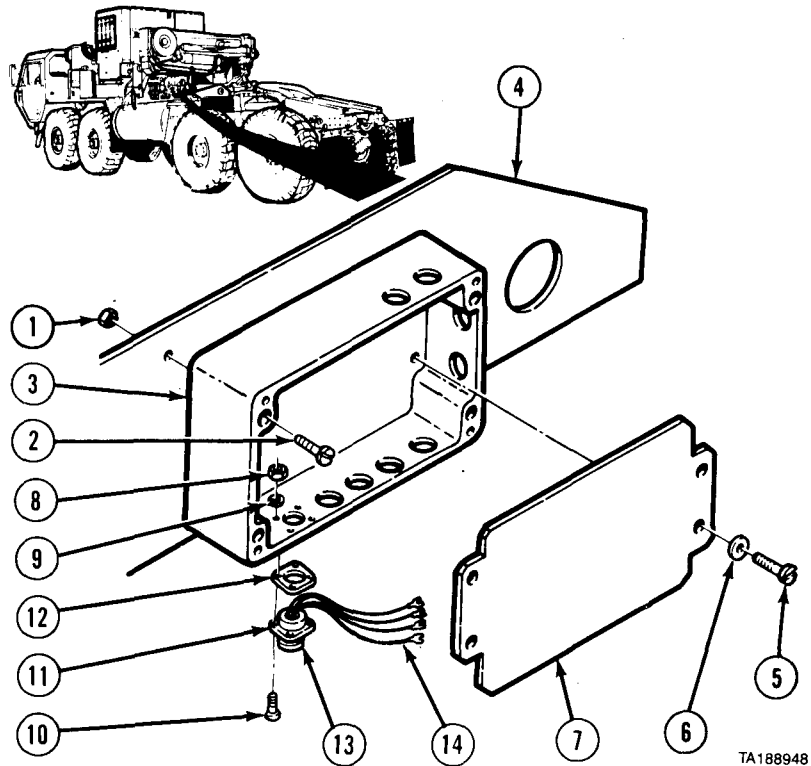

Electrical System Maintenance Instructions (Cont)

b. Cleaning/Inspection.

- (1) Inspect board and metal parts for damage. Replace damaged parts.
- (2) Check wires for damage, loose or broken connections, or damaged insulation. Replace defective wiring or connections.
- (3) Check each wire for continuity. If open circuit or high resistance, replace defective wire.

c. Installation.

- (1) Install four pins (13) and wires (14).
- (2) Install gasket (12) and connector (11) on tilt warning box (3) with four screws (10), washers (9), and nuts (8).
- (3) Install board (7) in tilt warning box (3) with four washers (6) and screws (5).
- (4) Install tilt warning box (3) on bracket (4) with four screws (2) and nuts (1).

d. Follow-on Maintenance.

- (1) Install crane control distribution board (para 6-8).
- (2) Install tilt warning alarm (para 6-7).
- (3) Install power and interconnecting cables (para 6-9).

END OF TASK

6-11. JUNCTION BOX AND CONNECTOR REMOVAL/REPAIR/INSTALLATION (M977, M985).

This task covers:

- | | |
|----------------|--------------------------|
| a. Removal | d. Installation |
| b. Disassembly | e. Follow-on Maintenance |
| c. Assembly | |

INITIAL SETUP

<i>Models</i>	<i>Equipment Condition</i>	
M977, M985	<i>TM or Para</i>	<i>Condition Description</i>
<i>Test Equipment</i>	TM 9-2320-279-10	Shut off engine.
None	Para 6-12	Crane overload sensor switches disconnected.
<i>Special Tools</i>	<i>Special Environmental Conditions</i>	
None	None	
<i>Supplies</i>	<i>General Safety Instructions</i>	
Tags, identification, Item 60, Appendix C	None	
<i>Personnel Required</i>	<i>Level of Maintenance</i>	
MOS 63W, Wheel vehicle repairer	Direct Support	
<i>References</i>		
None		

6-11. JUNCTION BOX AND CONNECTOR REMOVAL/REPAIR/INSTALLATION (M977, M985) (CONT).

a. Removal.

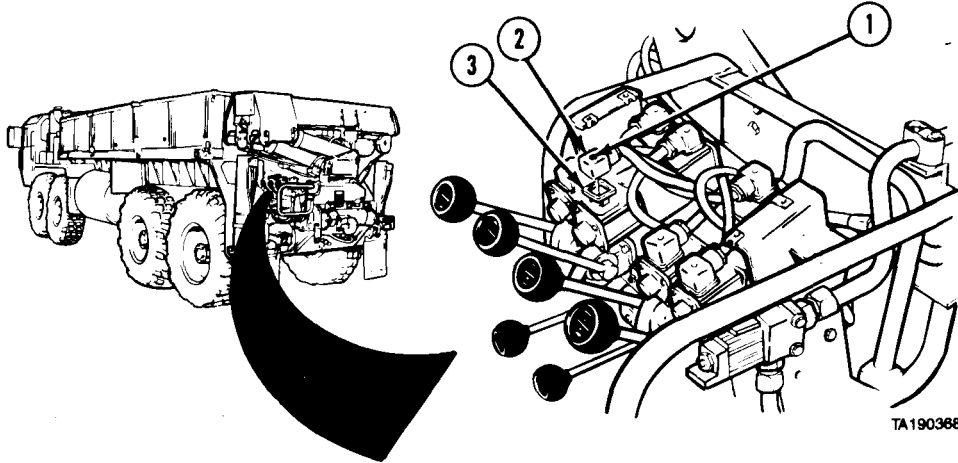

TA190368

NOTE

- M977 crane has 13 connectors.
- M985 crane has 12 connectors.

(1) Loosen 12 screws (1) and remove connectors (2) and seals (3).

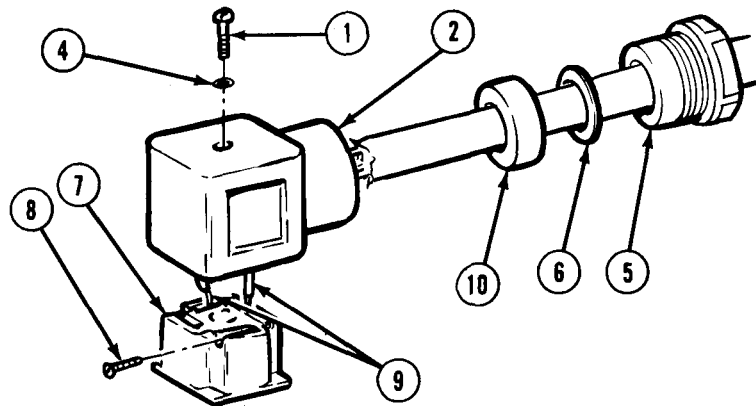

TA190369

- (2) Remove screw (1) and washer (4).
- (3) Remove fitting (5) and washer (6).
- (4) Remove socket (7) from connector (2).
- (5) Remove two screws (8) and wires (9).
- (6) Remove seal (10).

Electrical System Maintenance Instructions (Cont)

- (7) Disconnect cable (11) from junction box (12).

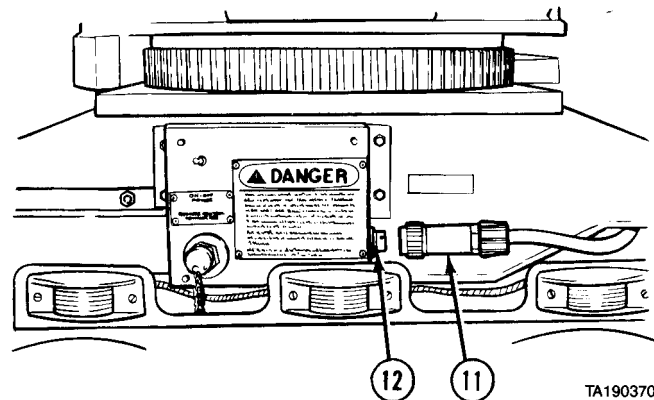

TA190370

- (8) Remove two nuts (13), lockwashers (14), and guard (15).
 (9) Remove four nuts (16), lockwashers (17), and junction box (12).

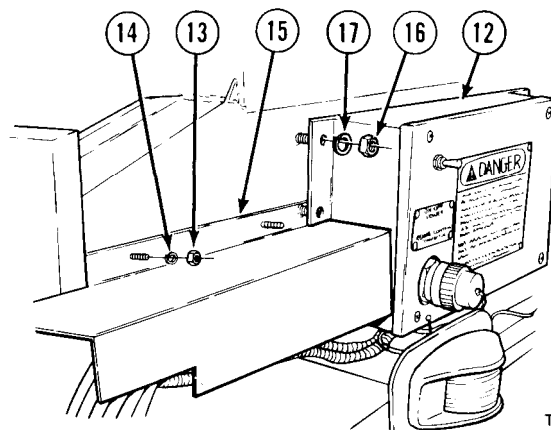

TA190371

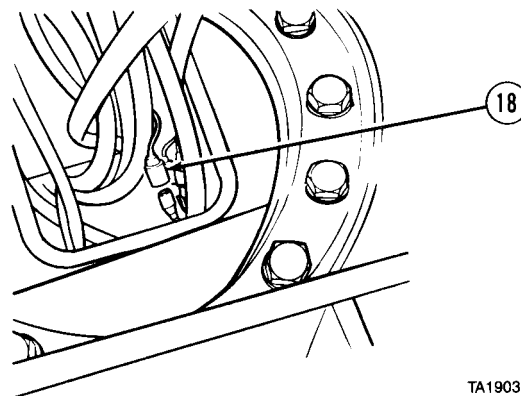
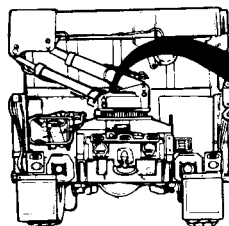

TA190373

NOTE

Tag and mark electrical connectors before disconnecting.

- (10) Disconnect six electrical connectors (18).

Electrical System Maintenance Instructions (Cont)

6-11. JUNCTION BOX AND CONNECTOR REMOVAL/REPAIR/INSTALLATION (M977, M985) (CONT).

b. Disassembly.

- (1) Remove cap (1).
- (2) Remove four screws (2), lockwashers (3), washers (4), and cover (5) from box (6).

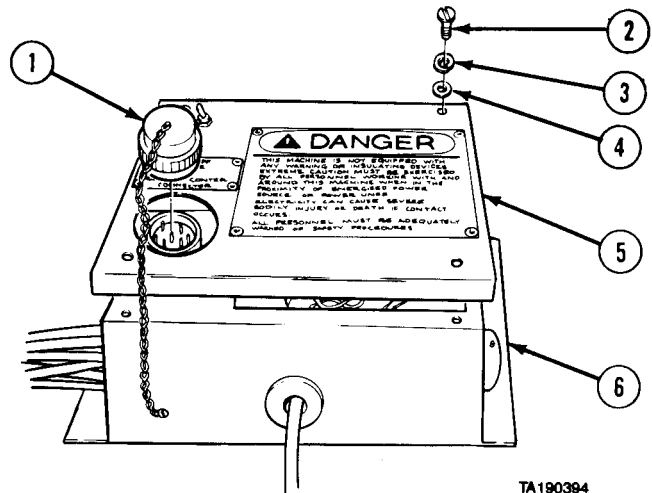

NOTE

Tag and mark wires before removing or disconnecting.

- (3) Remove two screws (7) and three wires (8).
- (4) Remove sealnut (9), lockwasher (10), switch (11), and nut (12).

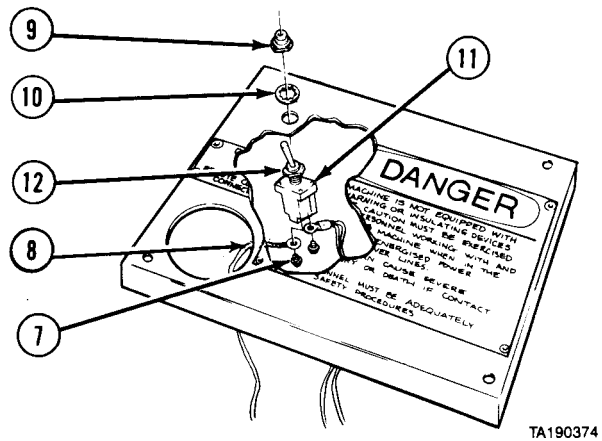

NOTE

Connector must be removed with cable module.

- (5) Remove nut (13) and lockwasher (14).
- (6) Remove nut (15), lockwasher (16), and connector (17).

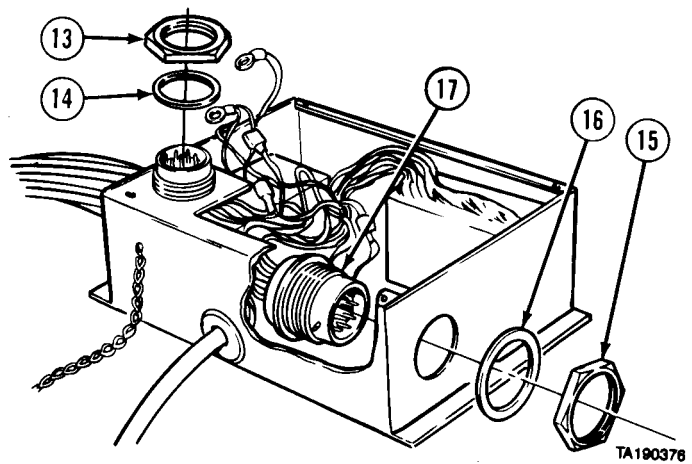

Electrical System Maintenance Instructions (Cont)

- (7) Disconnect eight wires (18).
- (8) Remove two screws (19), lockwasher (20), washers (21), and relay module (22).

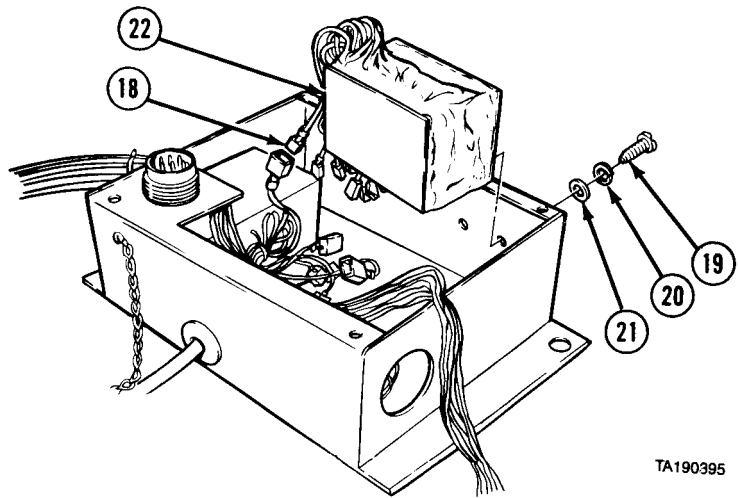

- (9) Remove two screws (23), lockwashers (24), and washers (25).

NOTE

Connector must be removed with cable module.

- (10) Remove cable module (26), connector (17), and cables (27).

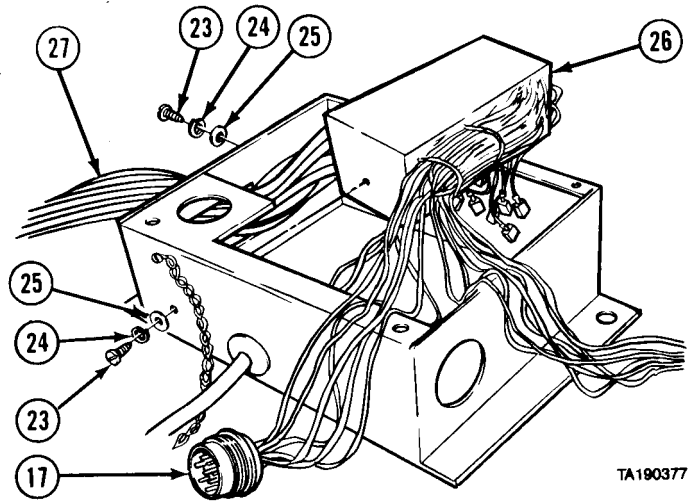

- (11) Remove rubber grommet (28) and wire (29)
- (12) Remove nut (30), screw (31), and chain and cap (32).

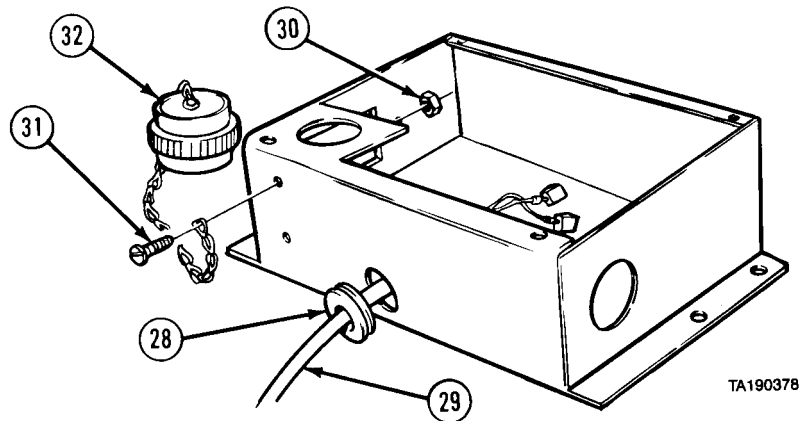

Electrical System Maintenance Instructions (Cont)

6-11. JUNCTION BOX CONNECTOR REMOVAL/REPAIR/INSTALLATION (M977,M985)
(CONT)

- (13) Remove pin (33) from connector (17).
- (14) Remove pin (33) from wire (34).

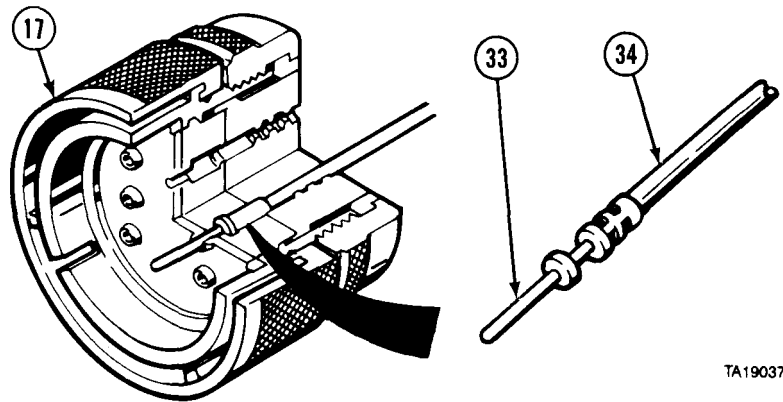

TA190379

c. Assembly.

- (1) Install pin (1) on wire (2).
- (2) Install pin (1) in connector (3).

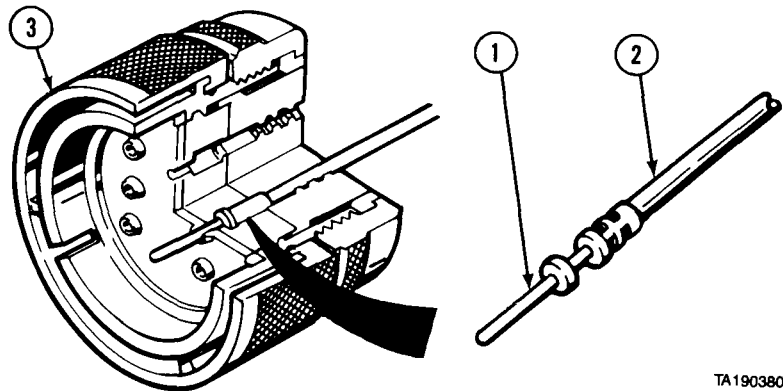

TA190380

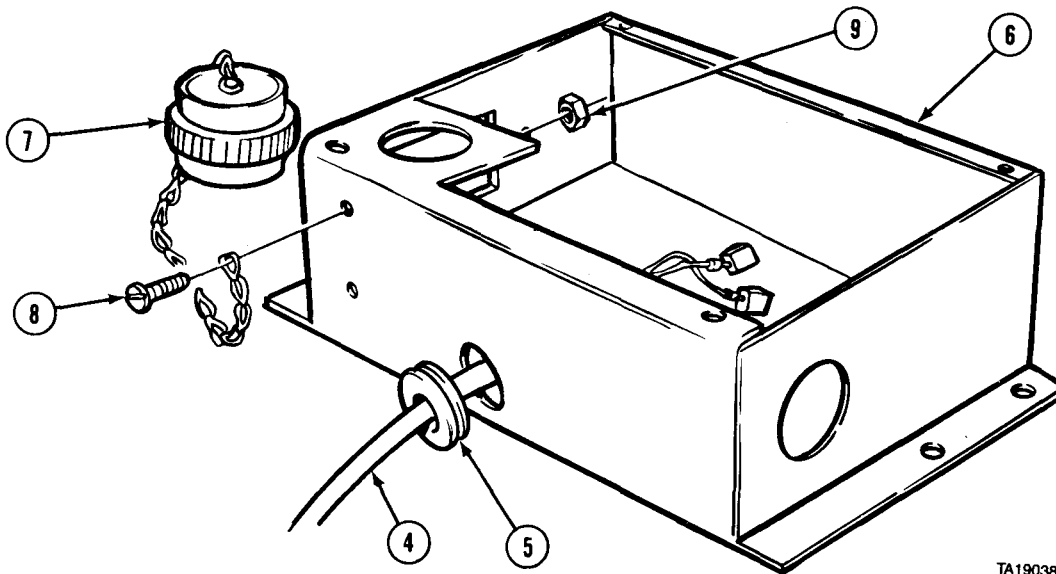

TA190381

- (3) Install wire (4) and grommet (5) in box (6).
- (4) Install cap and chain (7), screw (8), and nut (9).

Electrical System Maintenance Instructions (Cont)

- (5) Install cables (10), connector (3), and cable module (11).
- (6) Install two washers (12), lockwashers (13), and screws (14).

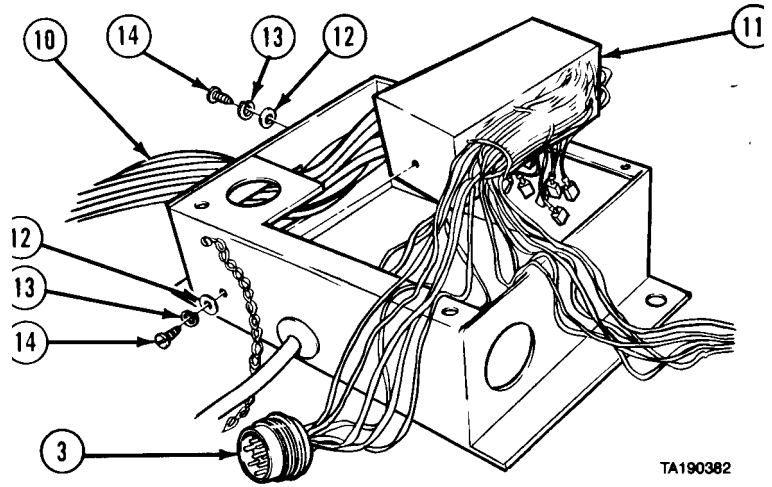

TA190382

- (7) Install relay module (15) with two screws (16), lockwasher (17), and ant washer (18).
- (8) Connect eight wires (19).

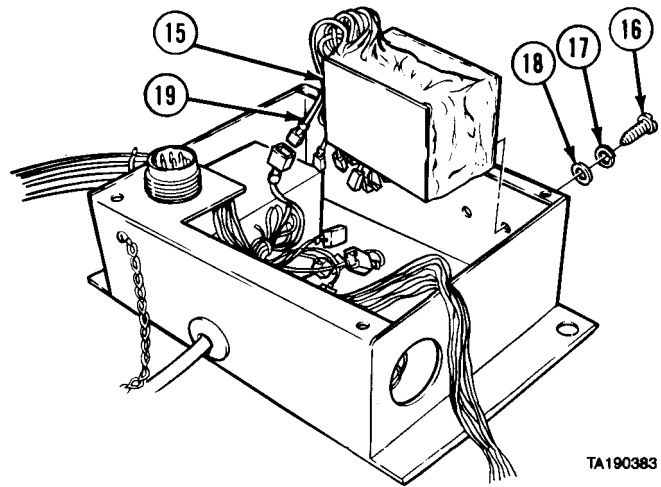

TA190383

- (9) Install connector (3), lockwasher (20), and nut (21).
- (10) Install lockwasher (22) and nut (23).

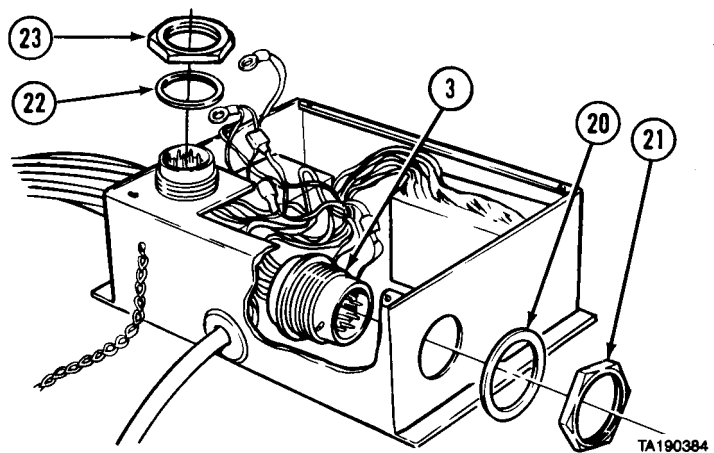

TA190384

Electrical System Maintenance Instructions (Cont)

6-11. JUNCTION BOX AND CONNECTOR REMOVAL/REPAIR/INSTALLATION (M977,M985) (CONT).

- (11) Install nut (24), switch (25), lockwasher (26), and sealnut (27).
- (12) Install three wires (28) with two screws (29).

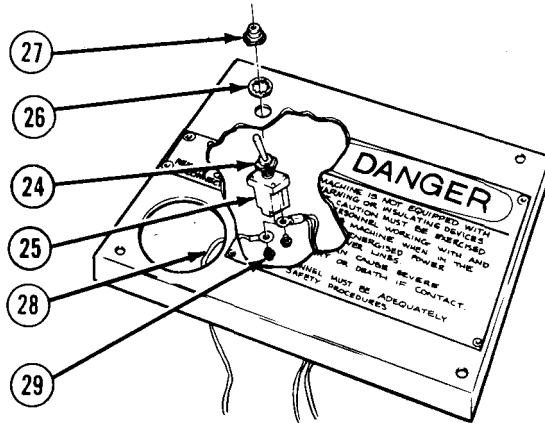

TA190386

- (13) Install cover (30) on box (6) with four washers (31), lockwashers (32), and screws (33).
- (14) Install cap (34).

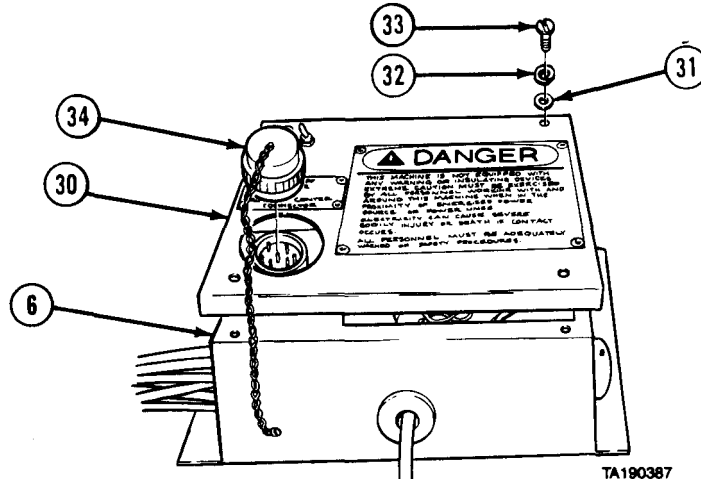

TA190387

d. Installation.

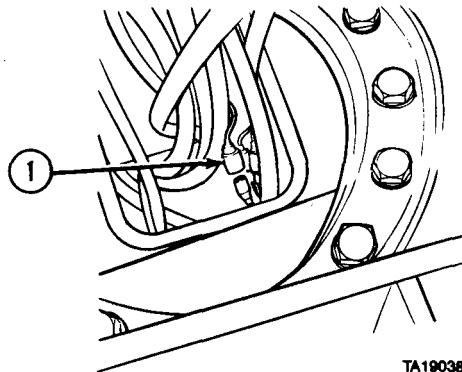

TA190388

- (1) Connect six electrical connectors (1).

Electrical System Maintenance Instructions (Cont)

- (2) Install junction box (2), four lockwashers (3), and nuts (4).
- (3) Install guard (5), two lockwashers (6), and nuts (7).

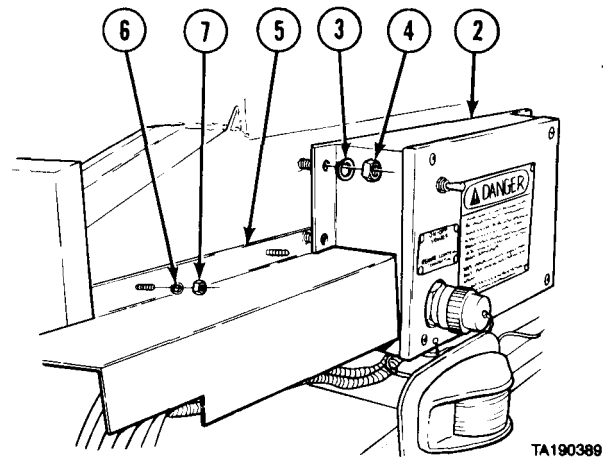

- (4) Connect cable (8) to junction box (2).

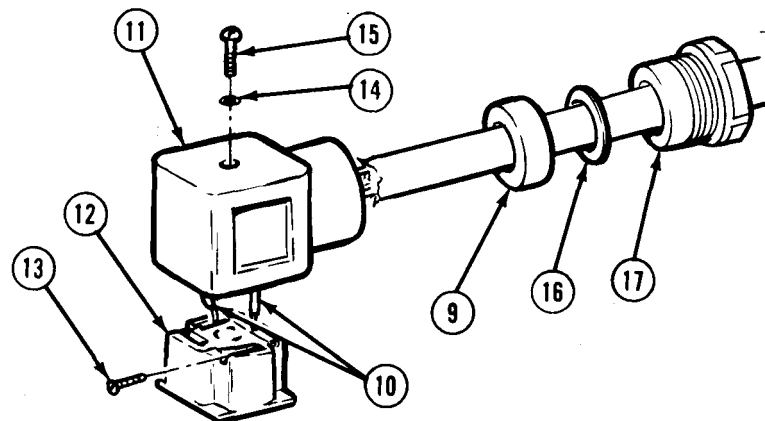
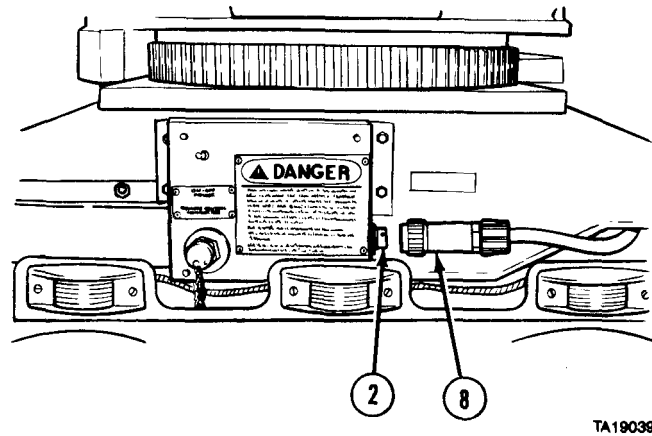

- (5) Install seal (9) and two wires (10) in connector (11).
- (6) Connect two wires (10) to socket (12) with two screws (13).
- (7) Install socket (12) in connector (11).
- (8) Install washer (14) and screw (15).
- (9) Install washer (16) and fitting (17) on connector (11).

Electrical System Maintenance Instructions (Cent)

**6-11. JUNCTION BOX AND CONNECTOR REMOVAL/REPAIR/INSTALLATION (M977, M985)
(CONT).**

N O T E

M977 crane has 13 connectors.
M985 crane has 12 connectors.

- (10) Install 12 seals (18) and connectors (11) on valves (19).
- (11) Tighten 12 screws (15).

e. Follow-on Maintenance. Connect crane overload sensor switches (para 6-12).

END OF TASK

6-11.1. JUNCTION BOX AND CONNECTOR REMOVAL/REPAIR/INSTALLATION (M984E1).

This task covers:

- a. Removal
- b. Disassembly
- c. Assembly
- d. Installation
- e. Follow-on Maintenance

INITIAL SETUP

<i>Models</i>	<i>Equipment Condition</i>	
M984E1	<i>TM or Para</i>	<i>Condition Description</i>
<i>Test Equipment</i>	TM 9-2320-279-20	Batteries disconnected.
None	TM 9-2320-279-20	Left remote control hookup connector removed.
<i>Special Tools</i>	Para 6-12.1	Overload protection switch disconnected.
None	Para 17-28.4	Right hand front control body removed (plugs only).
<i>Supplies</i>	<i>Special Environmental Conditions</i>	
None	None	
<i>Personnel Required</i>	<i>General Safety Instructions</i>	
MOS 63W, Heavy wheel vehicle mechanic	None	
<i>References</i>	<i>Level of Maintenance</i>	
None	Direct Support	

Electrical System Maintenance Instructions (Cont)

a. Removal.

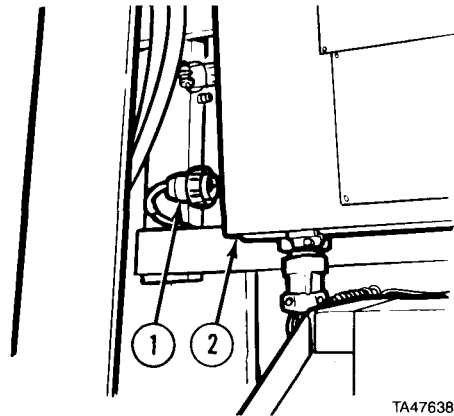
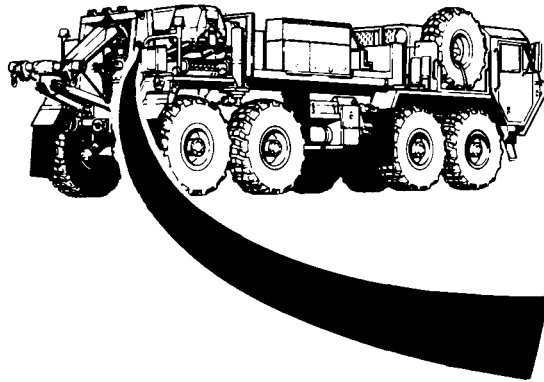

TA476381

(1) Disconnect connector (1) from high idle box (2).

NOTE

Remove all wire ties as necessary.

- (2) Remove two nuts (3), lockwashers (4), flatwashers (5), and screws (6).
- (3) Remove two nuts (7), lockwashers (8), flatwashers (9), screws (10), and front brace (11).
- (4) Remove box (12) from bracket (13).

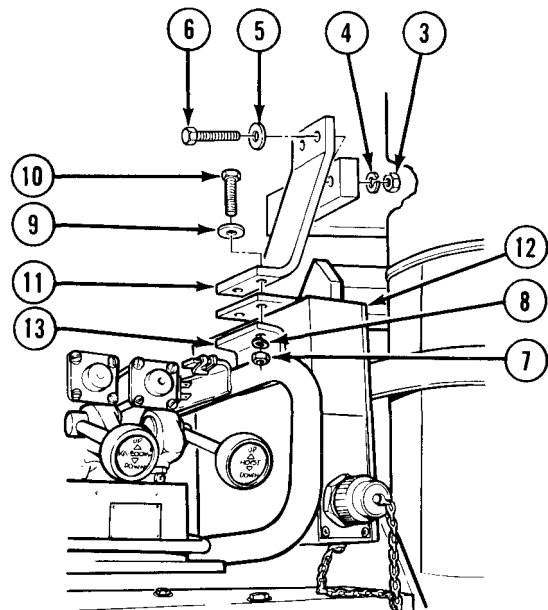

TA476382

b. Disassembly.

NOTE

All 13 plugs are repaired the same.

- (1) Remove screw (1) and washer (2).
- (2) Loosen fitting (3) and slide back fitting, washer (4), and seal (5).
- (3) Remove plug connector (6) from plug (7).
- (4) Remove two screws (8) and wires (9) from plug (7).
- (5) Remove plug (7), seal (5), washer (4), and fitting (3) from harness (10).

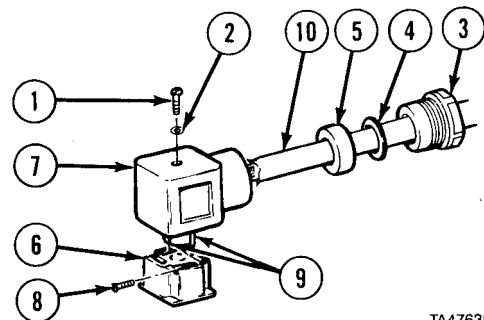

TA476383

Electrical System Maintenance Instructions (Cont)

6-11.1. JUNCTION BOX AND CONNECTOR REMOVAL/REPAIR/INSTALLATION (M984E1)
(CONT).

- (6) Remove two screws (11) and washers (12) from connector (13).

NOTE

All three pins must be removed at the same time.

- (7) Remove three pins (14) from connector (13).
- (8) Remove three pins (14) from wires (15).

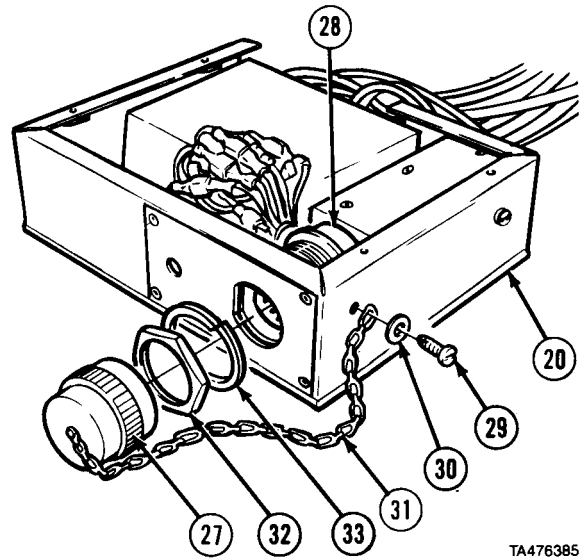
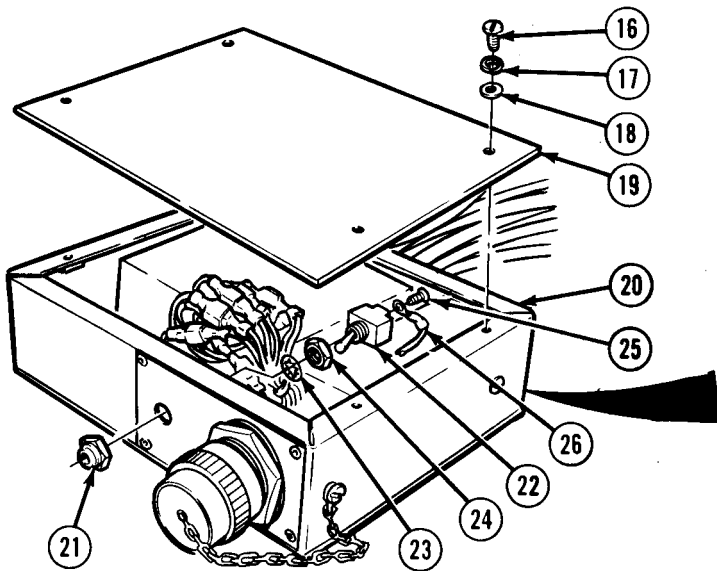
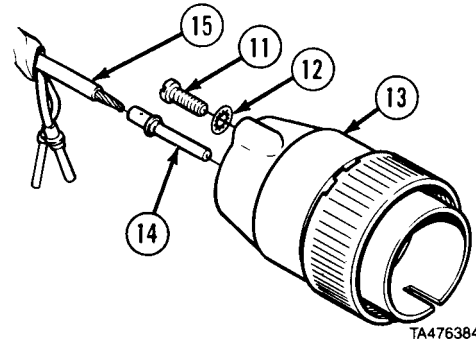

NOTE

Tag and mark all wires.

- (9) Remove four screws (16), lockwashers (17), washers (18), and cover (19) from box (20).
- (10) Remove seal nut (21), switch (22), lockwasher (23), and nut (24).
- (11) Remove two screws (25) and wire (26) from switch (22).
- (12) Remove cap (27) from connector (28).
- (13) Remove screw (29), washer (30), and chain (31) from box (20).
- (14) Remove nut (32) and lockwasher (33).

Electrical System Maintenance Instructions (Cont)

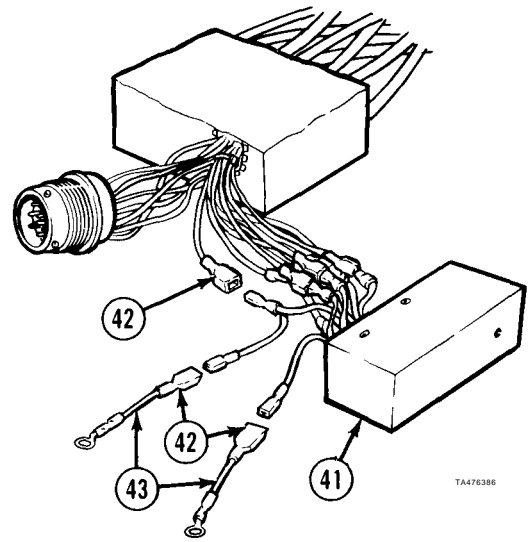
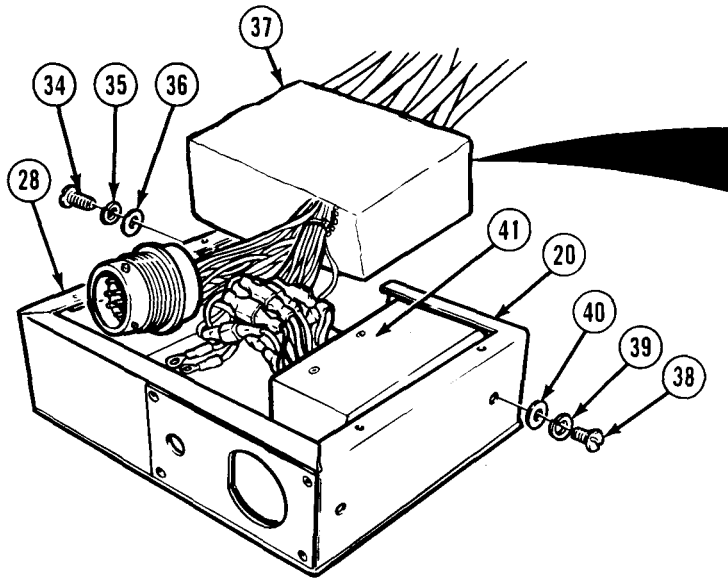

TA476386

- (15) Remove four screws (34), lockwasher (35), and washers (36) from cable module (37).
- (16) Remove two screws (38), lockwashers (39), and washers (40) from relay module (41).
- (17) Remove cable module (37), relay module (41), and connector (28) from box (20).
- (18) Disconnect seven connectors (42).
- (19) Remove relay module (41), disconnect two connectors (42) and remove two wires (43).

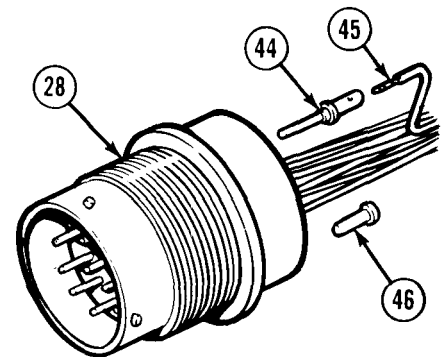
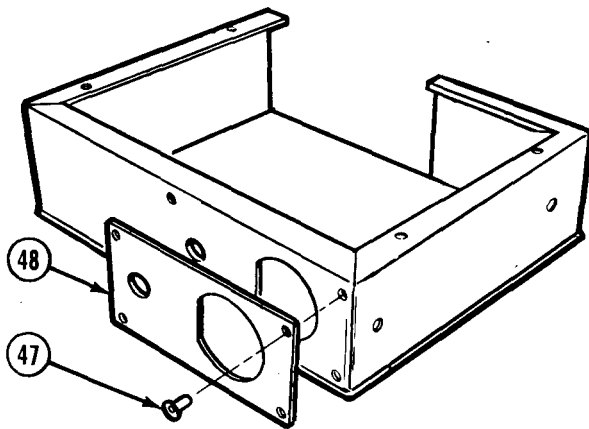

TA476387

NOTE

Tag and mark all wires.

- (20) Remove 11 pins (44) from connector (28).
- (21) Remove 11 pins (44) from wires (45).
- (22) Remove three plugs (46).
- (23) Remove four rivets (47) and tag (48).

Electrical System Maintenance Instructions (Cent)

6-11.1. JUNCTION BOX AND CONNECTOR REMOVAL/REPAIR/INSTALLATION (M984E1)

c. Assembly.

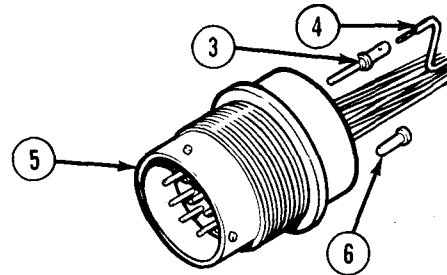
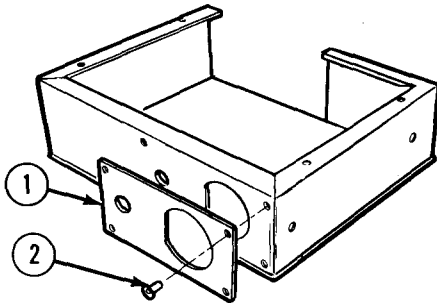

TA476388

- (1) Install tag (1) with four rivets (2).
- (2) Install 11 pins (3) on wires (4).
- (3) Install 11 pins (3) in connector (5) and three plugs (6).

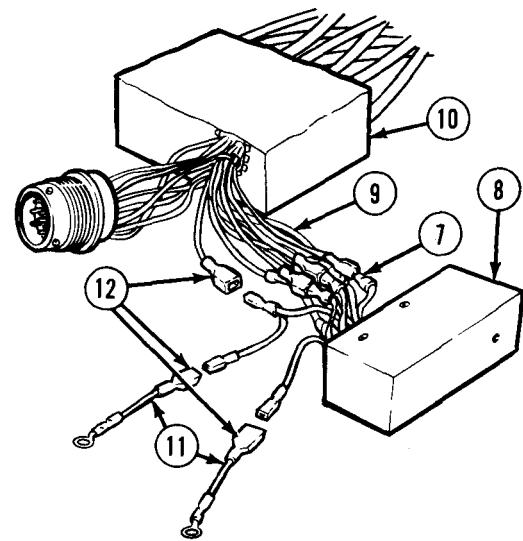
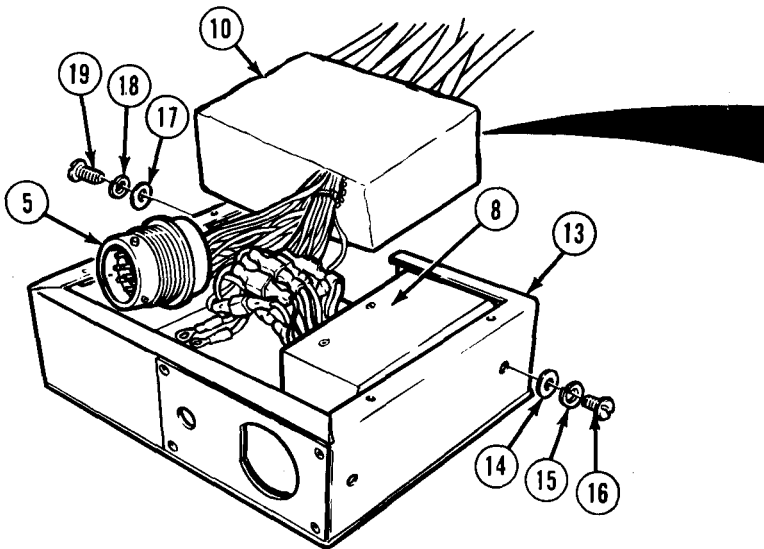

TA476389

- (4) Connect seven wires (7) from relay module (8) to seven wires (9) from cable module (10) and two wires (11) with nine connectors (12).
- (5) Position relay module (8), cable module (10), and connector (5) in box (13).
- (6) Install two washers (14), lockwashers (15), and screws (16) in relay module (8).
- (7) Install four washers (17), lockwashers (18), and screws (19) in cable module (10).

Electrical System Maintenance Instructions (Cont)

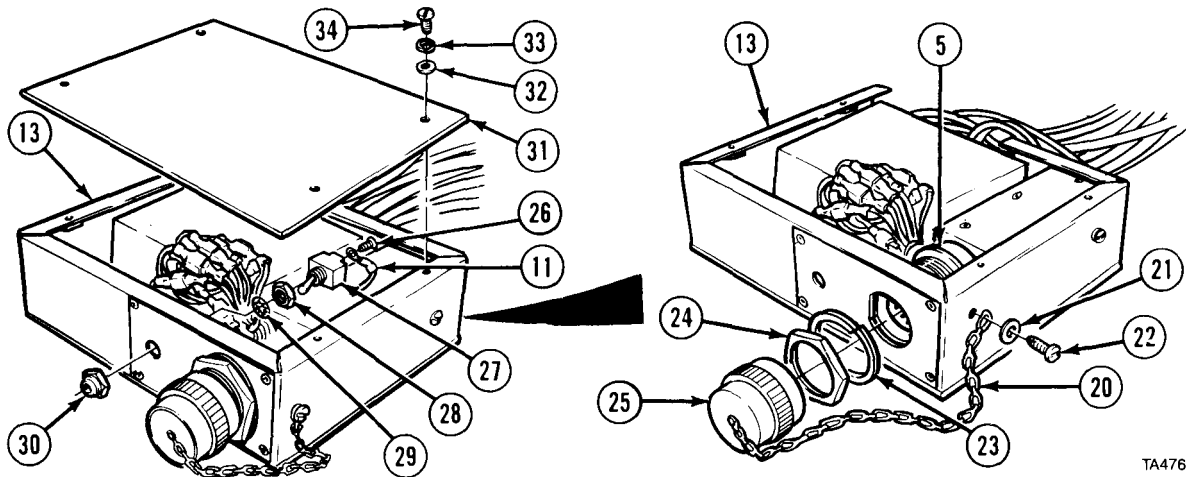

TA476390

- (8) Install chain (20) with washer (21) and screw (22).
- (9) Install connector (5) in box (13) with lockwasher (23) and nut (24).
- (10) Install cap (25) on connector (5).
- (11) Connect two wires (11) with screws (26) to switch (27).
- (12) Install nut (28) and lockwasher (29) on switch (27).
- (13) Install switch (27) in box (13) with seal nut (30).
- (14) Install cover (31) with four washers (32), lockwashers (33), and screws (34).

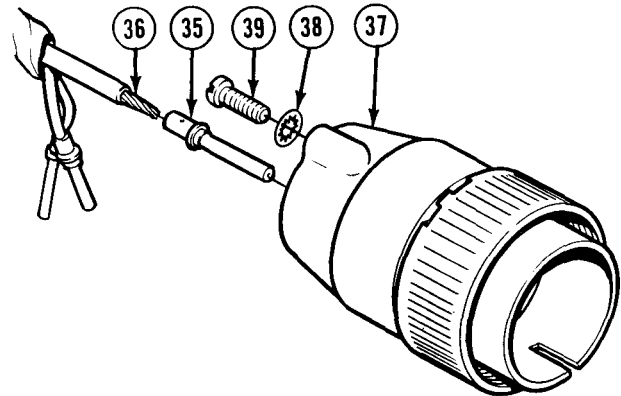
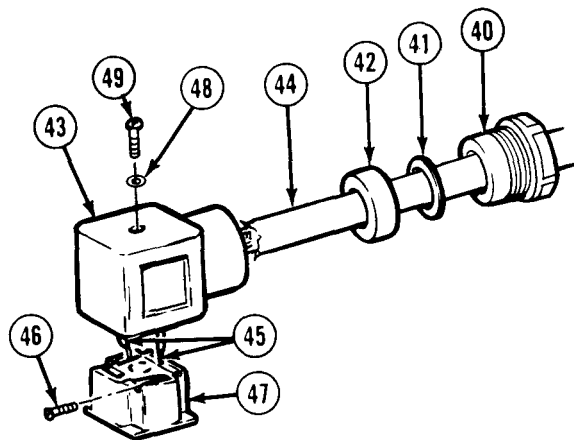

TA476391

- (15) Install three pins (35) on wires (36).
- (16) Install three pins (35) in connector (37).
- (17) Install two washers (38) and screws (39).
- (18) Install fitting (40), washer (41), seal (42), and plug (43) on harness (44).
- (19) Install two wires (45) with screws (46).
- (20) Install plug connector (47) in plug (43) with washer (48) and screw (49).
- (21) Install seal (42), washer (41), and fitting (40) in plug (43).

Electrical System Maintenance Instructions (Cont)

6-11.1. JUNCTION BOX AND CONNECTOR REMOVAL/REPAIR/INSTALLATION (M984E1) (CONT).

d. Installation.

- (1) Install box (1) to bracket (2).
- (2) Install brace (3) with two screws (4), flatwashers (5), lockwashers (6), and nut (7). Do not tighten.
- (3) Install two screws (8), flatwashers (9), lockwashers (10), and nuts (11).
- (4) Tighten nuts (7 and 11).
- (5) Connect connector (3) to high idle box (4).

e. Follow-on Maintenance.

- (1) Right hand front control body plugs installed (para 17-28.4).
- (2) Overload protection switches connected (para 6-12.1).
- (3) Left hand remote control connector installed (TM 9-2320-279-20).
- (4) Batteries connected (TM 9-2320-279-20).

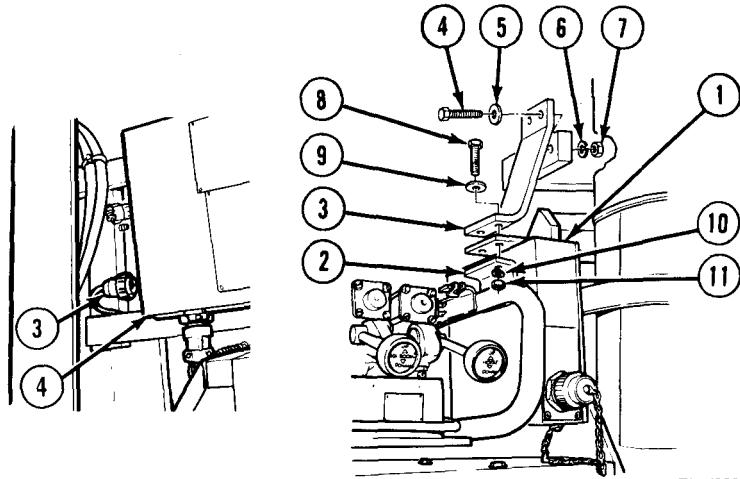

TA476392

END OF TASK

6-12. CRANE OVERLOAD SENSOR SWITCHES REMOVAL/INSTALLATION (M977, M985).

This task covers:

- a. Main Overload Switch Removal
- b. Main Overload Switch Installation
- c. Reduced Overload Switch Removal (M977 only)
- d. Reduced Overload Switch Installation (M977 only)
- e. Mast Overload Switch Removal (M977 only)
- f. Mast Overload Switch Installation (M977 only)
- g. Follow-on Maintenance

INITIAL SETUP

Models	<i>Equipment Condition</i>
M977, M985	<i>TM or Para</i> <i>Condition Description</i>
Test Equipment	TM 9-2320-279-10 Prepare crane for use.
None	TM 9-2320-279-10 Boom raised approximately 1 ft (30 cm).
Special Tools	<i>Special Environmental Conditions</i>
None	None
Supplies	<i>General Safety Instructions</i>
Tags, identification, Item 60, Appendix C	None
Ties, cable, plastic, Item 65, Appendix C	<i>Level of Maintenance</i>
Personnel Required	Direct Support
MOS 63W, Wheel vehicle repairer	
References	
None	

Electrical System Maintenance Instructions (Cont)

a. Main Overload Switch Removal.

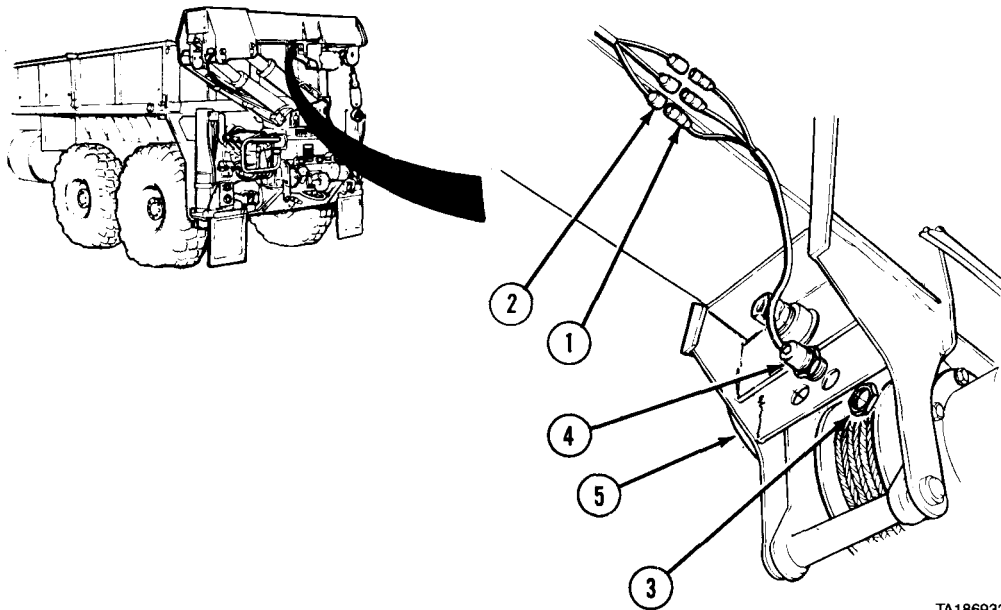

TA186932

NOTE

- Main overload switch is the same for M977 and M985.
- Tag and mark wires before removal.

- (1) Disconnect three wires (1) at connectors (2).
- (2) Remove nut (3) and main overload switch (4) from mounting bracket (5).

b. Main Overload Switch Installation.

NOTE

Main overload switch is the same for M977 and M985.

- (1) Install main overload switch (1) on mounting bracket (2) with nut (3).
- (2) Connect three wires (4) to connectors (5) (fig. 6-1).

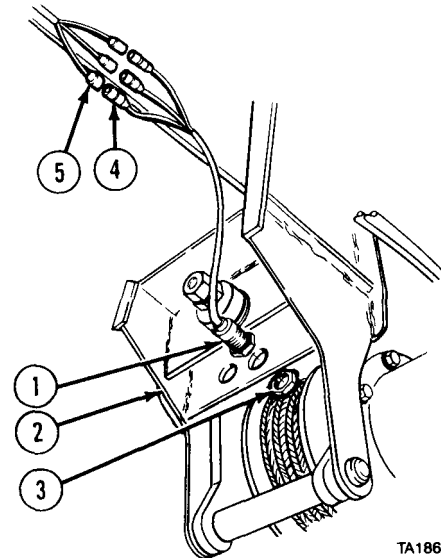

TA186927

Electrical System Maintenance Instructions (Cont)

6-12. CRANE OVERLOAD SENSOR SWITCHES REMOVAL/INSTALLATION (M977, M985)
(CONT).

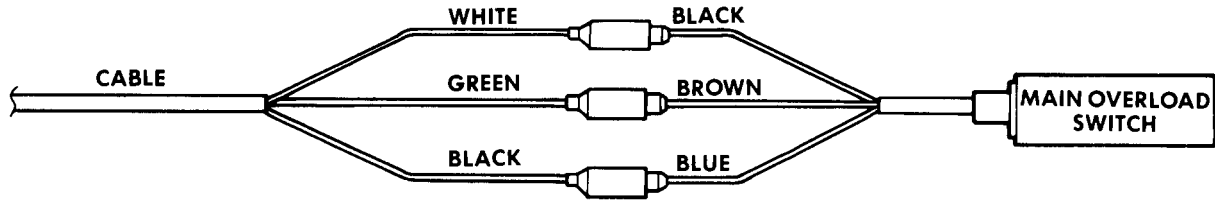

TA186935

Figure 6-1. Main Overload Switch Wiring.

- (3) Tighten nut (6) and jamnut (7) until one screw thread is below surface of nut (6).
- (4) Adjust nut (8) and jamnut (9) until main overload switch (1) is 1/4 in. (6 mm) from switch sensing plate (10),

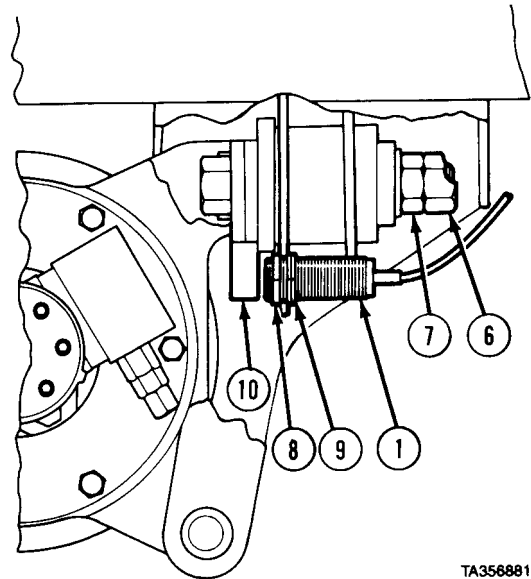

TA356881

c. Reduced Overload Switch Removal (M977 only).

NOTE

Tag and mark wires before removal.

- (1) Disconnect three wires (1) at connectors (2).

NOTE

Remove clips and plastic cable ties.

- (2) Remove nut (3) and overload switch (4) from mounting bracket (5).

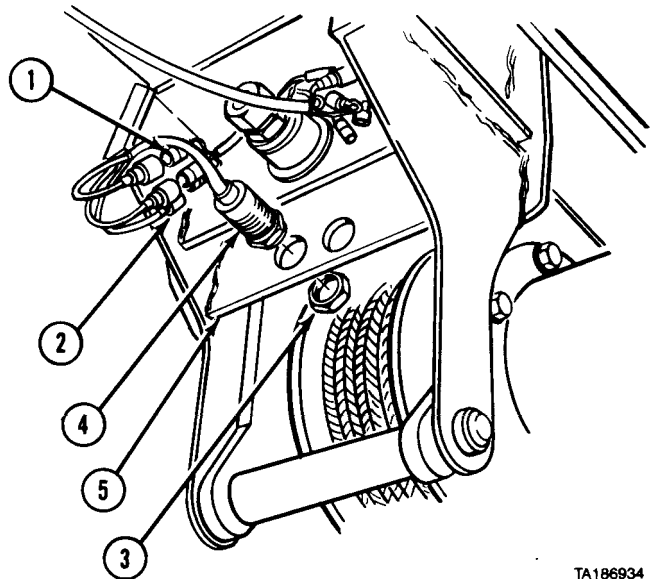

TA186934

Electrical System Maintenance Instructions (Cont)

d. Reduced Overload Switch Installation (M977 only).

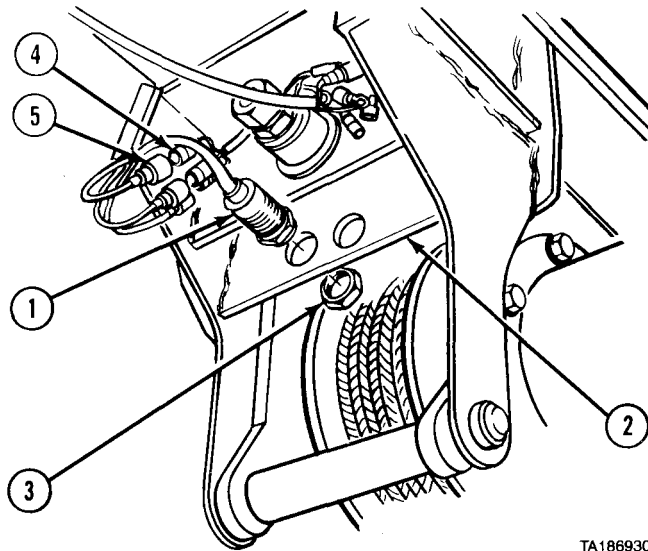

TA186930

- (1) Install reduced overload switch (1) on mounting bracket (2) with nut (3).
- (2) Connect three wires (4) to connectors (5) (fig. 6-2).

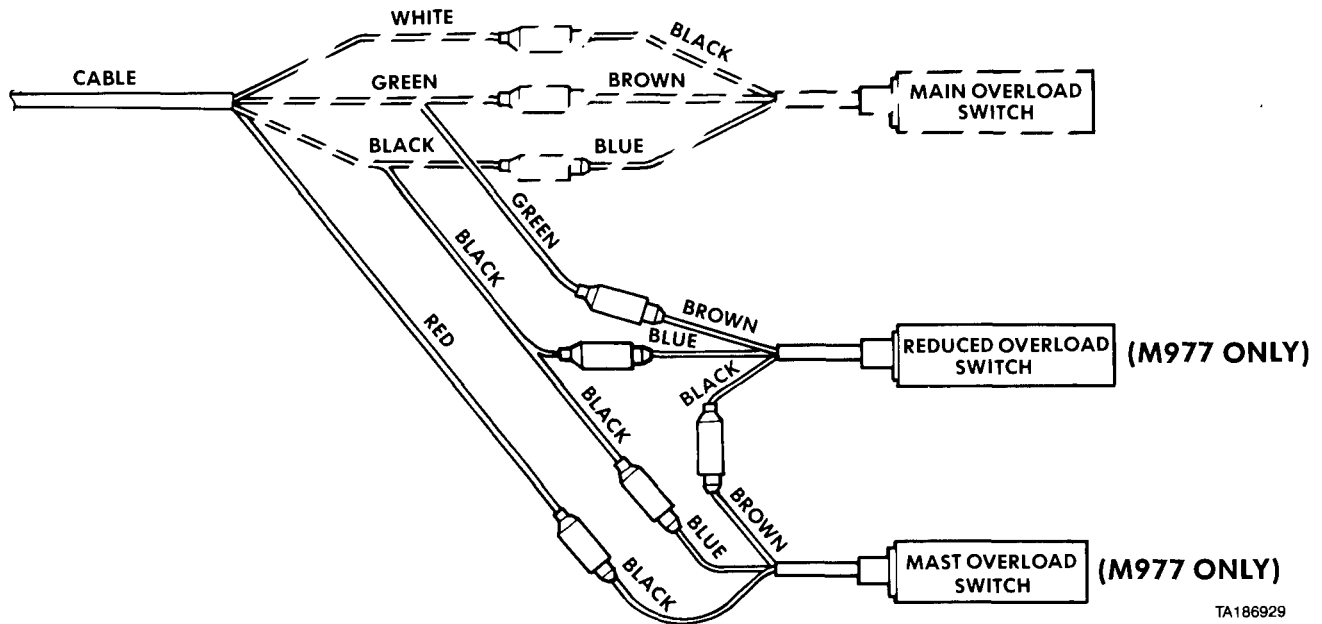

TA186929

Figure 6-2. Reduced Overload and Mast Overload Switch Wiring.

Electrical System Maintenance Instructions (Cent)

6-12. CRANE OVERLOAD SENSOR SWITCHES REMOVAL/INSTALLATION (M977, M985)

- (3) Tighten nut (6) and jamnut (7) until one screw thread is below surface of nut (6).
- (4) Adjust nut (8) and jamnut (9) until reduced overload switch (1) is 1/4 in. (6 mm) from switch sensing plate (10).

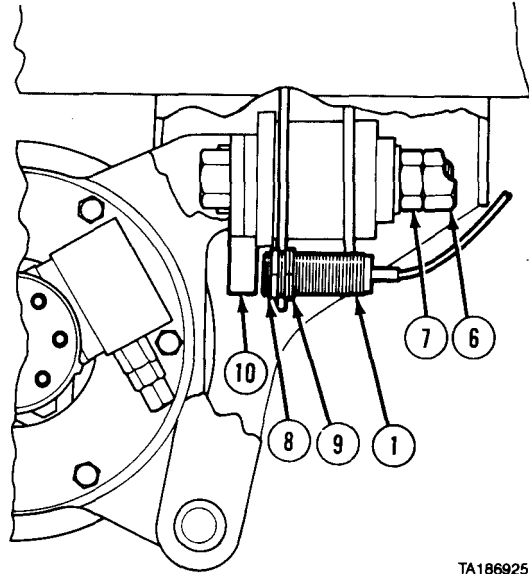

TA186925

e. Mast Overload Switch Removal (M977 only).

NOTE

Tag and mark wires before removal.

- (1) Disconnect three wires (1) at connectors (2).

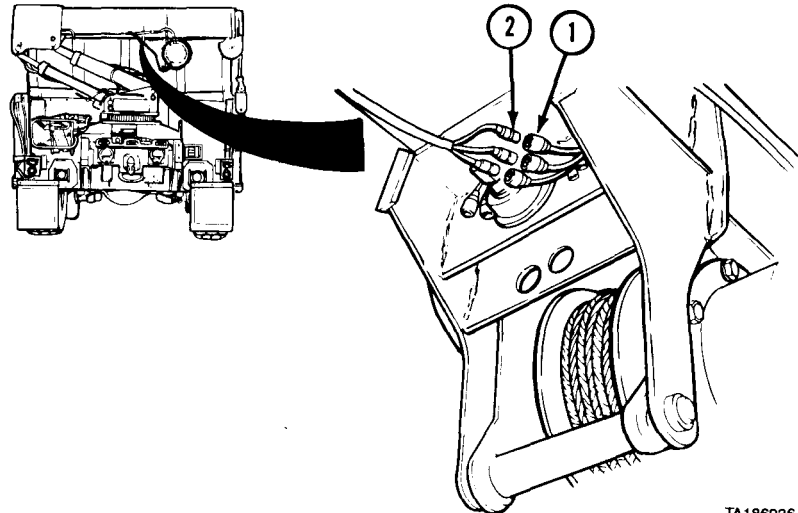

TA186936

NOTE

Remove clips and plastic cable ties.

- (2) Remove four screws (3) and mounting clamp (4) from mast (5).
- (3) Remove mast overload switch (6) from mounting clamp (4).

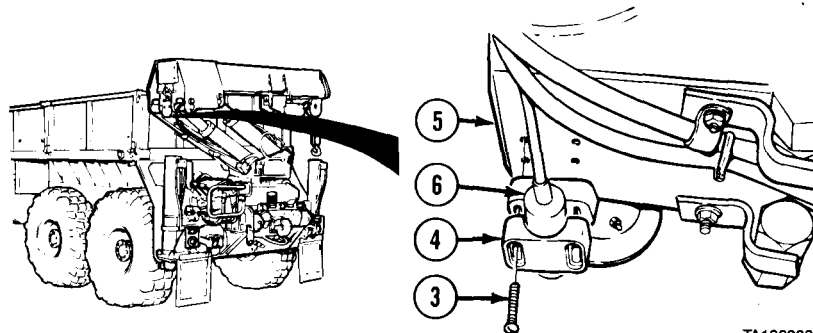

TA186933

Electrical System Maintenance Instructions (Cont)

f. Mast Overload Switch Installation (M977 only).

- (1) Install mast overload switch (1) in mounting clamp (2).
- (2) Install mounting clamp (2) on mast (3) with four screws (4).

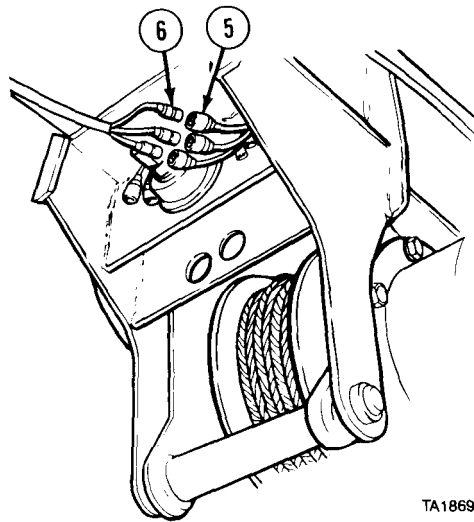
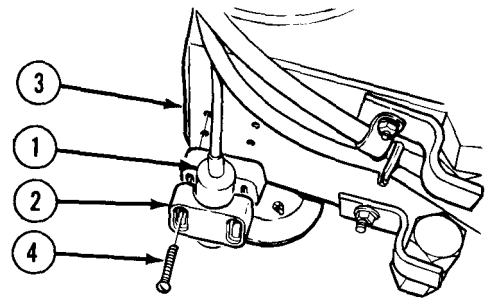

TA186928

- (3) Connect three wires (5) to connectors (6) (fig. 6-2).

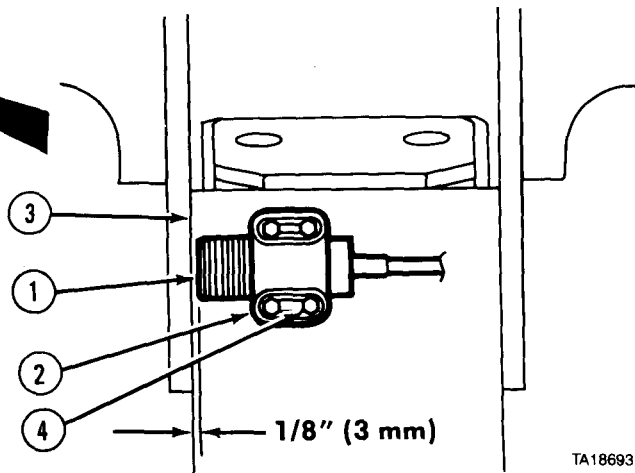
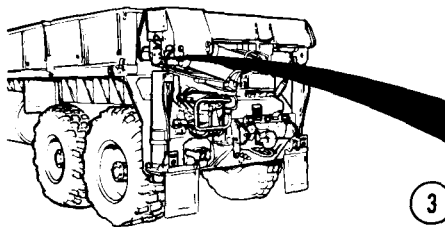

TA186931

- (4) Loosen four screws (4) and adjust mounting clamp (2) so mast overload switch (1) is 1/8 in. (3 mm) from edge of mast (3). Tighten screws.

g. follow-on Maintenance. Adjust overload sensor switches (para 17-33).

END OF TASK

Electrical System Maintenance Instructions (Cont)

6-12.1. CRANE OVERLOAD SENSOR SWITCHES AND PLATE AND TERMINAL BOX REMOVAL/INSTALLATION (M984E1).	
This task covers:	
a. Removal b. Installation	c. Follow-on Maintenance
INITIAL SETUP	
<i>Models</i> M984E1	<i>Equipment Condition</i>
<i>Test Equipment</i> None	<i>TM or Para</i> <i>Condition Description</i> TM 9-2320-279-10 Crane in operating condition. TM 9-2320-279-10 Position crane for access.
<i>Special Tools</i> None	<i>Special Environmental Conditions</i> None
<i>Supplies</i> None	<i>General Safety Instructions</i> None
<i>Personnel Required</i> MOS 63W, Heavy wheel vehicle repairer	<i>Level of Maintenance</i> Direct Support
<i>References</i> None	

a. Removal.

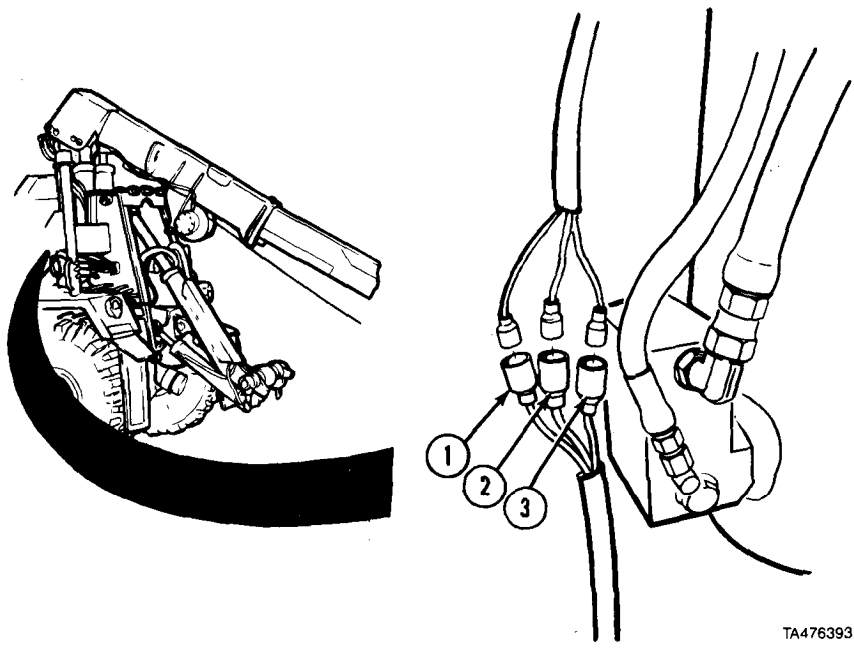

TA476393

NOTE

Remove wire clips and ties as necessary. Tag and mark all wires.

(1) Disconnect three connectors (1), (2), and (3).

Electrical System Maintenance Instructions (Cont)

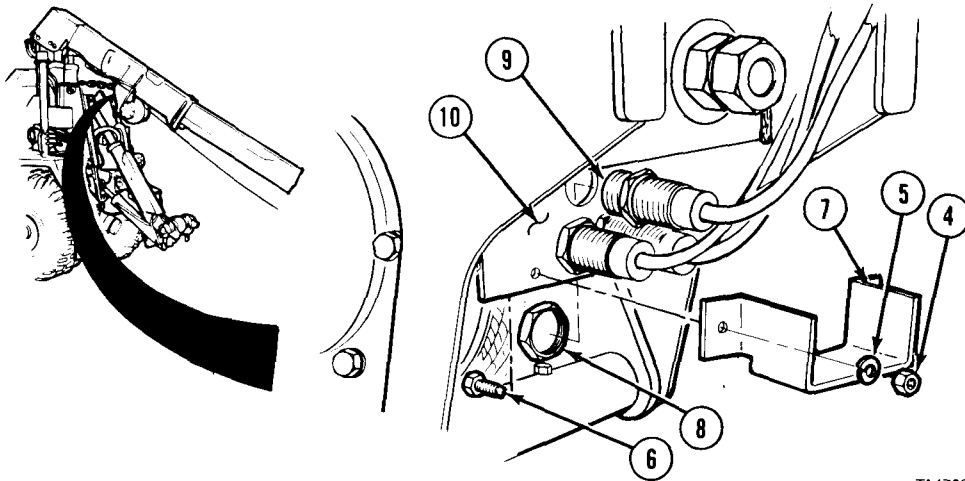

TA476394

(2) Remove two nuts (4), lockwashers (5), screws (6), and bracket (7).

NOTE

- All four overload switches are removed the same way.
- Tag and mark overload switches before removing.

(3) Remove nut (8) and overload switch (9) from mounting bracket (10).

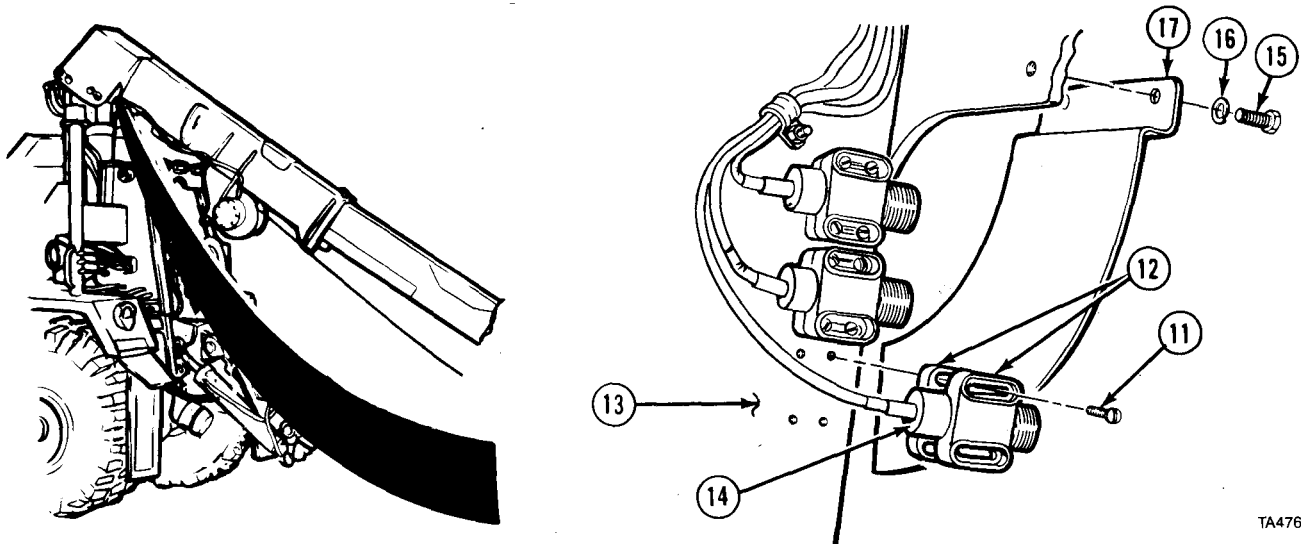

TA476395

NOTE

- The three overload switches are removed the same way.
- Remove clamp, wire ties and clips as necessary.
- Tag and mark overload switches before removing.

(4) Remove four screws (11) and mounting flange (12) from mast (13).

(5) Remove overload switch (14) from mounting flange (12).

(6) Remove two screws (15), lockwashers (16), and sensor plate (17).

Electrical System Maintenance Instructions (Cont)

6-12.1. CRANE OVERLOAD SENSOR SWITCHES AND PLATE AND TERMINAL BOX REMOVAL/INSTALLATION (M984E1) (CONT).

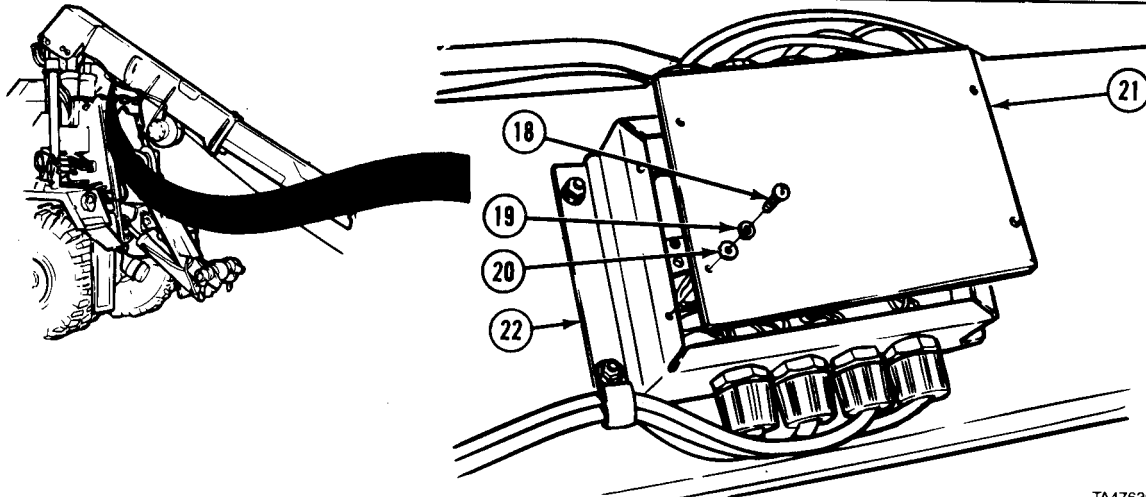

TA476396

(7) Remove four screws (18), lockwashers (19), washers (20), and cover (21) from box (22).

NOTE

- Wires for seven overload switches are removed the same way.
- Remove wire clips and ties as necessary.

(8) Remove connector (23), spacer (24), and grommet (25) from fitting (26).

NOTE

Tag and mark wires before removing.

(9) Loosen three screws (27) on terminal board (28) and remove wires (29).

(10) Remove connector (23), spacer (24), and grommet (25) from wire harness (30).

(11) Remove four nuts (31), lockwashers (32), clamp (33), and box (22).

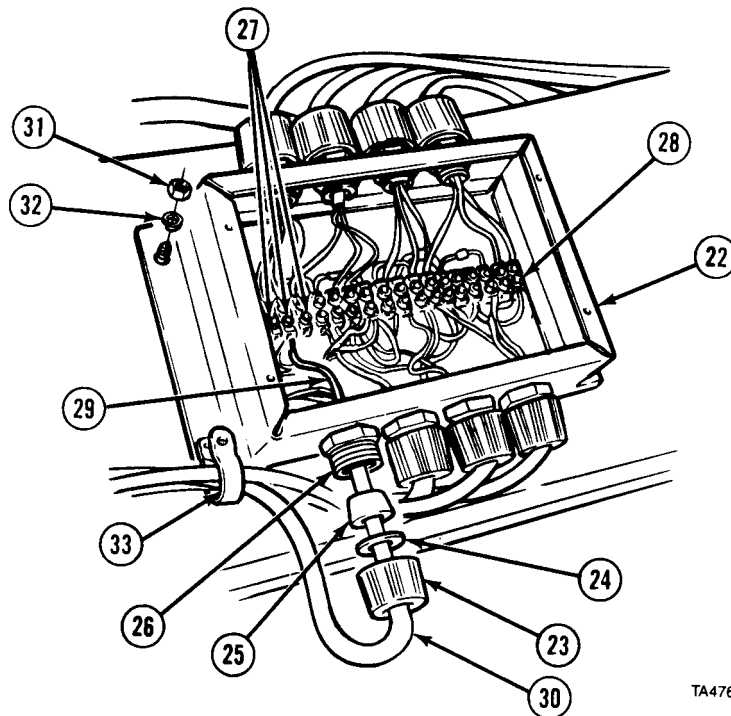

TA476397

Electrical System Maintenance Instructions (Cont)

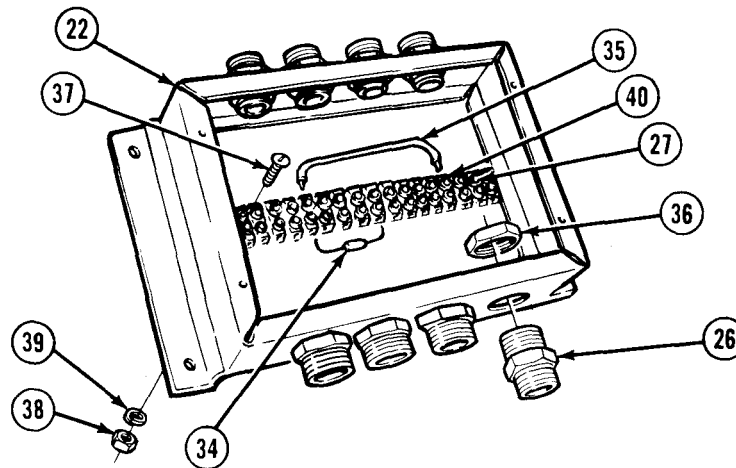

TA476398

- (12) Loosen six screws (27) and remove four rectifiers (34).
- (13) Loosen six screws (27) and remove seven jumper wires (35).
- (14) Remove eight nuts (36) and fittings (26).
- (15) Remove four screws (37), nuts (38), and lockwashers (39).
- (16) Remove two strips (40) from box (22).

b. Installation.

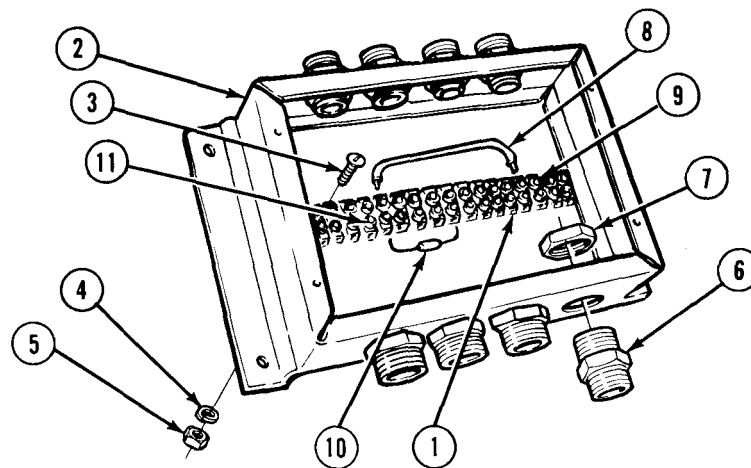

TA476399

- (1) Install two strips (1) in box (2).
- (2) Install four screws (3), lockwashers (4), and nuts (5).
- (3) Install eight fittings (6) and nuts (7).
- (4) Install seven jumper wires (8).
- (5) Tighten six screws (9).
- (6) Install four rectifiers (10) and tighten six screws (11).

Electrical System Maintenance Instructions (Cont)

6-12.1. CRANE OVERLOAD SENSOR SWITCHES AND PLATE AND TERMINAL BOX
REMOVAL/INSTALLATION (M984E1) (CONT).

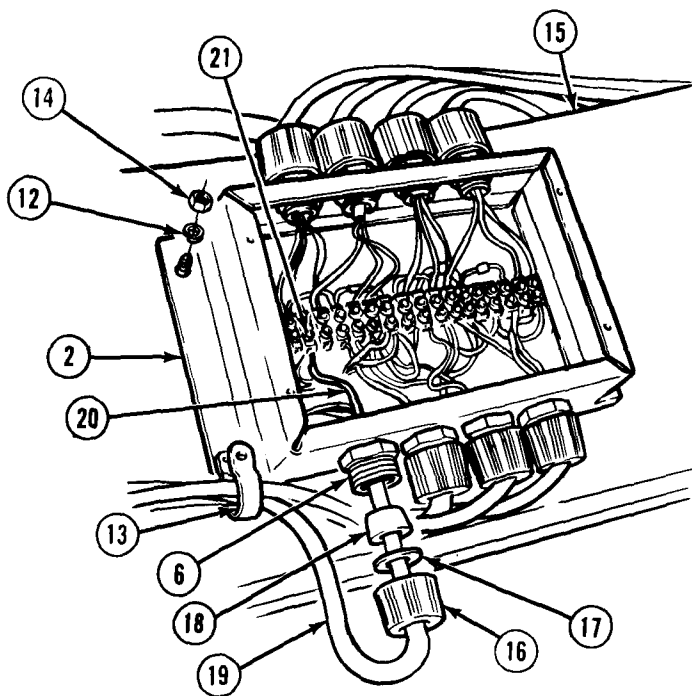

TA476400

- (7) Install box (2) with four lockwashers (12), clamp (13), and nuts (14) to boom (15).
- (8) Install eight connectors (16), spacers (17), and grommet (18) on harness (19).
- (9) Install eight connectors (16) to fittings (6).
- (10) Install 24 wires (20).
- (11) Tighten 22 screws (21).

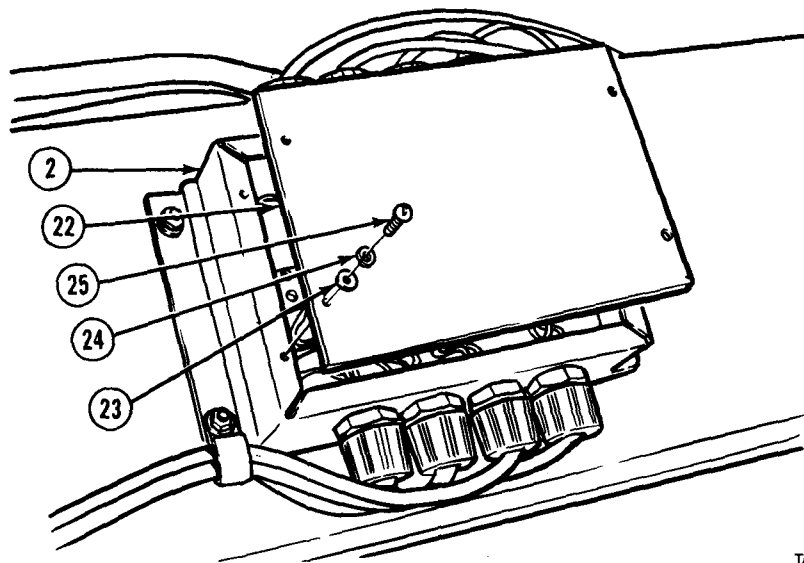

TA476401

- (12) Install cover (22) on box (2) with four washers (23), lockwashers (24), and screws (25).

Electrical System Maintenance Instructions (Cont)

- (13) Install sensor plate (26) with two screws (27) and lockwashers (28).

NOTE

The three overload switches are installed the same way.

- (14) Install mast overload switch (29) in mounting flange (30).
- (15) Install mounting flange (30) on mast (31) with four screws (32).

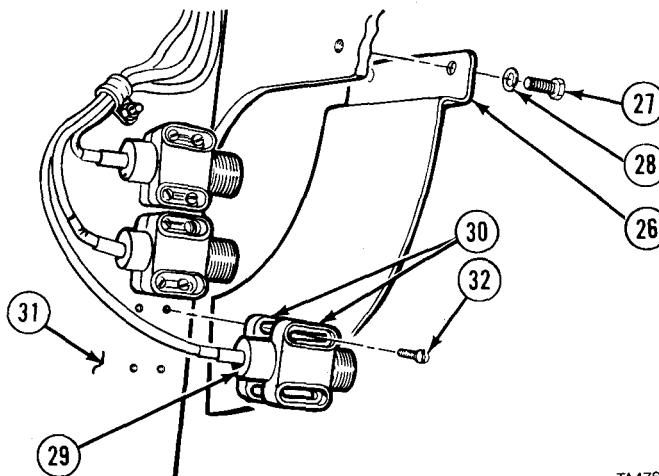

TA476402

NOTE

The four overload switches are installed the same way.

- (16) Install overload switch (33) on mounting bracket (34) with nut (35).

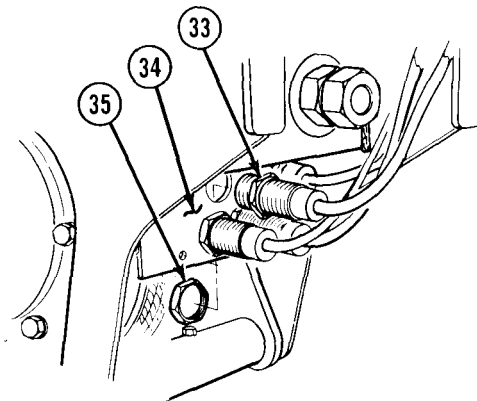

TA476403

NOTE

Settings are made the same way for all four overload switches.

- (17) Tighten nut (36) and jamnut (37) until one screw thread is below surface of nut (36).
- (18) Adjust nut (35) and jamnut (38) until overload switch (33) is 1/16 in. (1.59 mm) from switch sensing plate (39).

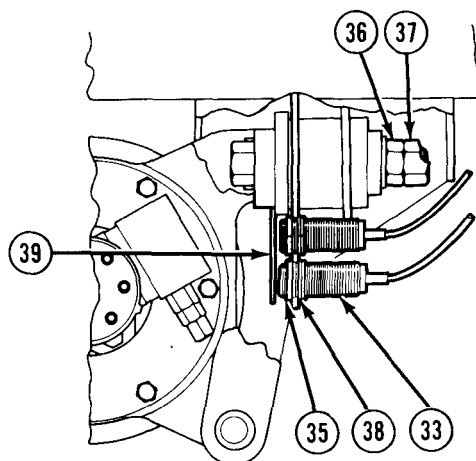

TA476404

Electrical System Maintenance Instructions (Cont)

6-12.1. CRANE OVERLOAD SENSOR SWITCHES AND PLATE AND TERMINAL BOX
REMOVAL/INSTALLATION (M984E1) (CONT).

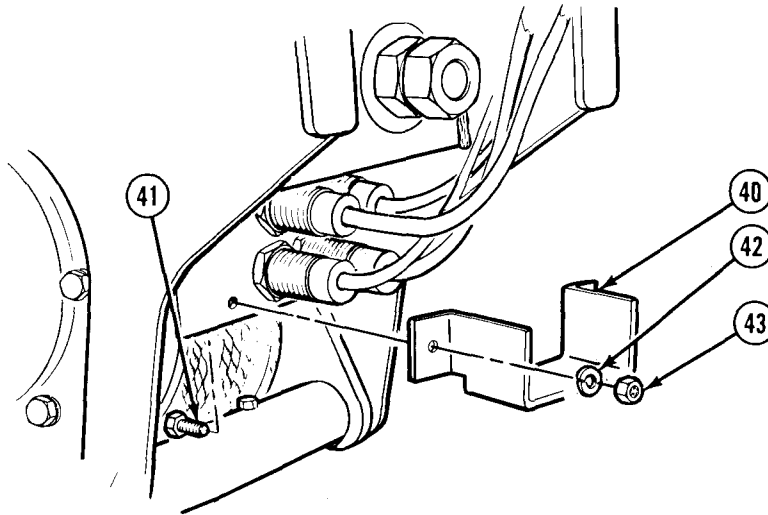

TA476405

(19) Install bracket (40) with two screws (41), lockwashers (42), and nuts (43).

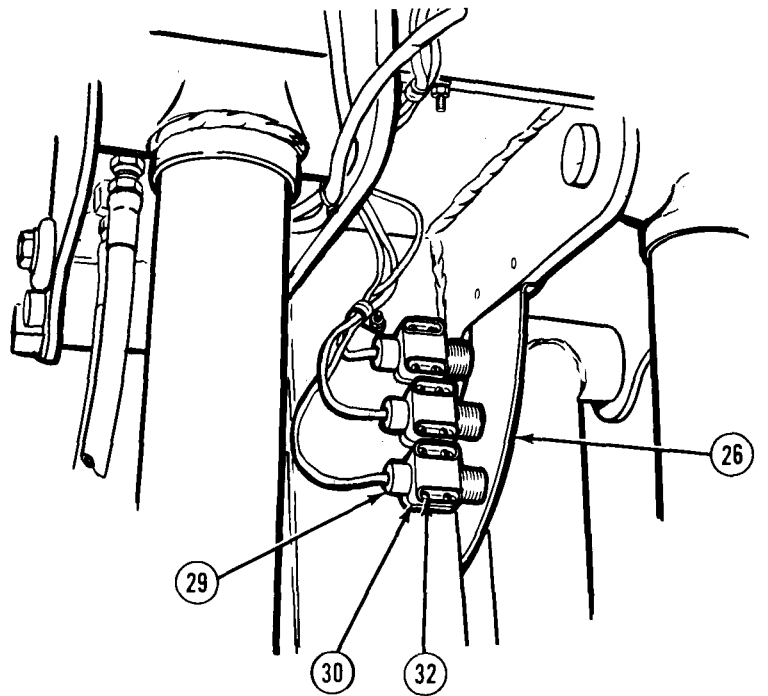

TA476406

N O T E

Settings are made the same way for all three overload switches.

(20) Loosen four screws (32) and adjust mounting flange (30) so overload switch (29) is 3/16 in. (4.76 mm) from sensor plate (26). Tighten screws (32).

Electrical System Maintenance Instructions (Cont)

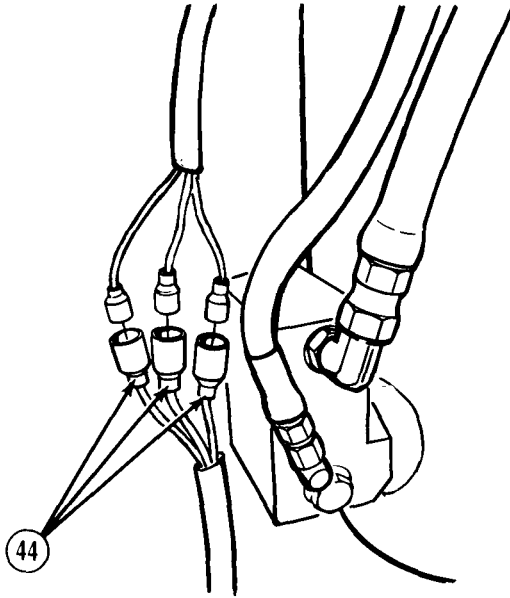

TA476407

(21) Connect three connectors (44).

c. **Follow-on Maintenance.** Adjust hoist overload protection switches (para 17-25.1).

END OF TASK

Electrical System Maintenance Instructions (Cont)

Section IV. WIRING HARNESSSES

6-13. CAB WIRING HARNESS REMOVAL/INSTALLATION.

This task covers:

- a. Removal
- b. Installation
- c. Follow-on Maintenance

INITIAL SETUP

Models

All

Test Equipment

None

Special Tools

Insert removal tool 114010

Supplies

- Connector, electrical, butt, Item 31, Appendix C
- Tags, identification, Item 60, Appendix C
- Tape, insulation, electrical, Item 62, Appendix C
- Ties, cable, plastic, Item 65, Appendix C

Personnel Required

MOS 63W, Wheel vehicle repairer

References

None

Equipment Condition

TM or Para

Condition Description

- TM 9-2320-279-20 Batteries disconnected.
- TM 9-2320-279-20 Instrument panel removed.
- TM 9-2320-279-20 TRACTION CONTROL switch removed.
- TM 9-2320-279-20 Starter switch removed.
- TM 9-2320-279-20 TRACTION CONTROL indicator light removed.
- TM 9-2320-279-20 ENGINE STOP switch removed.
- TM 9-2320-279-20 ETHER START switch removed.

Special Environmental Conditions

None

General Safety Instructions

Wheels chocked.

Level of Maintenance

Direct Support

a. Removal.

NOTE

- Tag and mark all wires.
 - Remove all clamps and plastic cable ties as necessary.
- (1) Disconnect connector (1) from flasher relay (2). Remove wire (3) from connector (1).
 - (2) Disconnect six wires (4) from turn signal connectors (5).

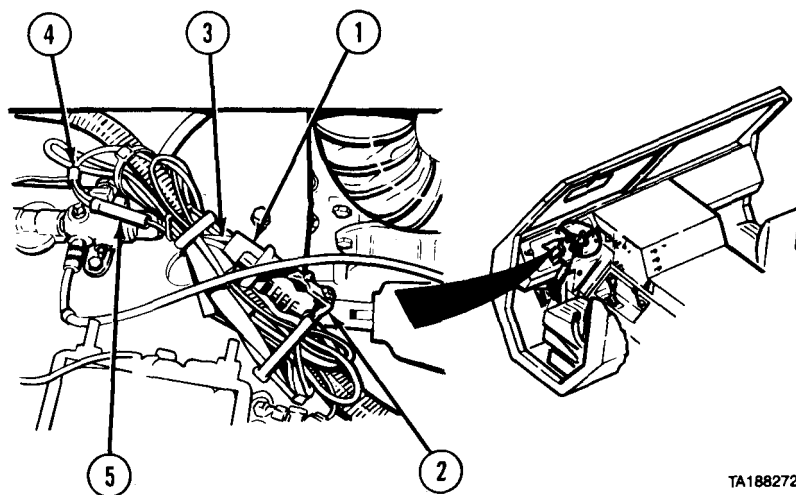

TA188272

Electrical System Maintenance Instructions (Cont)

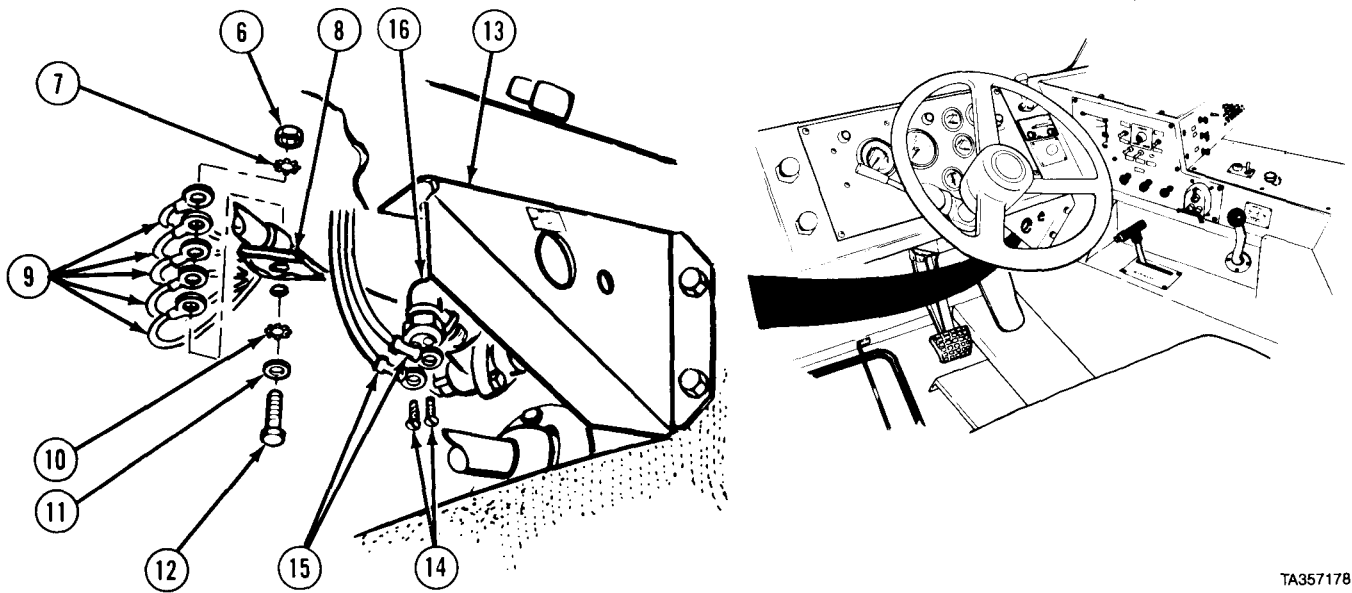

- (3) Remove nut (6), lockwasher (7), clip (8), five ground wires (9), lockwasher (10), washer (11), and screw (12) from panel (13).
- (4) Remove two screws (14) and wires (15) from switch (16).

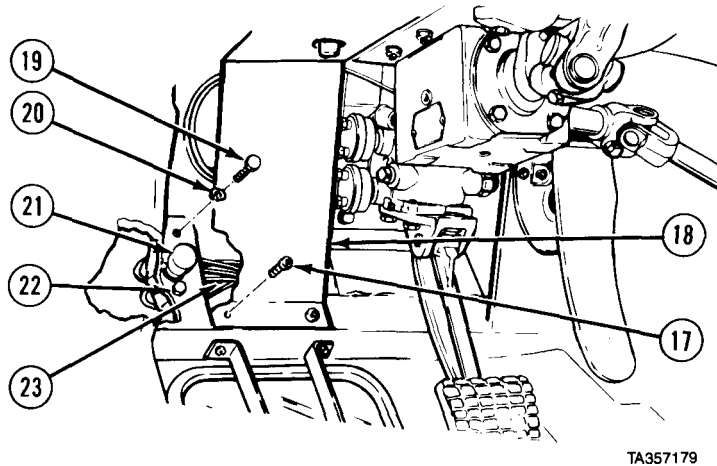

- (5) Remove four screws (17) and headlight guard (18).
- (6) Remove two screws (19) and lockwashers (20). Remove dimmer switch (21) from bracket (22).
- (7) Remove six wires (23) from dimmer switch (21).

Electrical System Maintenance Instructions (Cont)

6-13. CAB WIRING HARNESS REMOVAL/INSTALLATION (CONT).

- (8) Disconnect two turn signal light connectors (24 and 25).
- (9) Disconnect three plugs (26) from left headlight (27).
- (10) Remove four nuts (28), washers (29), and 10 wires (30) from each of two brake stoplight switches (31).

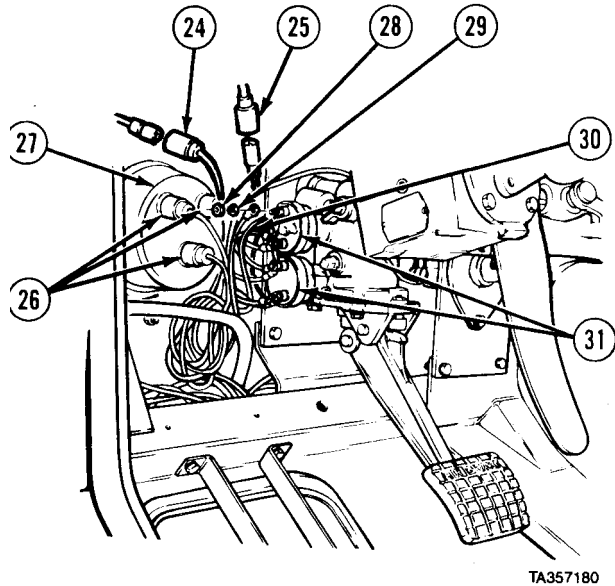

TA357180

- (11) Disconnect two wires (32) from brake low air switches (33) at right of brake treadle valve (34).

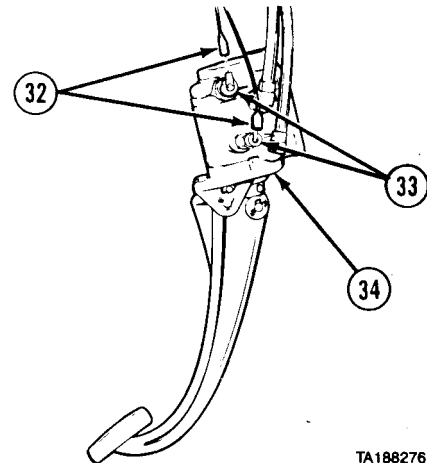

TA188276

- (12) Disconnect three wires (35) from left composite light connectors (36).

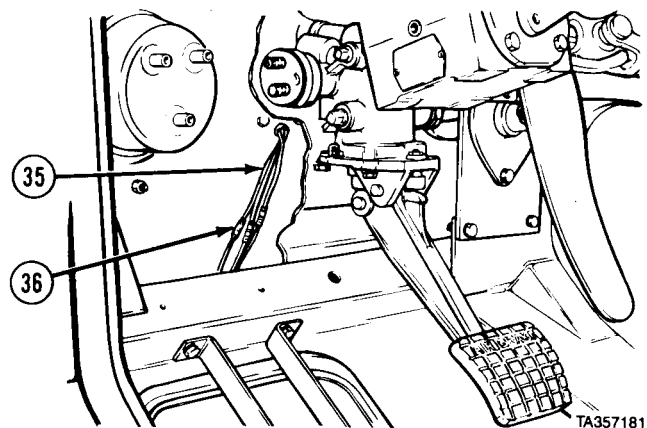

TA357181

Electrical System Maintenance Instructions (Cont)

(13) Using insert removal tool, disconnect left step clearance light wire (37) from plug (38).

(13.1) Remove two screws (38.1) and left step clearance light housing (38.2).

(13.2) Remove mounting screw (38.3), left step clearance light-to-cab ground wire (38.4), and pigtail ground wire (38.5) from left step clearance light base (38.6).

(14) Using insert removal tool, disconnect right step clearance light wire (39) from plug (40).

(14.1) Remove two screws (40.1) and right step clearance light housing (40.2).

(14.2) Remove mounting screw (40.3), right step clearance light-to-cab ground wire (40.4), and pigtail ground wire (40.5) from right step clearance light base (40.6).

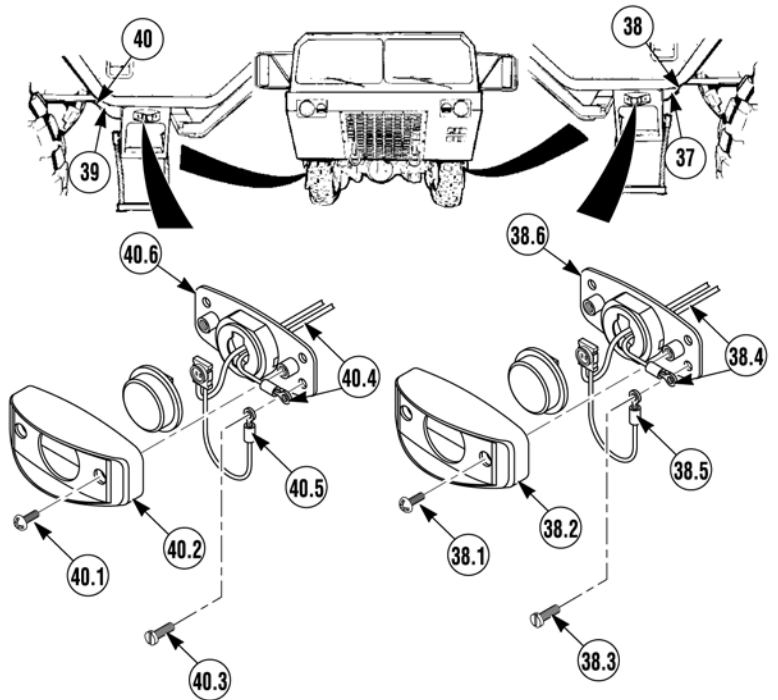

(15) Disconnect connector (41) from left and right front marker lights (42).

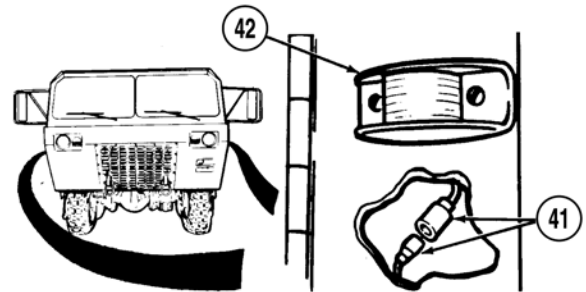

(16) Disconnect two wires (43) from connectors (44) at electric horns (45).

(17) Disconnect plug (46) from blackout light (47).

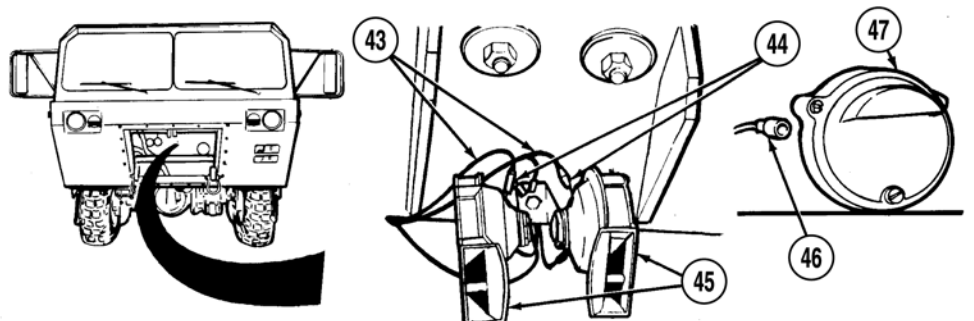

Electrical System Maintenance Instructions (Cont)

6-13. CAB WIRING HARNESS REMOVAL/INSTALLATION (CONT).

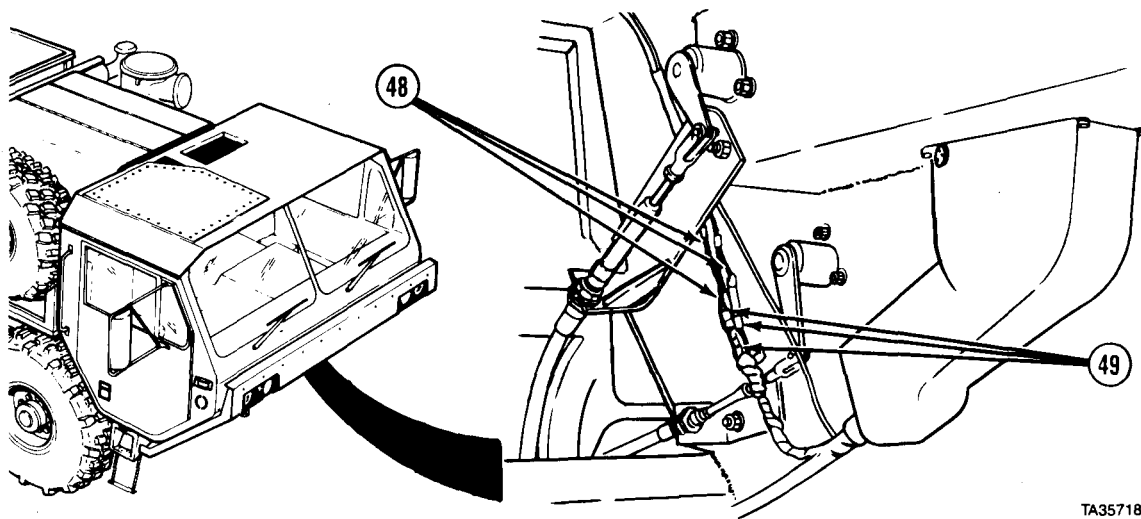

TA357184

(18) Remove electrical tape from three neutral start switch wires (48) and disconnect wires at connectors (49).

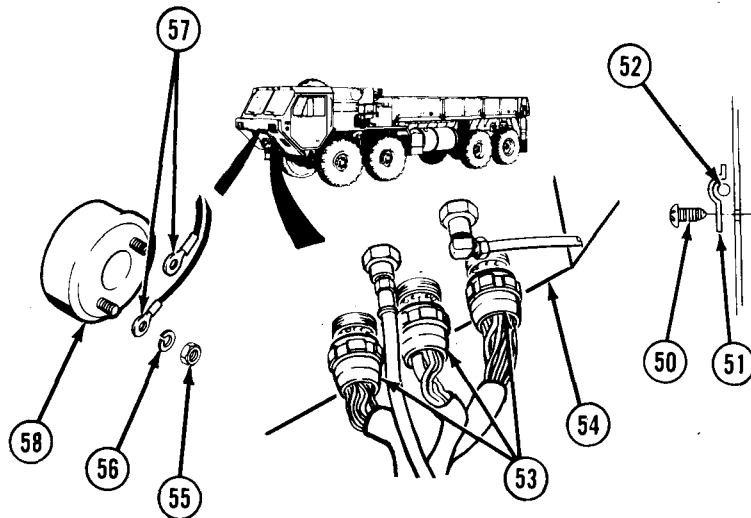

- (19) Remove screw (50), clamp (51), and heater control cable (52).
- (20) Disconnect three chassis wiring harness plugs (53) from under console (54).
- (21) Remove two nuts (55), lockwashers (56), and two wires (57) from stoplight switch (58).

Electrical System Maintenance Instructions (Cont)

- (22) Remove 11 screws (59) and two heater compartment covers (60).
- (23) Remove eight screws (61) and heater compartment cover (62).

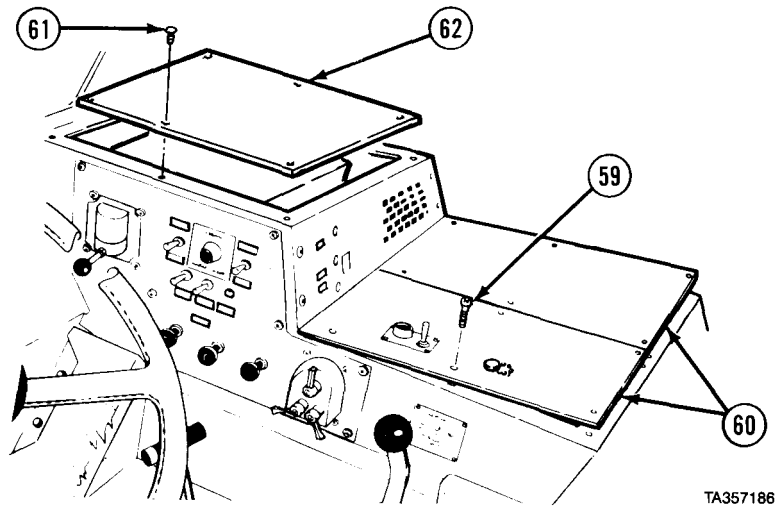

- (24) Disconnect plug (63) from power takeoff (PTO) harness (64).
- (25) Disconnect connector (65).
- (26) Disconnect connector (66).

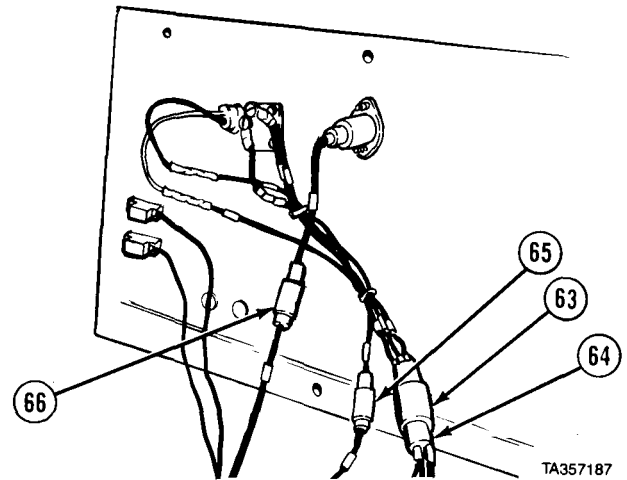

- (27) Disconnect plug (67) from main light switch (68).

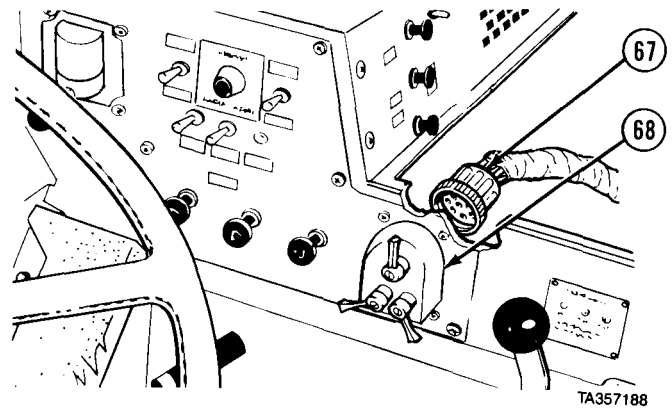

Electrical System Maintenance Instructions (Cont)

6-13. CAB WIRING HARNESS REMOVAL/INSTALLATION (CONT).

- (28) Remove eight screws (69) and console side panel (70).
- (29) Disconnect three wires (71) from ON/OFF switch (72) and HIGH/LOW switch (73).

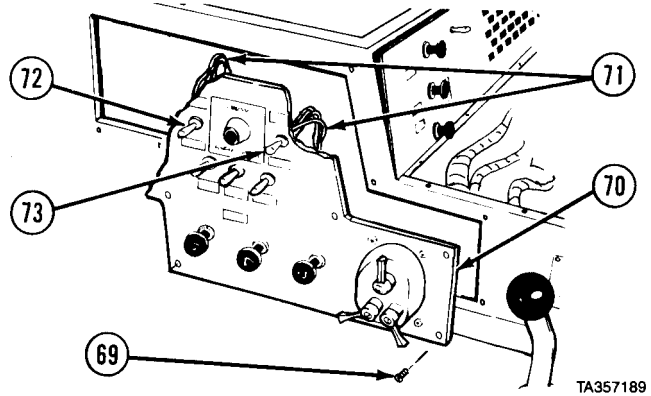

NOTE

WORK LIGHT switch is on M983, M984, and M984E1 only.

- (30) Disconnect two wires (74 and 75) from domelight switch (76) and WORK LIGHT switch (77). Disconnect three wires (78) from CLLPS switch (79).

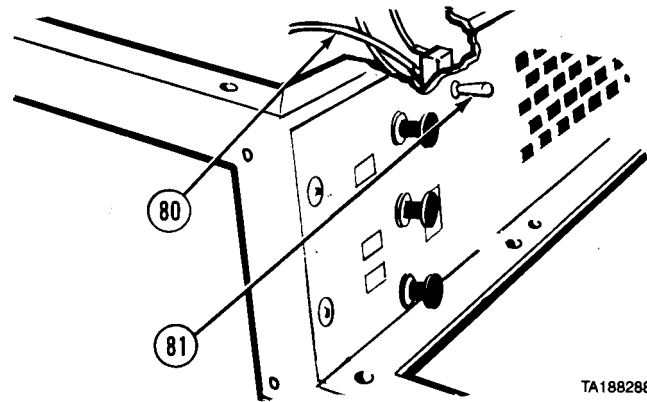
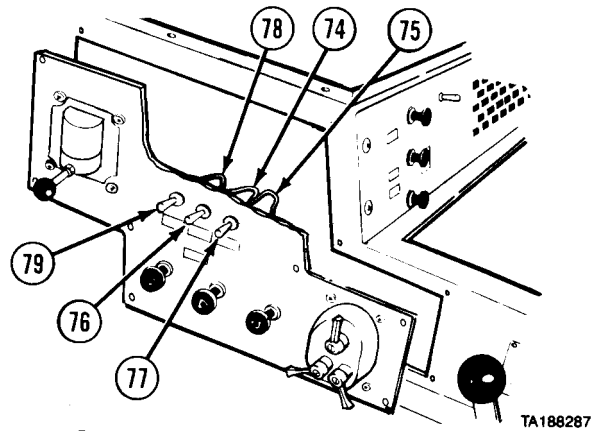

- (31) Disconnect wire (80) from center terminal of heater fan switch (81).

Electrical System Maintenance Instructions (Cont)

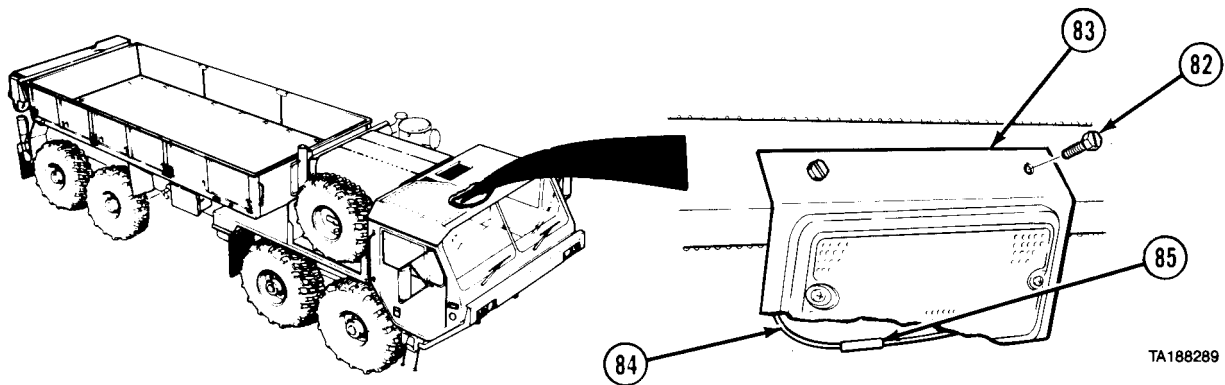

(32) Remove two screws (82) and domelight (83).

NOTE

Domelight wire will have to be pulled up through console.

(33) Disconnect domelight wire (84) at connector (85).

(34) Remove four screws (86) and headlight guard (87).

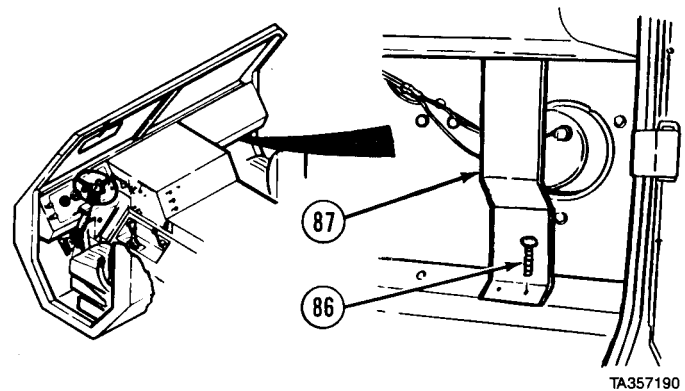

(35) Disconnect three plugs (88) from right headlight (89).

(36) Remove screw (90), washer (91), lockwasher (92), nut (93), and clip (94) holding cab wiring harness (95).

(37) Disconnect three wire connectors (96) from right composite light wires (97).

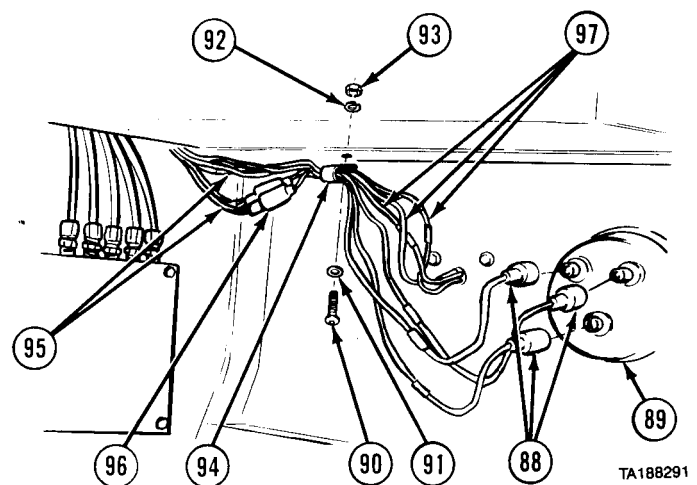

Electrical System Maintenance Instructions (Cont)

6-13. CAB WIRING HARNESS REMOVAL/INSTALLATION (CONT).

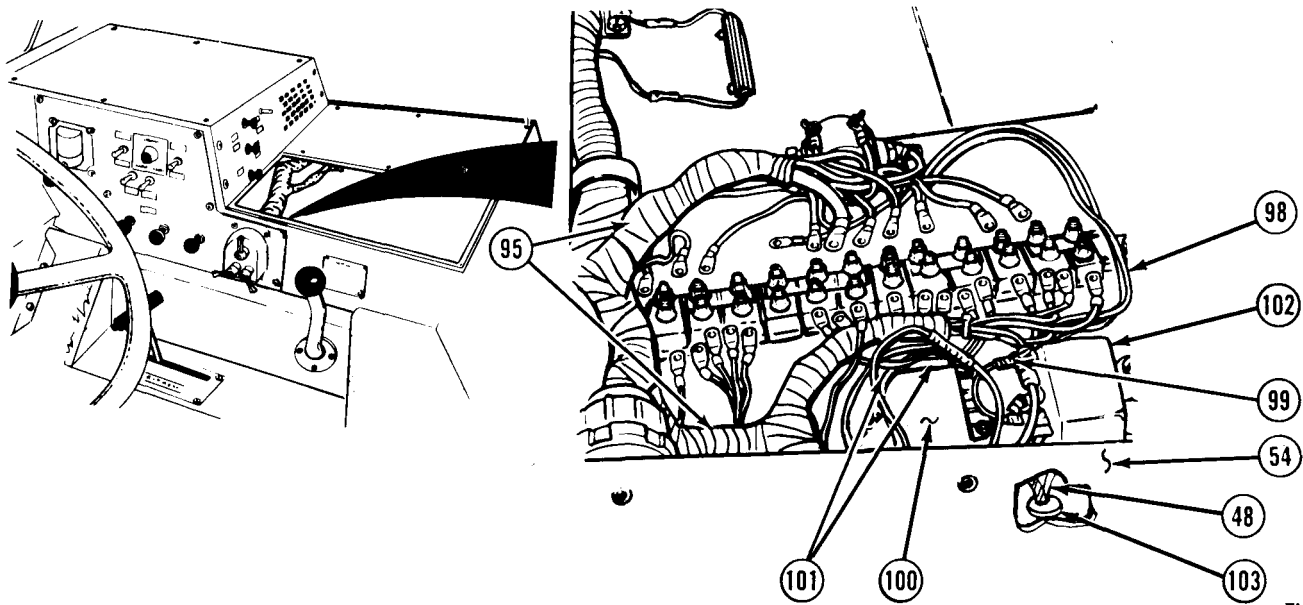

TA357221

- (38) Disconnect cab wiring harness (95) from circuit breaker rack (98) inside console (54).
- (39) Disconnect one harness wire (99) from starter relay (100) and two harness wires (101) from horn relay (102).
- (40) Pull neutral start switch wires (48) out through grommet (103).
- (41) Remove grommet (103) from console (54).

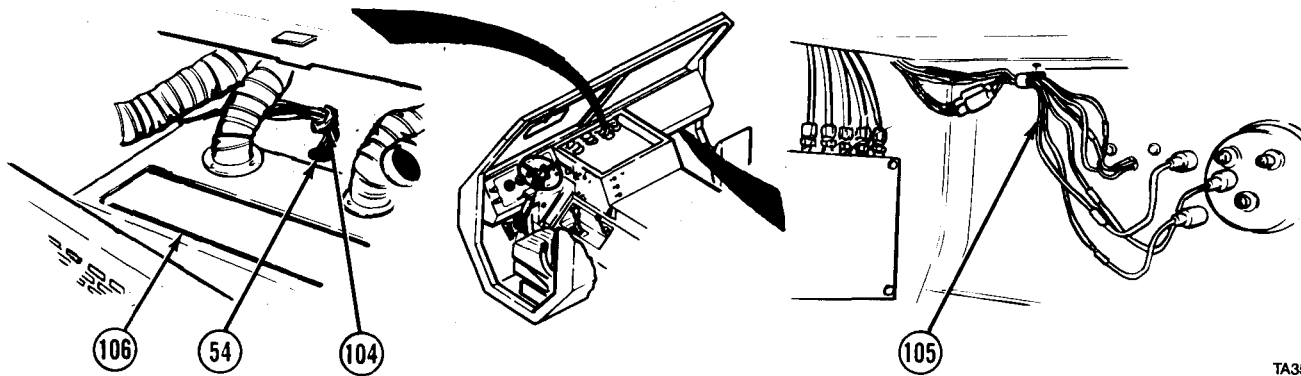

TA357191

- (42) Remove grommet (104) from console (54).
- (43) Remove right composite light wires (105) from heater compartment (106).

Electrical System Maintenance Instructions (Cont)

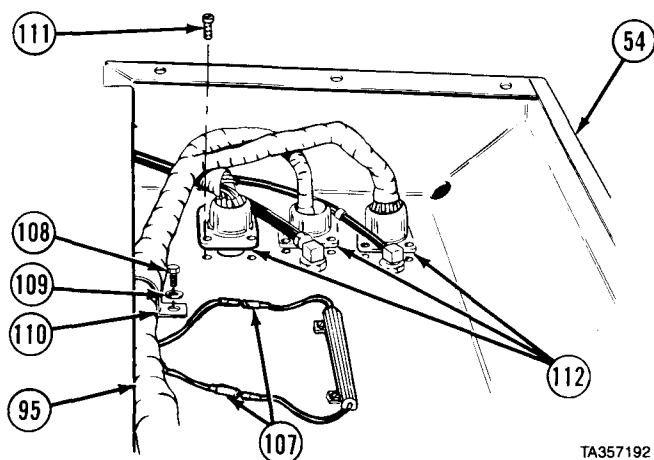

- (44) Disconnect two connectors (107).
- (45) Remove three screws (108), washers (109), and clamps (110) holding cab wiring harness (95).
- (46) Remove 12 screws (111) and three receptacles (112) from console (54).
- (47) Remove cab wiring harness (95).

b. Installation.

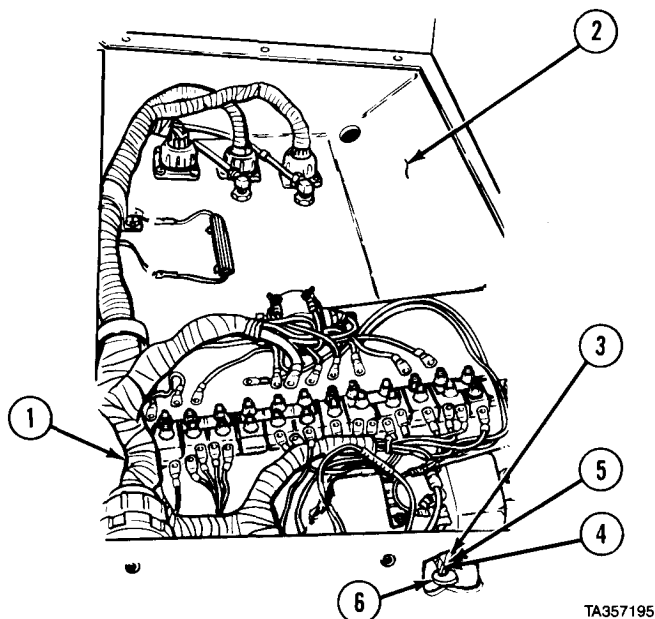

NOTE

All cab wiring harness connections need to be secure. Tie all excess wiring together with plastic cable ties.

- (1) Install cab wiring harness (1) in console (2).
- (2) Push domelight wire (3), three neutral start switch wires (4), and left step clearance light wire (5) through grommet (6).
- (3) Install grommet (6) in console (2).

Electrical System Maintenance Instructions (Cont)

6-13. CAB WIRING HARNESS REMOVAL/INSTALLATION (CONT.)

- (4) Install three receptacles (7) with 12 screws (8).
- (5) Install three clamps (9) with screws (10) and washers (11).
- (6) Connect two connectors (12).
- (7) Connect two harness wires (13) to starter relay (14).
- (8) Connect one harness wire (15) to horn relay (16).
- (9) Connect cab wiring harness (1) to circuit breaker rack (17).

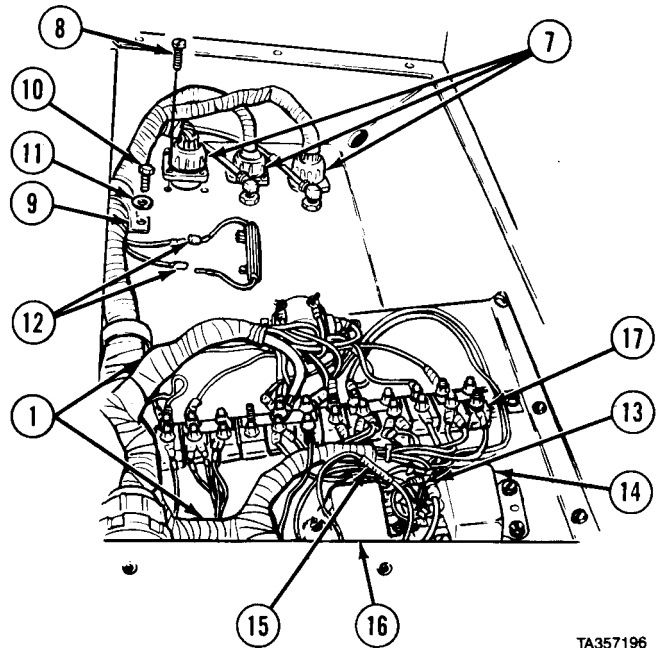

TA357196

- (10) Pull right composite light wires (18) through hole in heater compartment (19).

NOTE

Tie right composite light wires with plastic cable ties.

- (11) Route right composite light wires (18) through clip (20) and install clip to glove box (21) with screw (22), washer (23), lockwasher (24), and nut (25).
- (12) Connect three right composite light wires (18) to wire connectors (26).
- (13) Connect three plugs (27) to right headlight (28).
- (14) Install headlight guard (29) with four screws (30).

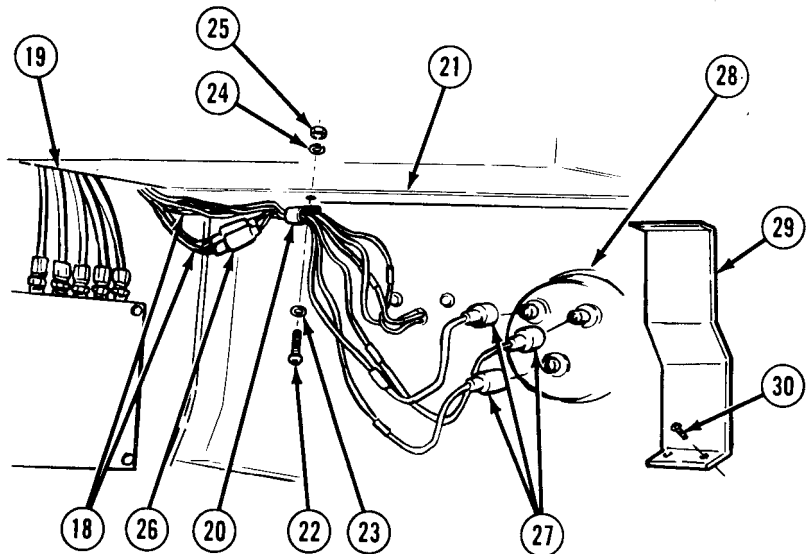

TA357197

Electrical System Maintenance Instructions (Cont)

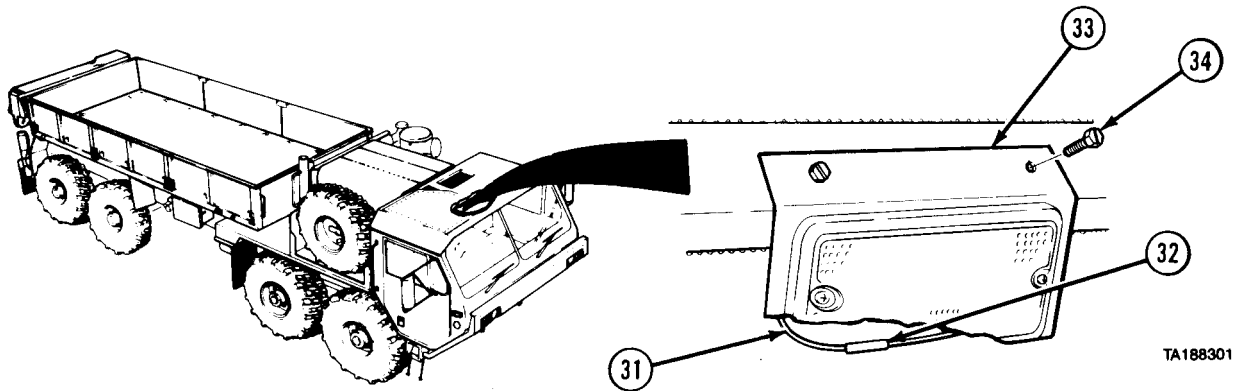

TA188301

(15) Connect domelight wire (31) to connector (32).

(16) Install domelight (33) with two screws (34).

(17) Connect wire (35) to center terminal on heater fan switch (36).

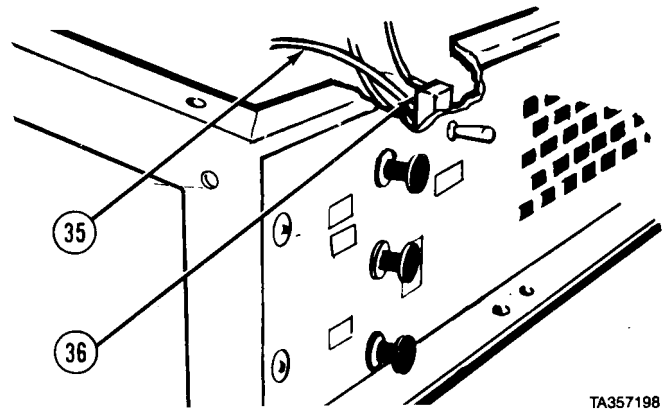

TA357198

NOTE

WORK LIGHT switch is on M983, M984, and M984E1 only.

(18) Connect two wires (37) to DOMELIGHT switch (38) and WORK LIGHT switch (39). Connect three wires (40) to CL LPS switch (41).

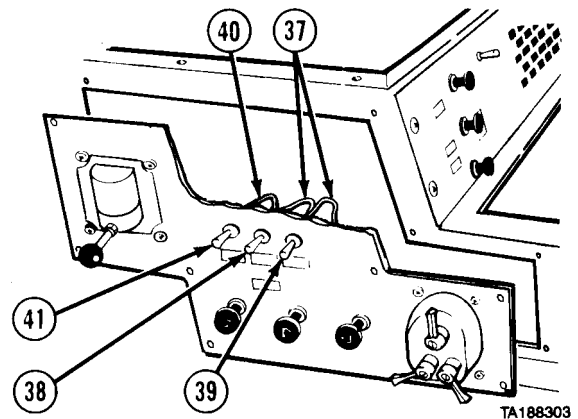

TA188303

Electrical System Maintenance Instructions (Cont)

6-13. CAB WIRING HARNESS REMOVAL/INSTALLATION (CONT).

NOTE

ENGINE BRAKE switches are identical. Install both switches so that up position is ON-HIGH and down position is OFF-LOW.

- (19) Connect three wires (42) to ON/OFF switch (43).
- (20) Connect three wires (44) to HIGH/LOW switch (45).
- (21) Install console side panel (46) with eight screws (47).

- (22) Connect plug (48) to main light switch (49) inside console side panel (46).

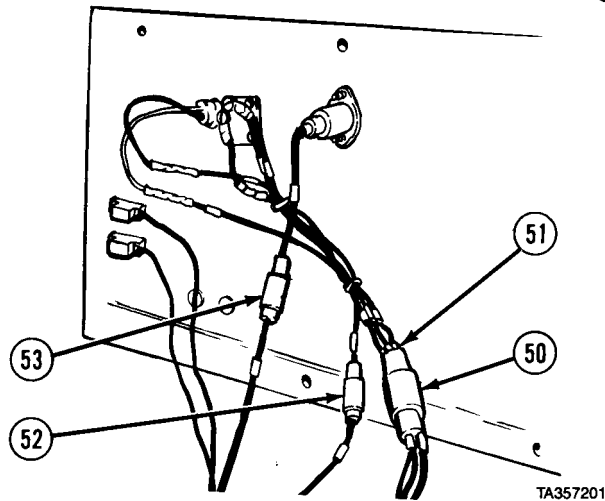
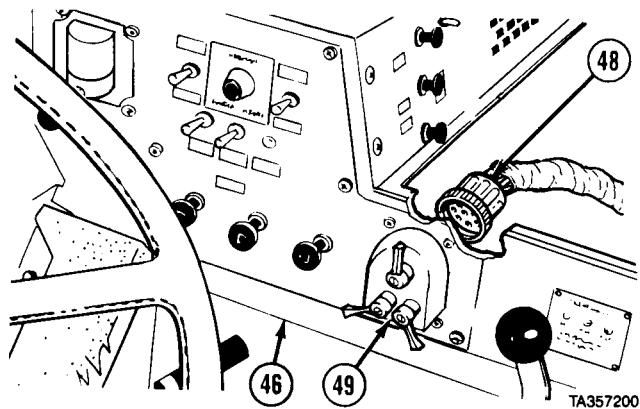
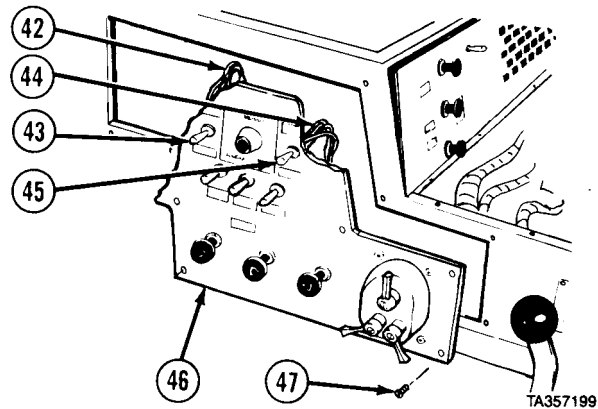

- (23) Connect plug (50) to power takeoff (PTO) harness (51).
- (24) Connect connector (52).
- (25) Connect connector (53).

Electrical System Maintenance Instructions (Cont)

- (26) Install grommet (54) in console (2).

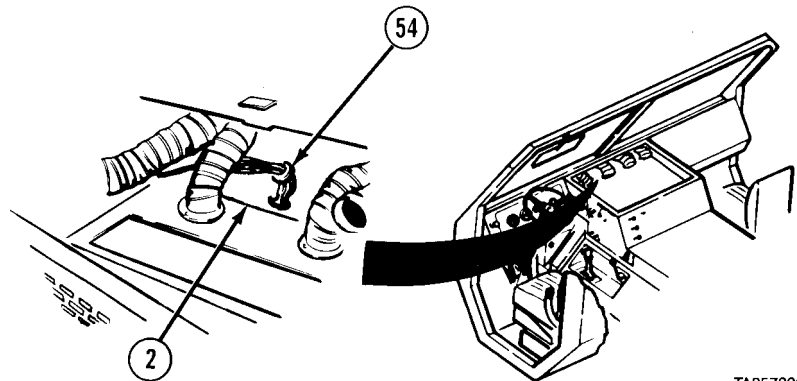

TA357202

- (27) Connect three chassis wiring harness plugs (55) to cab wiring harness connectors (56) under cab console floor (57).
 (28) Install heater control cable (58) with clamp (59) and screw (60).
 (29) Connect two wires (61) to stoplight switch (62) with two lockwashers (63) and nuts (64).

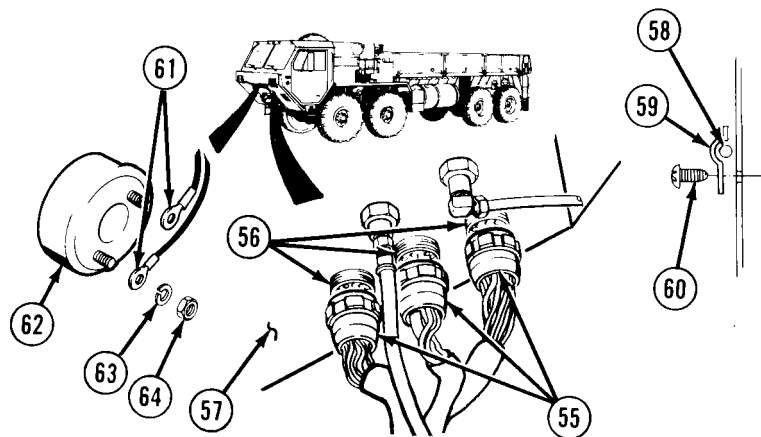

TA357203

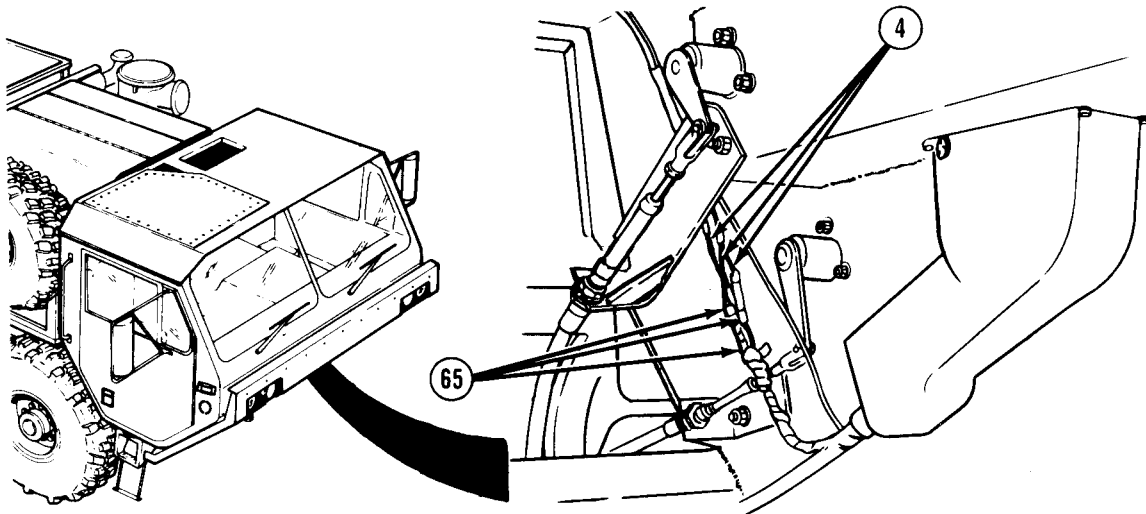

TA188310

- (30) Connect three neutral start switch wires (4) to connectors (65).
 (31) Wrap electrical tape over three neutral start switch wires (4) and connectors (65).

Electrical System Maintenance Instructions (Cont)

6-13. CAB WIRING HARNESS REMOVAL/INSTALLATION (CONT).

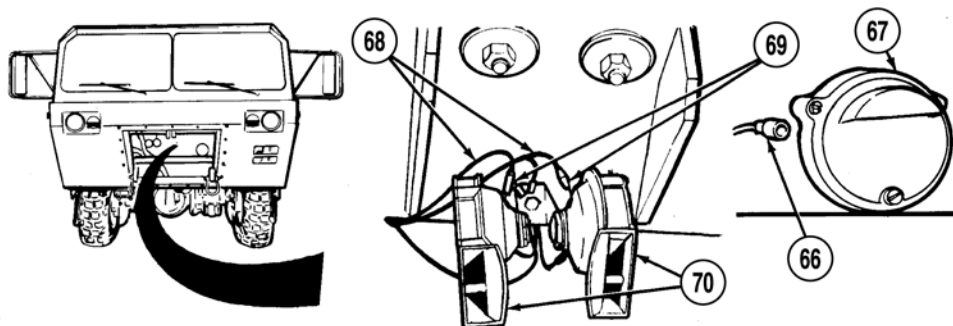

- (32) Connect plug (66) to blackout light (67).
- (33) Connect two wires (68) to connectors (69) at electric horns (70).

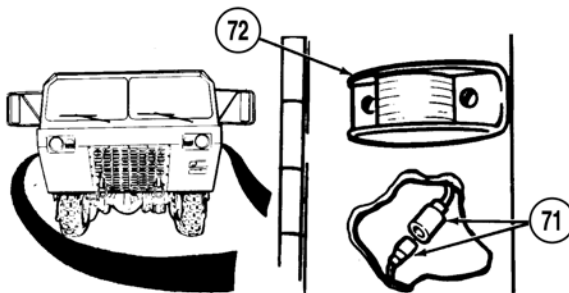

- (34) Connect connector (71) to right and left front marker lights (72).

Electrical System Maintenance Instructions (Cont)

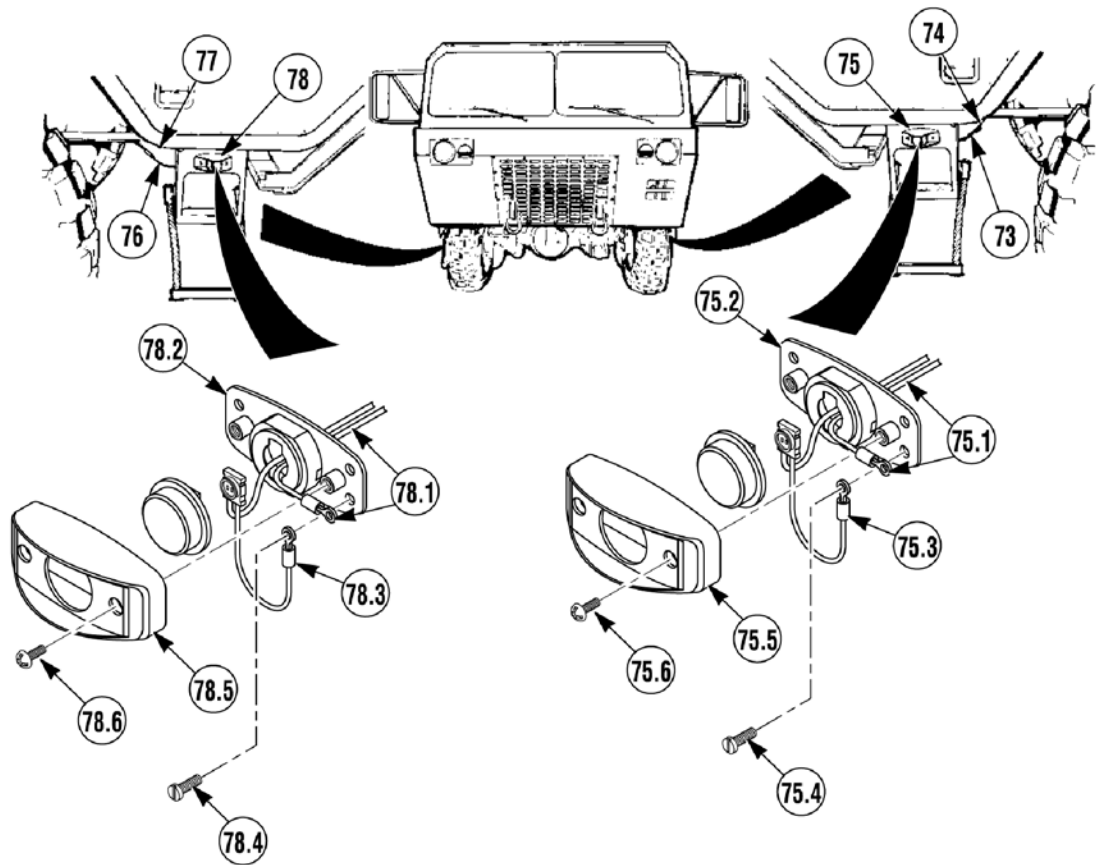

- (35) Using insert removal tool, connect wire (73) at plug (74) to left step clearance light (75).
- (35.1) Feed left step clearance light-to-cab ground wire (75.1) through left step clearance light base (75.2) from behind.
- (35.2) Attach left step clearance light-to-cab ground wire (75.1) and pigtail ground wire (75.3) to left step clearance light base (75.2) with mounting screw (75.4).
- (35.3) Install left step clearance light housing (75.5) on left step clearance light base (75.2) with two screws (75.6).
- (36) Using insert removal tool, connect wire (76) at plug (77) to right step clearance light (78).
- (36.1) Feed right step clearance light-to-cab ground wire (78.1) through right step clearance light base (78.2) from behind.
- (36.2) Attach right step clearance light-to-cab ground wire (78.1) and pigtail ground wire (78.3) to right step clearance light base (78.2) with mounting screw (78.4).
- (36.3) Install right step clearance light housing (78.5) on right step clearance light base (78.2) with two screws (78.6).

Electrical System Maintenance Instructions (Cont)

- (37) Connect three wires (79) to left composite light connectors (80).
- (38) Connect three plugs (81) to left headlight (82).
- (39) Connect two side turn signal wires (83) to connectors (84).

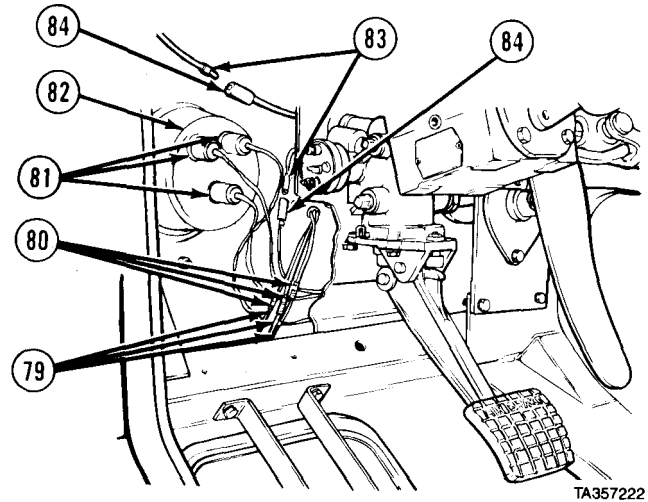

- (40) Install 10 wires (85) to each of two brake stoplight switches (86) with four nuts (87) and washers (88).

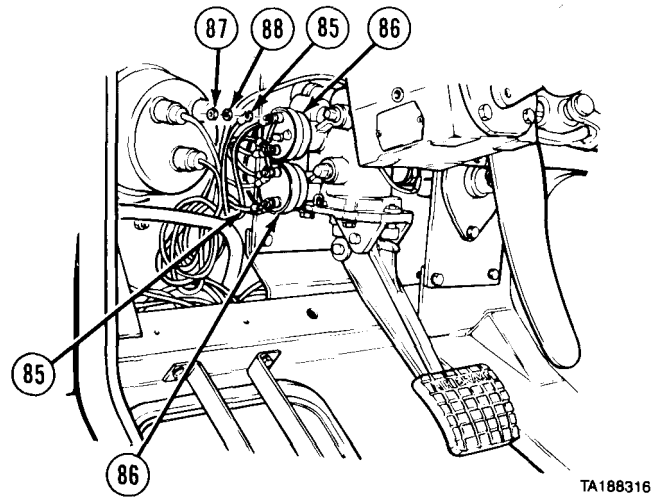

- (41) Connect two wires (89) to brake low air switches (90) at right of brake treadle valve (91).

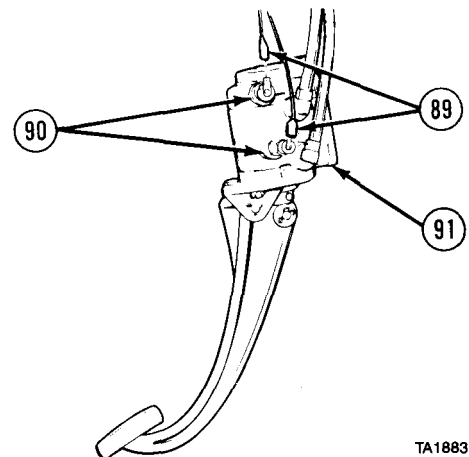

Electrical System Maintenance Instructions (Cont)

6-13. CAB WIRING HARNESS REMOVAL/INSTALLATION (CONT).

- (42) Connect six wires (92) to dimmer switch (93).
- (43) Install dimmer switch (93) on bracket (94) with two screws (95) and lockwashers (96).
- (44) Install headlight guard (97) with four screws (98).

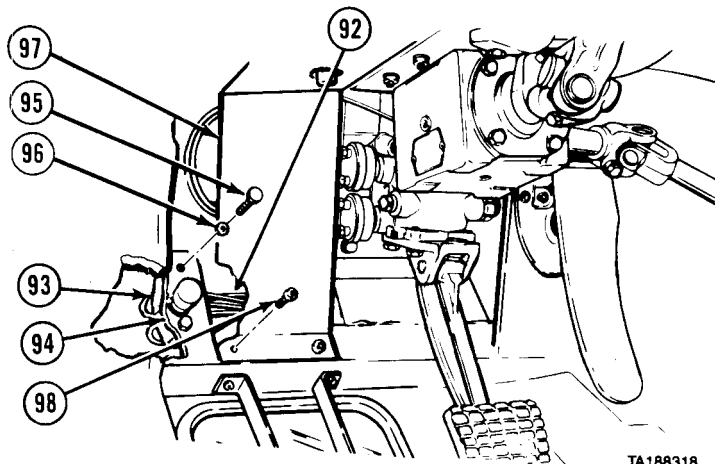

TA188318

- (45) Install clip (99) and five ground wires (100) behind panel (101) with screw (102), washer (103), lockwasher (104), lockwasher (105), and nut (106).
- (46) Install two wires (107) with screws (108) to switch (109).

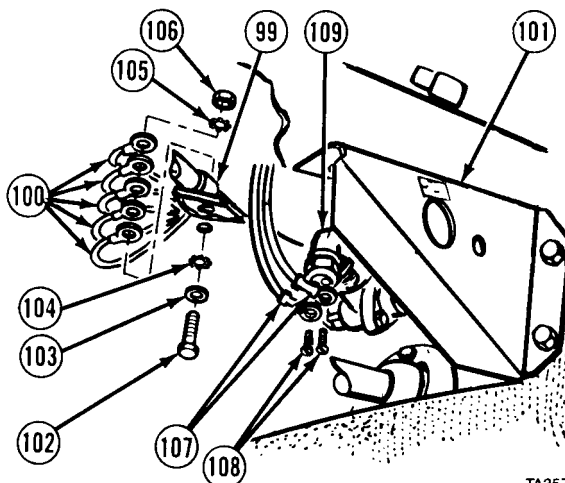

TA357206

- (47) Pull six wires (110) up into instrument compartment.
- (48) Connect six wires (110) to turn signal connectors (111).
- (49) Install wire (112) into connector (113). Install connector on flasher relay (114).

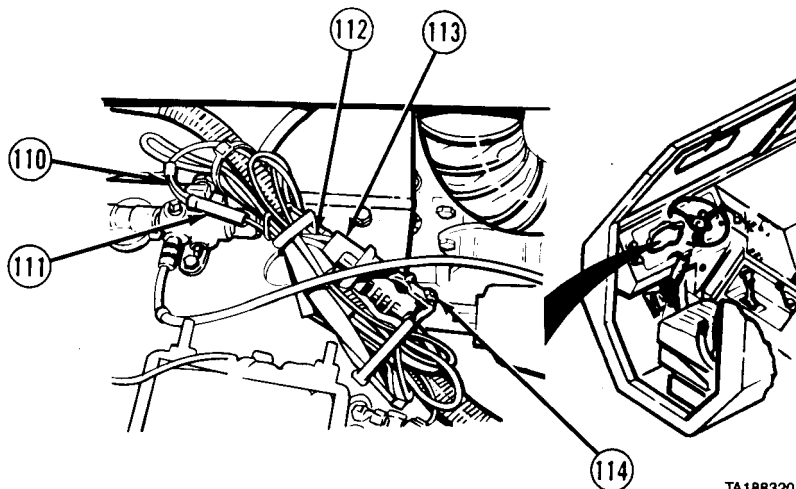

TA188320

Electrical System Maintenance Instructions (Cont)

- (50) Install two heater compartment covers (115) on console (2) with 11 screws (116).
- (51) Install heater compartment cover (117) with eight screws (118).

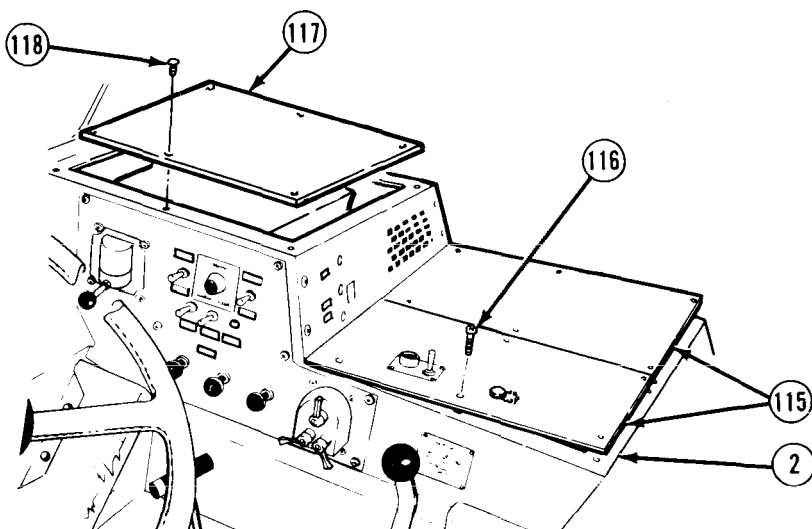

c. Follow-on Maintenance.

- (1) Install ETHER START switch (TM 9-2320-279-20).
- (2) Install starter switch (TM 9-2320-279-20).
- (3) Install TRACTION CONTROL switch (TM 9-2320-279-20).
- (4) Install ENGINE STOP switch (TM 9-2320-279-20).
- (5) Install TRACTION CONTROL indicator light (TM 9-2320-279-20).
- (6) Install instrument panel (TM 9-2320-279-20).
- (7) Connect batteries (TM 9-2320-279-20).

END OF TASK

6-14. ENGINE WIRING HARNESS REMOVAL/INSTALLATION.	
This task covers:	
a. Removal	c. Follow-on Maintenance
b. Installation	
INITIAL SETUP	
<i>Models</i> All	<i>Personnel Required</i> MOS 63W, Wheel vehicle repairer
<i>Test Equipment</i> None	<i>References</i> None
<i>Special Tools</i> None	<i>Equipment Condition</i> TM or Para Condition Description TM 9-2320-279-20 Batteries disconnected.
<i>Supplies</i> Connector, electrical butt, Item 31, Appendix C Sealant, RTV200 Electrical, Item 55.2, Appendix C Tags, identification, Item 60, Appendix C Tape, insulation, electrical, Item 62, Appendix C Ties, cable, plastic, Item 65, Appendix C	<i>Special Environmental Conditions</i> None <i>General Safety Instructions</i> None <i>Level of Maintenance</i> Direct Support

Electrical System Maintenance Instructions (Cont)

6-14. ENGINE WIRING HARNESS REMOVAL/INSTALLATION (CONT).

a. Removal.

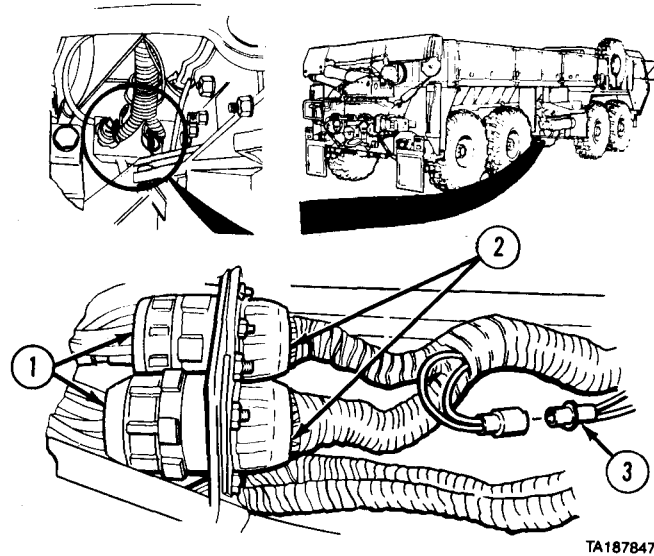

NOTE

- Tag and mark all connections and wires before disconnecting.
- Cut plastic cable ties as necessary.

- (1) Disconnect two connectors (1) from two receptacles (2).
- (2) Disconnect two-pin connector (3).

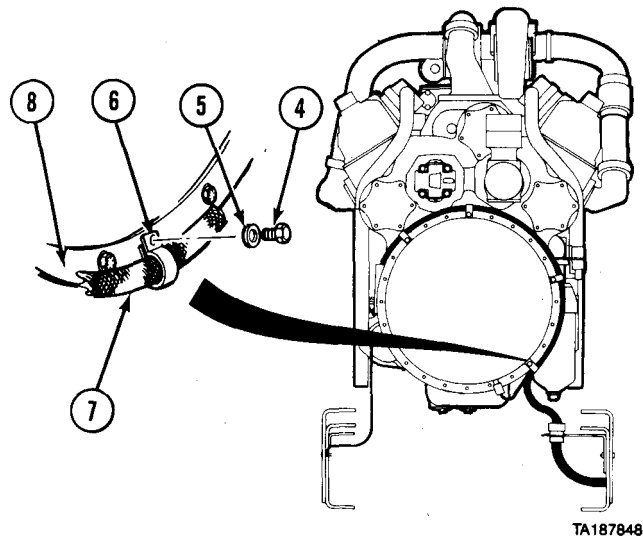

NOTE

M984E1 has only two cushion clips.

- (3) Remove screw (4), washer (5), and cushion clip (6) to free engine harness (7) from lower right flange of transmission (8).

Electrical System Maintenance Instructions (Cont)

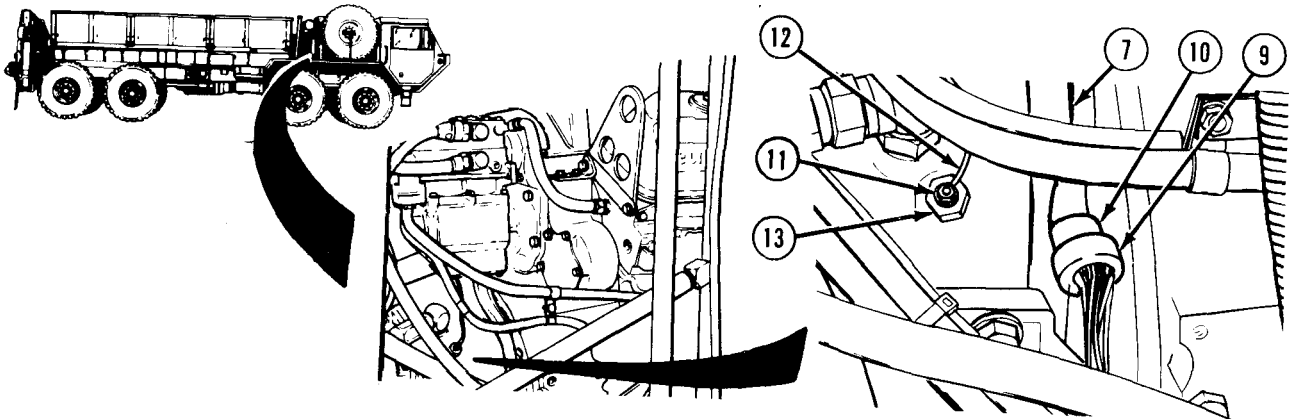

TA187849

- (4) Disconnect STE/ICE harness (9) from engine harness (7) at connector (10).
- (5) Remove nut (11) and disconnect wire (12) from transmission temperature sending unit (13).

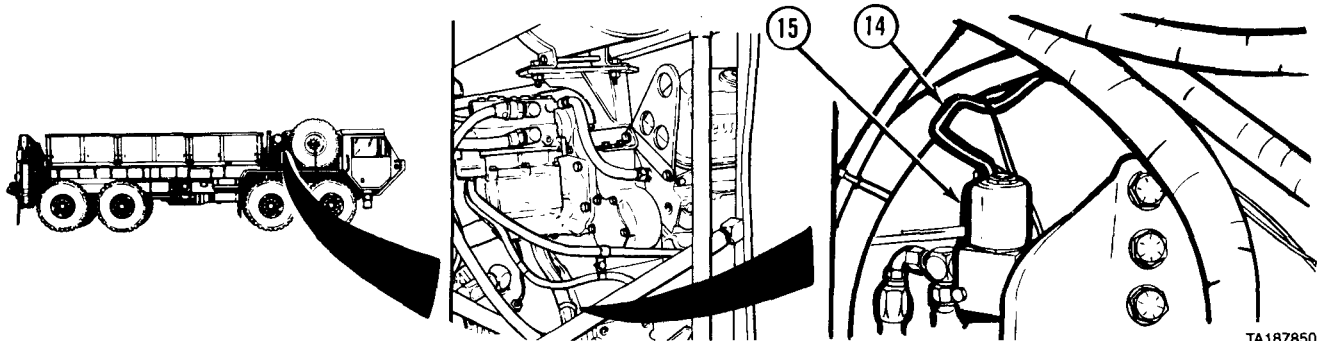

TA187850

- (6) Cut wire (14) to transmission lockup solenoid (15).

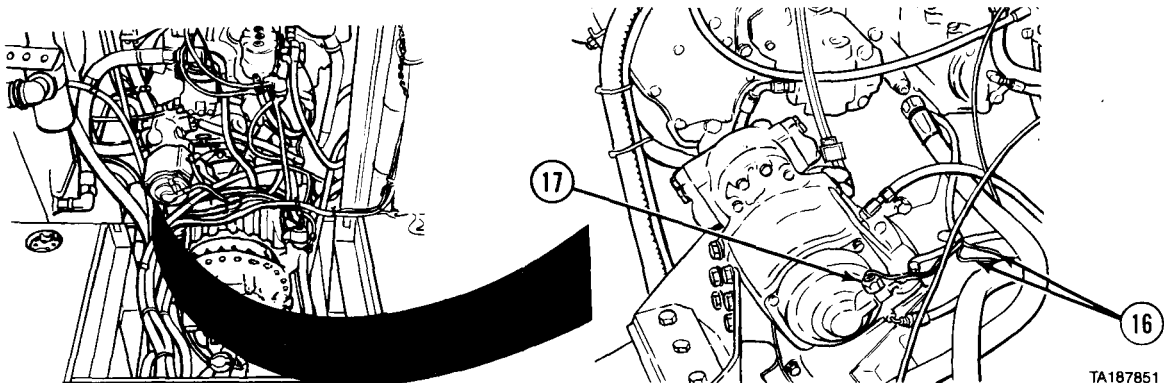

TA187851

NOTE

On M984E1, power takeoff is turned around.

- (7) Disconnect connector (16) from power takeoff solenoid (17).

Electrical System Maintenance Instructions (Cont)

16-14. ENGINE WIRING HARNESS REMOVAL/INSTALLATION (CONT).

NOTE

Ž All cushion clips are removed the same way.

- M984E1 does not have cushion clip.

(8) Remove screw (18), washer (19), and cushion clip (20) to free engine harness (7) from upper flange of transmission (8).

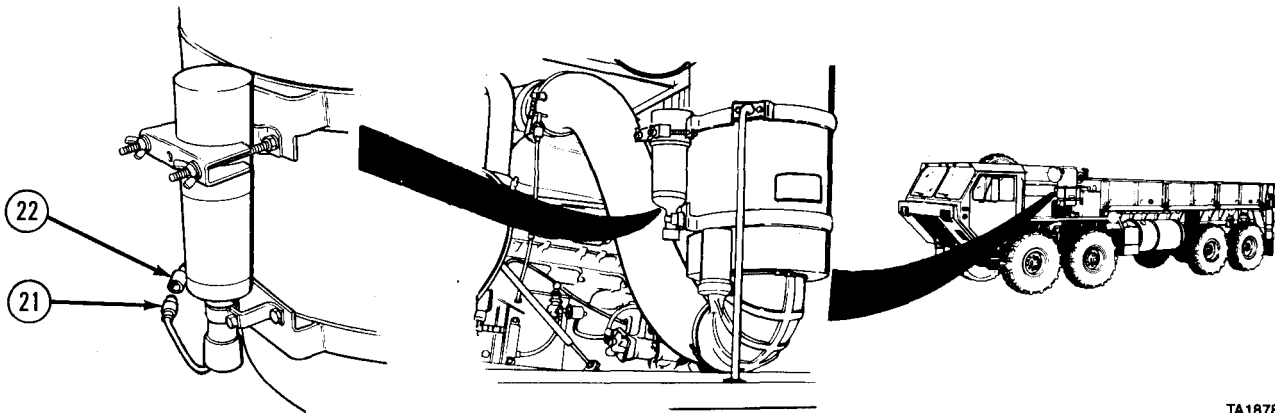
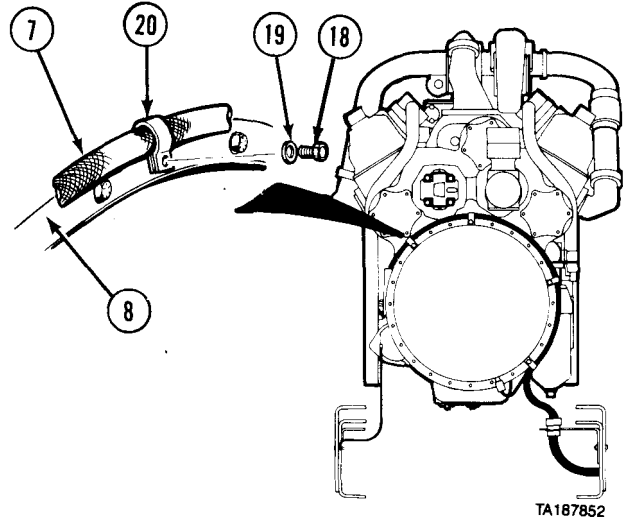

(9) Disconnect ether start plug (21) at harness socket (22).

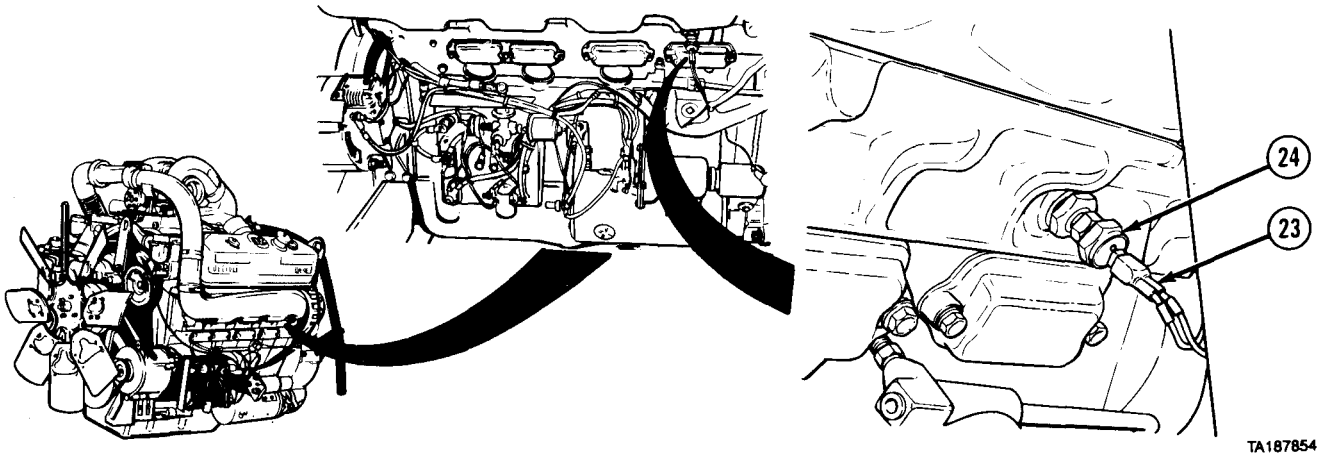

(10) Disconnect two wires (23) from water temperature thermostat (24).

Electrical System Maintenance Instructions (Cont)

- (11) Disconnect wire from tachometer sending unit (25) at harness connector (26).
- (12) Cut wire to disconnect high idle solenoid wire at connector (27).

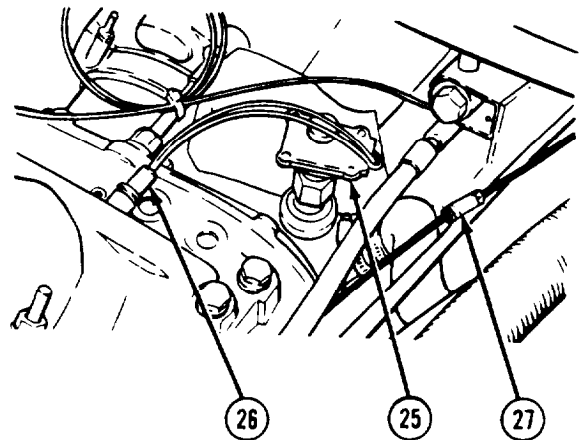

TA187855

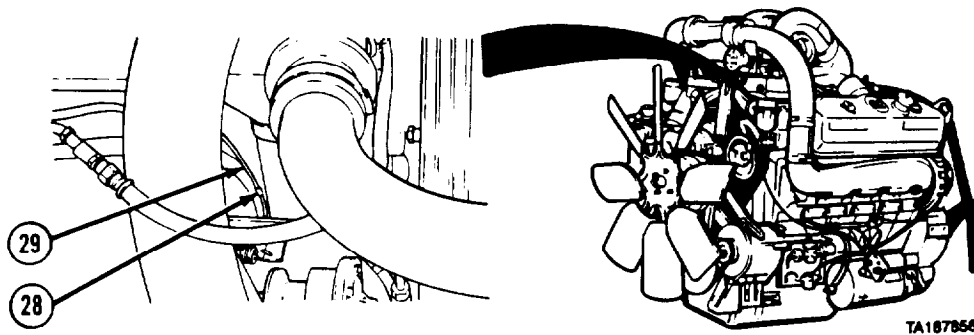

TA187856

- (13) Cut left engine brake wire (28) at electrical butt connector (29).

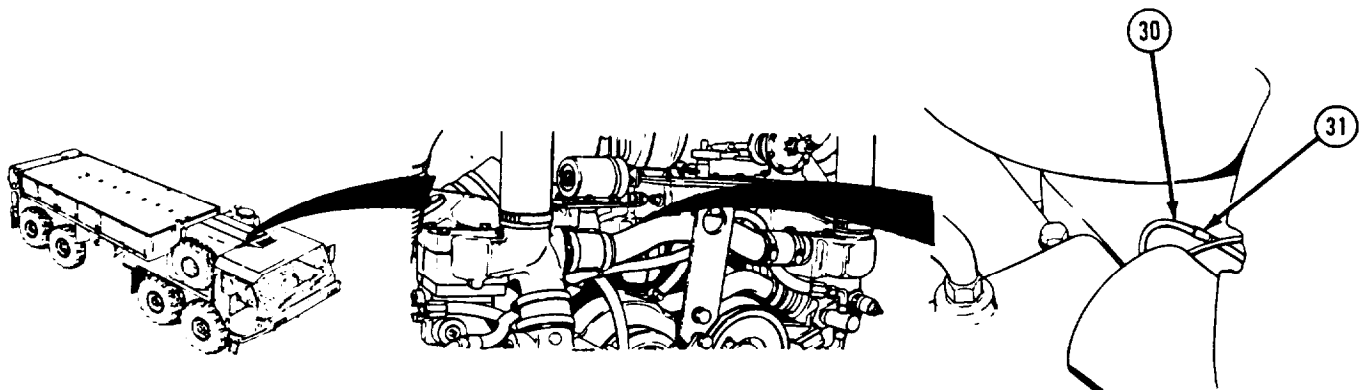

TA187857

- (14) Cut right engine brake wire (30) at electrical butt connector (31).

Electrical System Maintenance Instructions (Cont)

6-14. ENGINE WIRING HARNESS REMOVAL/INSTALLATION (CONT).

- (15) Disconnect two wires (32) from buffer switch (33) by pulling wires off switch terminals.
- (16) Remove two nuts (34) and disconnect two wires (35) from engine shutdown solenoid (36). Return nuts to shutdown solenoid terminals (37).

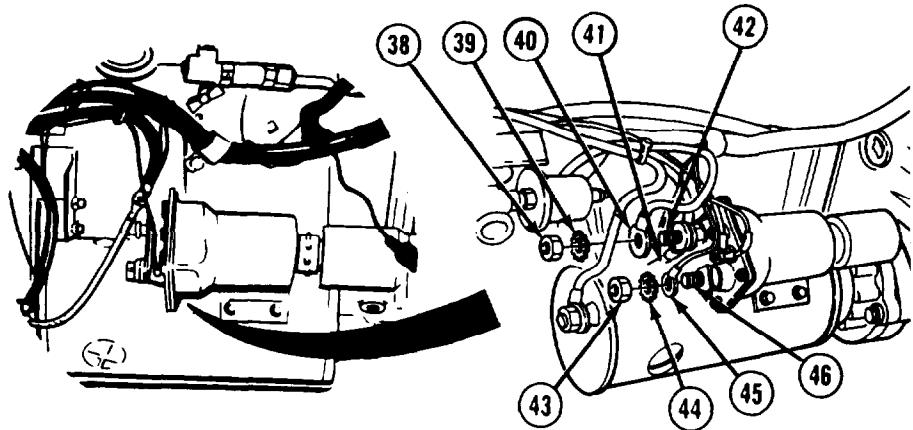
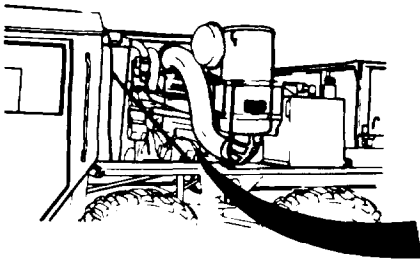
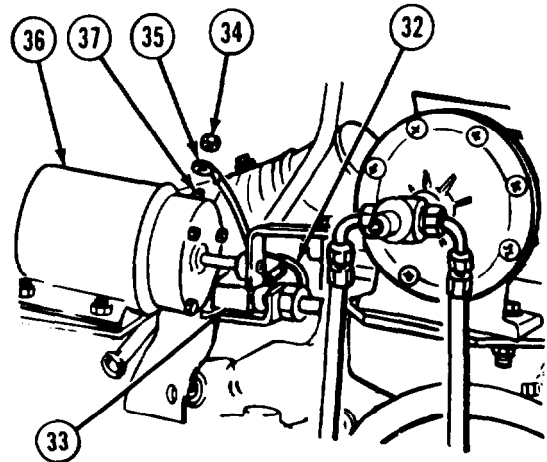

- (17) Remove nut (38) and washer (39). Disconnect wires (40 and 41) from starter solenoid terminal (42).
- (18) Remove nut (43), washer (44), and wire (45) from starter solenoid terminal (46).

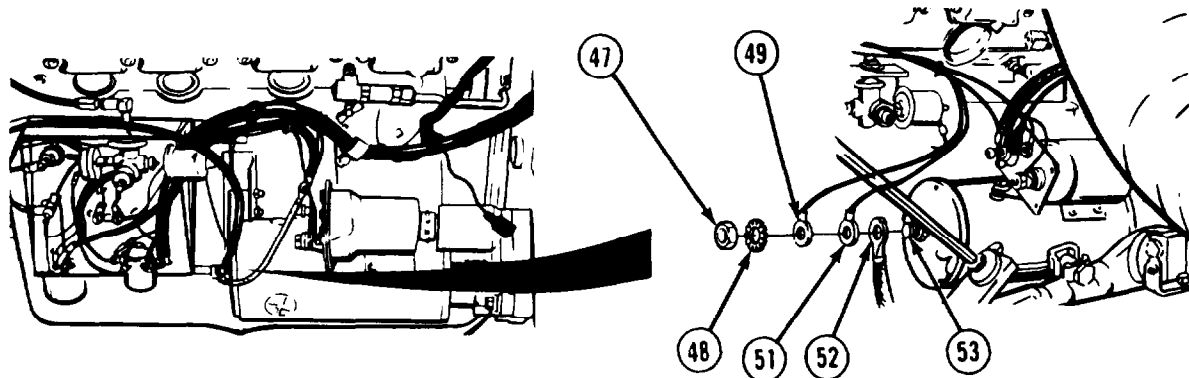

- (19) Remove nut (47) and lockwasher (48). Disconnect harness wires (49 and 51) and wire (52) from starter terminal (53).

Electrical System Maintenance Instructions (Cont)

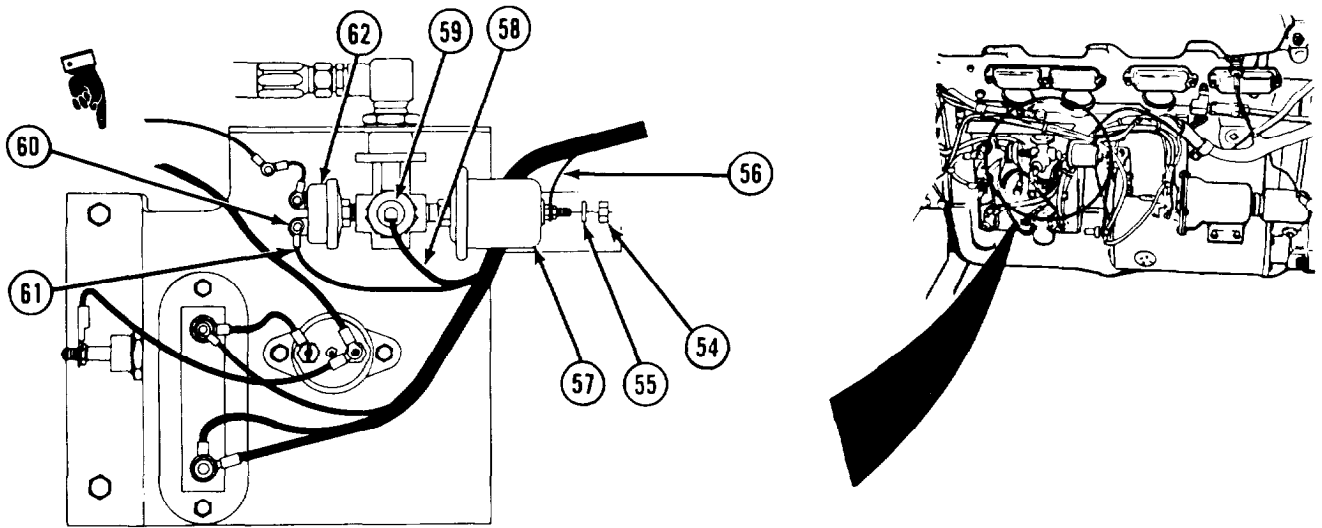

- (20) Remove nut (54) and lockwasher (55). Remove wire (56) from oil pressure sending unit (57).
- (21) Pull two wires (58) from low oil pressure switch (59).
- (22) Remove screw (60). Disconnect wire (61) from low engine oil switch (62).

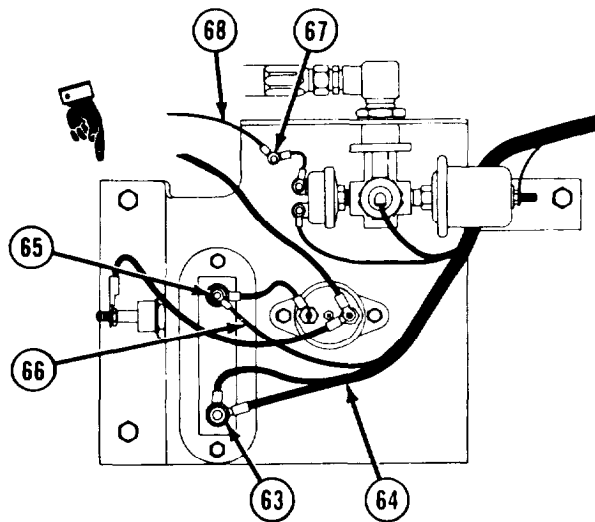

- (23) Remove screw (63) and disconnect wire (64).
- (24) Remove screw (65) and disconnect wire (66).
- (25) Remove screw (67) and disconnect ether start ground wire (68).

Electrical System Maintenance Instructions (Cont)

6-14. ENGINE WIRING HARNESS REMOVAL/INSTALLATION (CONT).

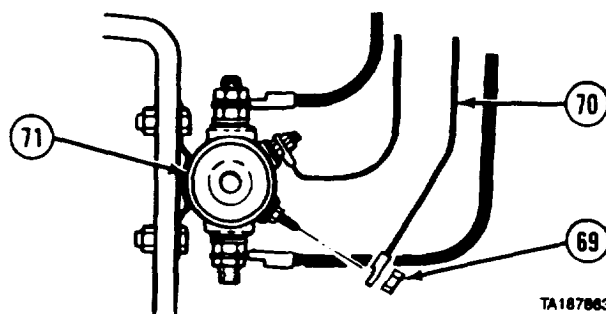
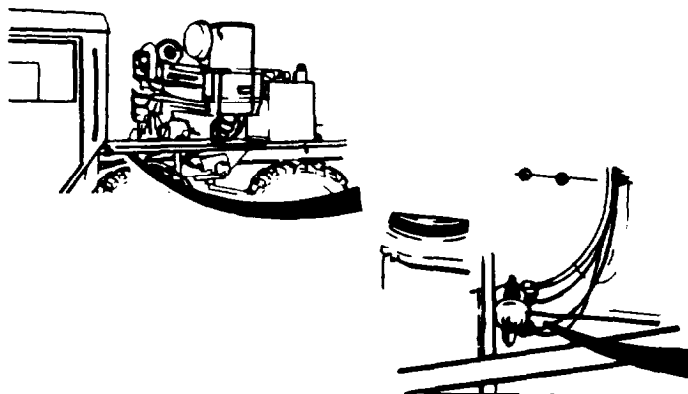

(26) Remove nut (69) and disconnect wire (70) from starter solenoid (71).

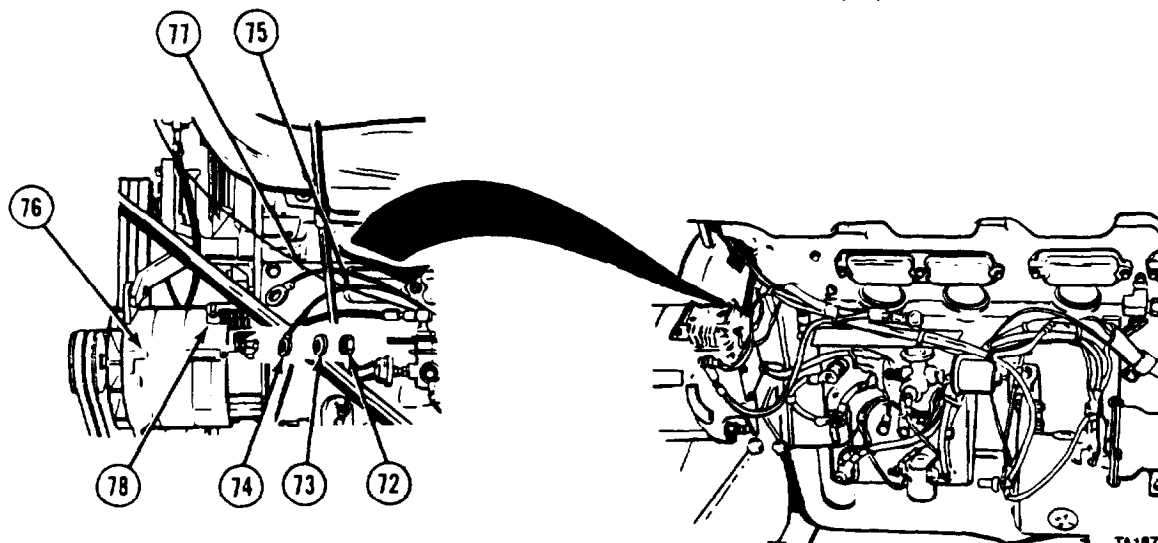

(27) Remove three nuts (72) and washers (73). Disconnect two wires (74 and 75) from terminals at alternator (76) and one wire (77) from alternator regulator (78).

Electrical System Maintenance Instructions (Cont)

- (28) Remove nut (79), lockwasher (80), and washer (81). Remove lead (82) from high water temperature switch (83).
- (29) Remove nut (84), lockwasher (85), and washer (86). Remove lead (87) from water temperature sending unit (88).

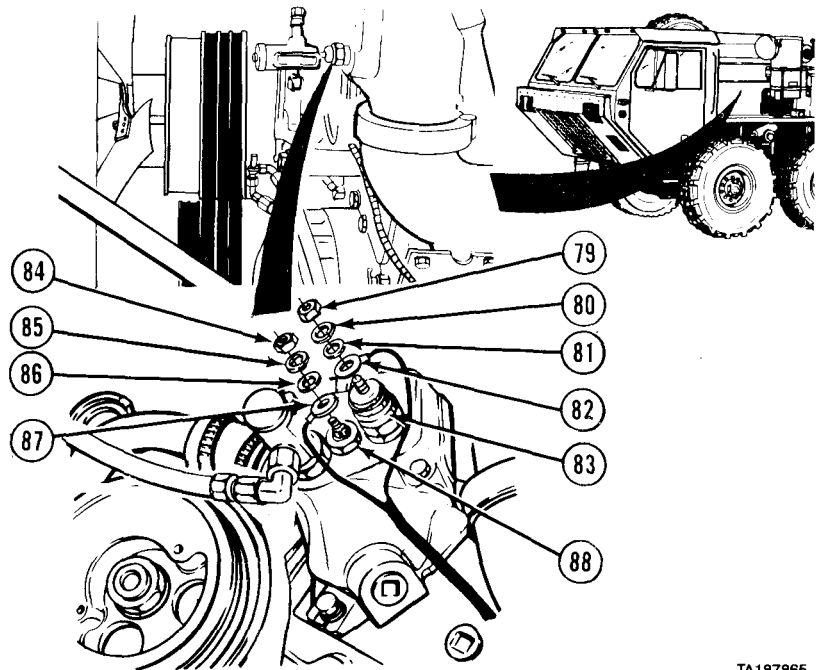

TA187865

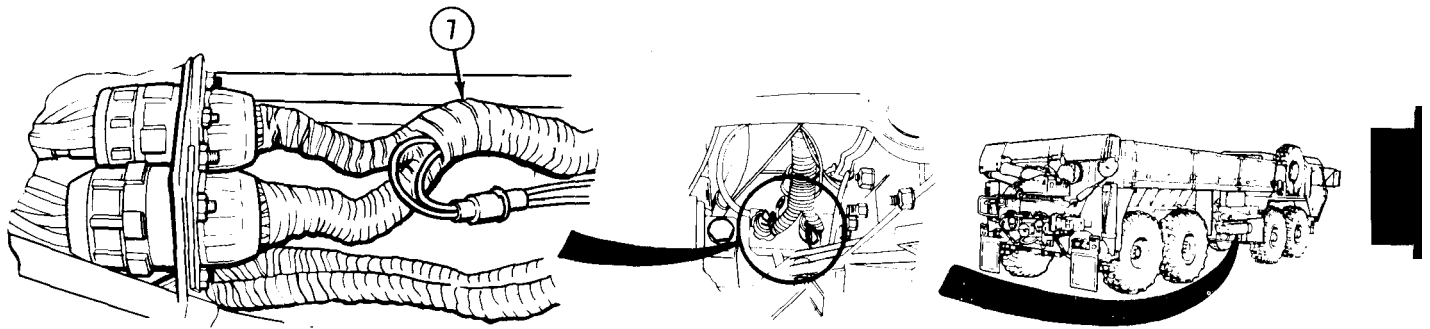

TA187866

NOTE

Check that all harness wires are disconnected.

- (30) Pull harness (7) from engine, down under vehicle, and remove harness.

Electrical System Maintenance Instructions (Cont)

6-14. ENGINE WIRING HARNESS REMOVAL/INSTALLATION (CONT).

b. Installation.

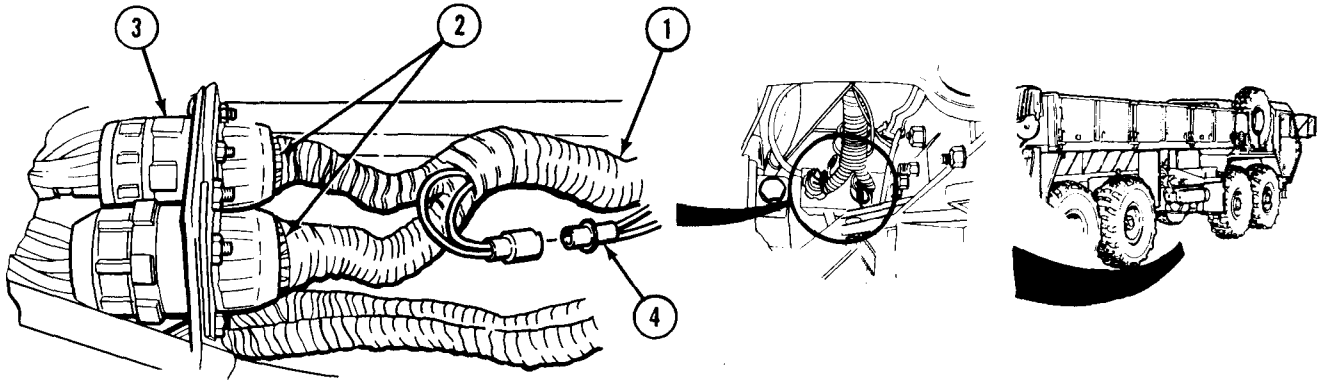

- (1) Wrap electrical tape around loose wires of harness (1) to make it easier to thread wires through engine.

WARNING

Adhesives, solvents, and sealing compounds can burn easily, can give off harmful vapors, and are harmful to skin and clothing. To avoid injury or death, keep away from open fire and use in well-ventilated area. If adhesive, solvent, or sealing compound gets on skin or clothing, wash immediately with soap and water.

NOTE

Apply electrical sealant to exposed wire connectors after installing connectors.

- (2) Install two connectors (2) to receptacles (3).
- (3) Connect two-pin connector (4).

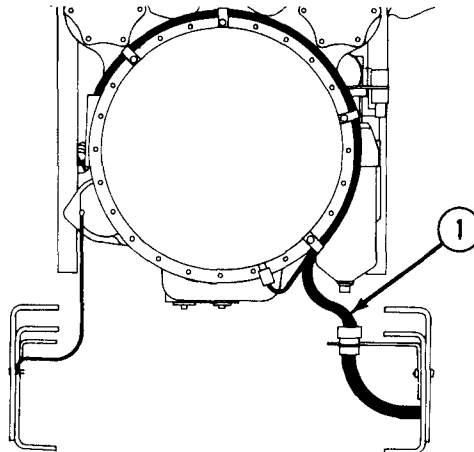

- (4) Begin threading taped ends of harness (1) through vehicle from beneath right rear corner of engine.

Electrical System Maintenance Instructions (Cont)

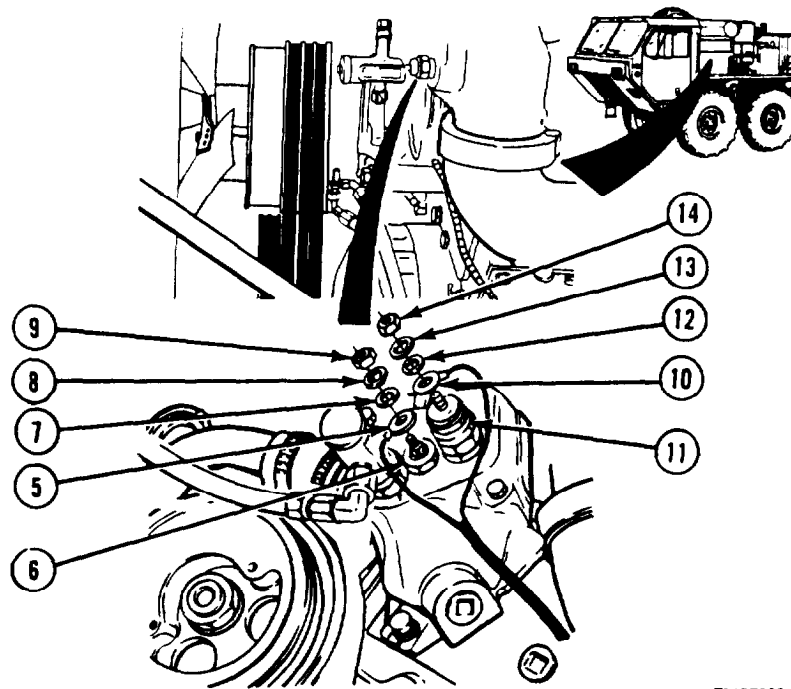

TA187869

NOTE

Remove tape, as necessary, to connect harness ends to component or connector.

- (5) Pull harness all the way to the left and connect lead (5) to water temperature sending unit (6) with washer (7) lockwasher (8) and nut (9).
- (6) Connect lead (10) to high water temperature switch (11) with washer (12), lockwasher (13), and nut (14).

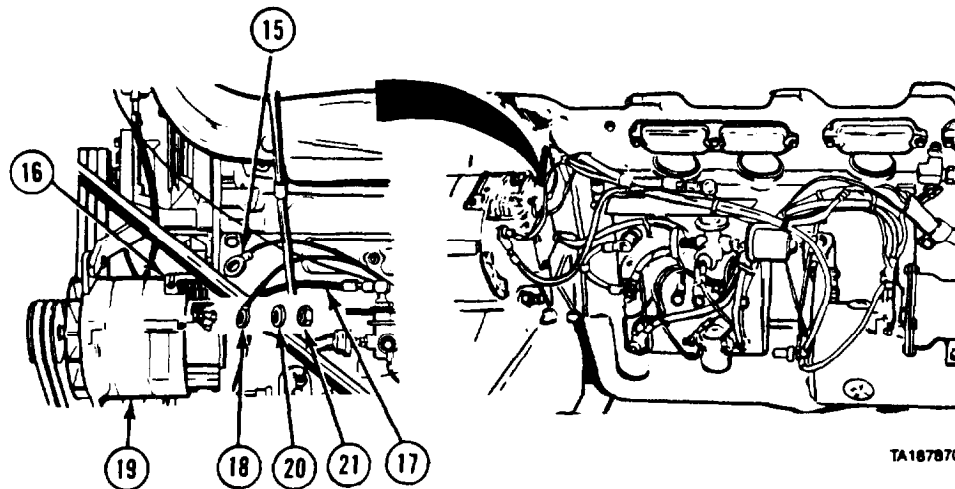

TA187870

- (7) Connect wire (15) to alternator regulator (16) and wires (17 and 18) to terminals of alternator (19). Secure each wire with washer (20) and nut (21).

Electrical System Maintenance Instructions (Cont)

6-14. ENGINE WIRING HARNESS REMOVAL/INSTALLATION (CONT).

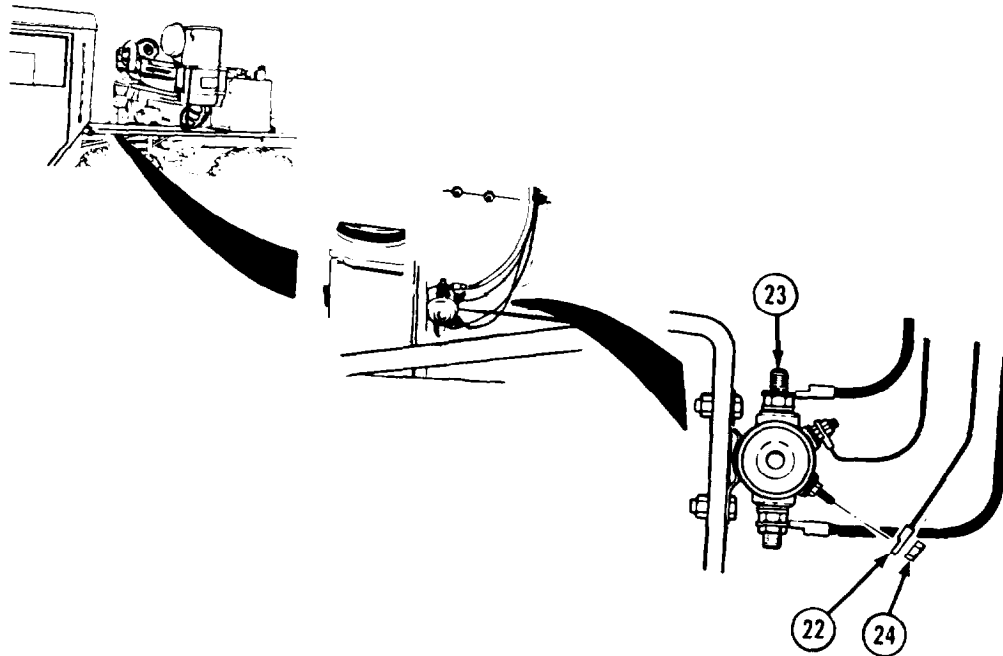

(8) Connect wire (22) to starter solenoid (23) with nut (24).

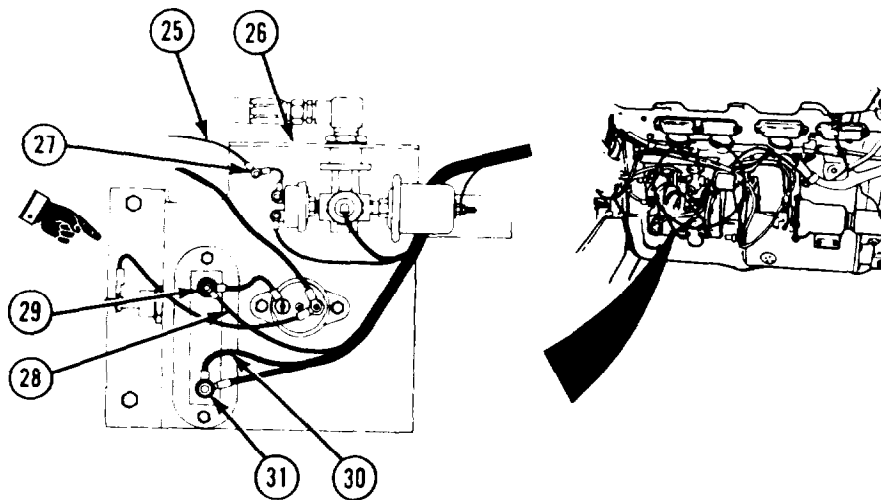

- (9) Connect ether start ground wire (25) to bracket (26) with screw (27).
- (10) Connect wire (28) with screw (29).
- (11) Connect two wires (30) with screw (31).

Electrical System Maintenance Instructions (Cont)

- (12) Connect lead (32) to low engine oil switch (33) with screw (34).
- (13) Connect two wires (35) to low oil pressure switch (36).
- (14) Connect wire (37) to oil pressure sending unit (38) with lockwasher (39) and nut (40).

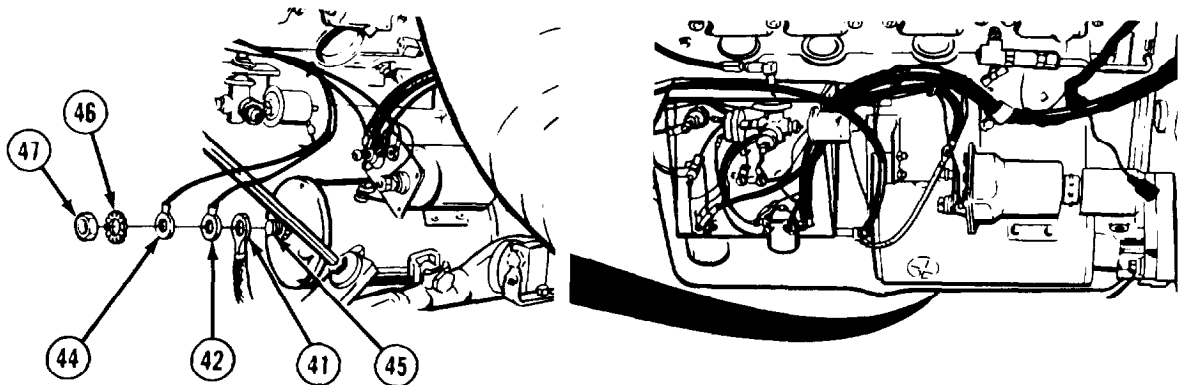
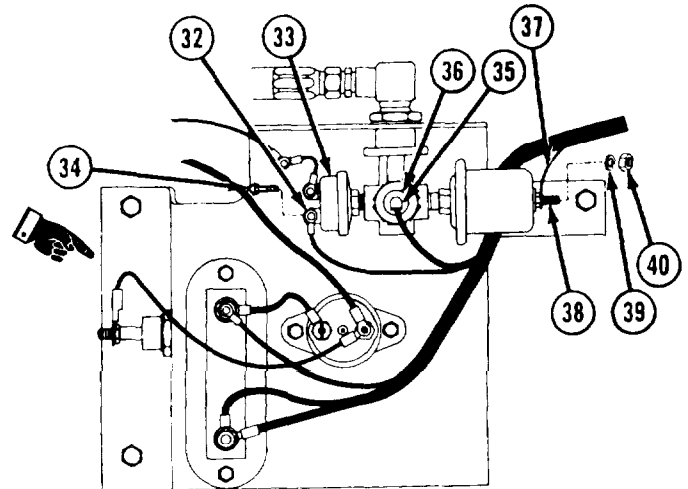

- (15) Connect wire (41) and harness wires (42 and 44) to starter terminal (45) with lockwasher (46) and nut (47).

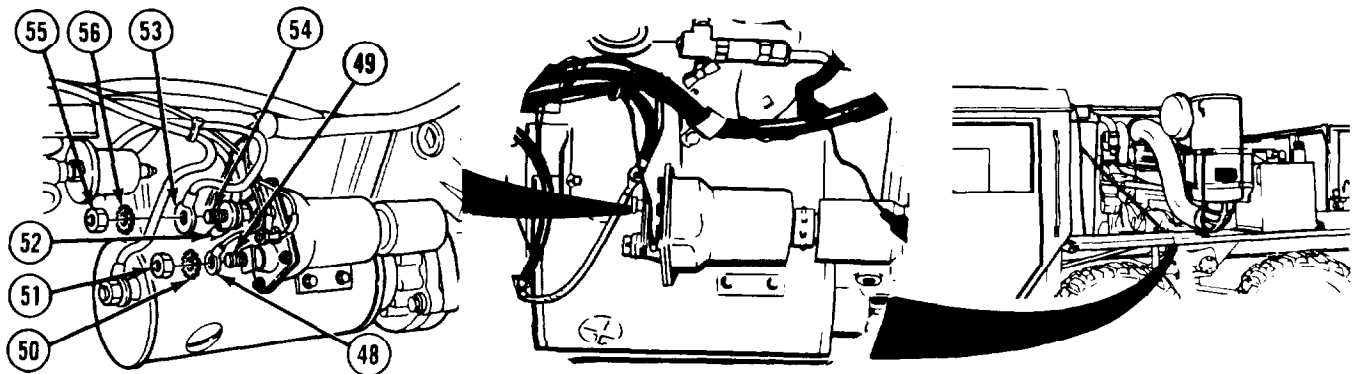

- (16) Connect wire (48) to starter solenoid terminal (49) with washer (50) and nut (51).
- (17) Connect two wires (52 and 53) to starter solenoid terminal (54) with nut (55) and washer (56).

Electrical System Maintenance Instructions (Cont)

6-14. ENGINE WIRING HARNESS REMOVAL/INSTALLATION (CONT).

- (18) Thread two wires (57) to engine shutdown solenoid (58) and connect to shutdown solenoid terminal (59) with two nuts (60).
- (19) Route three wires (61) under engine shutdown solenoid (58) and push slip-on terminals onto terminals of buffer switch (62).

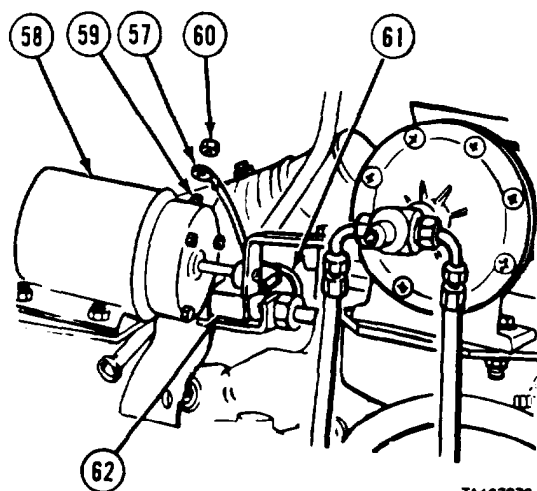

TA187876

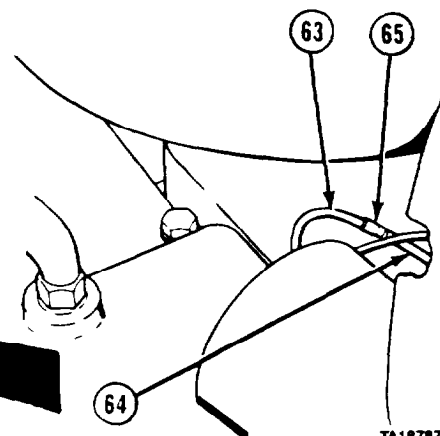
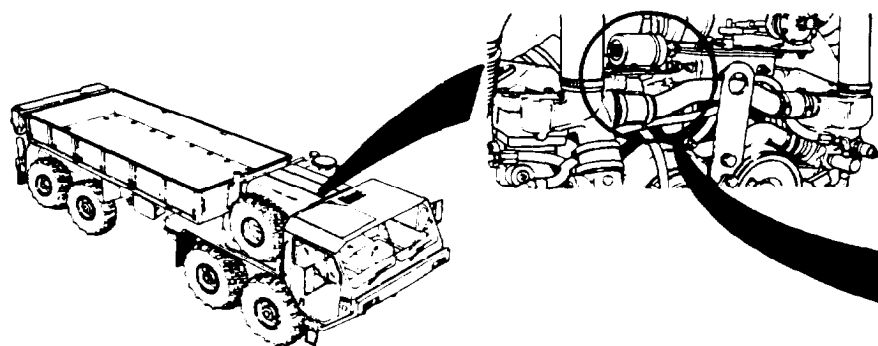

TA187877

- (20) Pull together right engine brake wire (63) and its companion wire (64) from harness. Insert stripped ends of each wire into electrical butt connector (65) and crimp connector to complete splice.

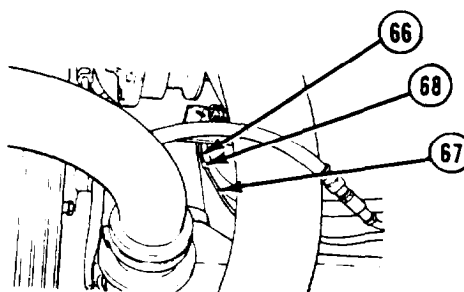
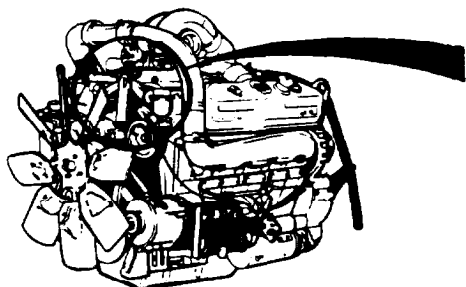

TA187878

- (21) Pull together left engine brake wire (66) and its companion wire (67) from harness. Insert stripped ends of each wire into electrical butt connector (68) and crimp connector to complete splice.

Electrical System Maintenance Instructions (Cont)

- (22) Connect high idle solenoid wire (69) to connector (70).
- (23) Push connector (71) of tachometer sending unit (72) firmly into harness connector (73).

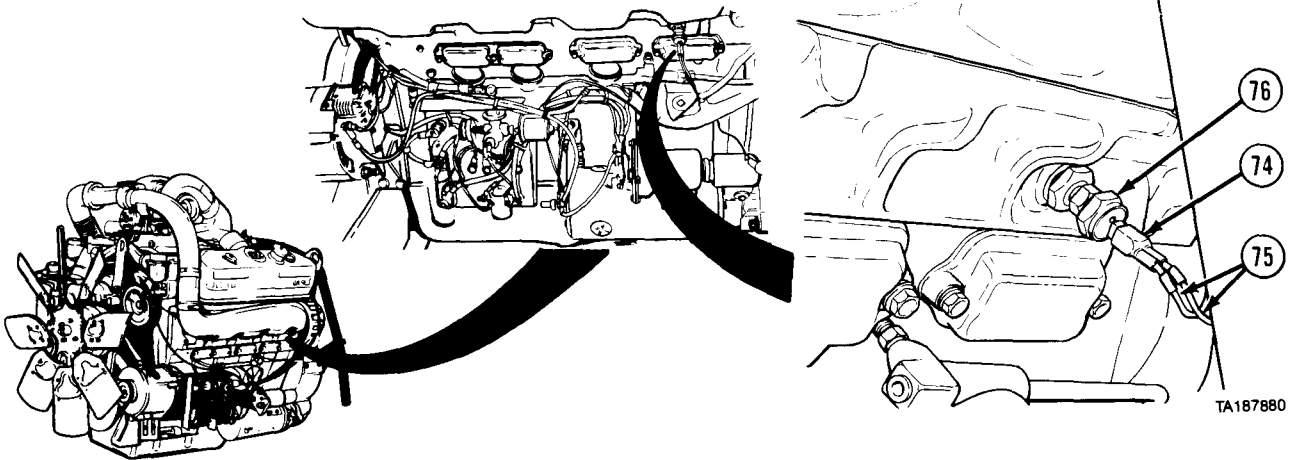
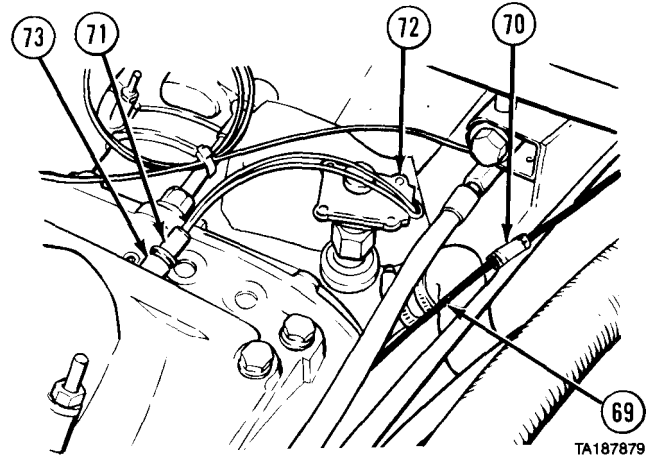

- (24) Connect push-on terminals (74) of two wires (75) to water temperature thermostat (76).

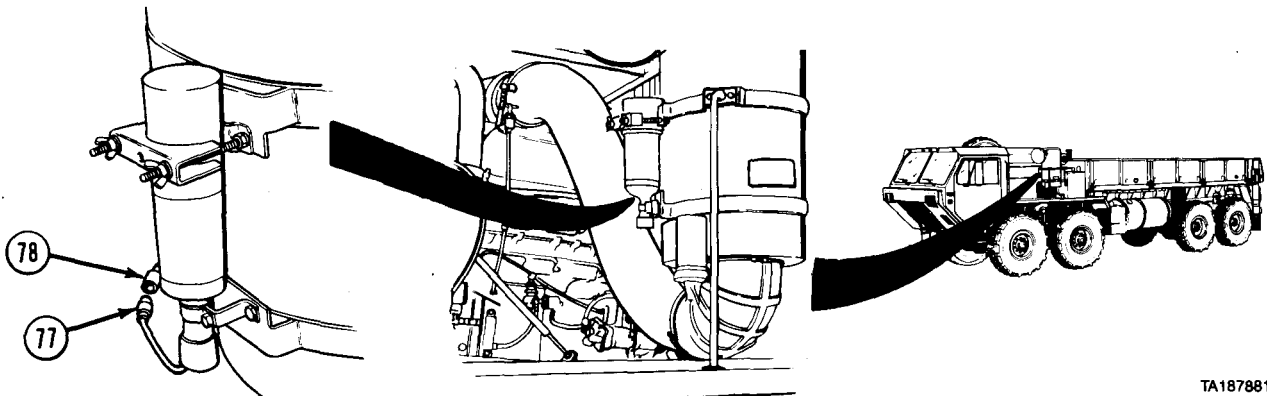

- (25) Connect ether start plug (77) into harness socket (78).

Electrical System Maintenance Instructions (Cont)

6-14. ENGINE WIRING HARNESS REMOVAL/INSTALLATION (CONT).

NOTE

M984E1 does not use this cushion clip.

- (26) Install cushion clip (79) around engine harness (1) and secure cushion clip to flange of transmission (80) with washer (81) and screw (82).

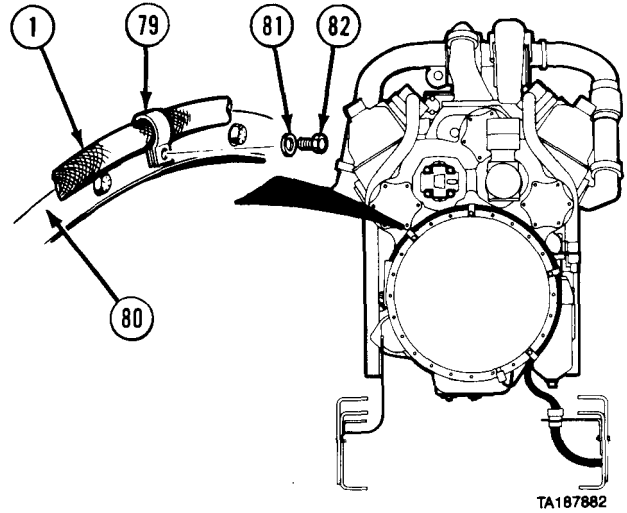

TA187882

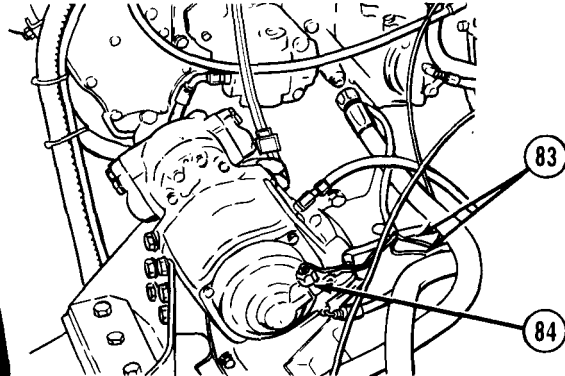
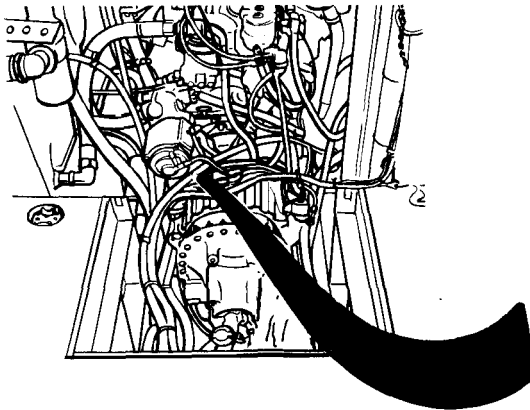

TA187883

NOTE

On M984E1, power takeoff is turned around.

- (27) Connect two wires (83) to power takeoff solenoid (84).

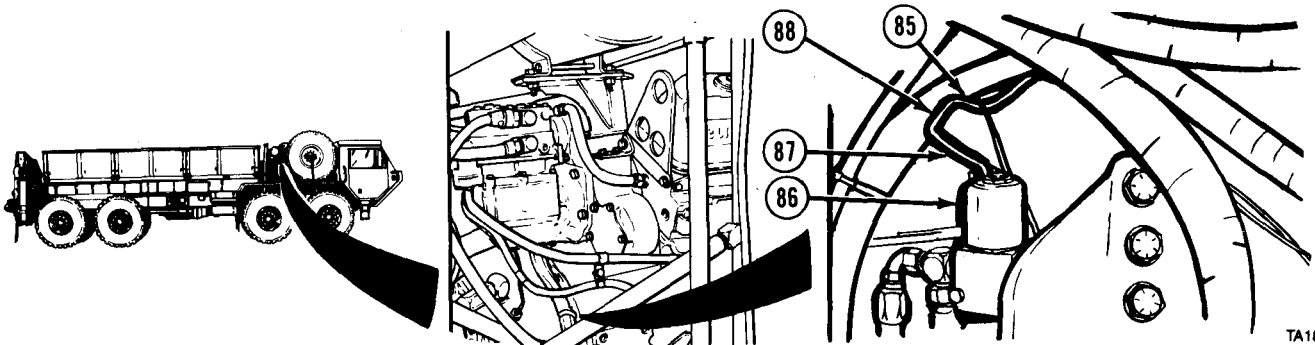

TA187884

- (28) Pull wire (85) from transmission lockup solenoid (86) and harness wire (87) together. Insert stripped ends into electrical butt connector (88) and crimp connector to complete splice.

Electrical System Maintenance Instructions (Cont)

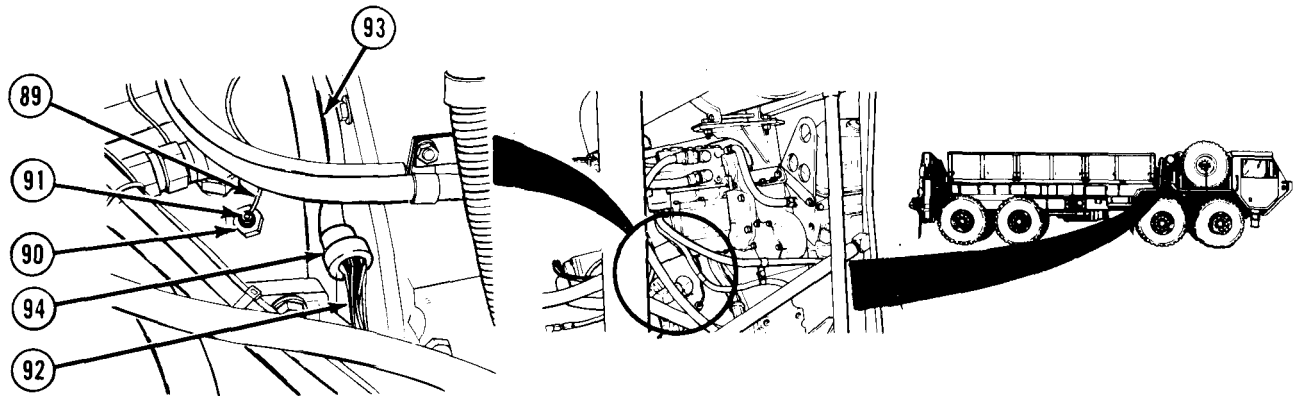

TA187885

- (29) Connect wire (89) to transmission temperature sending unit (90) with nut (91).
- (30) Connect STE/ICE harness (92) and engine harness (93) at connector (94).

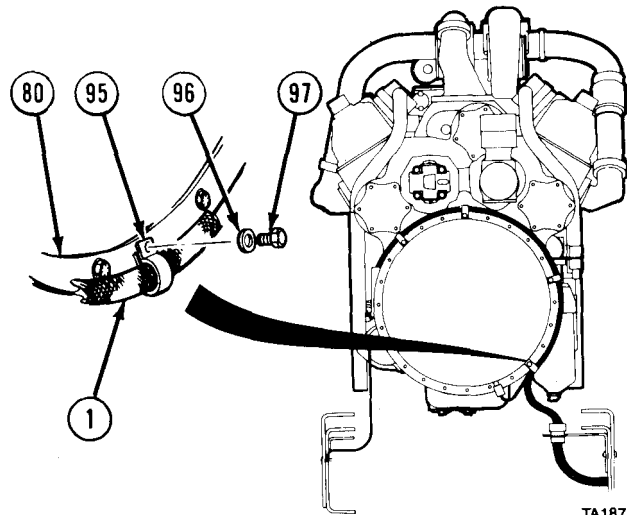

TA187886

NOTE

M984E1 uses two cushion clips.

- (31) Anchor engine harness (1) to lower right flange of transmission (80) with cushion clip (95), washer (96), and screw (97).

c. Follow-on Maintenance.

- (1) Connect batteries (TM 9-2320-279-20).
- (2) Start engine and check operation of engine components (TM 9-2320-279-20).
- (3) Shut off engine (TM 9-2320-279-10).

END OF TASK

Electrical Systems Maintenance Instructions (Cont)

6-15. CHASSIS WIRING HARNESS REMOVAL/INSTALLATION.	
This task covers:	
a. Removal	c. Follow-on Maintenance
b. Installation	
INITIAL SETUP	
<i>Models</i>	<i>References</i>
All except M984E1	None
<i>Test Equipment</i>	<i>Equipment Condition</i>
None	
<i>Special Tools</i>	<i>TM or Para</i>
None	TM 9-2320-279-10 Shut off engine.
	TM 9-2320-279-10 Air system drained.
	TM 9-2320-279-20 Batteries disconnected.
	TM 9-2320-279-20 Work lamps and bracket removed (M984).
<i>Supplies</i>	<i>Special Environmental Conditions</i>
Connector, electrical, butt, Item 31, Appendix C	None
Tags, identification, Item 60, Appendix C	
Tape, insulation, electrical, Item 62, Appendix C	<i>General Safety Instructions</i>
Ties, cable, plastic, Item 65, Appendix C	None
<i>Personnel Required</i>	<i>Level of Maintenance</i>
MOS 63W, Wheel vehicle repairer	Direct Support

a. Removal.

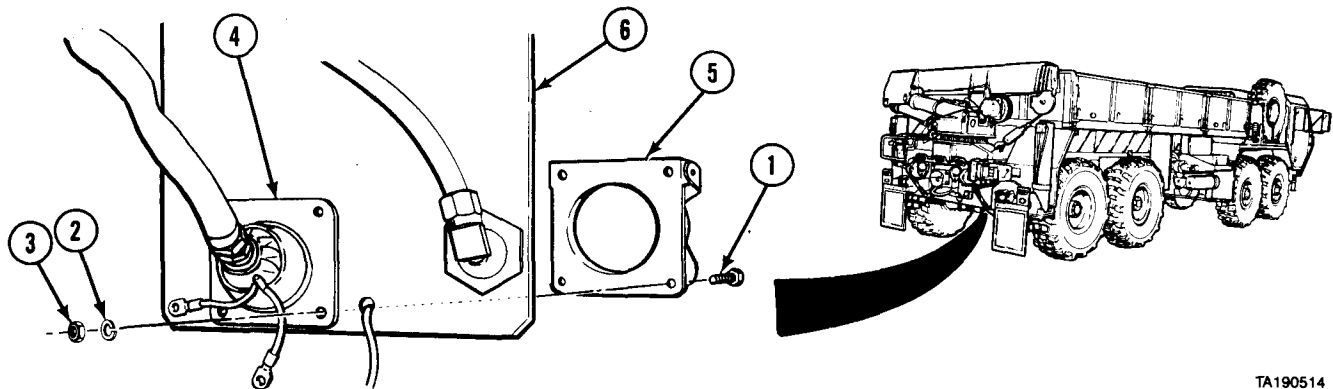

TA190514

NOTE

Tag and mark all wires and connectors.

- (1) Remove four screws (1), lockwashers (2), nuts (3), and trailer electrical connector (4),
- (2) Remove spring cover (5) from mounting bracket (6).

Electrical Systems Maintenance Instructions (Cont)

NOTE

- Remove clamp, cushion clips, and plastic cable ties as necessary.
 - Cushion clips are returned to same positions after section of chassis harness is removed.
- (3) Remove nut (7), lockwasher (8), washer (9), screw (10), and cushion clip (11) from chassis wiring harness (12).

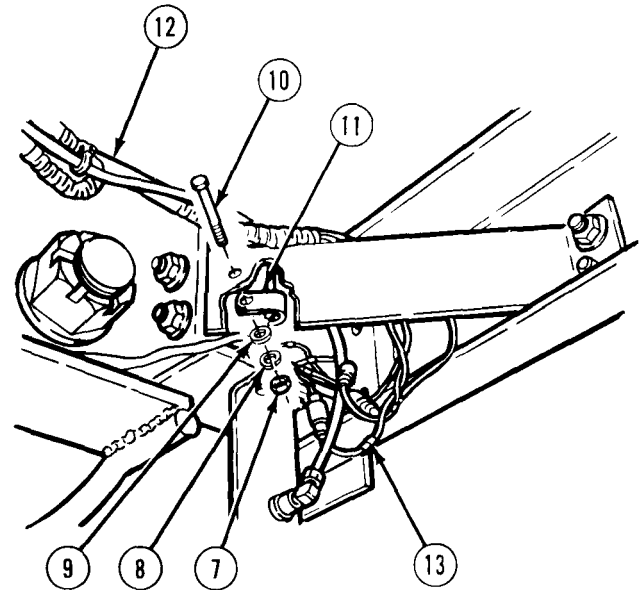

NOTE

Do step (4) for wiring each rear composite light.

- (4) Disconnect four connectors (13).

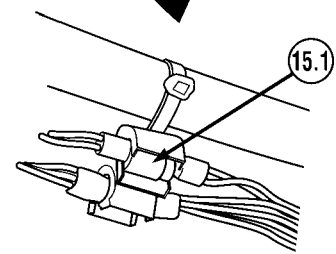
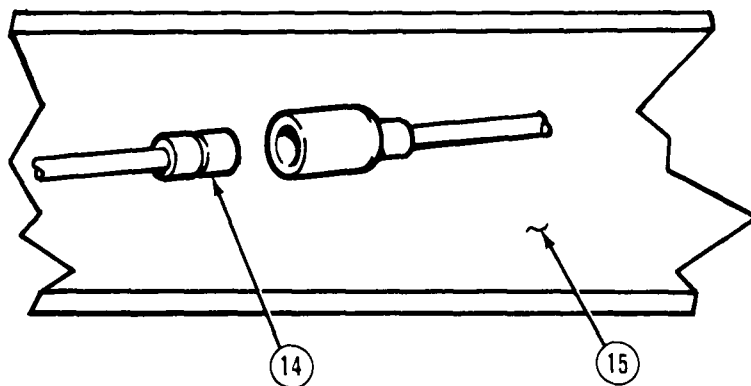
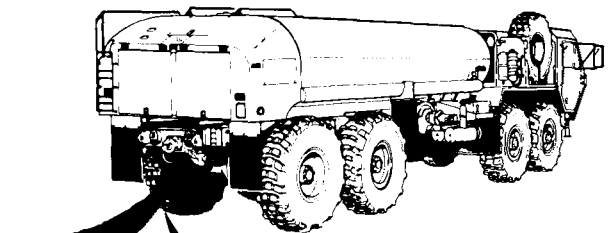

NOTE

- Do step (5) for M978 only.
 - Do step (5.1) for M978 only if equipped with high mount stop light.
- (5) Disconnect tanker module power connector (14) at left rear of frame (15).
- (5.1) Disconnect high mount stop lamp connector (15.1) from under left rear of vehicle.

Electrical Systems Maintenance Instructions (Cont)

6-15. CHASSIS WIRING HARNESS REMOVAL/INSTALLATION (CONT).

NOTE

Do steps (6) through (11) for M977 and M985 only.

- (6) Disconnect 4-pin crane power connector (16).

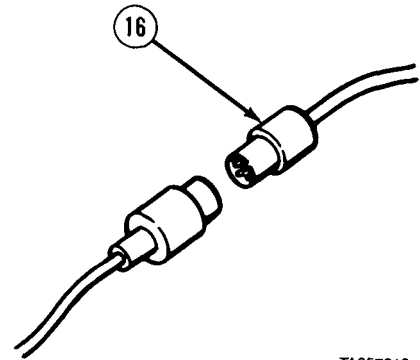
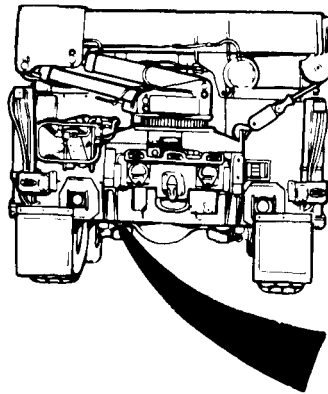

TA357210

NOTE

Left and right clearance light wiring harnesses are removed the same.

- (7) Pull clearance light wiring harness (17) from under subframe (18).
- (8) Open loom (19) and cut chassis wiring harness (12).

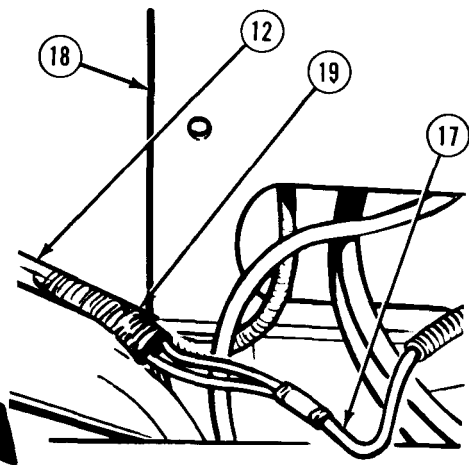
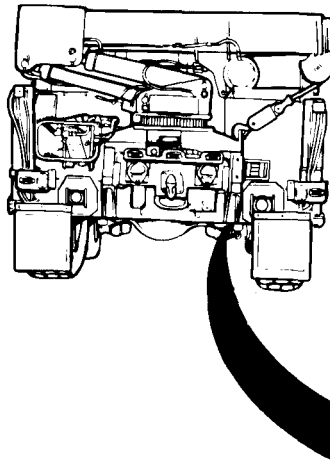

TA357211

- (9) Disconnect locking device (20) from connector (21).
- (10) Disconnect connector (22) from connector (21).
- (11) Pull harness branch (23) down under vehicle.

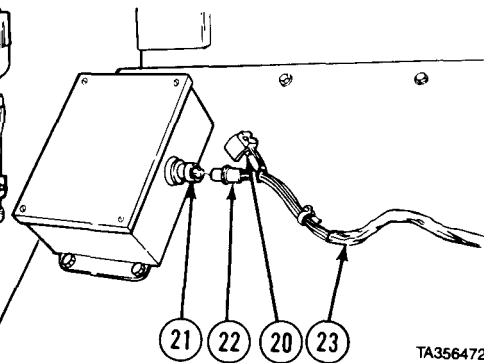
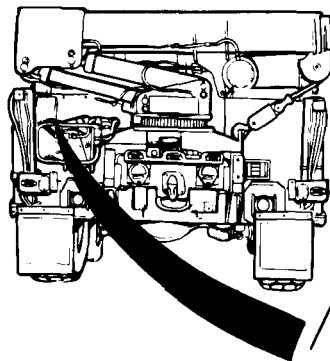

TA356472

Electrical Systems Maintenance Instructions (Cont)

NOTE

Do steps (12) through (16)
M983 only.

- (12) Disconnect clearance light connector (24).
- (13) Disconnect crane power connector (25).
- (14) Push back sleeving (26) and loom (27). Remove connector (28) from harness work light branch (29) and work light wires (30).

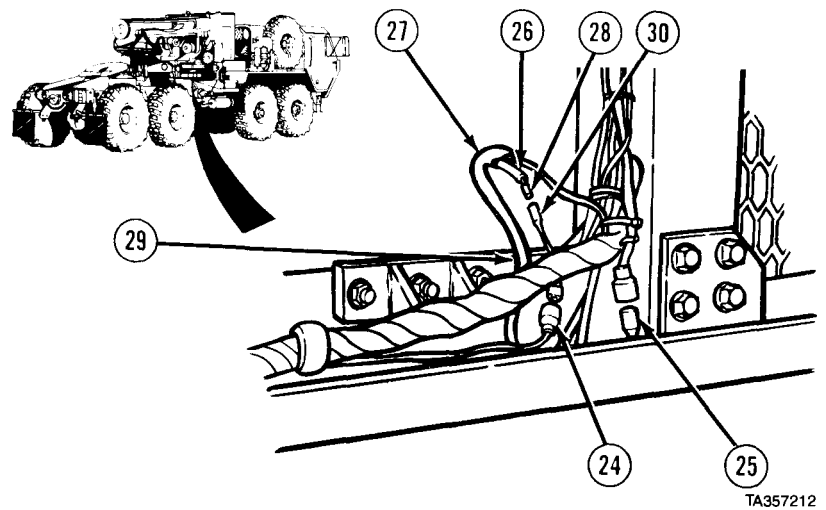

TA357212

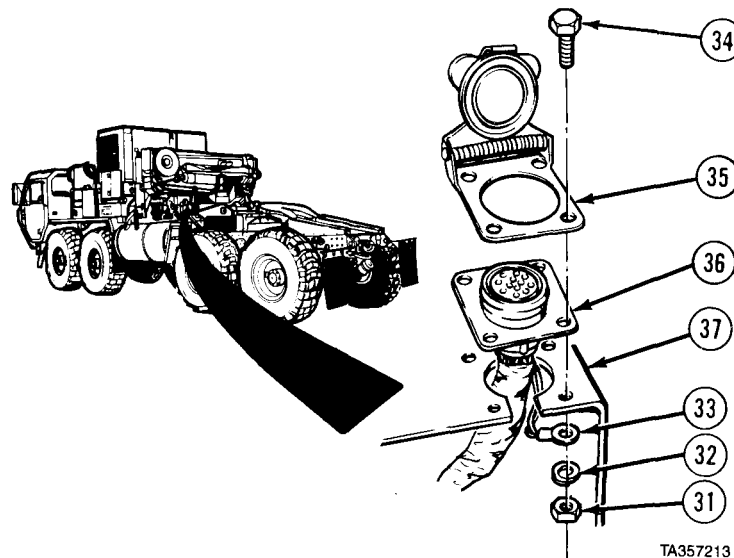

TA357213

NOTE

Ground wire will come free when right-rear screw is removed.

- (15) Remove four nuts (31), lockwashers (32), ground wire (33), and four screws (34).
- (16) Remove spring cover (35) and inter-vehicular connector (36) from mounting bracket (37).

Electrical Systems Maintenance Instructions (Cont)

6-15. CHASSIS WIRING HARNESS REMOVAL/INSTALLATION (CONT).

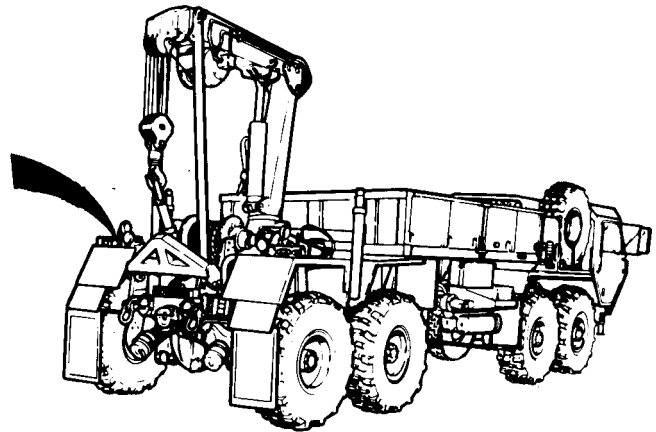
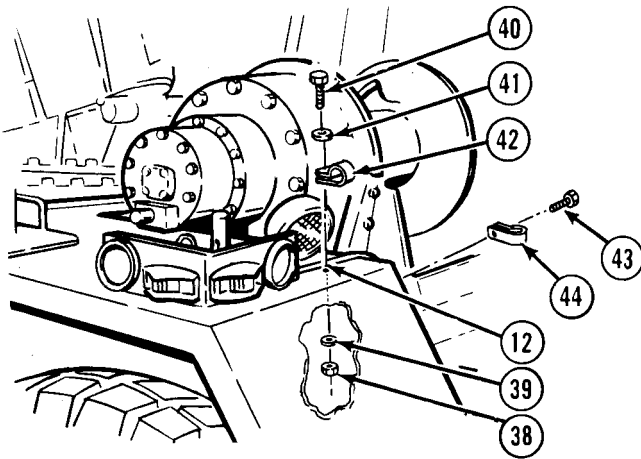

TA190504

NOTE

Do steps (17) and (18) on each side of M984 only.

- (17) Remove three nuts (38), lockwashers (39), screws (40), washers (41), three cushion clips (42), and chassis wiring harness (12).
- (18) Remove two screws (43), cushion clips (44), and chassis wiring harness (12).

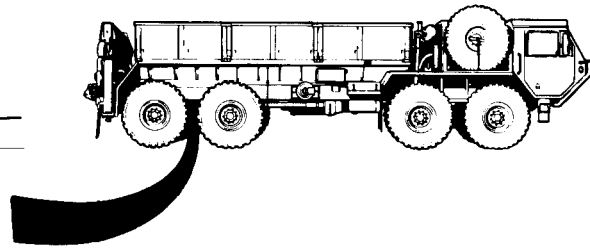
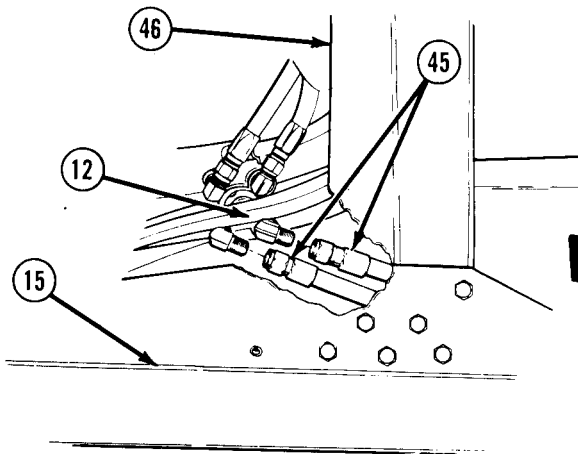

TA190503

NOTE

∩ Chassis wiring harness is attached to crossmembers on frame.

∩ Harness cable is removed from rear between frame and body toward engine.

- (19) Remove two brake lines (45) and pull chassis wiring harness (12) between crossmember (46) and frame (15).

Electrical System Maintenance Instruction (CONT)

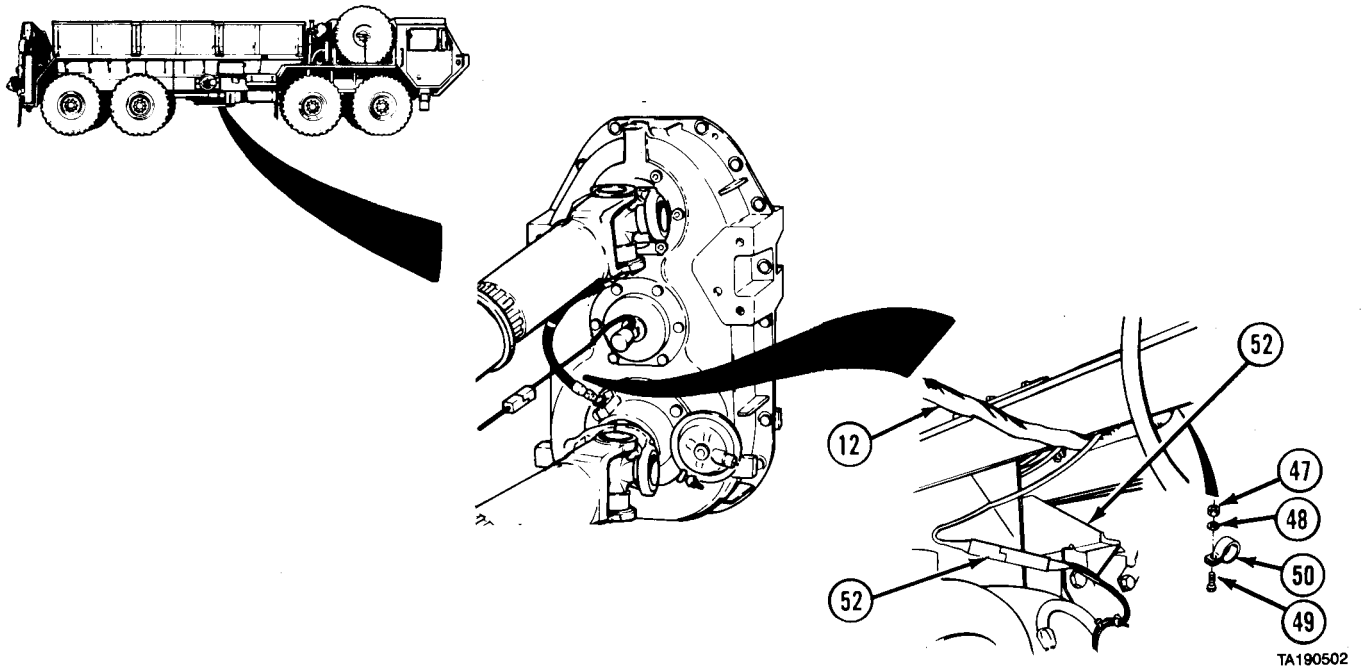

(20) Remove nut (47), lockwasher (48), screw (49), and cushion clip (50).

NOTE

Trailer electrical connector on chassis wiring harness must be turned sideways to fit through transfer case mount.

(21) Pull chassis wiring harness (12) through transfer case mount (51).

(22) Remove tape from speedometer cable plug (52) and disconnect wiring harness (12).

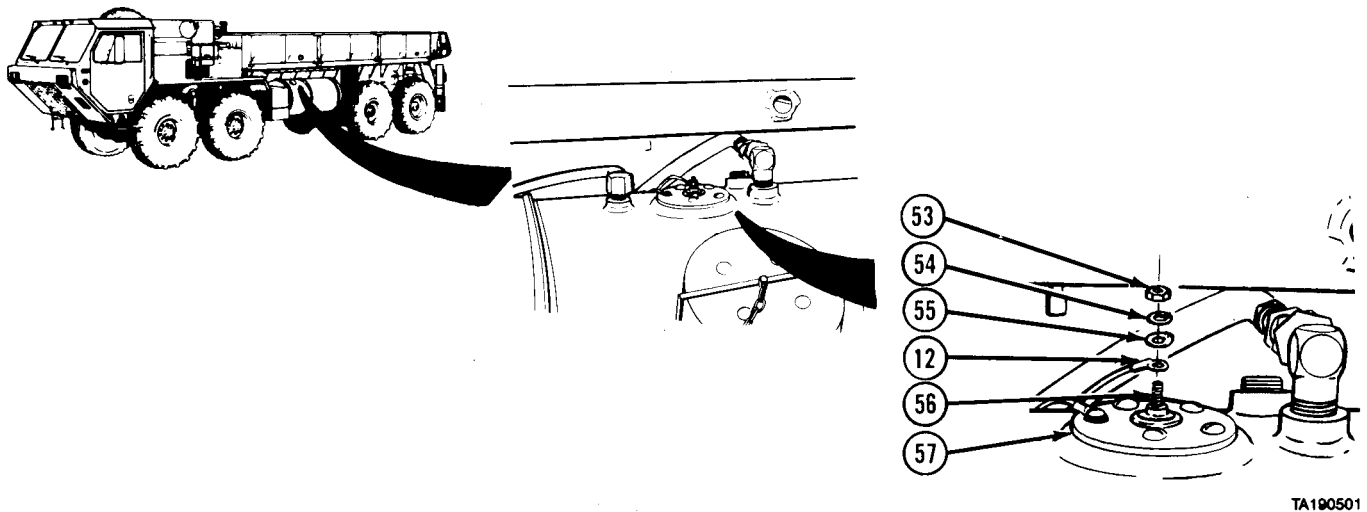

(23) Remove nut (53), lockwasher (54), washer (55), chassis wiring harness (12) from stud (56) on fuel level sending unit (57).

Electrical Systems Maintenance Instructions (Cont)

6-15. CHASSIS WIRING HARNESS REMOVAL/INSTALLATION (CONT).

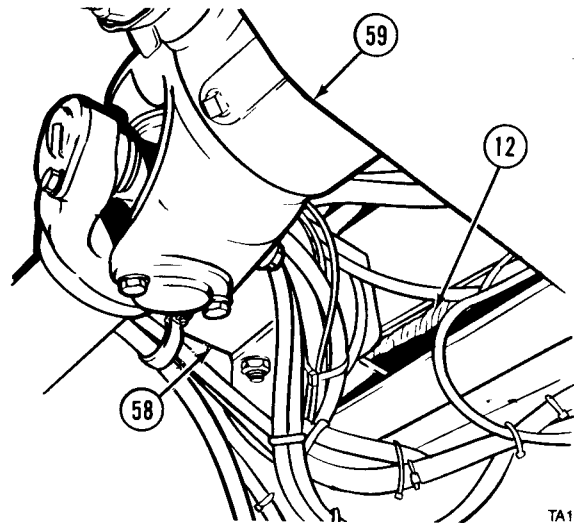
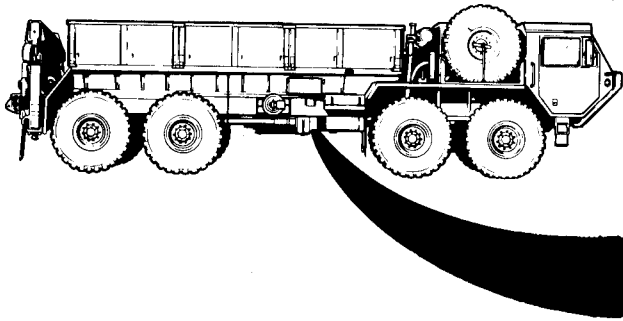

TA190500

NOTE

Chassis wiring harness cable cannot move past transfer case front crossmember. Trailer electrical connector at end of cable will not fit through clearance.

- (24) Pull chassis wiring harness (12) up to crossmember (58) in front of transfer case (59).

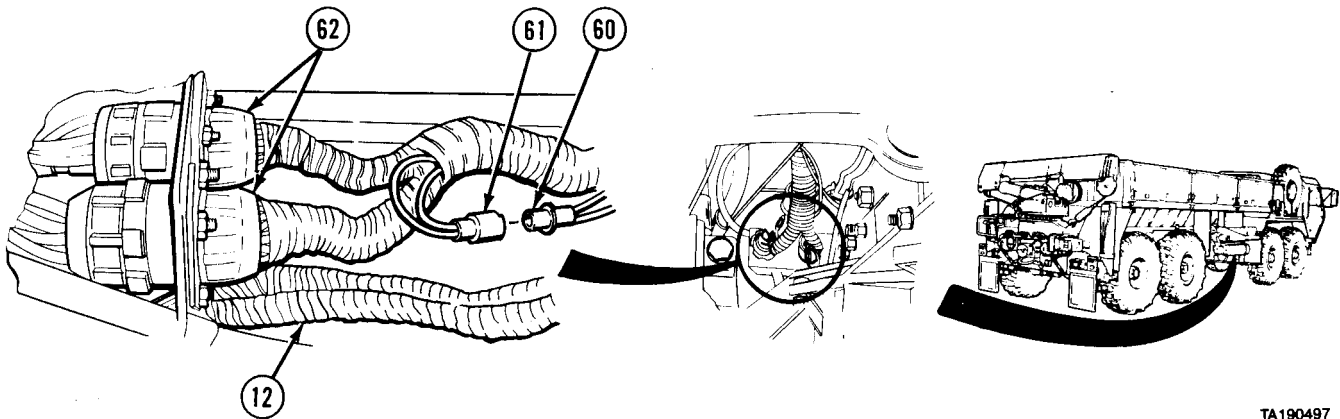

TA190497

NOTE

All cushion clips, plastic cable ties, and hardware from chassis harness must be removed to pull chassis harness through frame.

- (25) Disconnect chassis harness plug (60) from engine harness plug (61) at engine harness connectors (62).
- (26) Pull chassis wiring harness (12) through cab and frame up to engine harness connectors (62).

Electrical Systems Maintenance Instructions (Cont)

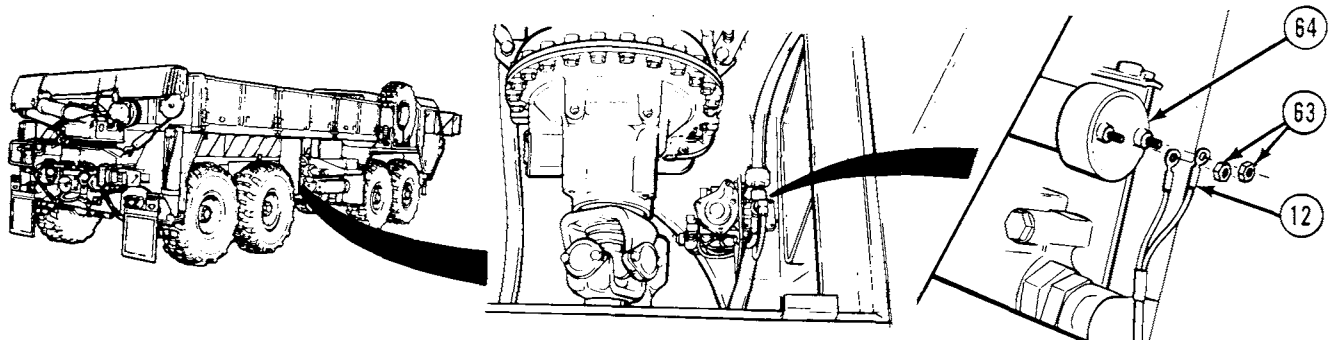

(27) Remove two nuts (63) and chassis wiring harness (12) from towing brake pressure switch (64).

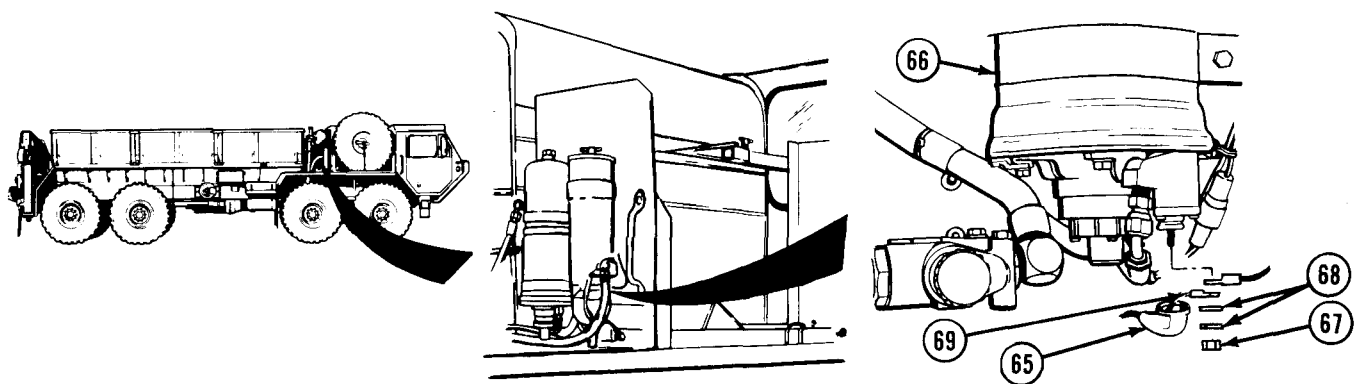

(28) Pull back rubber boot (65) on air dryer (66).

NOTE

- M983 with crane has three wires.
- Do step (29.1) for M978 only if equipped with high mount stop light.

(29) Remove nut (67), two lockwashers (68), and two wires (69).

(29.1) Disconnect connector (69.1) from connector (69.2).

(30) Remove chassis harness connector (70) from receptacle (71) under cab floor (72).

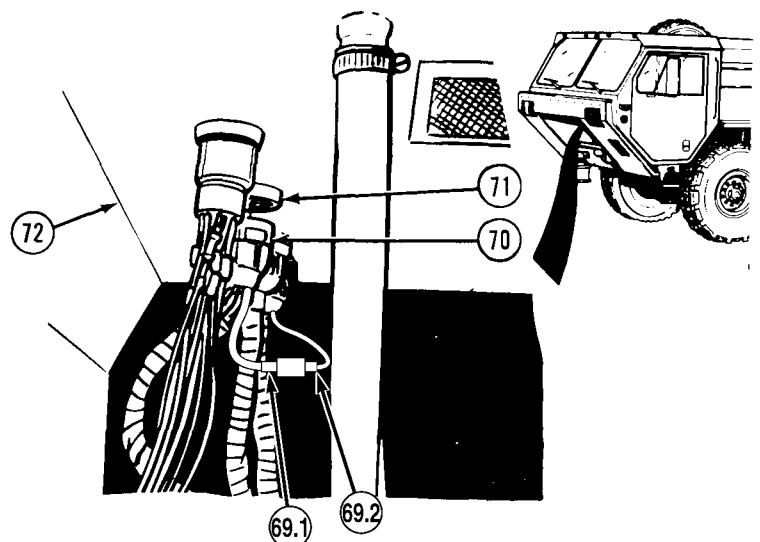

Electrical Systems Maintenance Instructions (Cont)

6-15. CHASSIS WIRING HARNESS REMOVAL/INSTALLATION (CONT).

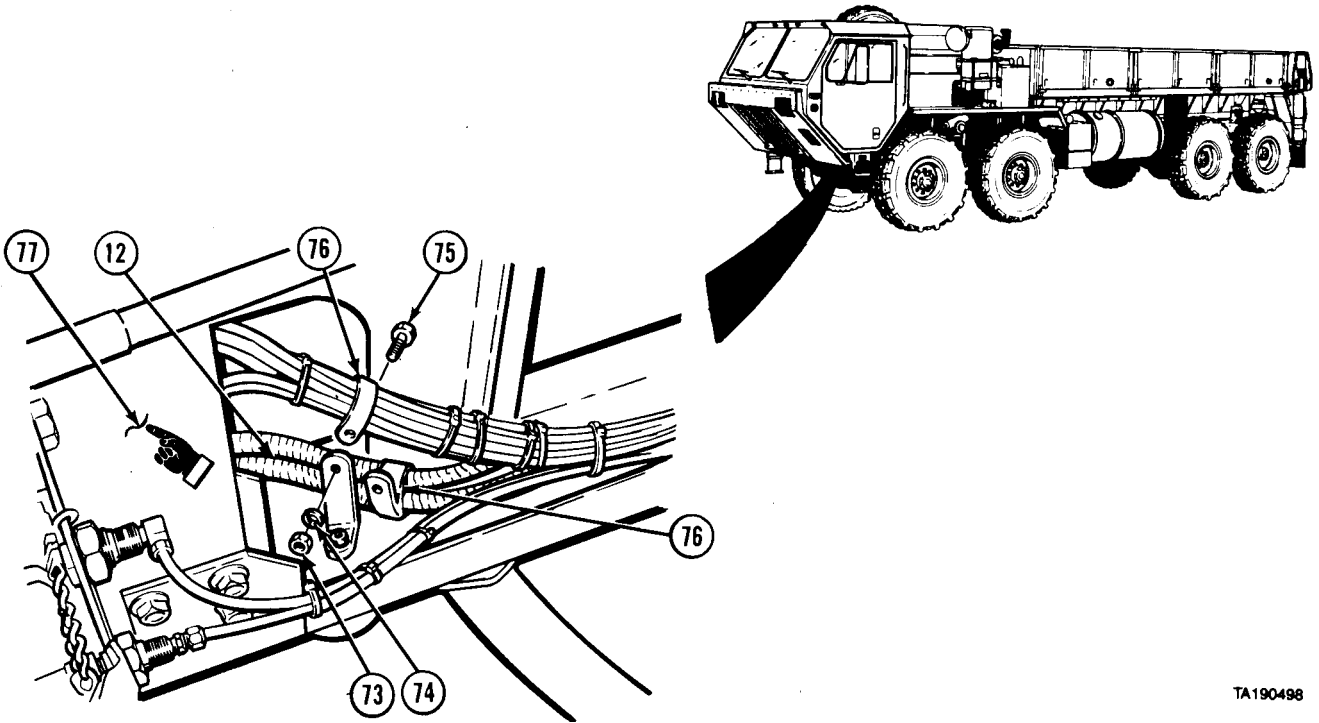

TA190498

- (31) Remove nut (73), lockwasher (74), screw (75), and two cushion clips (76).
- (32) Pull chassis wiring harness (12) out from cab (77).

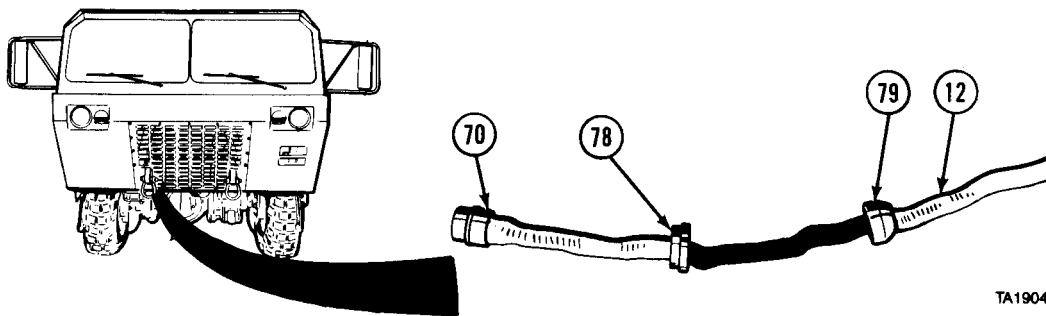

TA190494

- (33) Loosen lockring (78) and back shell (79) from chassis harness connector (70).
- (34) Push back shell (79) and lockring (78) down chassis wiring harness (12) and pull harness from vehicle.

Electrical Systems Maintenance Instructions (Cont)

b. Installation.

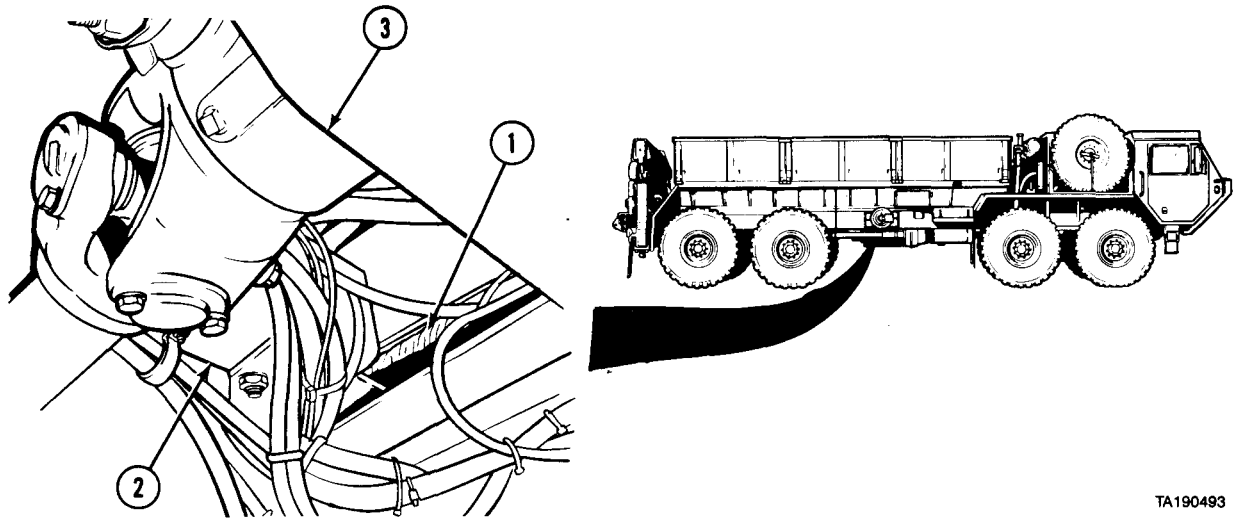

TA190493

(1) Insert chassis wiring harness (1) through crossmember (2) at transfer case (3).

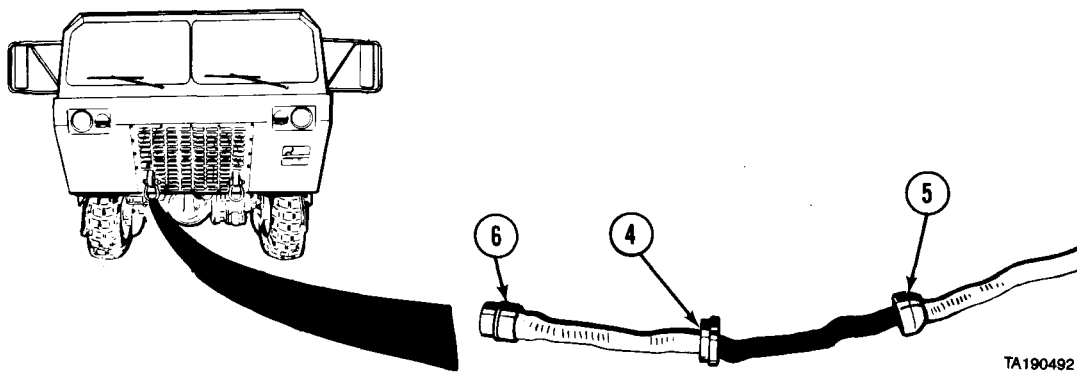

TA190492

(2) Install locking (4) and back shell (5) on chassis harness connector (6).

Electrical Systems Maintenance Instructions (Cont)

6-15. CHASSIS WIRING HARNESS REMOVAL/INSTALLATION (CONT).

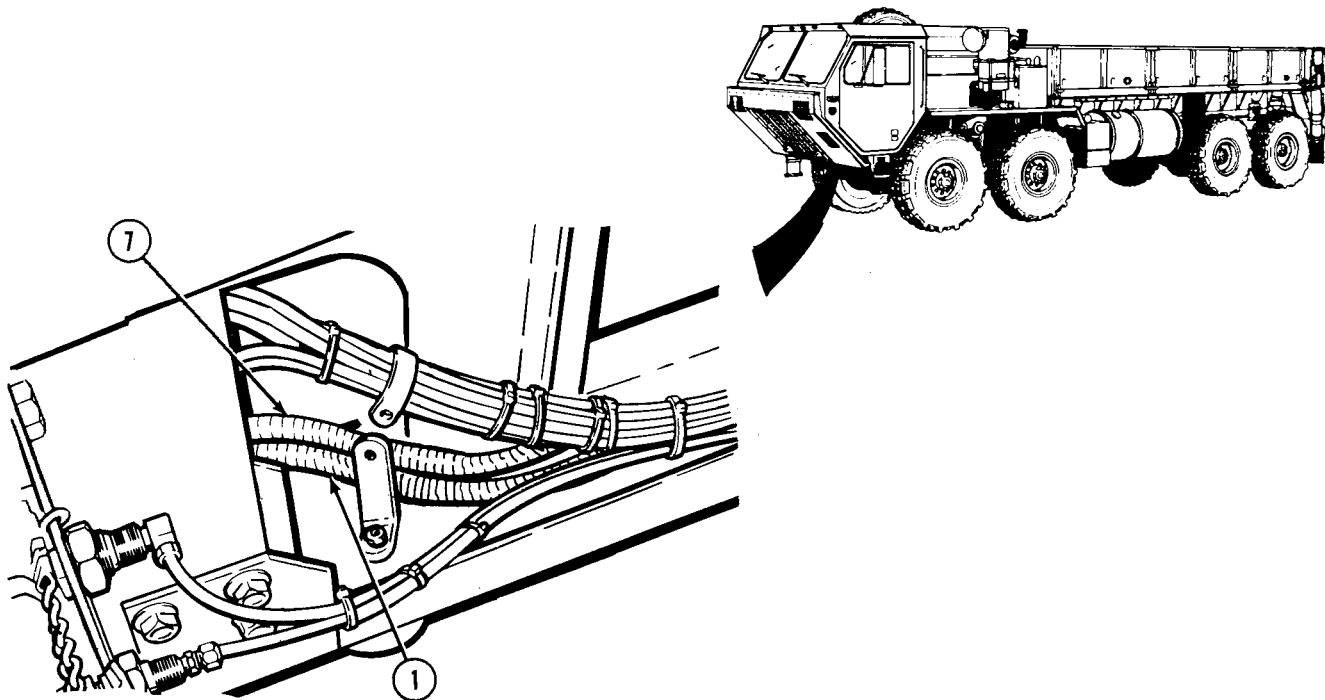

(3) Route chassis wiring harness (1) up under cab beside chassis/engine harness (7).

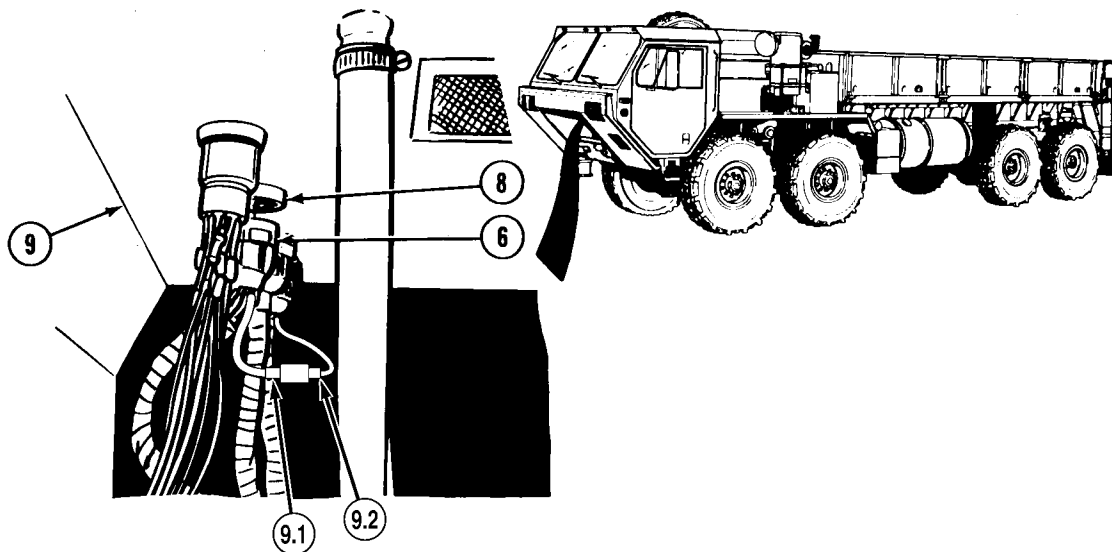

NOTE

Do step (4.1) for M978 only if equipped with high mount stop light.

(4) Connect chassis harness connector (6) to receptacle (8) under cab floor (9).

(4.1) Connect connector (9.1) to connector (9.2).

Electrical Systems Maintenance Instructions (Cont)

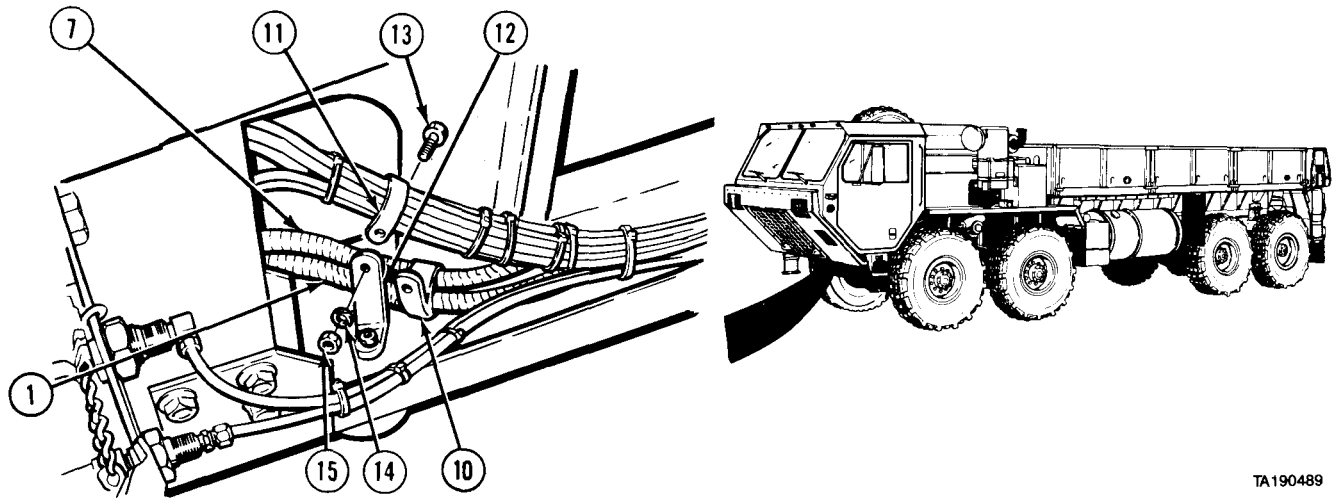

TA190489

NOTE

Wrap chassis wiring harness to other wiring with plastic cable ties.

- (5) Install chassis wiring harness (1) into cushion clip (10) with chassis/engine harness (7).
- (6) Install cushion clips (10 and 11) to bracket (12) with screw (13), lockwasher (14), and nut (15).

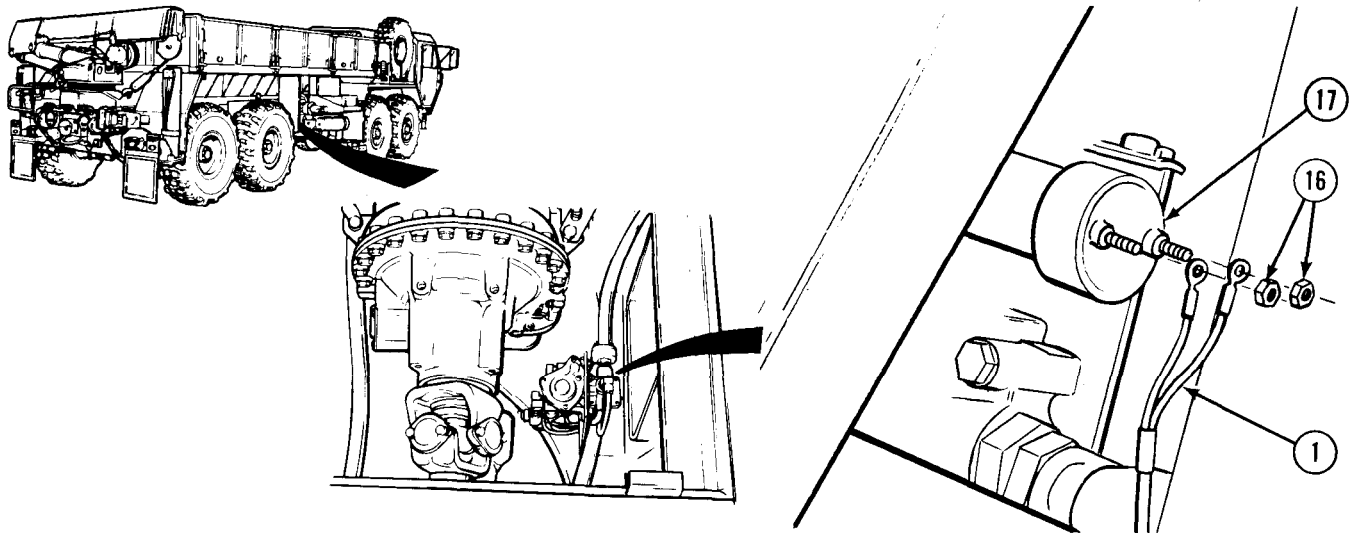

TA190488

- (7) Install chassis wiring harness (1) and two nuts (16) to towing brake pressure switch (17).

Electrical Systems Maintenance Instructions (Cont)

6-15. CHASSIS WIRING HARNESS REMOVAL/INSTALLATION (CONT).

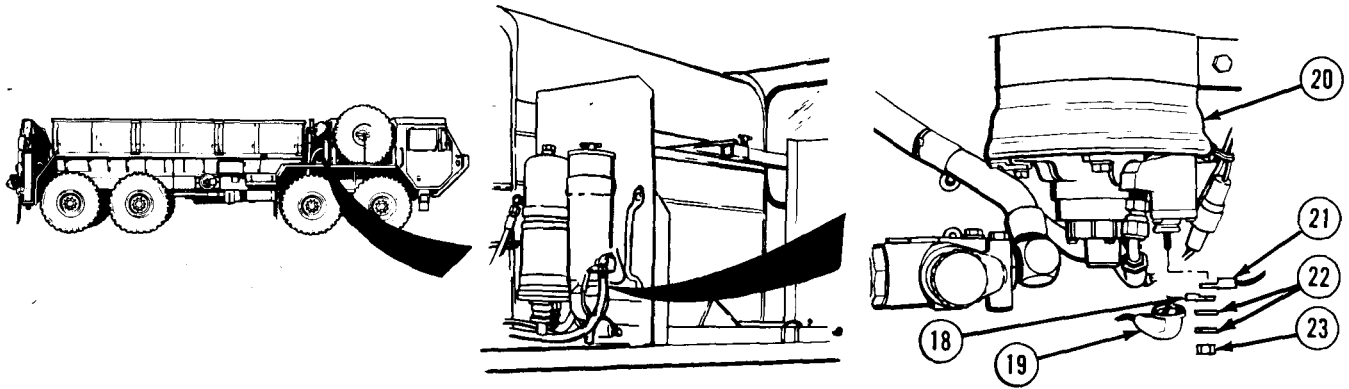

TA190487

NOTE

On M983 with crane, an additional wire attaches to air dryer.

- (8) Insert two wires (18) through rubber boot (19) and install to air dryer (20) with fuel-water separator wire (21), two lockwashers (22), and nut (23).

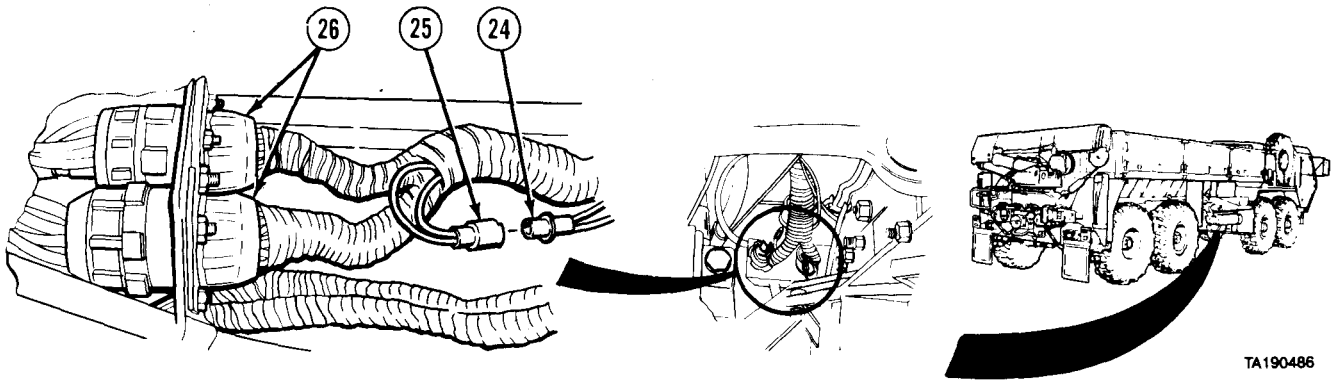

TA190486

- (9) Connect chassis harness plug (24) to engine harness plug (25) at engine harness connectors (26).

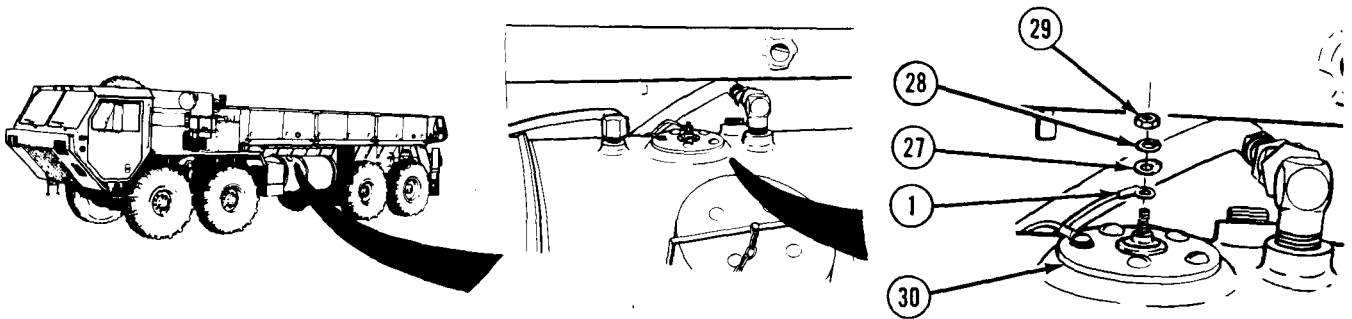

TA190485

- (10) Install chassis wiring harness (1), washer (27), lockwasher (28), and nut (29) on fuel level sending unit (30).

Electrical Systems Maintenance Instructions (Cont)

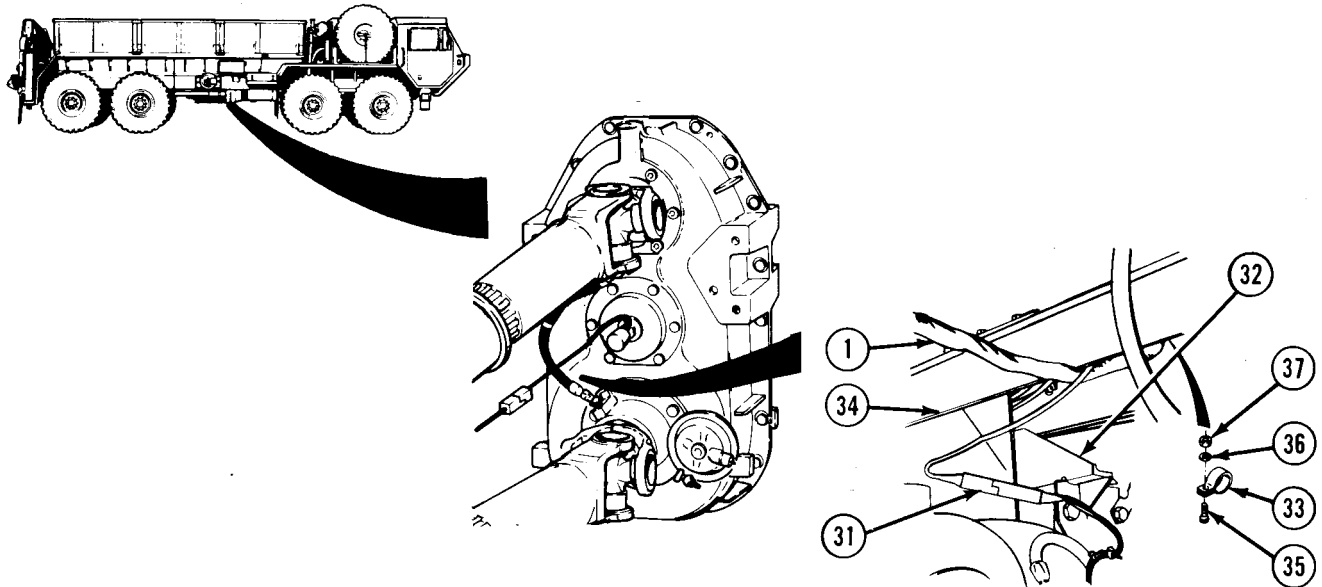

TA190507

- (11) Connect chassis wiring harness (1) to speedometer cable plug (31) and wrap with electrical tape.
- (12) Pull chassis wiring harness (1) through transfer case mount (32).
- (13) Install cushion clip (33) to chassis wiring harness (1) and attach to frame (34) with screw (35), lockwasher (36), and nut (37).

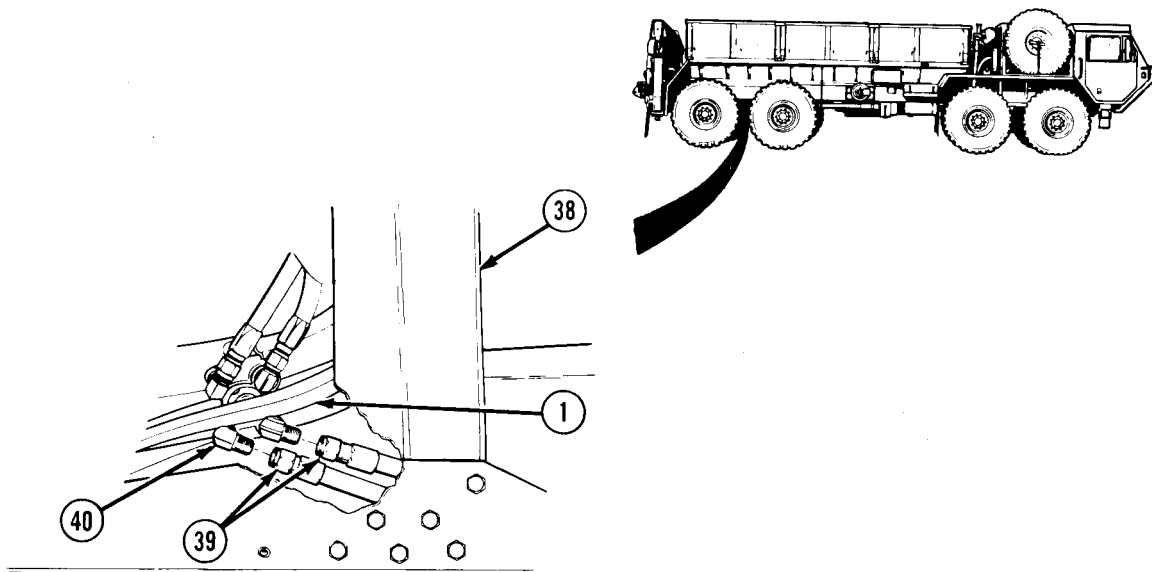

TA190508

- (14) Route chassis wiring harness (1) to rear crossmember (38).
- (15) Install two brake lines (39) to fittings (40).

Electrical Systems Maintenance Instructions (Cont)

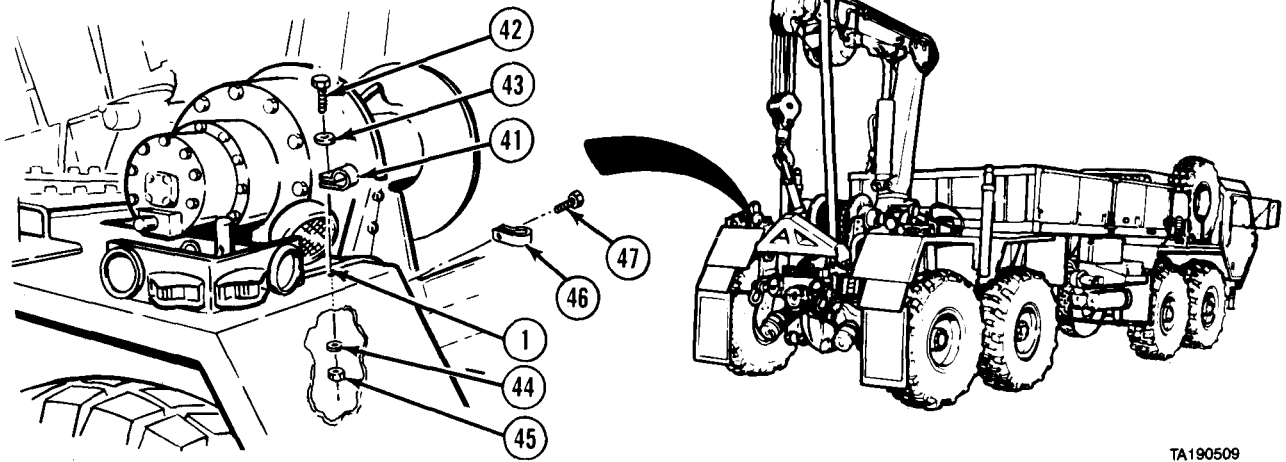

TA190509

NOTE

Do steps (16) and (17) on each side of M984 only.

- (16) Install three cushion clips (41) and chassis wiring harness (1) with three screws (42), washers (43), lockwashers (44), and nuts (45).
- (17) Install two cushion clips (46) and chassis wiring harness (1) with two screws (47).

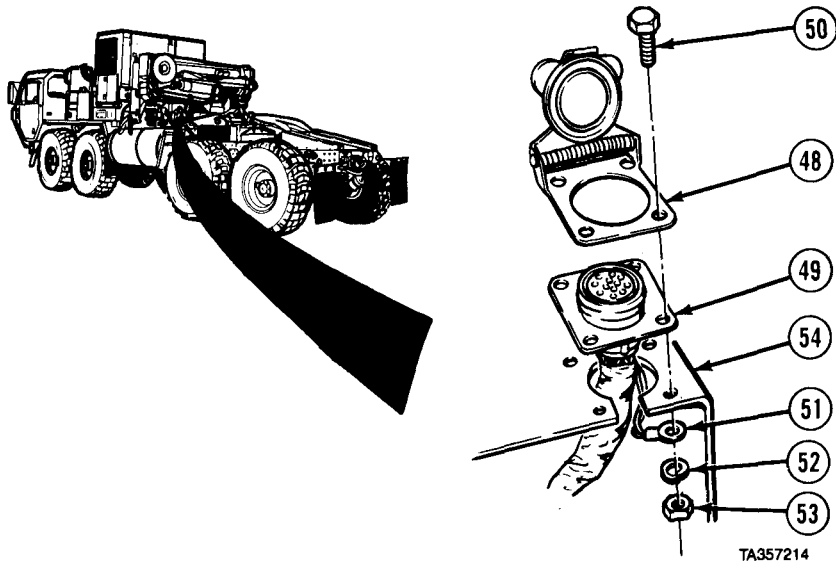

TA357214

NOTE

- Do steps (18) through (21) for M983 only.
- Ground wires are installed on right-rear screw.

- (18) Install spring cover (48), inter-vehicular connector (49), four screws (50), two wires (51), four lockwashers (52), and nuts (53) on mounting bracket (54).

Electrical Systems Maintenance Instructions (Cont)

- (19) Connect work light wires (55) to harness work light branch (56) with connector (57). Cover connector with sleeving (58) and loom (59).
- (20) Connect crane power connector (60).
- (21) Connect clearance light connector (61).

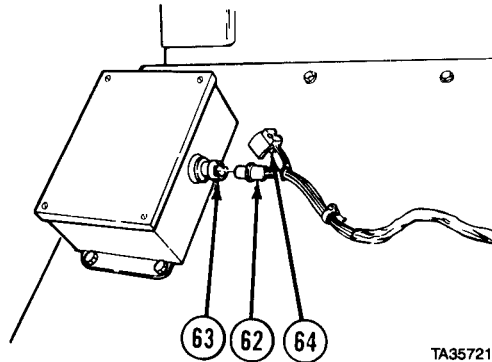
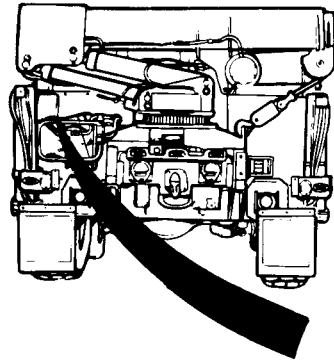
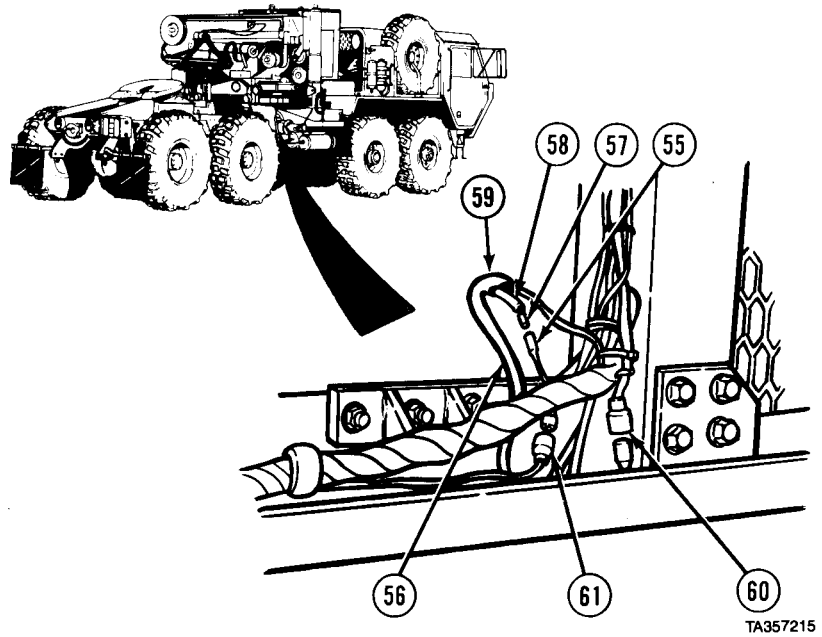

NOTE

Do steps (22) through (26) for M977, M985 only.

- (22) Connect connector (62) to connector (63).
- (23) Connect locking device (64) to connector (63).

Electrical Systems Maintenance Instructions (Cont)

6-15. CHASSIS WIRING HARNESS REMOVAL/INSTALLATION (CONT).

NOTE

Left and right clearance light wiring harnesses are installed the same.

- (24) Connect clearance light wiring harness (65) with electrical butt connector (66).
- (25) Close loom (67) over clearance light wiring harness (65).

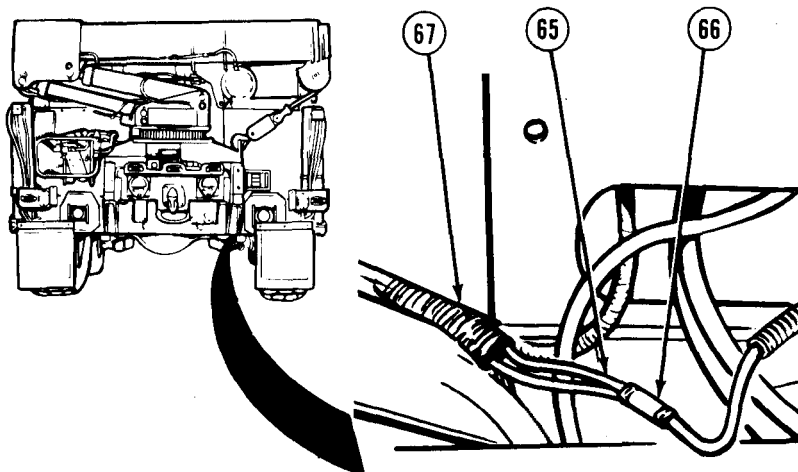

- (26) Connect 4-pin crane power connector (68).

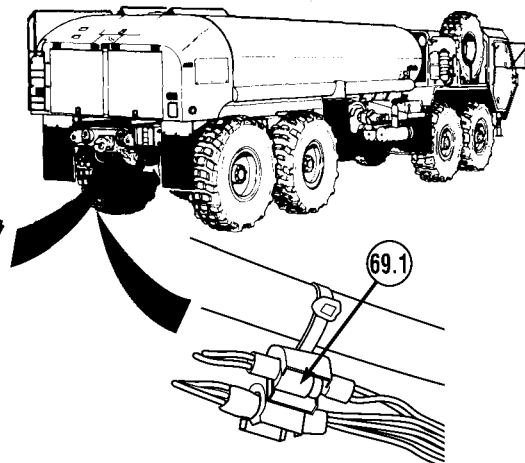
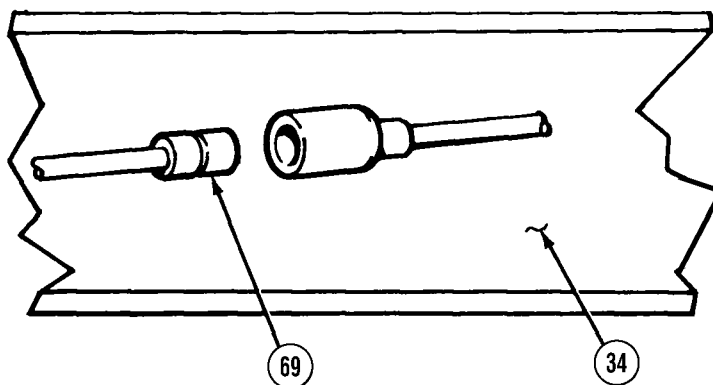
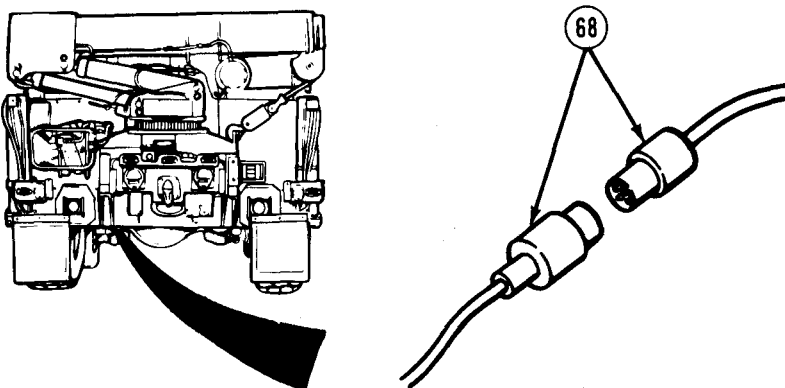

NOTE

- Do step (27) for M978 only.
 - Do step (27.1) for M978 only if equipped with high mount stop light.
- (27) Connect tanker module power connector (69) at left rear of frame (34).
 (27.1) Connect high mount stop lamp connector (69.1) under left rear of vehicle.

Electrical Systems Maintenance Instructions (Cont)

NOTE

Do step (28) for each rear composite light wiring.

(28) Connect four connectors (70).

NOTE

Install all cushion clips to harness.

(29) Install cushion clip (71) and chassis wiring harness (1) to crossmember bracket (72) with screw (73), washer (74), lockwasher (75), and nut (76).

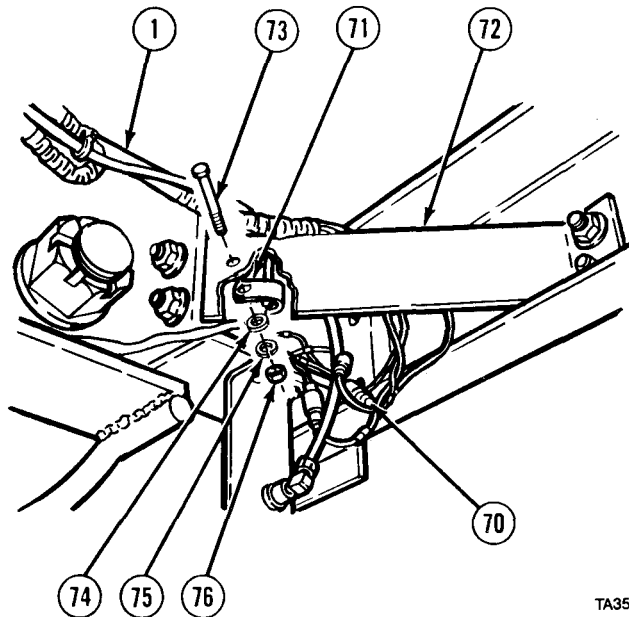

TA357220

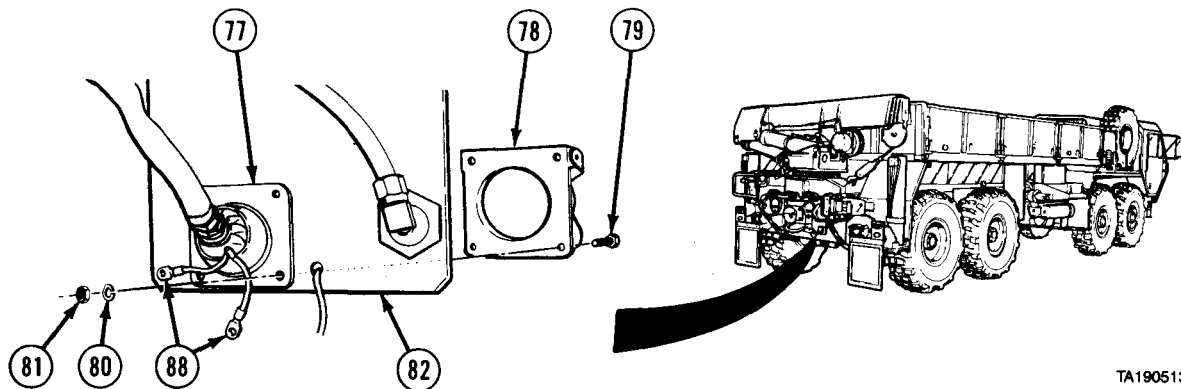

TA190513

NOTE

Leave lower left hole in connector unfastened. Ground wires will be attached to this hole.

(30) Install trailer electrical connector (77) and spring cover (78) with three screws (79), lockwashers (80), and nuts (81) to bracket (82).

(31) Install two ground wires (83) with remaining screw (79), lockwasher (80), and nut (81).

c. Follow-on Maintenance.

(1) Install work lamps and bracket (TM 9-2320-279-20) (M984 only).

(2) Connect batteries (TM 9-2320-279-20).

END OF TASK

Electrical System Maintenance (Cont)

6-15.1. CHASSIS WIRING HARNESS REMOVAL/INSTALLATION (M984E1).

This task covers:

- a. Removal
- b. Installation
- c. Follow-on Maintenance

INITIAL SETUP

Models

M984E1

Test Equipment

None

Special Tools

None

Supplies

Tags, identification, Item 60, Appendix C
 Tape, insulation, electrical, Item 62, Appendix C
 Ties, cable, plastic, Item 65, Appendix C

Personnel Required

MOS 63W, Wheel vehicle repairer

References

None

Equipment Condition

<i>TM or Para</i>	<i>Condition Description</i>
TM 9-2320-279-20	Batteries disconnected.
TM 9-2320-279-20	Skid plate grille removed.

Special Environmental Conditions

None

General Safety Instructions

None

Level of Maintenance

Direct Support

a. Removal.

NOTE

Tag and mark all wires and connectors. Remove all ties and clamps as necessary.

- (1) Remove four nuts (1), two lockwashers (2), wires (3), three lockwashers (4), four screws (5), and trailer electrical connector cover (6) and trailer electrical connector (7).

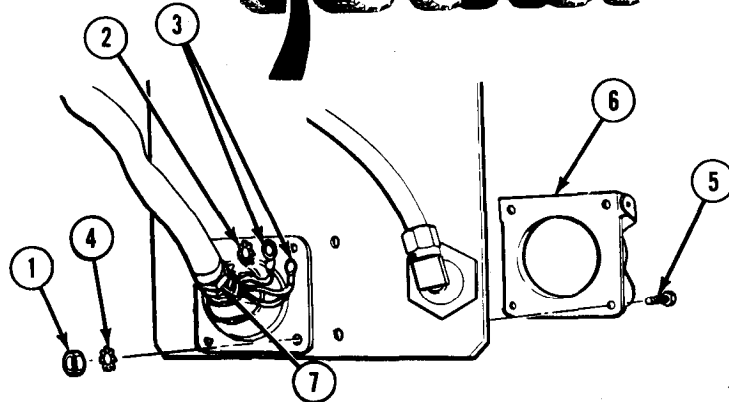
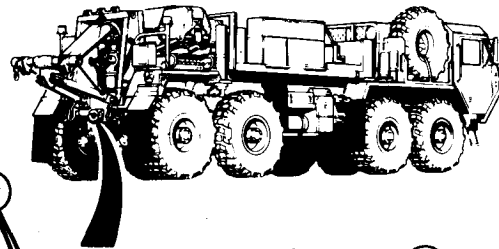

TA476408

Electrical System Maintenance (Cont)

NOTE

Do steps (2) through (6) for right and left rear clearance light and taillight wires. Right rear shown.

- (2) Remove three screws (8), nuts (9) lockwashers (10), and cover (11).
- (3) Disconnect clearance light wire (12). Remove wire from cover (11).
- (4) Disconnect four taillight wires (13).
- (5) Remove clearance light wire (12) taillight wires (12) and grommet (14) from fender (15).

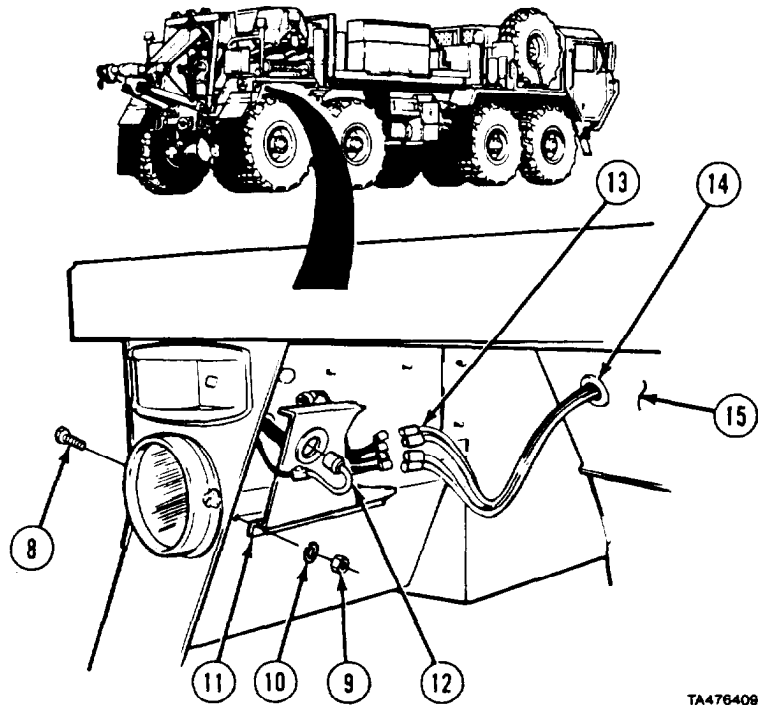

TA476408

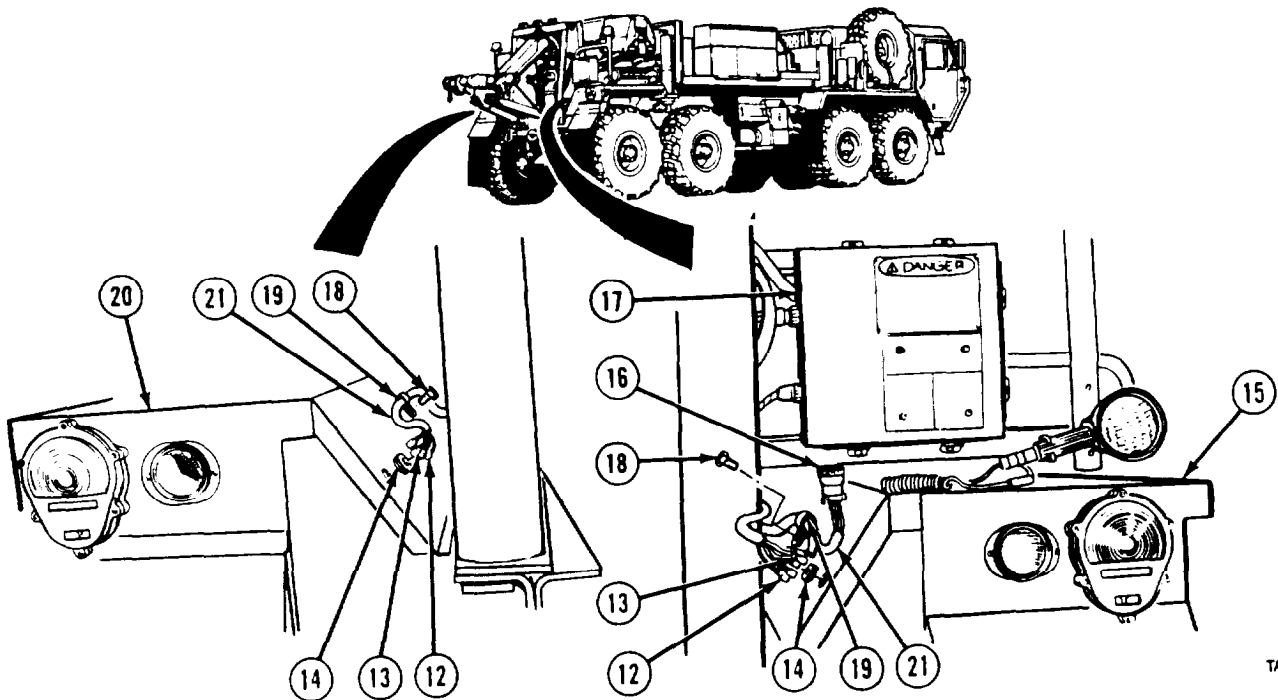

TA476410

- (6) Remove grommets (14) from wires (12 and 13).
- (7) Disconnect connector (16) from high idle control box (17).
- (8) Remove screws (18) and clamps (19) from rear fenders (15 and 20) and chassis wiring harness (21).
- (9) Pull chassis wiring harness (21) under vehicle.

Electrical System Maintenance Instructions (Cont)

6-15.1. CHASSIS WIRING HARNESS REMOVAL/INSTALLATION (M984E1) (CONT).

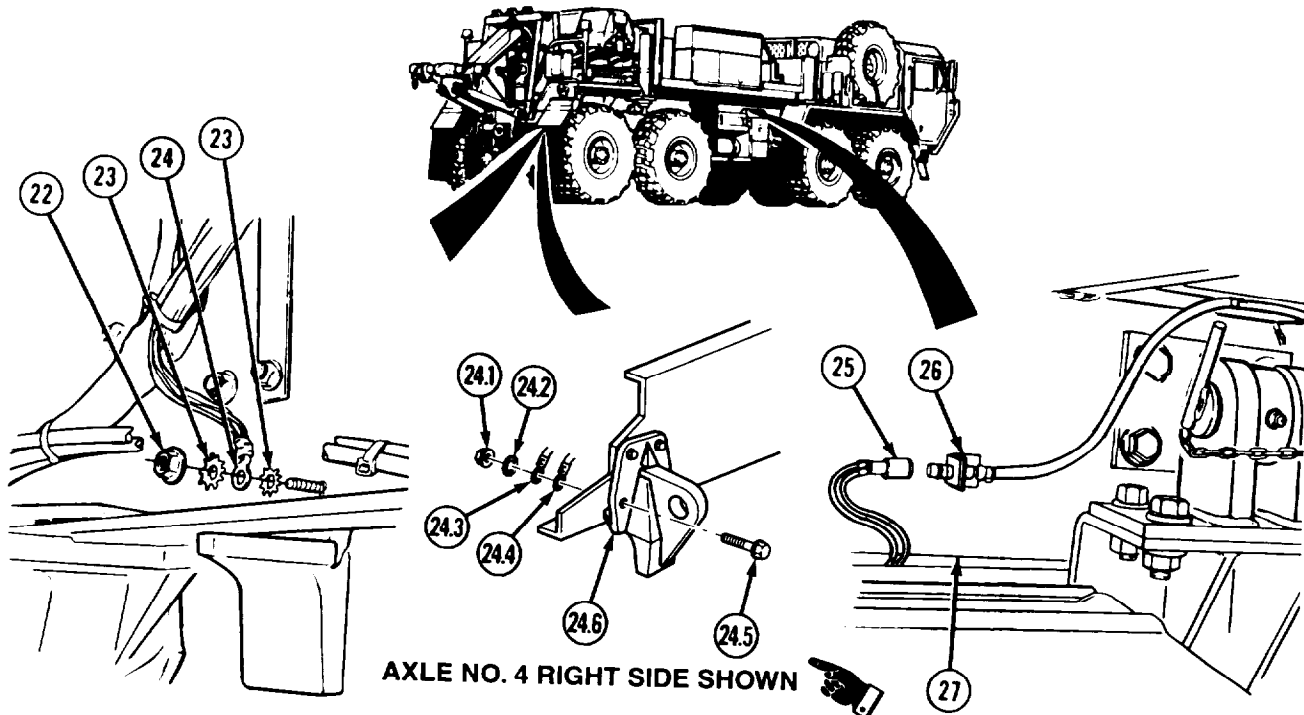

- (10) Remove nut (22), two lockwashers (23), and three wires (24).
- (10.1) Remove nut (24.1), lockwasher (24.2), wires (24.3 and 24.4), and screw (24.5) from right side axle stop (24.6).
- (11) Disconnect connector (25) from clearance light harness connector (26) and equipment body (27).

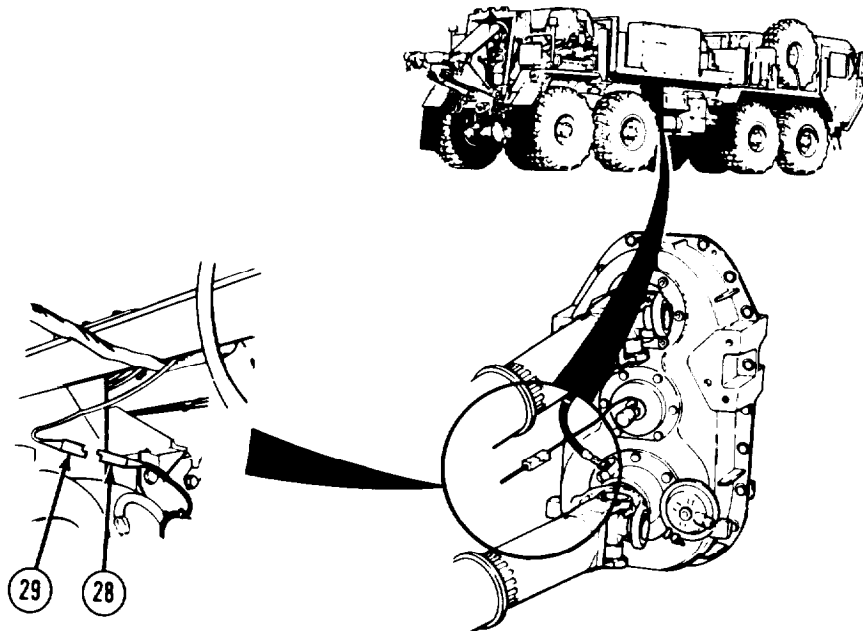

- (12) Remove tape from speedometer wire connector (28) and disconnect connector (29).

Electrical System Maintenance (Cont)

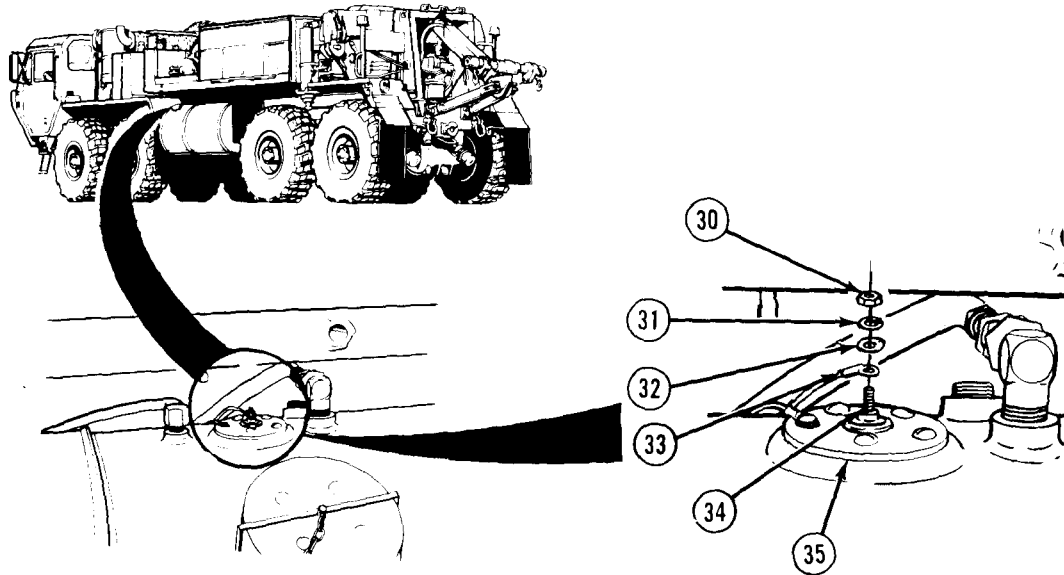

TA476413

- (13) Remove nut (30), lockwasher (31), washer (32), and connector (33) from stud (34) of fuel level sending unit (35).

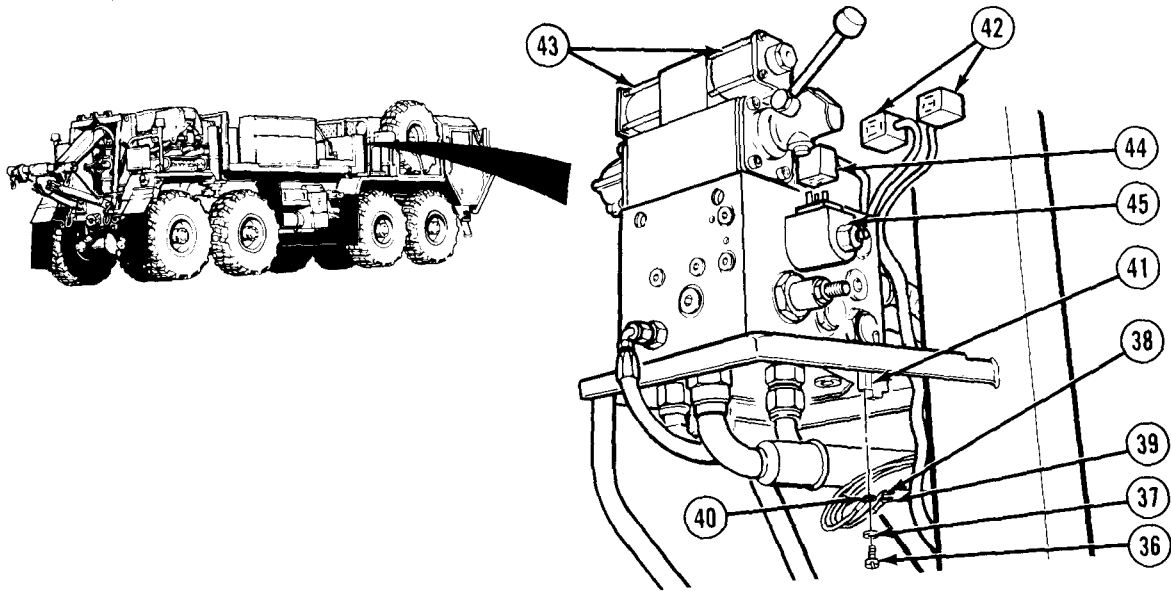

TA476414

- (14) Remove two screws (36), lockwashers (37), and three wires (38, 39, and 40) from switch (41).
 (15) Loosen screw on back of two connectors (42) and disconnect from solenoids (43).
 (16) Loosen screw on top of connector (44) and disconnect from solenoid (45).

Electrical System Maintenance (Cont)

6-15.1. CHASSIS WIRING HARNESS REMOVAL/INSTALLATION (M984E1) (CONT).

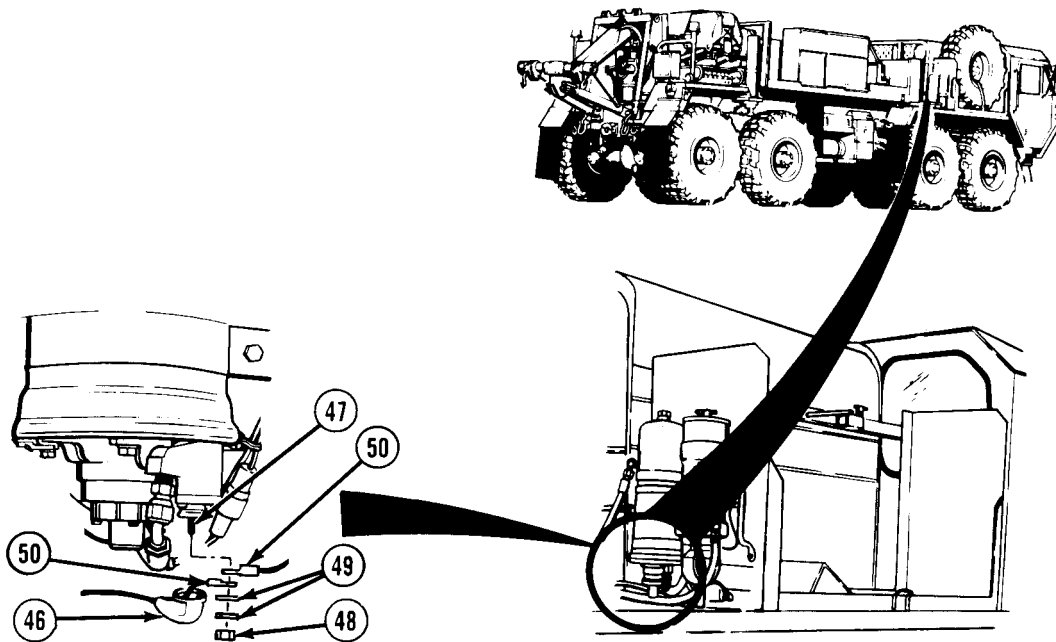

TA476415

(17) Pull back rubber boot (46) from air dryer stud (47).

(18) Remove nut (48), two lockwashers (49), and two wires (50). Remove wires from rubber boot (46).

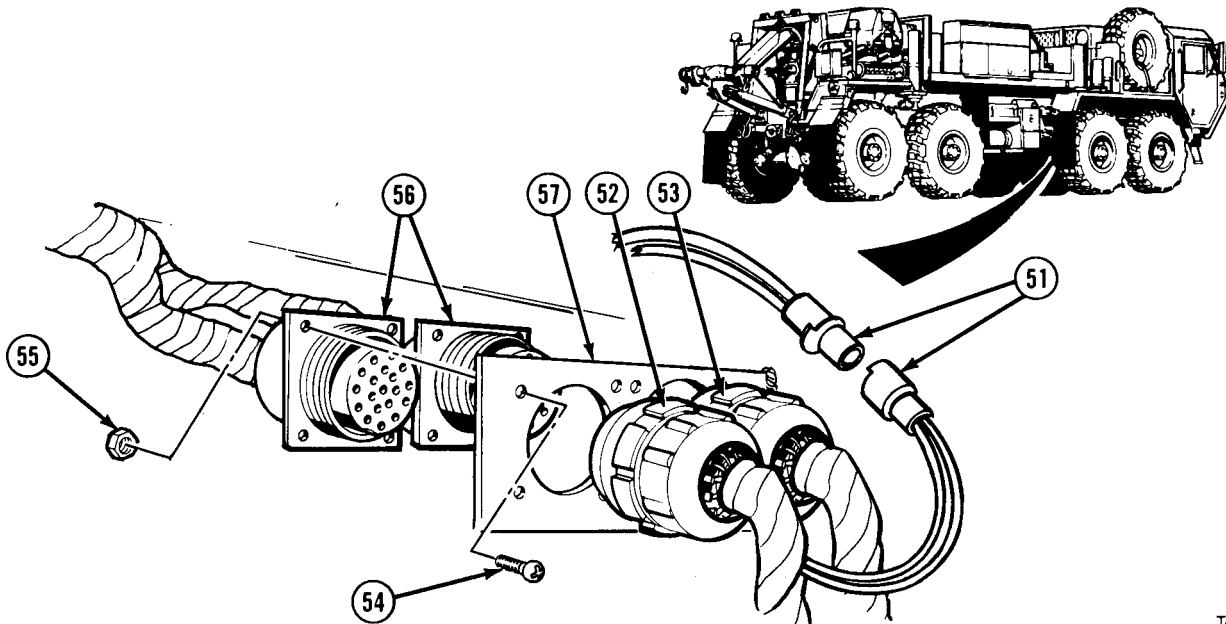

TA476416

(19) Disconnect high idle solenoid connectors (51).

(20) Disconnect two engine wiring harness connectors (52 and 53).

(21) Remove eight screws (54) and locknuts (55) from two chassis wiring harness connectors (56) and remove from bracket (57).

Electrical System Maintenance (Cont)

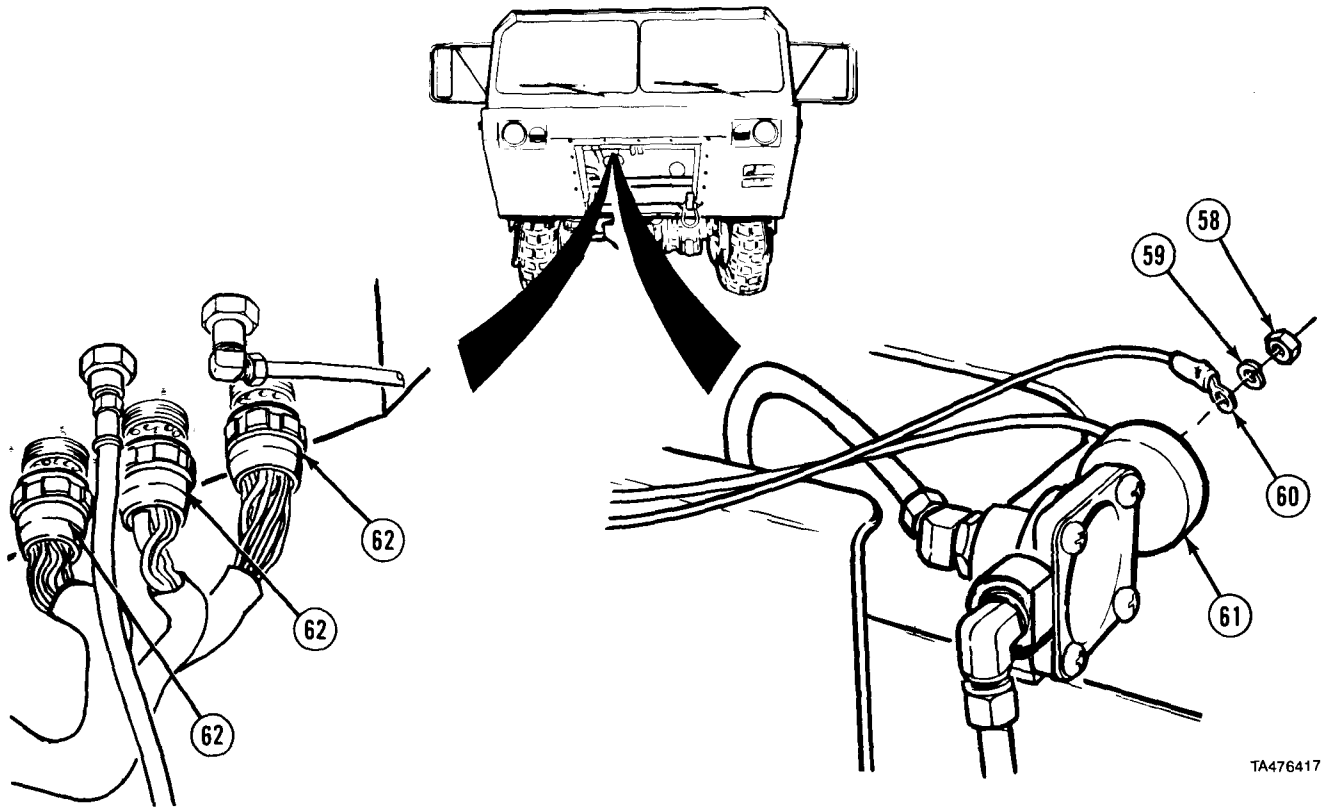

TA476417

- (22) Remove two nuts (58), lockwashers (59), and wires (60) from towing stoplight switch (61).
- (23) Disconnect three connectors (62).

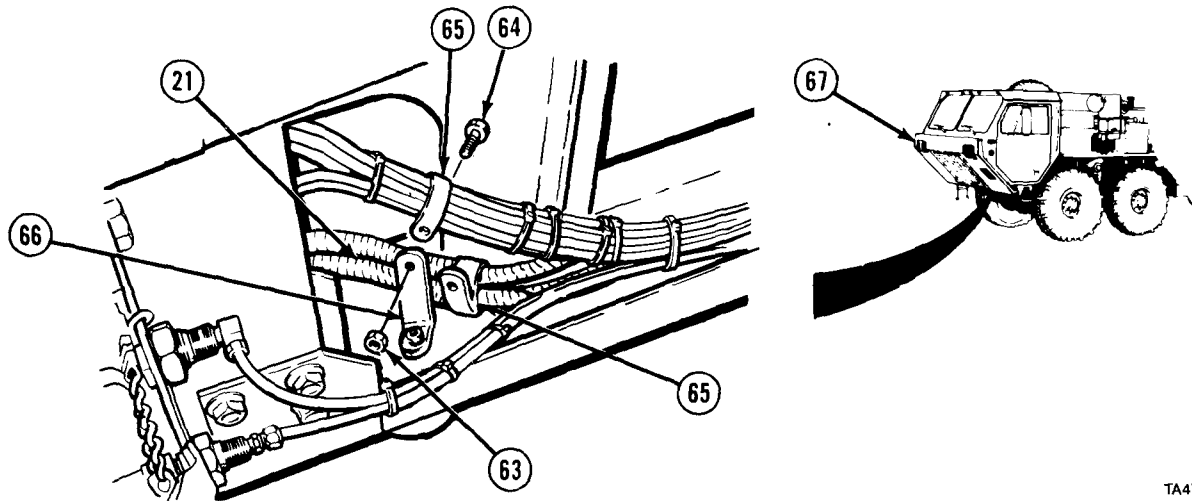

TA476418

- (24) Remove locknut (63), screw (64), and two cushioned clips (65) from bracket (66).
- (25) Remove chassis wiring harness (21) from vehicle (67).

6-15.1. CHASSIS WIRING HARNESS REMOVAL/INSTALLATION (M984E1) (CONT).

b. Installation.

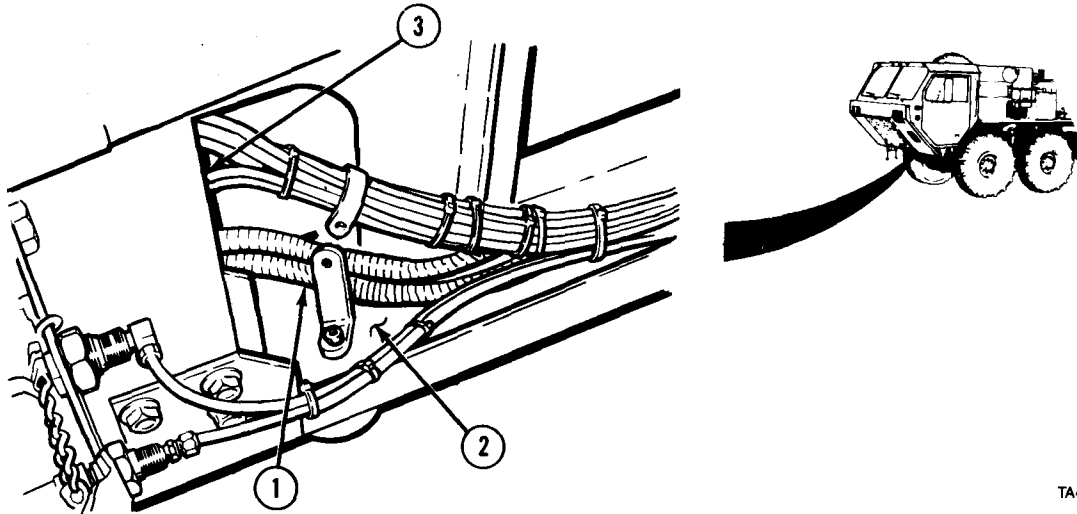

TA476419

NOTE

Install cushioned clips where marked during removal and wire ties as necessary.

(1) Position chassis wiring harness (1) up under right side of cab (2) and over front crossmember (3).

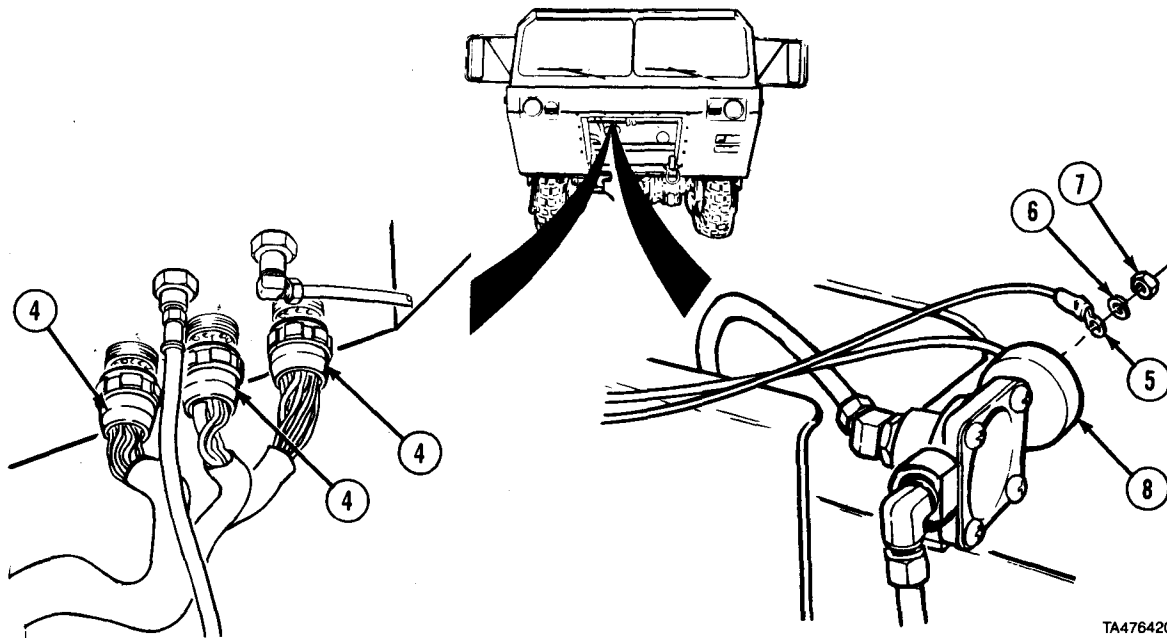

TA476420

(2) Connect three connectors (4).

(3) Install two wires (5), lockwashers (6), and nuts (7) on towing stoplight pressure switch (8).

Electrical System Maintenance (Cont)

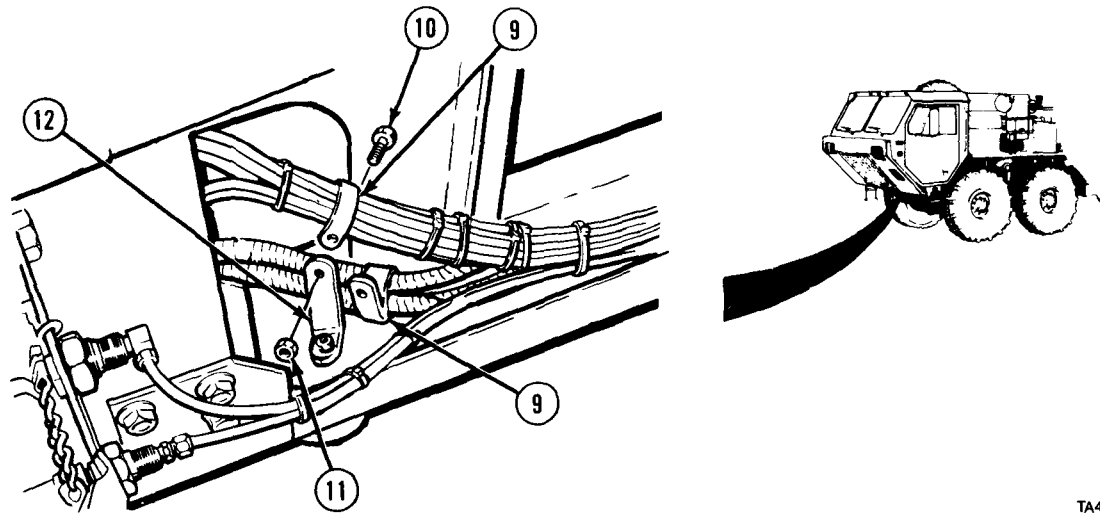

TA476421

(4) Install two cushioned clips (9), screw (10), and locknut (11) to bracket (12).

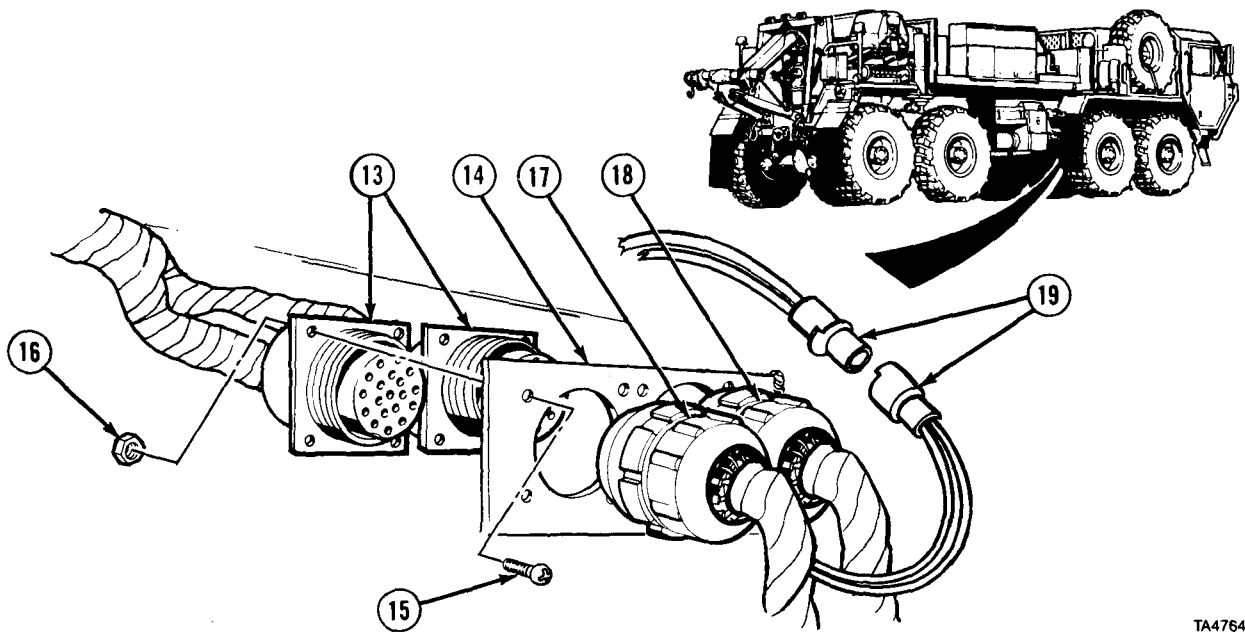

TA476422

- (5) Install two chassis wiring harness connectors (13) in harness bracket (14) with eight screws (15) and locknuts (16).
- (6) Connect two engine wiring harness connectors (17 and 18).
- (7) Connect high idle solenoid connectors (19).

Electrical System Maintenance (Cont)

6-15.1. CHASSIS WIRING HARNESS REMOVAL/INSTALLATION (M984E1) (CONT).

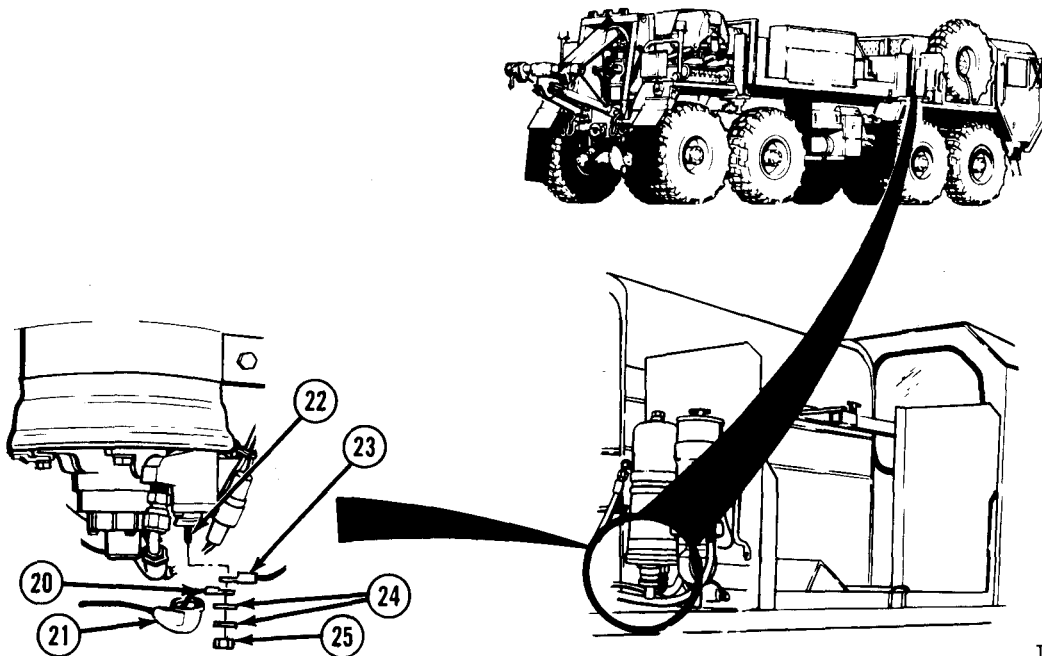

TA476423

- (8) Insert two wires (20) through rubber boot (21) and install to air dryer stud (22) with fuel-water separator wire (23), two lockwashers (24), and nut (25). Push rubber boot over nut (25).

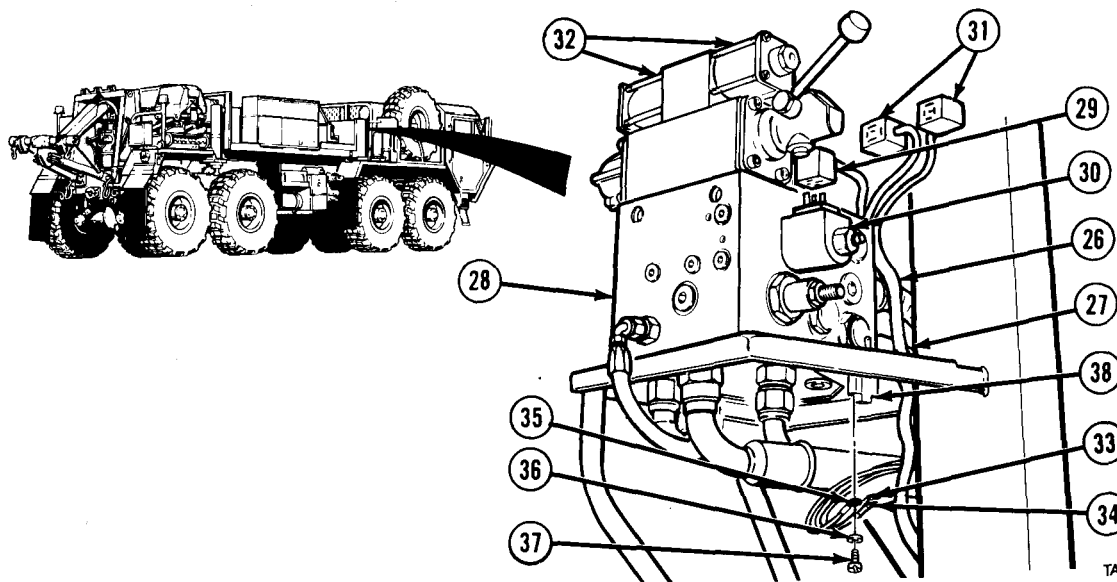

TA476424

- (9) Route chassis wiring harness branch (26) up behind tire davit (27) to heavy duty winch manual control valve (28).
 (10) Connect connector (29) to solenoid (30). Tighten screw on top of connector.
 (11) Connector two connectors (31) to solenoids (32). Tighten screws on back of connectors.
 (12) Install three wires (33, 34, and 35), two lockwashers (36), and screws (37) on switch (38).

Electrical System Maintenance (Cont)

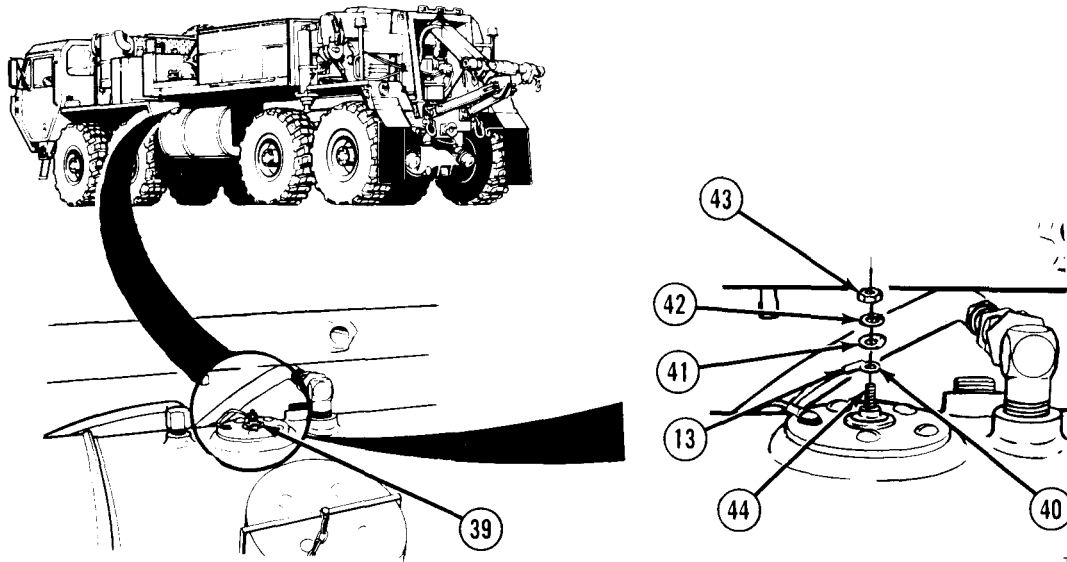

TA476425

- (13) Route wire (13) up to fuel level sending unit stud (39).
- (14) Install connector (40), washer (41), lockwasher (42), and nut (43) on fuel level sending unit stud (44).

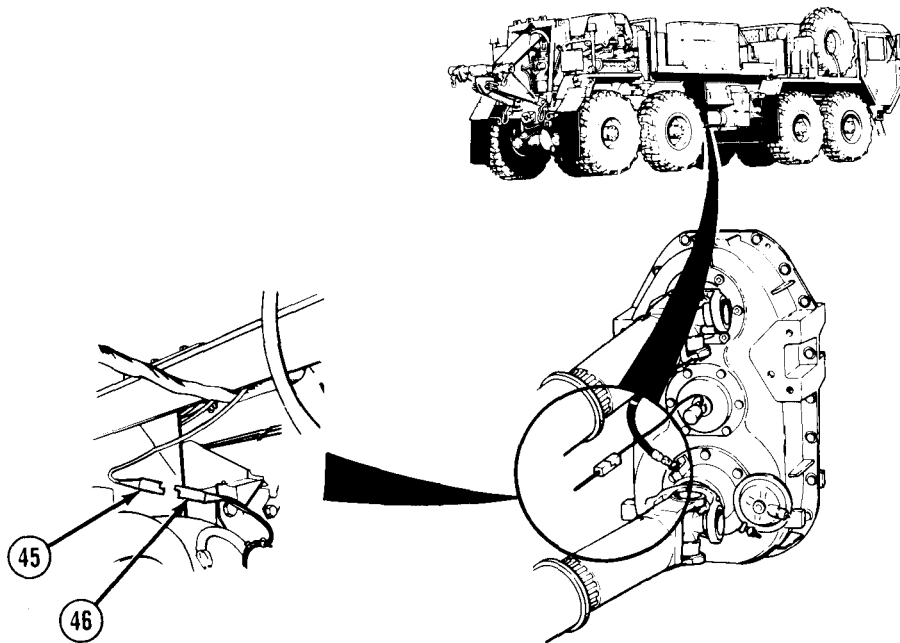

TA476426

- (15) Connect connector (45) to speedometer wire connector (46) and wrap with electrical tape.

Electrical System Maintenance (Cont)

6-15.1. CHASSIS WIRING HARNESS REMOVAL/INSTALLATION (M984E1) (CONT).

- (16) Route clearance light connector (47) to bracket (48) on equipment body (49).
- (17) Connect clearance light connector (47) to clearance light harness connector (50).

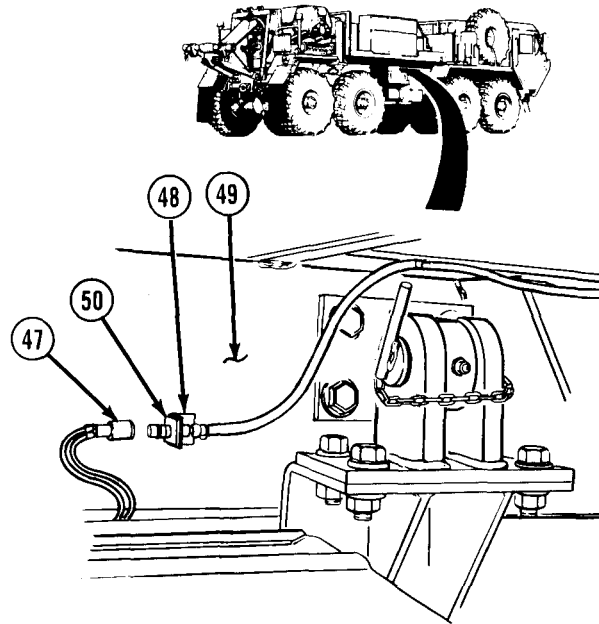

TA476427

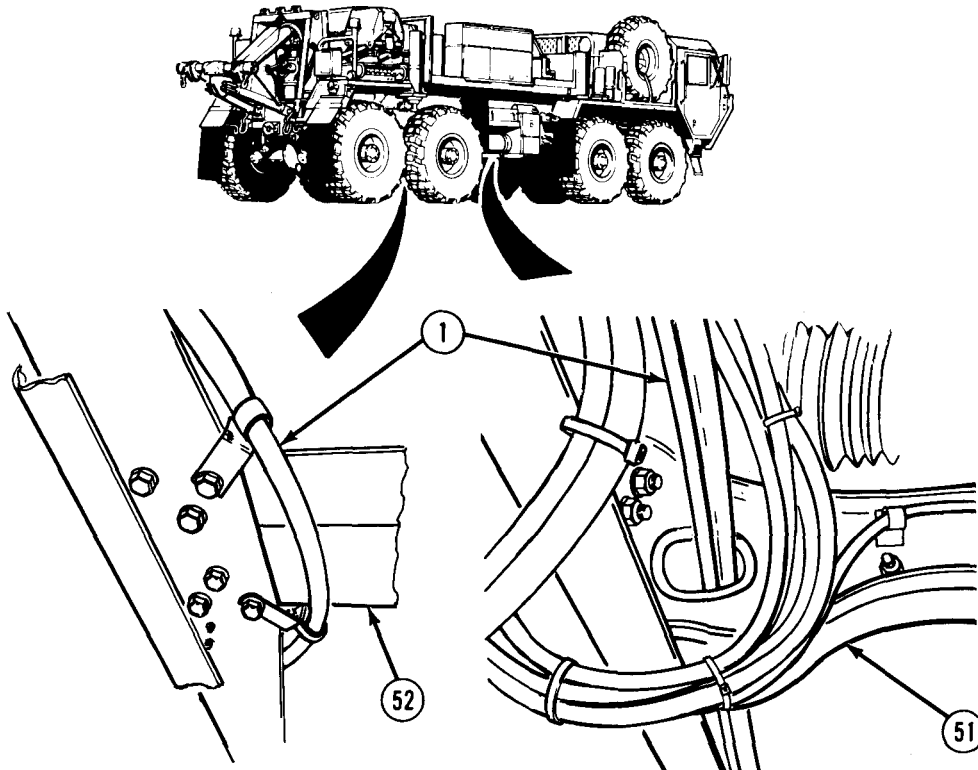

TA476428

- (18) Install chassis wiring harness (1) through rear intermediate crossmember (51) and under rear tandem crossmember (52).

Electrical System Maintenance (Cont)

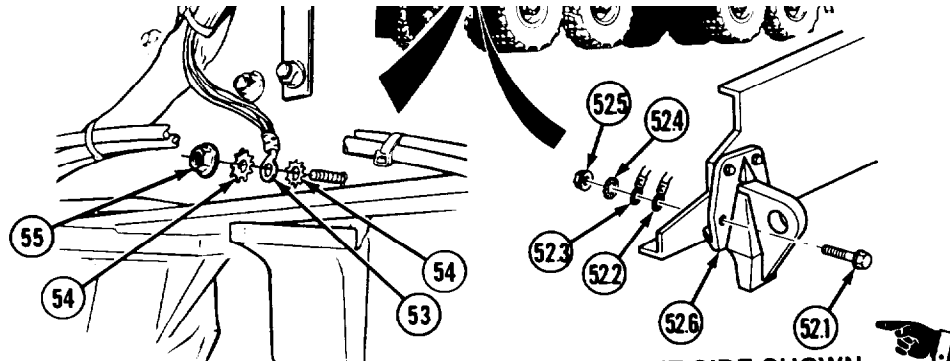

- (18.1) Install Screw (52.1), two wires (52.2 and 52.3), lockwasher (52.4), and nut (52.5) on right side axle stop (52.6).
- (19) Install three wires (53), two lockwashers (54), and nut (55).

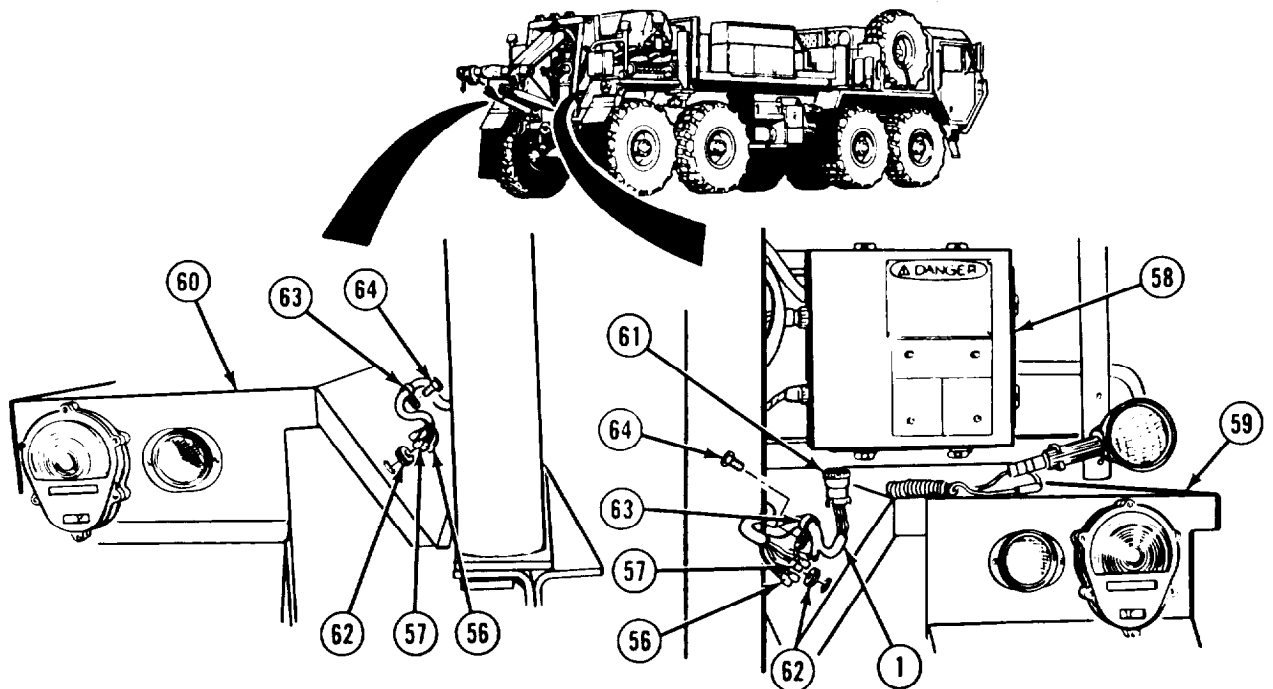

- (20) Route chassis harness (1) and taillight and clearance light wires (56 and 57) up to high idle control box (58) and rear fenders (59 and 60).
- (21) Connect connector (61) to high idle control box (58).
- (22) Install grommets (62) on taillight and clearance light wires (56 and 57).
- (23) Push taillight and clearance light wires (56 and 57) through holes in rear fenders (59 and 60). Install grommets (62) in holes.
- (24) Install two clamps (63) and screws (64).

Electrical System Maintenance (Cont)

6-15.1 CHASSIS WIRING HARNESS REMOVAL/INSTALLATION (M984E1) (CONT).

NOTE

Do steps (26, 27, and 28) for both right and left rear clearance light and taillight wires. Right side shown.

- (25) Install clearance light connectors (65) through grommet (66). Connect connector (65) to wire (56).
- (26) Connect four taillight wires (57).
- (27) Install cover (67) screws (68), lockwashers (69) and nuts (70).

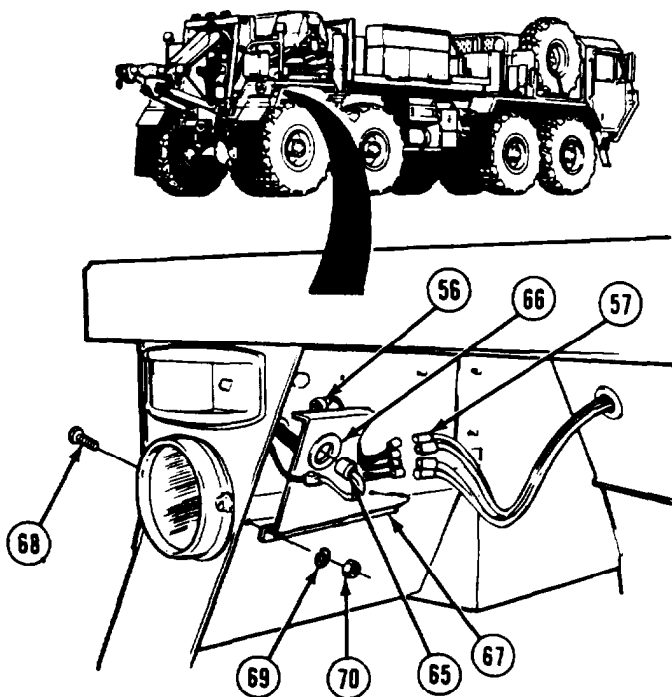

TA478431

- (28) Install trailer electrical connector (71) trailer electrical connector cover (72) four screws (73) three lockwashers (74), two wires (75), two lockwashers (76) and four nuts (77).

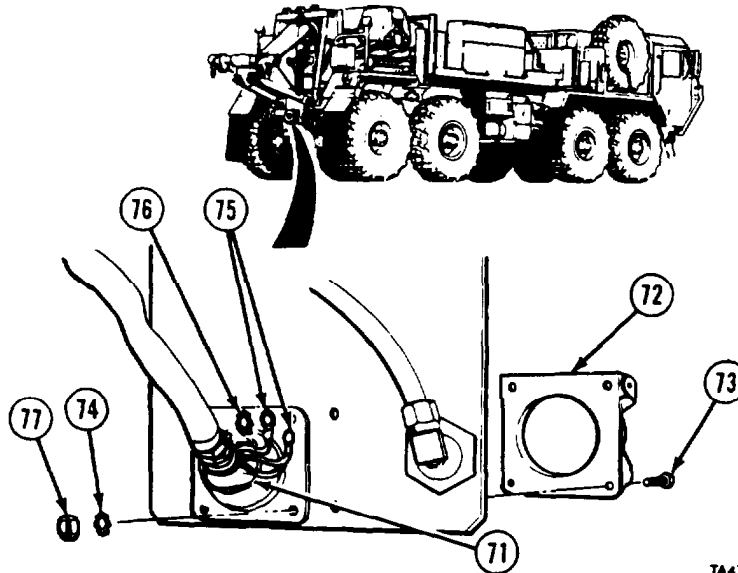

TA478432

c. Follow-on Maintenance.

- (1) Install skid plate grille (TM 9-2320-279-20).
- (2) Connect batteries (TM 9-2320-279-20).

END OF TASK

Electrical System Maintenance (Cont)

6-16. CHASSIS/ENGINE WIRING HARNESS REMOVAL/INSTALLATION.

This task covers:

- a. Removal
b. Installation
c. Follow-on Maintenance

INITIAL SETUP*Models*

All except M984E1

Test Equipment

None

Special Tools

None

Supplies

Tags, identification, Item 60, Appendix C
Ties, cable, plastic, Item 65, Appendix C

Personnel Required

MOS 63W, Wheel vehicle repairer

References

None

Equipment Condition

TM or Para	Condition Description
TM 9-2320-279-20	Batteries disconnected.
TM 9-2320-279-20	Skid plate grille removed.

Special Environmental Conditions

None

General Safety Instructions

None

Level of Maintenance

Direct Support

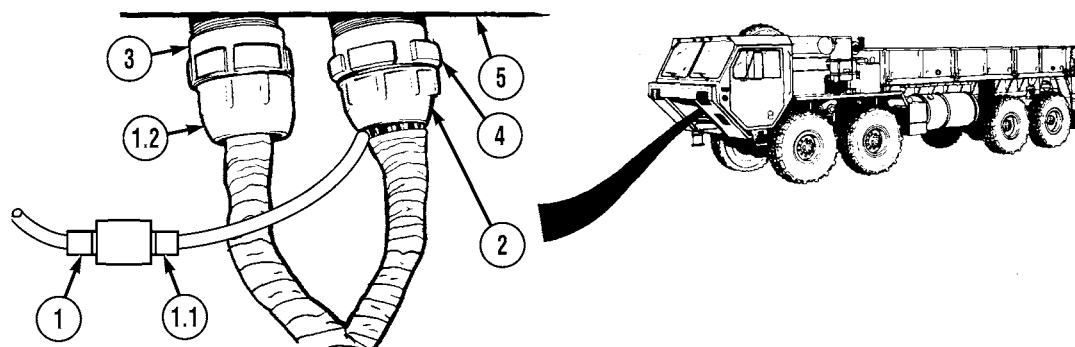
a. Removal.**NOTE**

- Tag and mark all wires and connectors.
- Remove clamps, cushion clips, and plastic ties as necessary.
- Cushion clips are returned to same positions after section of chassis/engine wire harness is removed.
- Do step (1) for M978 only if equipped with high mount stop light.

(1) Disconnect connector (1) from connector (1.1).

(1.1) Remove two plug connectors (1.2 and 2) from receptacles (3 and 4) under cab floor (5).

Electrical System Maintenance Instructions (Cont)

NOTE

Three clips attach chassis/engine harness to frame. All clips are removed from frame the same way.

- (2) Remove nut (6), lockwasher (7), screw (8), washers (9), clip (10), and chassis/engine harness (11) from frame (12).

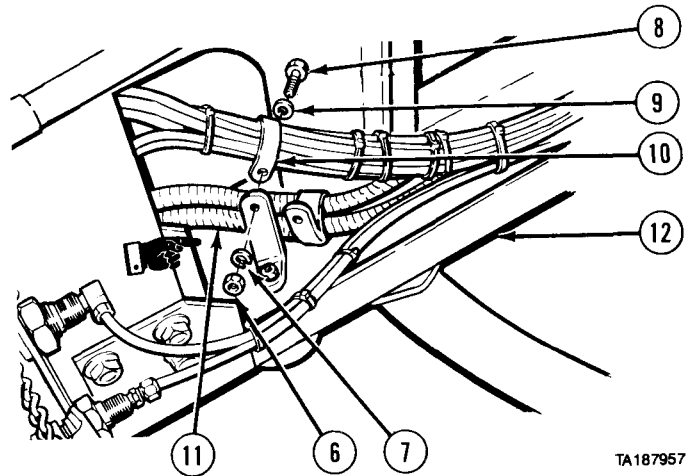

TA187957

NOTE

Tag and mark male engine harness connectors before disconnecting.

- (3) Disconnect two male engine harness connectors (13).
- (4) Remove eight screws (14), lockwashers (15), and nuts (16) from two female chassis/engine harness connectors (17).
- (5) Remove chassis/engine harness (11) from vehicle.

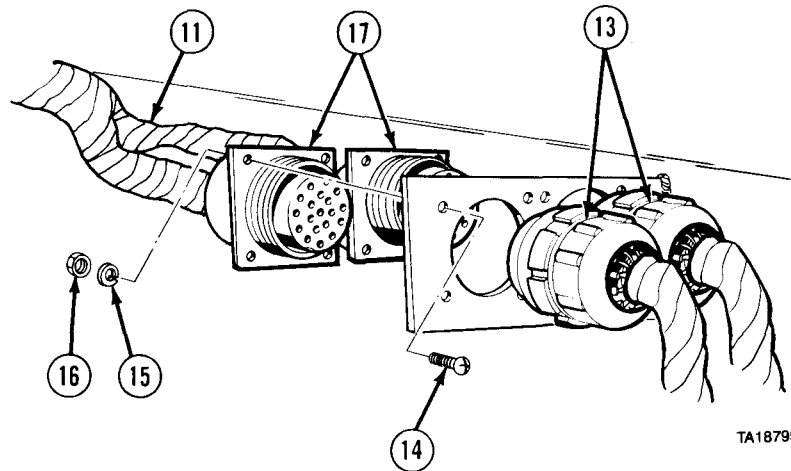

TA187958

b. Installation.

- (1) Install two female chassis/engine harness connectors (1) in harness bracket (2) with eight screws (3), lockwashers (4), and nuts (5).
- (2) Install two male engine harness connectors (6).

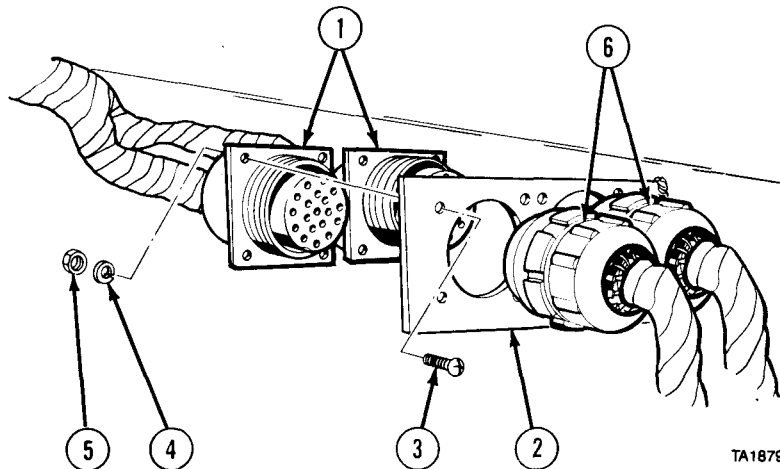

TA187959

Electrical System Maintenance Instructions (Cont)

6-16. CHASSIS/ENGINE WIRING HARNESS REMOVAL/INSTALLATION (CONT).

NOTE

Three clips attach chassis/engine harness to frame. All clips are installed to frame the same way.

- (3) Attach chassis/engine harness (7) to frame (8) with clip (9), screw (10), washer (11), lockwasher (12), and nut (13).

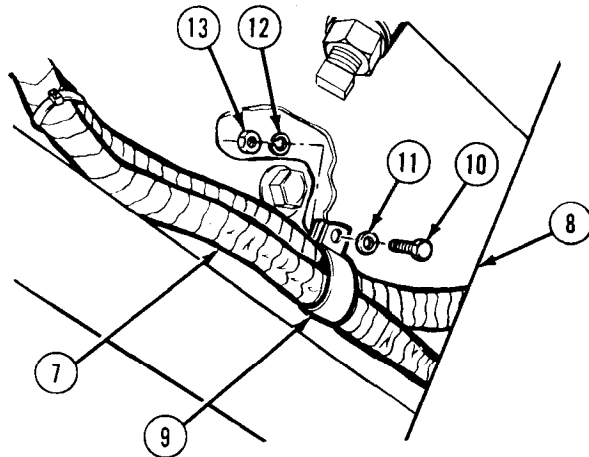

- (4) Route chassis/engine harness (7) through frame (8) and up under cab floor (14). Bundle harness (15) to chassis/engine harness with plastic cable ties along length of harness.

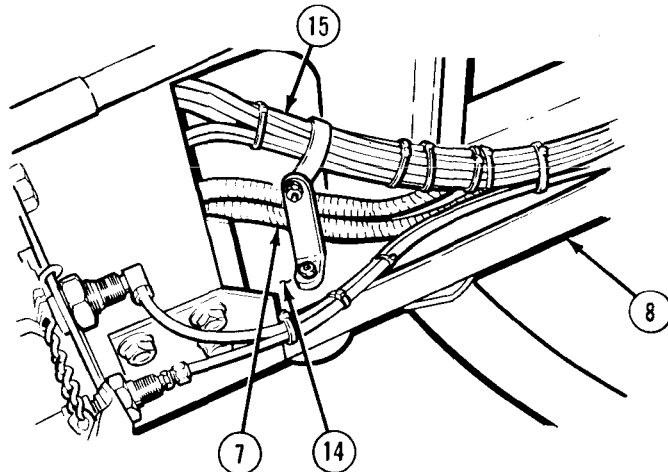

NOTE

Connectors are keyed to fit proper receptacles only.

- (5) Connect two plug connectors (16 and 17) to two receptacles (18 and 19) under cab floor (14).

NOTE

- Install clamps, cushion clips, and plastic ties as necessary.
- Do step (6) for M978 only if equipped with high mount stop light.

- (6) Connect connector (20) to connector (21).

c. Follow-on Maintenance.

- (1) Install skid plate grille (TM 9-2320-279-20).
- (2) Connect batteries (TM 9-2320-279-20).
- (3) Start engine, check vehicle operation (TM 9-2320-279-10).

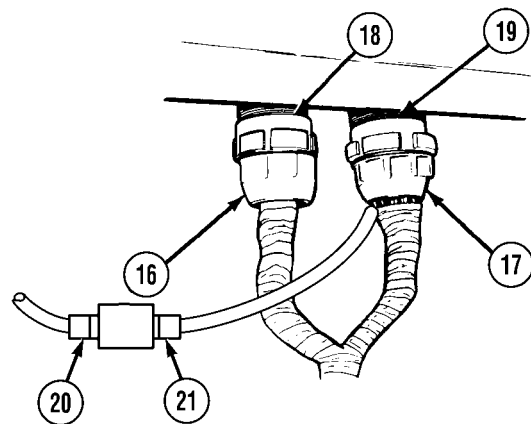

END OF TASK

Electrical System Maintenance Instructions (Cont)

6-17. STE/ICE WIRING HARNESS REMOVAL/INSTALLATION.

This task covers:

- a. Removal
- b. Installation
- c. Follow-on Maintenance

INITIAL SETUP

Models
All

Test Equipment
None

Special Tools
None

Supplies
Ties, cable, plastic, Item 65, Appendix C
Tags, identification, Item 60, Appendix C

Personnel Required
MOS 63W, Wheel vehicle repairer (2)

References
None

Equipment Condition

<i>TM or Para</i>	<i>Condition Description</i>
TM 9-2320-279-20	Batteries disconnected.
TM 9-2320-279-20	Skid plate grille removed.

Special Environmental Conditions
None

General Safety Instructions
None

Level of Maintenance
Direct Support

a. Removal.

(1) Remove cap (1).

NOTE

- Tag and mark all connectors, wires, and plugs before disconnecting.
 - Screws must be held from inside vehicle.
 - Test connector is located on lower right side of console.
- (2) Soldier A removes four screws (2) while Soldier B removes four locknuts (3) and STE/ICE connector (4).

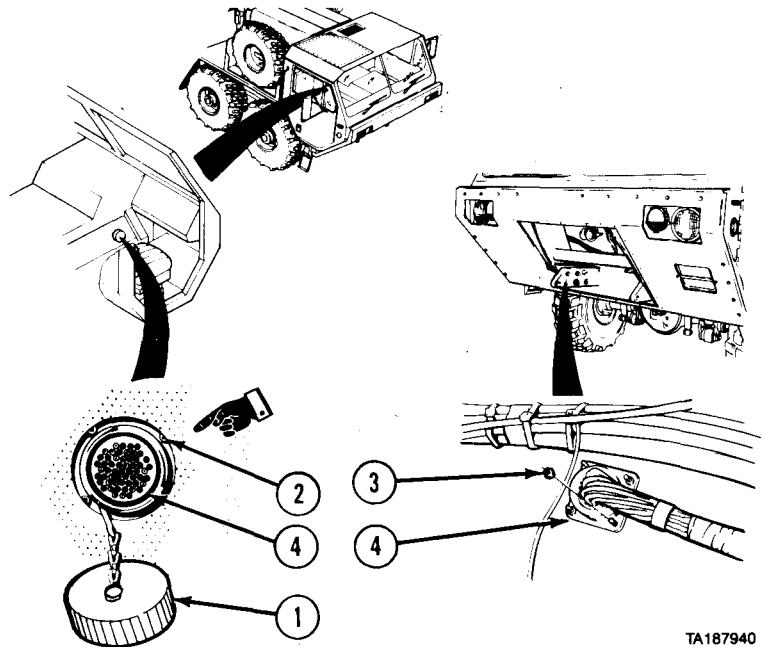

TA187940

Electrical System Maintenance (Cont)

6-17. STE/ICE WIRING HARNESS REMOVAL/INSTALLATION (CONT).

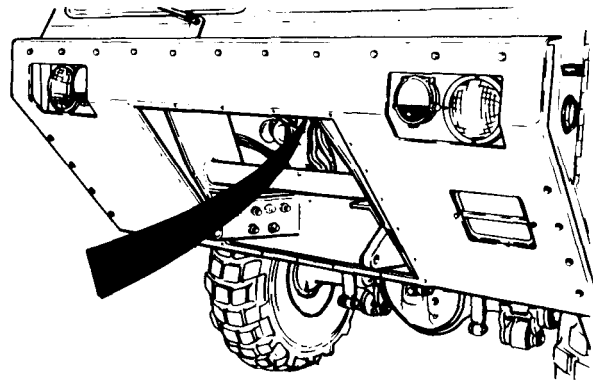
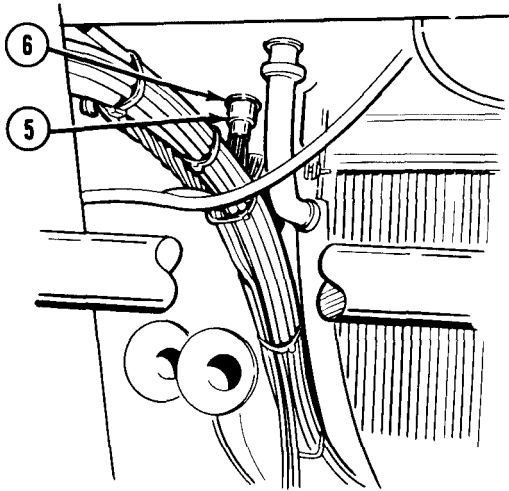

TA187941

(3) Disconnect resistor plug (5) from receptacle (6).

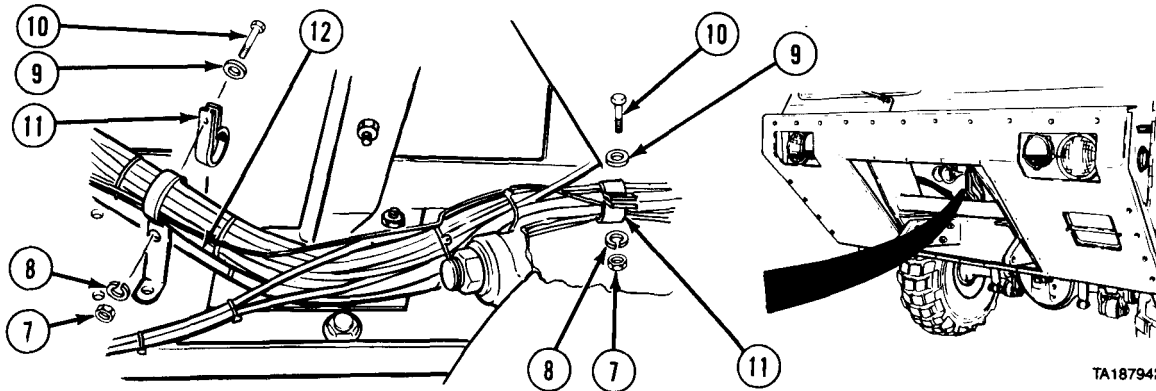

TA187942

NOTE

- Remove all plastic cable ties as required to remove STE/ICE harness.
- M984E1 uses washers in place of lockwashers and locknuts in place of nuts.

(4) Remove five nuts (7), lockwashers (8), washers (9), screws (10), and clamps (11).

(5) Remove STE/ICE harness (12) from five clamps (11).

Electrical System Maintenance Instructions (Cont)

- (6) Disconnect plug (13) from receptacle (14).

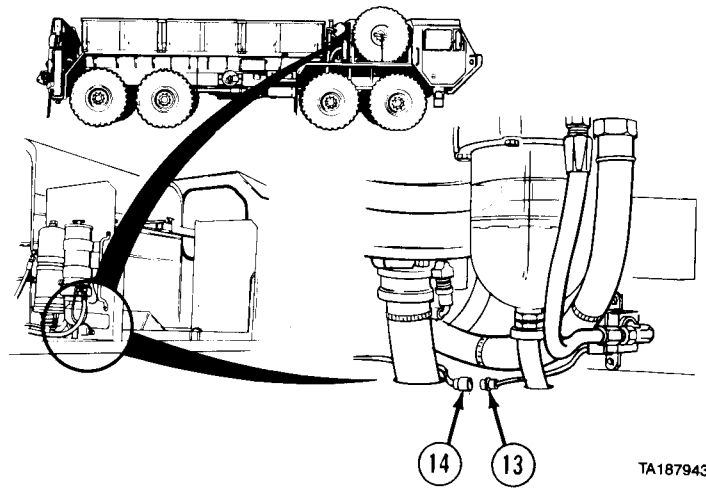

TA187943

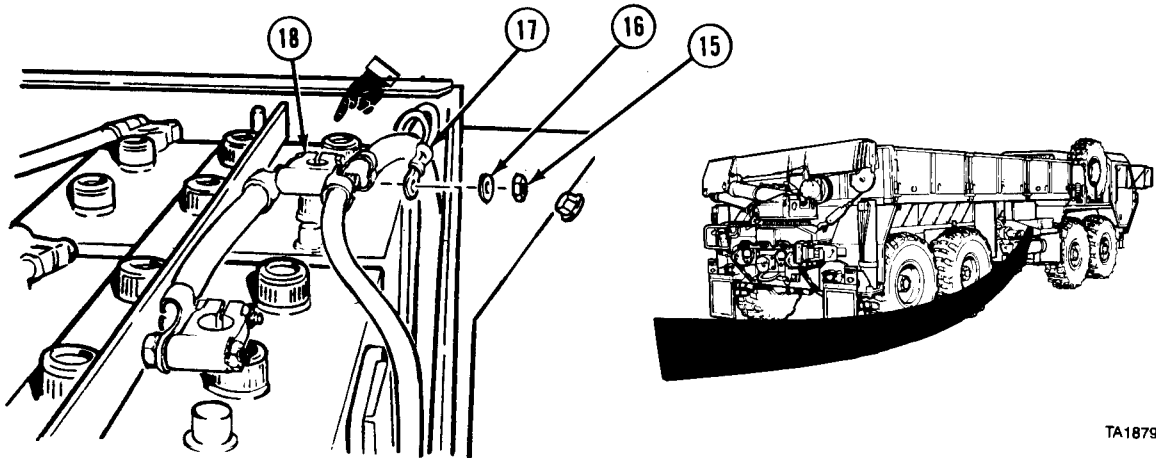

TA187952

- (7) Remove nut (15), washer (16), and STE/ICE wire (17) from negative battery cable lug (18).

- (8) Remove nut (19), washer (20), and STE/ICE wire (21) from positive battery cable lug (22).

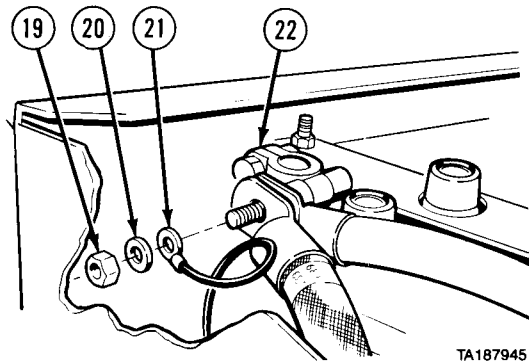

TA187945

Electrical System Maintenance Instructions (Cont)

6-17. STE/ICE WIRING HARNESS REMOVAL/INSTALLATION (CONT).

- (9) Disconnect plug (23) from receptacle (24) just above right rear engine mount (25).
- (10) Remove STE/ICE wiring harness (12).

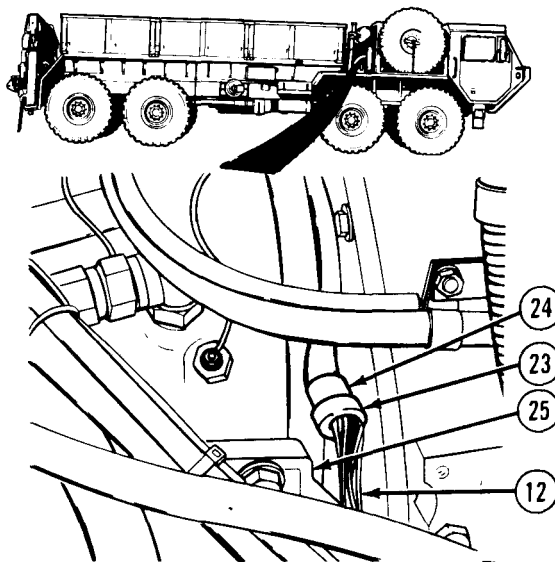

TA187946

b. Installation.

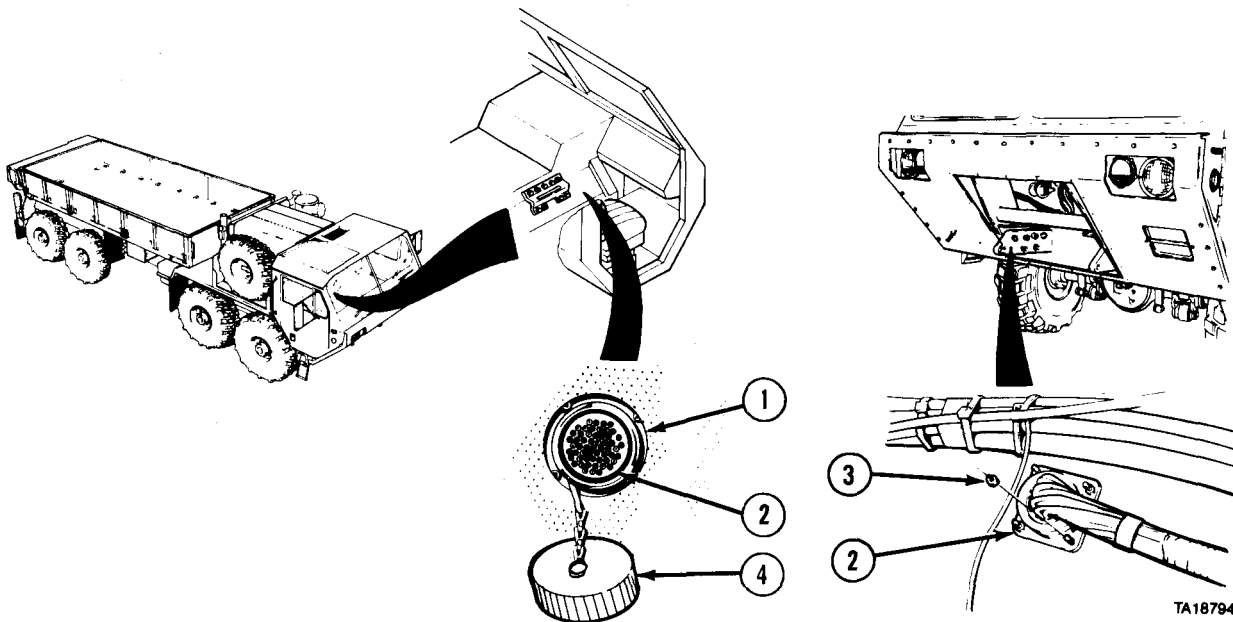

TA187948

- (1) Soldier A installs four screws (1) while Soldier B installs STE/ICE connector (2) and locknuts (3).
- (2) Install cap (4).

Electrical System Maintenance (Cont)

- (3) Connect resistor plug (5) to receptacle (6).

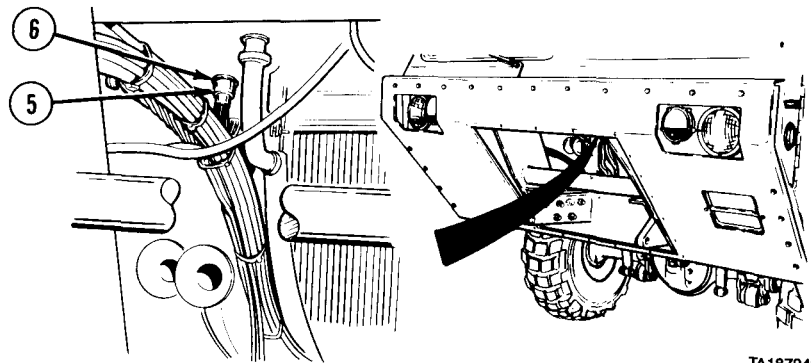

TA187949

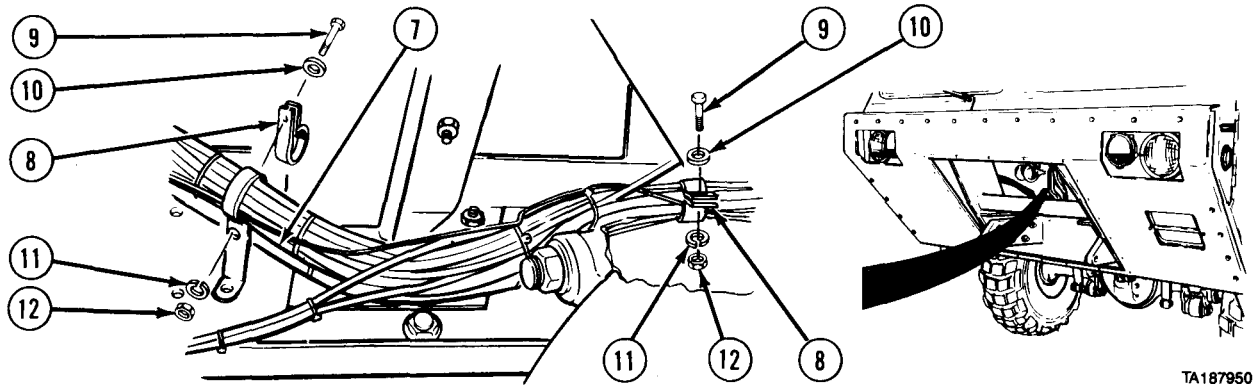

TA187950

NOTE

On M984E1, install washers in place of lockwashers and locknuts in place of nuts.

- (4) Install STE/ICE harness (7) in five clamps (8) with five screws (9), washers (10), lockwashers (11), and nuts (12).
- (5) Connect plug (13) to receptacle (14).

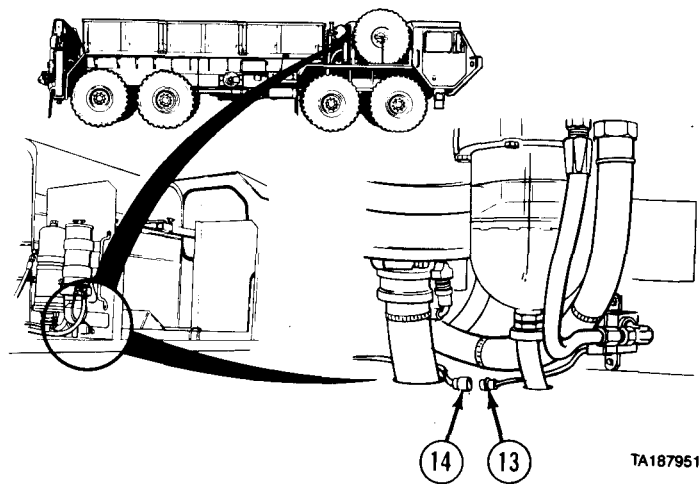

TA187951

Electrical System Maintenance (Cont)

6-17. STE/ICE WIRING HARNESS REMOVAL/INSTALLATION (CONT).

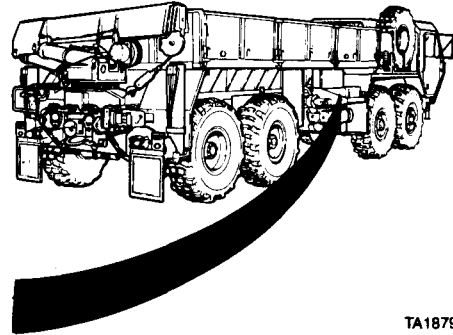
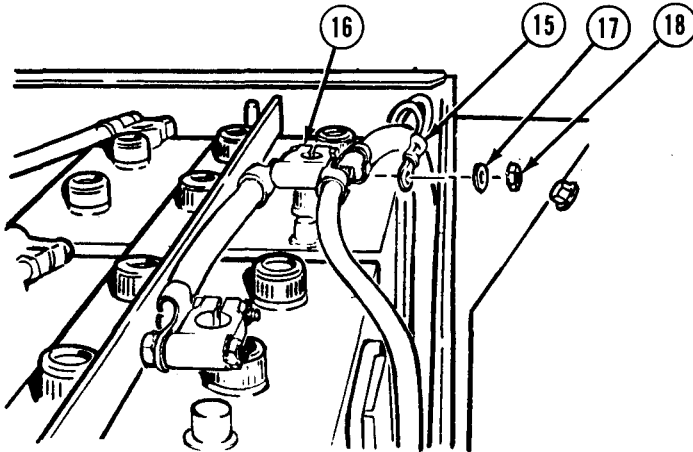

TA187944

(6) Install STE/ICE wire (15) on positive battery cable lug (16) with washer (17) and nut (18).

(7) Install STE/ICE wire (19) on negative battery cable lug (20) with washer (21) and nut (22).

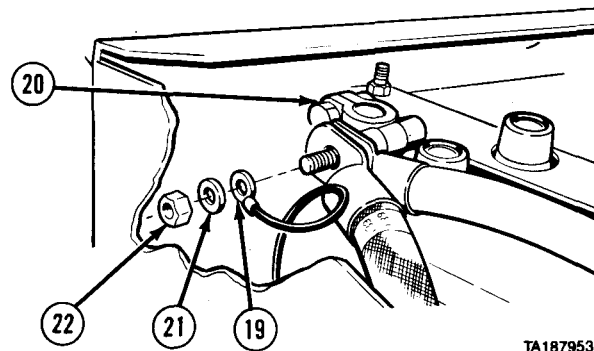

TA187953

NOTE

Install plastic cable ties along STE/ICE harness where removed.

(8) Connect plug (23) to receptacle (24) just above right rear engine mount (25).

c. Follow-on Maintenance.

- (1) Install skid plate grille (TM 9-2320-279-20).
- (2) Connect batteries (TM 9-2320-279-20).
- (3) Check operation of STE/ICE (TM 9-2320-279-20).

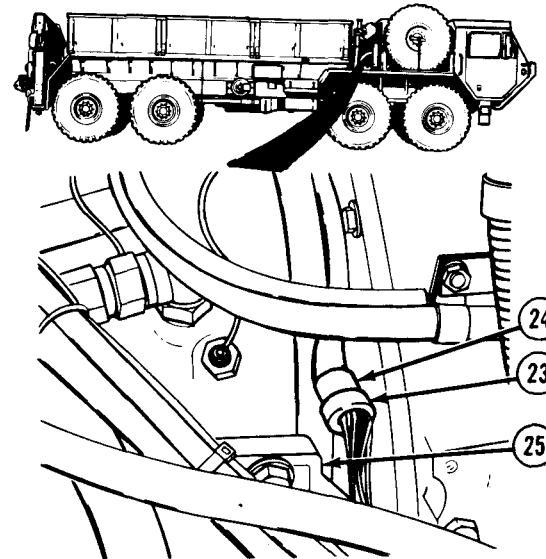

TA187954

END OF TASK

Electrical System Maintenance Instructions (Cont)

6-18. HIGH MOUNT STOP LAMP HARNESS REMOVAL/INSTALLATION (M978).

This task covers:

- a. Removal
- b. Installation
- c. Follow-on Maintenance

INITIAL SETUP

Models

M978

References

None

Test Equipment

None

Equipment Condition

TM or Para

Para 7-91

Condition Description

Batteries disconnected.

Special Tools

None

TM 9-2320-279-10

Pump module rear doors opened.

Supplies

Tags, identification, Item 48, Appendix C

Special Environmental Conditions

None

Personnel Required

MOS 63S, Heavy wheel vehicle mechanic

General Safety Instructions

None

a. Removal.

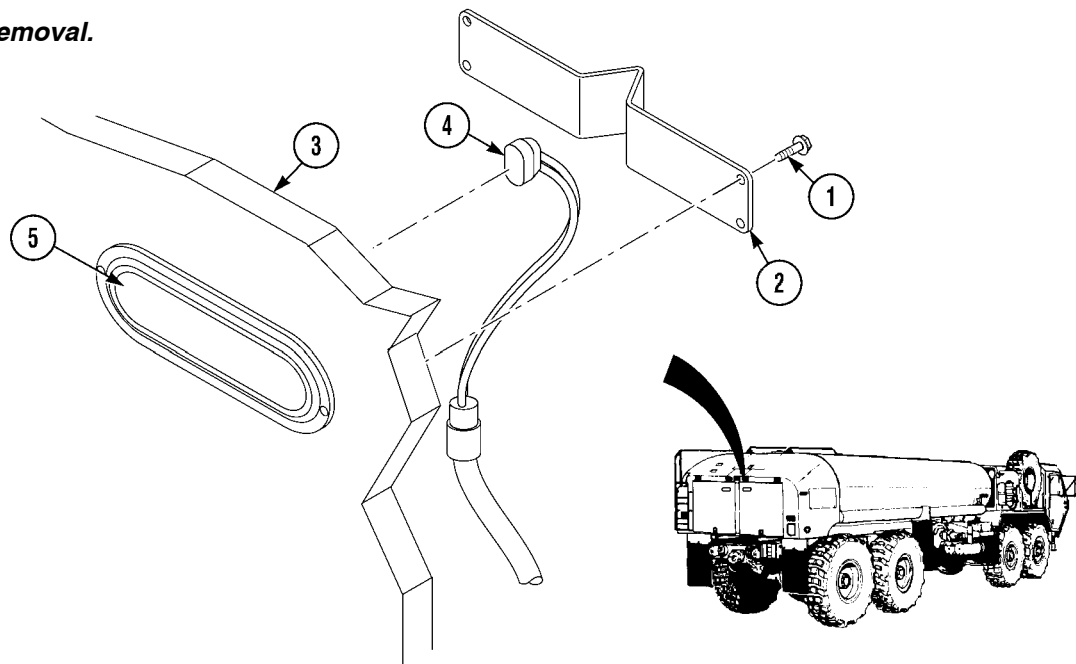

NOTE

Tag and mark wires before disconnecting.

- (1) Remove four screws (1) and guard (2) from rear of right hand door (3).
- (2) Disconnect connector (4) from high mount stop lamp (5).
- (3) Repeat steps (1) and (2) for left hand door.

Electrical System Maintenance Instructions (Cont)

6-18. HIGH MOUNT STOP LAMP HARNESS REMOVAL/INSTALLATION (M978) (CONT).

- (4) Disconnect high mount stop lamp wire harness connector (6) from chassis wire harness connector (7) under left rear of vehicle.

NOTE

- Remove clamps, cushion clips, and cable ties as necessary.
- Cushion clips are returned to same positions after section of high mount stop lamp harness is removed.
- Note routing of high mount stop lamp harness to ensure proper installation.

- (5) Remove high mount stop lamp harness (8) from vehicle.

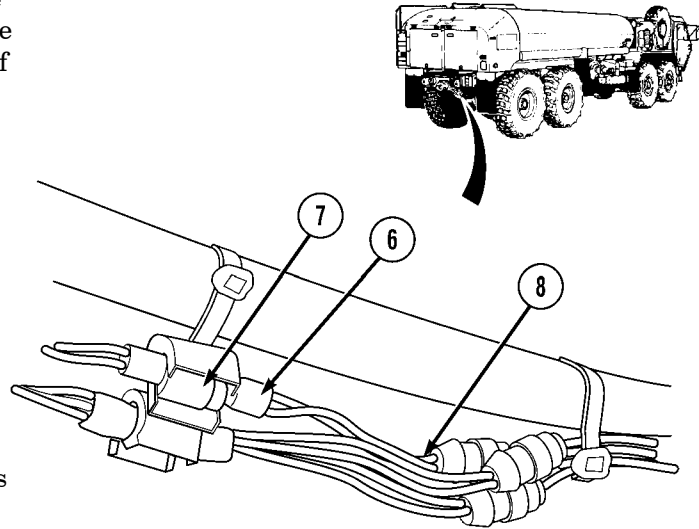

b. Installation.

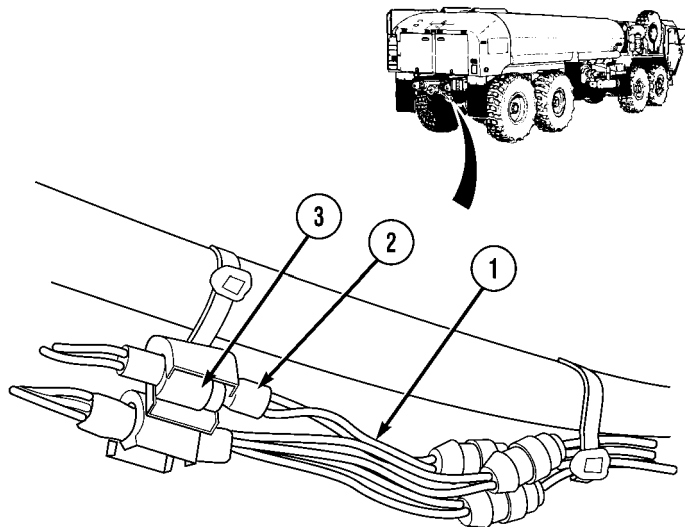

- (1) Position and route high mount stop lamp harness (1) as noted prior to removal.

NOTE

- Install clamps, cushion clips, and cable ties as necessary.
 - Cushion clips are returned to same positions after section of high mount stop lamp harness is installed.
- (2) Connect high mount stop lamp wire harness connector (2) to chassis wire harness connector (3) under left rear of vehicle.

Electrical System Maintenance Instructions (Cont)

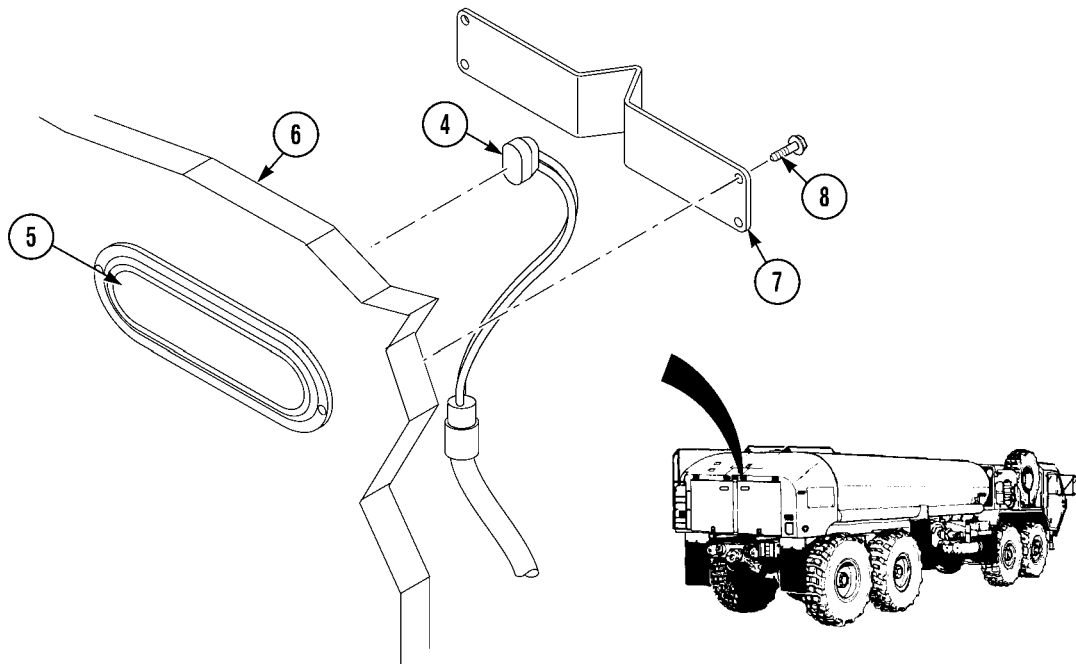

- (3) Connect connector (4) to high mount stop lamp (5) on right hand door (6).
- (4) Install guard (7) on door (6) with four screws (8).
- (5) Repeat steps (3) and (4) for left hand door.

c. *Follow-on Maintenance.*

- (1) Connect batteries (para 7-91).
- (2) Close pump module rear doors (TM 9-2320-279-10).
- (3) Check operation of high mount stop lamps.

CHAPTER 7 TRANSMISSION MAINTENANCE

Contents	Para	Page
General	7-1	7-1
General Maintenance Instructions	7-2	7-1
Transmission Shift Tower Repair	7-3	7-3
Transmission Removal/Installation	7-4	7-8
Transmission Installation/Removal From Transmission Stand....	7-5	7-33
Flywheel AssemblyRemoval/Repair/Installation	7-6	7-36
Torque Converter Stator Removal/Repair/Installation	7-7	7-47
Torque Converter Pump Removal/Repair/Installation	7-8	7-50
Torque ConverterHousingRemoval/Repair/Installation	7-9	7-55
Transmission Housing Repair	7-10	7-68
Oil Pan Removal/Installation.	7-11	7-72
Internal Filter Element Removal/Installation	7-12	7-76
Gear Unit and Main Shaft Assembly Removal/Repair/Installation	7-13	7-77
Output Yoke, Dust Shield, and Oil Seal Removal/Installation	7-14	7-89
Forward Clutch AssemblyRemoval/Repair/Installation.	7-15	7-91
Rear Cover and First Clutch Assembly Removal/Repair/Installation	7-16	7-106
Fourth Clutch AssemblyRemoval/Repair/Installation	7-17	7-116
Third Clutch and Center Support Housing Removal/Repair/Installation.	7-18	7-122
Second Clutch and Center Support Housing Removal/Repair/Installation	7-19	7-130
Control Valve BodyRemoval/Repair/Installation	7-20	7-135
Modulator Valve Removal/Installation	7-21	7-153
Lock up Cutoff ValveBodyRemoval/Repair/Installation	7-22	7-154
Governor Removal/Installation.	7-23	7-156

Section 1. INTRODUCTION

7-1. GENERAL. This chapter contains maintenance instructions for removal, installation, and repair of the transmission at the direct support and general support maintenance levels. Subassemblies and parts which must be removed before transmission components can be removed or repaired are referenced to other paragraphs of this manual or TM 9-2320-279-20.

Section II. SERVICE AND INSPECTION

Transmission Maintenance Instructions

7-2. GENERAL MAINTENANCE INSTRUCTIONS.

- a. Follow these maintenance practices when working on the transmission.
 - (1) Handle transmission parts and subassemblies carefully to prevent nicking, scratching, and denting. Parts which fit together closely and must have proper operating clearance can bind if damaged. This is very important concerning parts of the control valve body assembly (valves, when dry, must move freely by their own weight). Parts which depend upon smooth surfaces for sealing may leak if scratched.
 - (2) Do not use metal tools on transmission housing when removing gaskets, packings, or seals to avoid scratching sealing surfaces. Use pointed wooden dowel to remove packings from grooves. Use wooden or plastic scrapers on gasket surfaces.

Transmission Maintenance Instructions (Cont)

7-2. GENERAL MAINTENANCE INSTRUCTIONS (CONT).

b. Follow these cleaning instructions when working on the transmission.

- (1) All parts must be clean to permit effective inspection. During assembly no dirt or foreign material can be allowed to enter the transmission. Even minute particles can cause malfunction of close-fit parts, such as valves.

WARNING

Adhesives, solvents, and sealing compounds can burn easily, can give off harmful vapors, and are harmful to skin and clothing. To avoid injury or death, keep away from open fire and use in well-ventilated area. If adhesive, solvent, or sealing compound gets on skin or clothing, wash immediately with soap and water.

- (2) All transmission metallic parts, except bearings and friction-faced clutch plates, should be cleaned thoroughly with dry cleaning solvent or by steam cleaning method. Do not use caustic soda solution for steam cleaning. Use only dry cleaning solvent to clean friction-faced clutch plates.

WARNING

Compressed air used for cleaning and drying purposes will be reduced to 30 psi (207 kPa) and used only with adequate chip guarding and personal protection equipment, goggles, shield, and gloves.

- (3) Bearings should drip and air dry, then be oiled. Other parts should be dried with compressed air. Steam cleaned parts should be oiled immediately after drying to prevent rust.
- (4) Clean oil passages by working a piece of soft wire back and forth through the passages and flushing with dry cleaning solvent. Dry passages with compressed air.
- (5) Examine parts, especially oil passages, after cleaning to make certain they are entirely clean. Reclean parts if necessary.

c. Follow these inspection instructions when working on the transmission.

- (1) Inspect surfaces in contact with gaskets, packings, or seals for nicks, burrs, or scratches. Remove any defect before assembly.
- (2) Before inspection, oil bearings lightly with same type of oil used in transmission to prevent damage to bearings.
- (3) Inspect bores for wear, scratches, grooves, burrs, and dirt. Remove scratches, grooves, and burrs with crocus cloth. Remove foreign matter. Replace deeply scratched or grooved parts.
- (4) Inspect housings and other cast parts for cracks.
- (5) Inspect machined surfaces for damage that could cause oil leakage or other malfunction. Correct damage with crocus cloth, if possible, or replace defective parts.
- (6) Inspect gears for scuffed, nicked, burred, worn, or broken teeth. If defect cannot be removed with soft stone, replace gear.
- (7) Inspect thrust face of gears for scoring, scratches, and burrs. Remove defects with soft stone. If scratches and scoring cannot be removed with soft stone, replace gear.
- (8) Inspect splined parts for stripped, twisted, chipped, or burred splines. Remove burrs with soft stone. Replace part if other defects are found. Spline wear is not considered defective except where it affects tightness of an assembly such as driveline flanges.
- (9) Inspect retaining rings for nicks, distortion, and looseness. Retaining ring must snap tight in groove for proper functioning. Replace retaining ring if any defects are found.
- (10) Inspect springs for signs of overheating, permanent set, or wear due to rubbing adjacent parts. Replace spring if any of these defects are found.
- (11) Inspect friction clutch plates (internal-splined plates) for burrs, embedded metal particles, severely pitted faces, loose facings, excessive wear, cracks, distortion, and damaged spline teeth. Remove burrs using soft stone. Replace clutch plates which have other defects.
- (12) Inspect steel clutch plates (external-tanged plates) for burrs, scoring, excessive wear, distortion, embedded metal, galling, cracks, breaks, and damaged tangs. Remove burrs and minor surface defects using soft stone. Replace clutch plates which have other defects.

Transmission Maintenance Instructions (Cont)

- (13) At locations contacted by hook-type and step-joint seal rings, inspect inside diameter for step-wear, nicks, scratches, and scoring. Remove only raised metal portion of defects with soft stone or crocus cloth. Polishing to remove defect is not necessary or desirable. If defects are too severe, replace defective part.
- (14) At locations contacted by spring-loaded, lip-type oil seals, inspect for nicks, scratches, roughness, or other surface irregularities. Inspect for embedded particles, step-wear, and dirt on flanges or any components exposed to external contamination. Remove defects and restore finish with crocus cloth. Replace parts if scoring or scratches permit oil leakage.

Section III. SHIFT TOWER

7-3. TRANSMISSION SHIFT TOWER REPAIR.

This task covers:

- a. Disassembly
- b. Cleaning/Inspection
- c. Assembly
- d. Follow-on Maintenance

INITIAL SETUP

Models

All

Test Equipment

None

Special Tools

None

Supplies

Solvent, dry cleaning, Item 57, Appendix C
Grease, automotive and artillery, Item 34, Appendix C

Personnel Required

MOS 63W, Wheel vehicle repairer

References

None

Equipment Condition

<i>TM or Para</i>	<i>Condition Description</i>
TM 9-2320-279-10	Shut off engine.
TM 9-2320-279-20	Shift cable removed.
TM 9-2320-279-20	Shift control removed.

Special Environmental Conditions

None

General Safety Instructions

None

Level of Maintenance

Direct Support

Transmission Maintenance Instructions (Cont)

7-3. TRANSMISSION SHIFT TOWER REPAIR (CONT).

a. Disassembly.

- (1) Remove cotter pin (1) and washer (2).
- (2) Remove nut (3), washer (4), spacer (5), switch (6), washer (7), and screw (8).

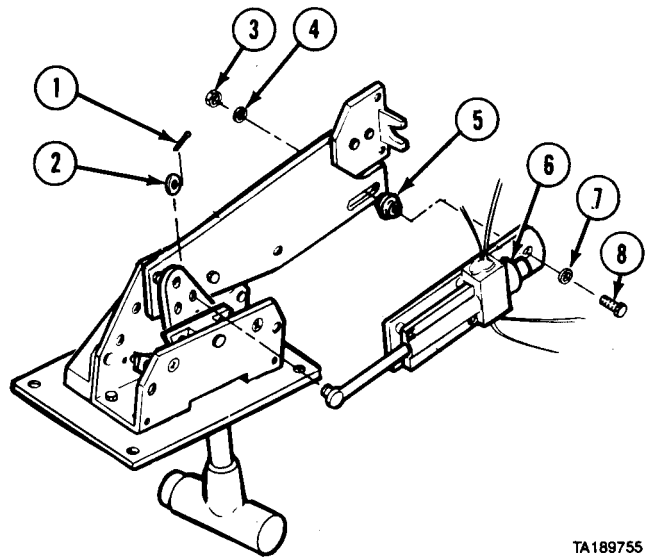

TA189755

- (3) Remove two nuts (9), screws (10), and angle bracket (11).

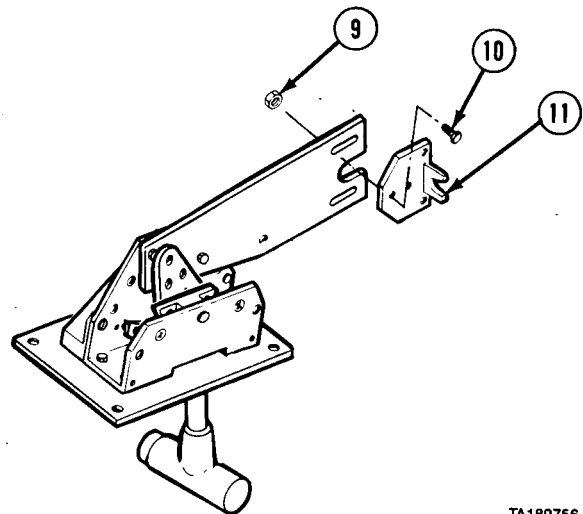

TA189756

Transmission Maintenance Instructions (Cont)

- (4) Remove two screws (12), lockwashers (13), and bracket (14).
- (5) Place lever (15) in third gear position.
- (6) Remove nut (16), screw (17), and lever (15).

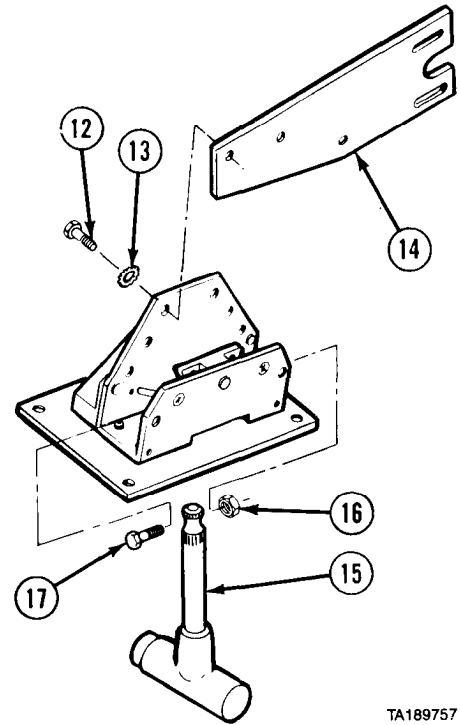

TA189757

- (7) Remove two locknuts (18) and screws (19).
- (8) Remove four locknuts (20), housing assembly (21), and four washers (22) from plate assembly (23).
- (9) Remove lens (24) from plate assembly (23).
- (10) Remove segment (25) from housing assembly (21).

b. Cleaning/Inspection.

WARNING

Adhesives, solvents, and sealing compounds can burn easily, can give off harmful vapors, and are harmful to skin and clothing. To avoid injury or death, keep away from open fire and use in well-ventilated area. If adhesive, solvent, or sealing compound gets on skin or clothing, wash immediately with soap and water.

- (1) Clean all metal parts in dry cleaning solvent.
- (2) Inspect all metal parts for excessive wear and damage.
- (3) Inspect rubber and plastic parts for cracks and excessive wear.
- (4) Inspect wires for cracking and fraying.
- (5) Replace damaged parts.

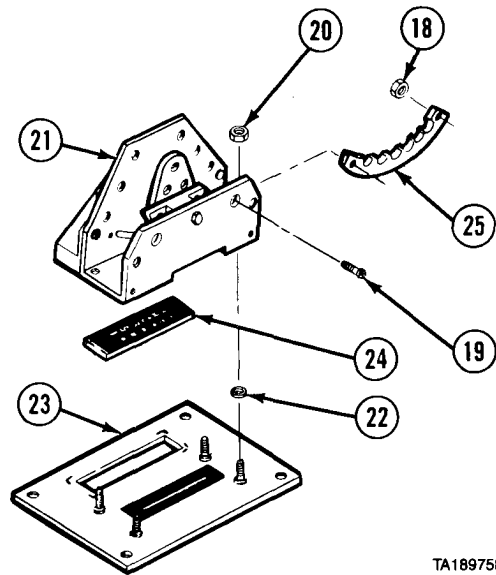

TA189758

Transmission Maintenance Instructions (Cont)

7-3. TRANSMISSION SHIFT TOWER REPAIR (CONT).

c. Assembly.

- (1) Install lens (1) in plate assembly (2).
- (2) Install housing assembly (3) on plate assembly (2) with four washers (4) and locknuts (5).
- (3) Apply grease to teeth of segment (6).
- (4) Install segment (6) with two screws (7) and locknuts (8).

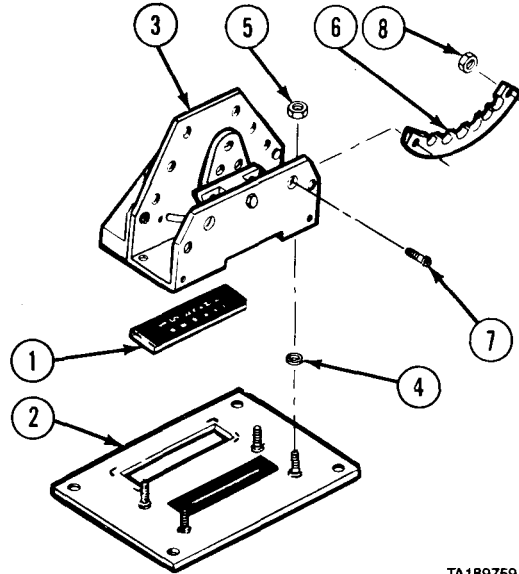

TA189759

NOTE

Check that segment is properly aligned when installing lever. When lever is installed correctly, pressing button on handle will disengage pawl from segment.

- (5) Place lever (9) in third gear position.
- (6) Install lever (9) with screw (10) and nut (11).
- (7) Install bracket (12) with two screws (13) and lockwashers (14).

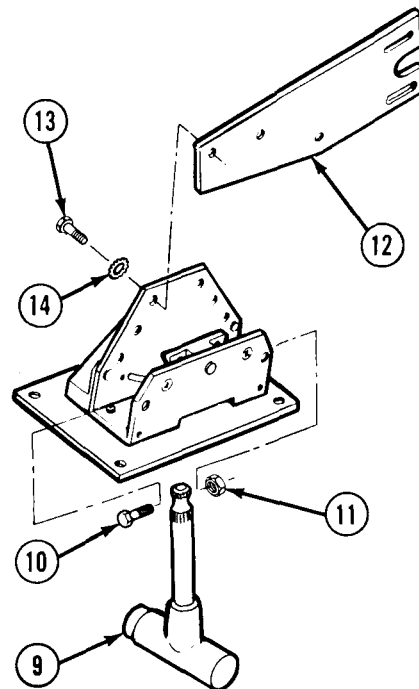

TA189760

Transmission Maintenance Instructions (Cont)

- (8) Install angle bracket (15) with two screws (16) and nuts (17).

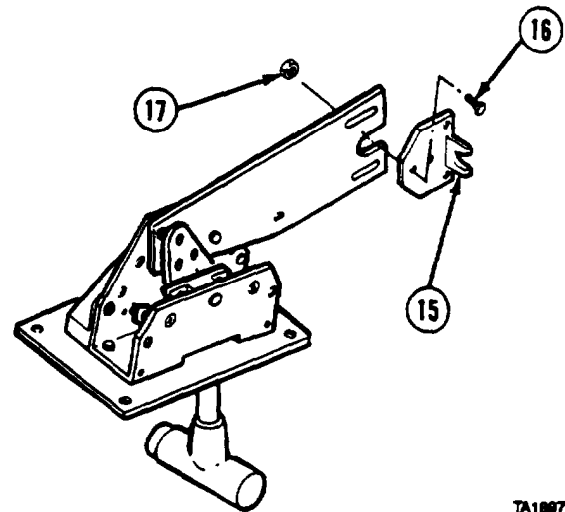

TA188761

- (9) Install switch (18) with screw (19), washer (20), spacer (21), washer (22), and nut (23).
 (10) Install washer (24) and cotter pin (25).

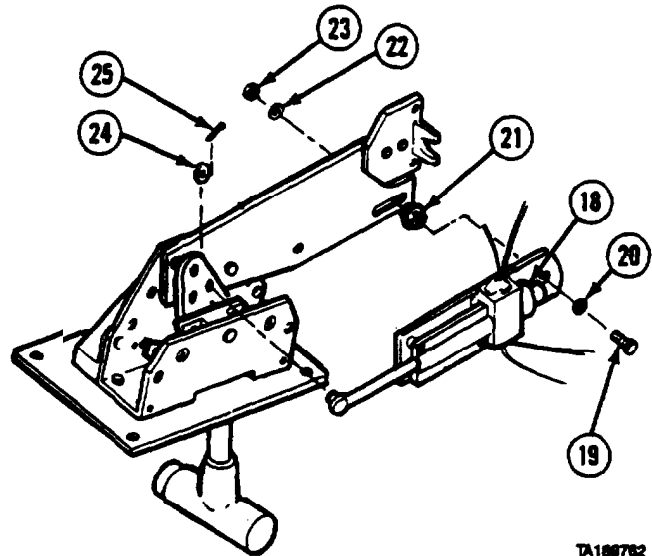

TA188762

d. Follow-on Maintenance.

- (1) Install shift control (TM 9-2320-279-20).
- (2) Install shift cable (TM 9-2320-279-20).
- (3) Adjust neutral safety switch (TM 9-2320-27420).

END OF TASK

Transmission Maintenance Instructions (Cont)

Section IV. TRANSMISSION ASSEMBLY

7-4. TRANSMISSION REMOVAL/INSTALLATION.

This task covers:

- a. Removal
- b. Installation
- c. Follow-on Maintenance

INITIAL SETUP

Models

All

Test Equipment

None

Special Tools

None

Supplies

Antifreeze, permanent, glycol, inhibited, Item 10, Appendix C.
 Compound, sealing, thread locking, Item 26, Appendix C.
 Compound, sealing, pipe thread, Item 29, Appendix C
 Oil, lubricating, Item 47, Appendix C
 Tags, identification, Item 60, Appendix C
 Wood block, 4x6x40 in. (102x152x1016 mm), Item 69, Appendix C

Personnel Required

MOS 63W, Wheel vehicle repairer (2)

References

None

Equipment Condition

<i>TM or Para</i>	<i>Condition Description</i>
TM 9-2320-279-10	Transmission and transfer case set to Neutral.
TM 9-2320-279-20	Batteries disconnected.
TM 9-2320-279-10	Spare tire removed.
TM 9-2320-279-10	Engine side panels removed.
TM 9-2320-279-20	Engine cover removed.

Equipment Condition (cont)

<i>TM or Para</i>	<i>Condition Description</i>
TM 9-2320-279-20	Cargo body front panel removed (M977, M985).
Para 15-9	Cargo body floor panel removed (M977, M985).
TM 9-2320-279-20	Fuel can stowage box removed (M978).
TM 9-2320-279-20	30 KW generator removed (M983).
TM 9-2320-279-20	Rear decking removed (M983 without crane).
Para 15-6	Cargo body removed (M984).
TM 9-2320-279-20	Right and left rear splash guards removed.
TM 9-2320-279-20	Hydraulic reservoir drained.
TM 9-2320-279-20	Transmission fluid drained.
TM 9-2320-279-20	Air system drained.
TM 9-2320-279-20	Coolant system lowered.
Para 13-6	Lift bracket assemblies removed.

Special Environmental Conditions

None

General Safety Instructions

Wheels chocked.

Level of Maintenance

Direct Support.

Transmission Maintenance Instructions (Cont)

a. Removal.

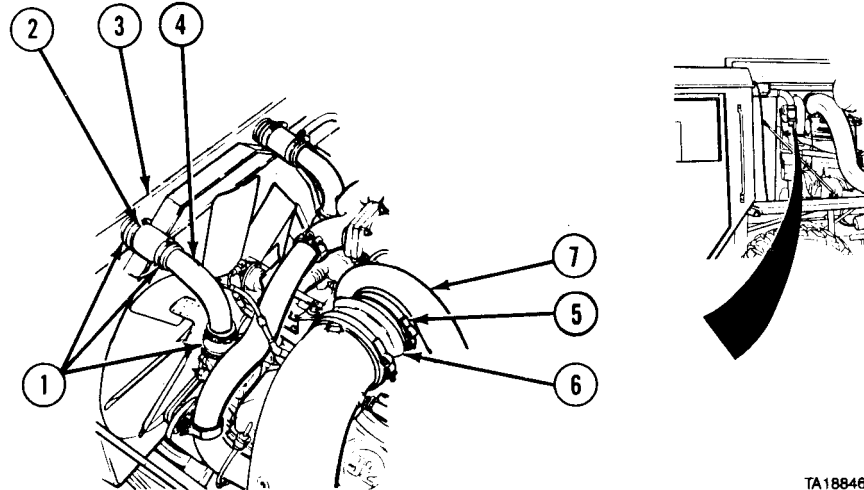

TA188462

NOTE

- Tag and mark all hoses before removal.
- Repeat steps (1) through (3) for right side coolant tube.

- (1) Loosen three clamps (1).
- (2) Remove radiator hose (2) from radiator (3).
- (3) Turn coolant tube (4) away from radiator (3).
- (4) Loosen clamp (5) and remove intake pipe (6) from turbocharger (7).

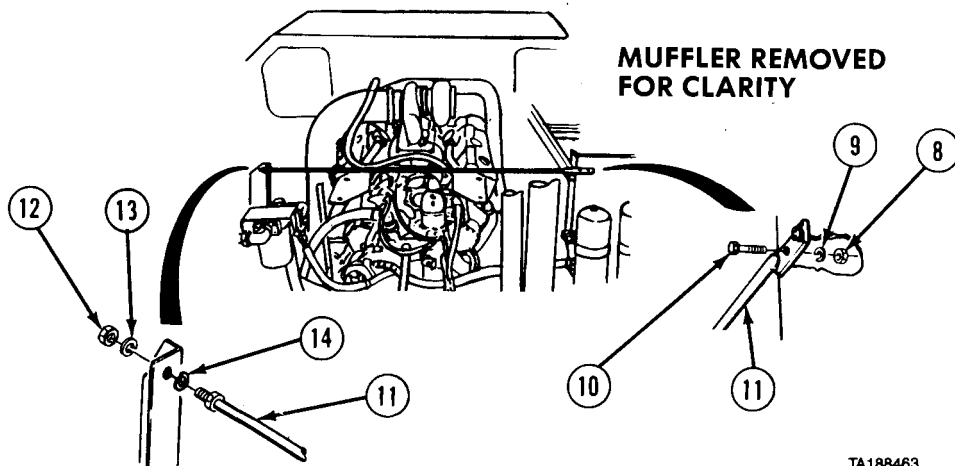

TA188463

- (5) Remove two nuts (8), lockwashers (9), and screws (10) from cross brace (11).
- (6) Remove nut (12) and lockwasher (13) from cross brace (11).
- (7) Remove cross brace (11) and lockwasher (14).

Transmission Maintenance Instructions (Cont)

7-4. TRANSMISSION REMOVAL/INSTALLATION (CONT).

NOTE

- Tag and mark all hoses and fittings.
- Do steps (8) through (17) for M984E1. Go to step (18) for other vehicles.

- (8) Disconnect hose (15) from fitting (16) on pump (17).
 (9) Disconnect hose (18) from fitting (19).
 (10) Disconnect hose (20) from fitting (21).

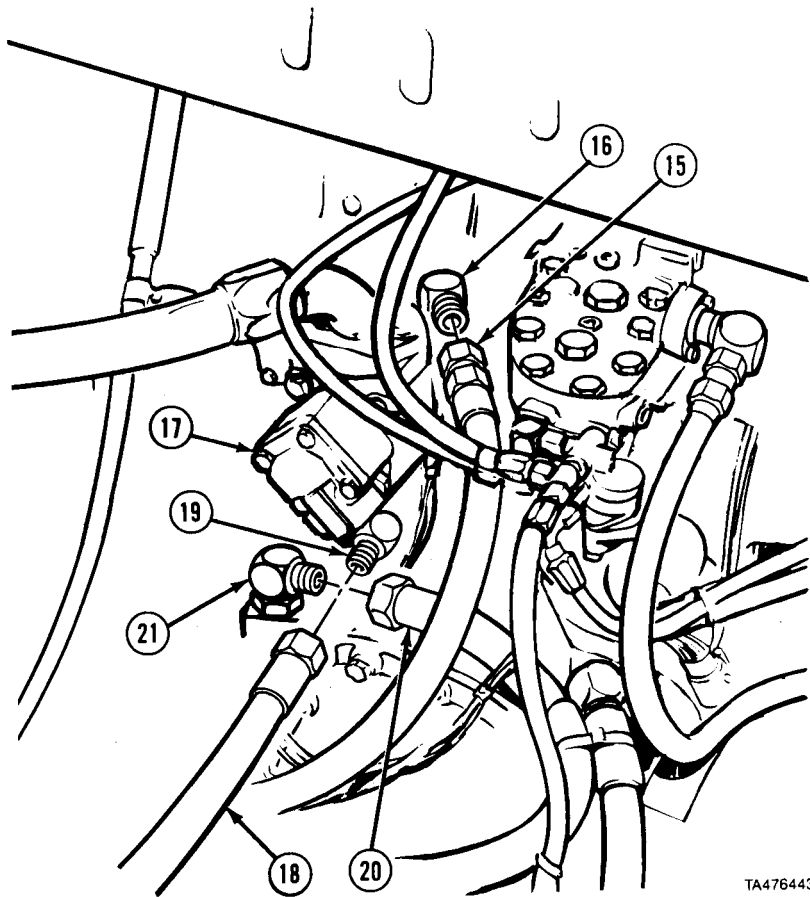

TA476443

- (11) Remove valve (22) from heavy-duty winch manifold valve (23).
 (12) Disconnect hose (24) from fitting (25) on heavy-duty winch manifold valve (23).
 (13) Install valve (22), but do not tighten.
 (14) Disconnect hose (26) from fitting (27) on heavy-duty winch manifold valve (23).
 (15) Disconnect two hoses (28) from fittings (29).
 (16) Disconnect two hoses (30) from fittings (31).
 (17) Disconnect hose (32) from fitting (33).

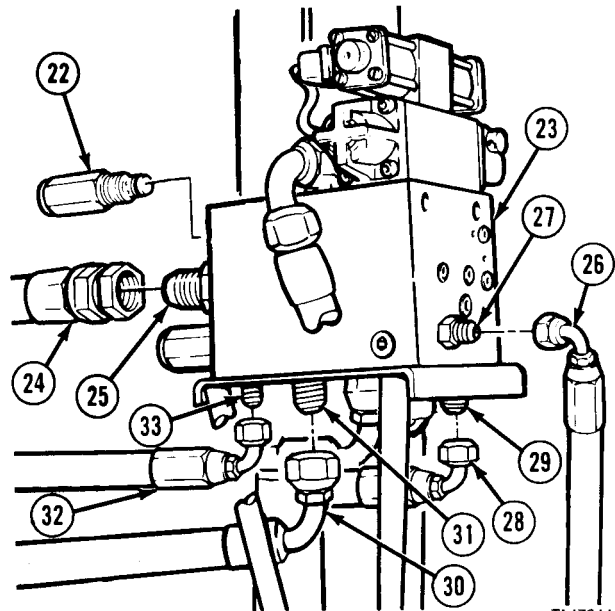

TA476444

Transmission Maintenance Instructions (Cont)

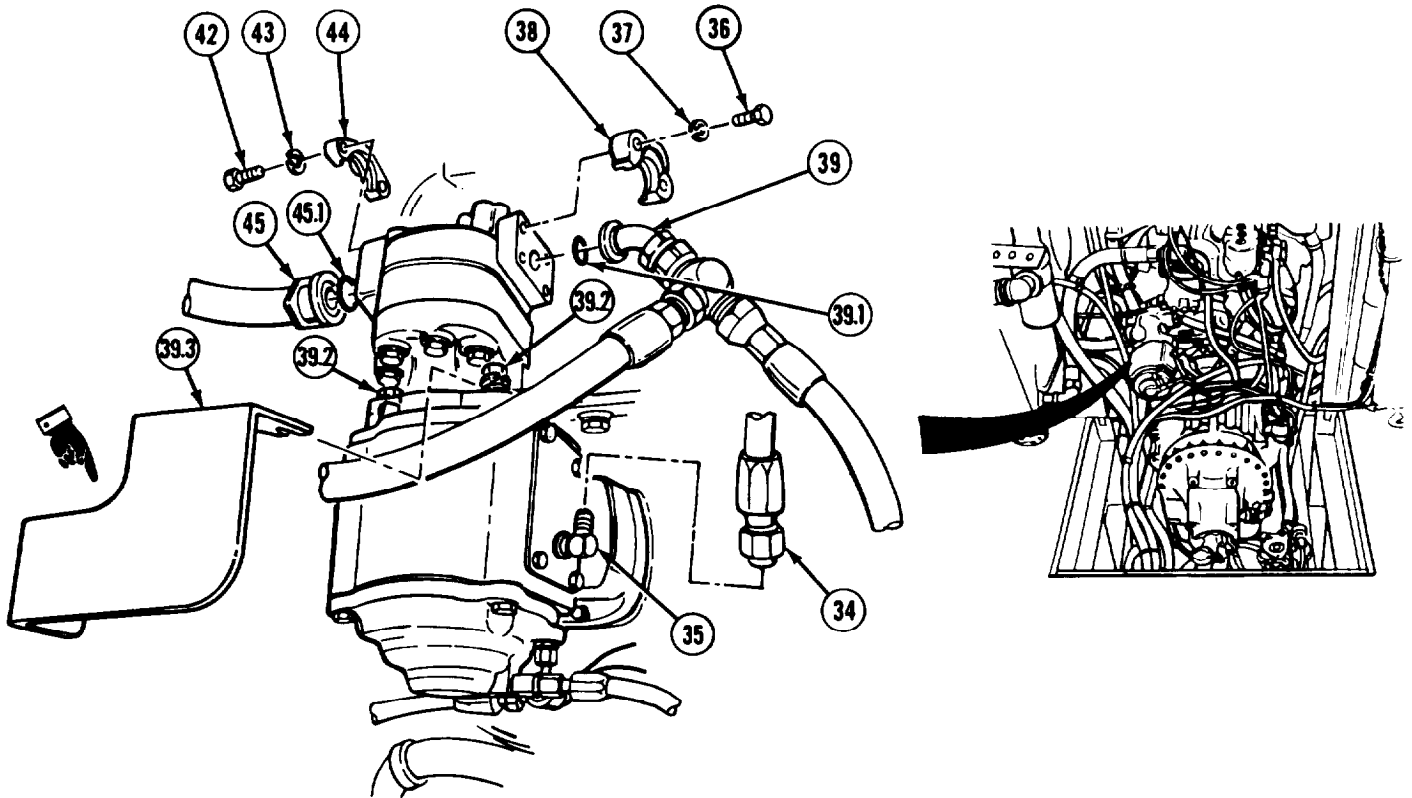

NOTE

Go to step (22) when removing transmission on M984E1.

- (18) Disconnect hose (34) from fitting (35).
- (19) Remove four screws (36), lockwashers (37), and two clamp halves (38), and move fitting (39) with preformed packing (39.1) aside.

NOTE

Trucks with guard, perform step (19.1). Trucks without guard, proceed to step (21).

- (19.1) Loosen two screws (39.2) and remove guard (39.3).
- (20) Deleted.
- (21) Remove four screws (42), lockwashers (43), two clamp halves (44), hose (45), and preformed packing (45.1).

Transmission Maintenance Instructions (Cont)

(22) Disconnect hose (46) from governor (47).

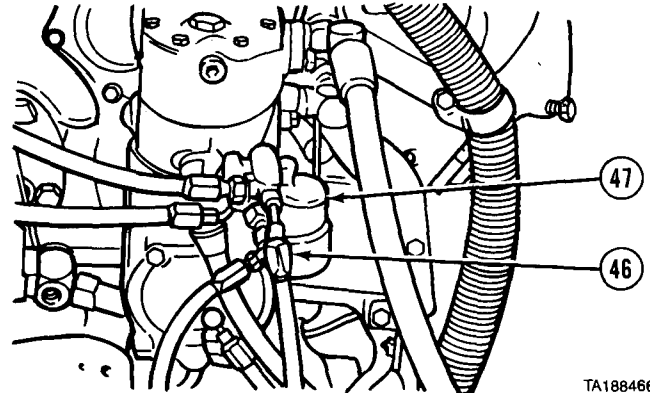

TA188466

(23) Disconnect oil cooler hose (48) from elbow (49).

(24) Disconnect STE/ICE connector (50) from connector (51).

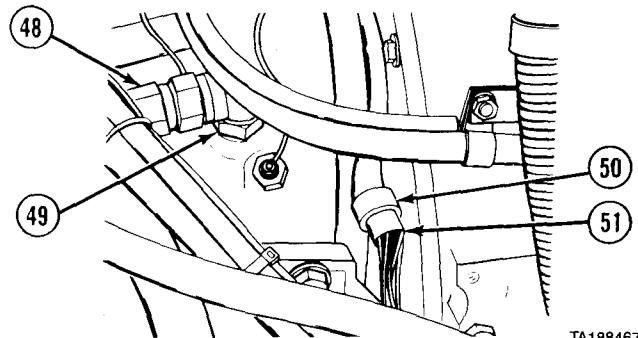

TA188467

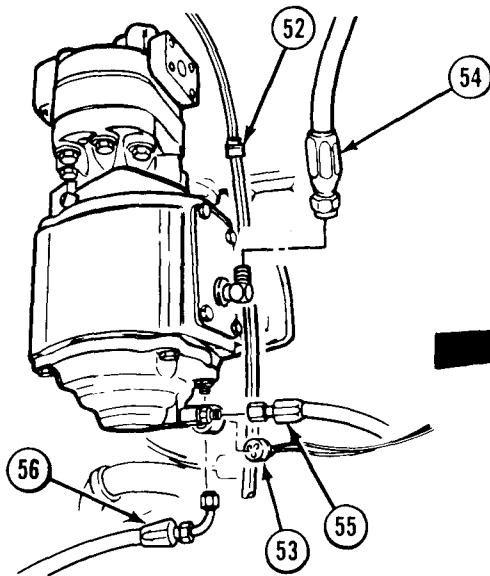

(25) Disconnect plug (52).

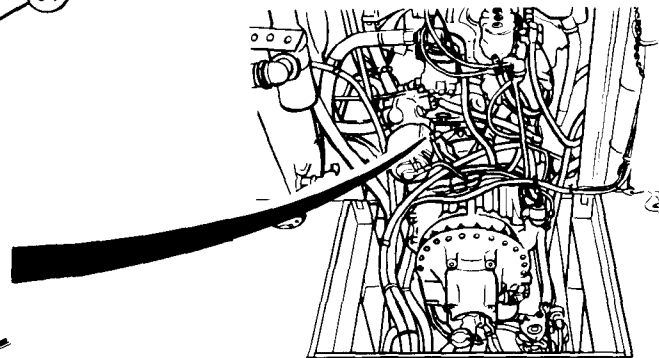

TA188468

NOTE

Go to step (28) when removing transmission on M984E1.

(26) Disconnect plug (53).

(27) Disconnect three hoses (54, 55, and 56).

Transmission Maintenance Instructions (Cont)

7-4. TRANSMISSION REMOVAL/INSTALLATION (CONT).

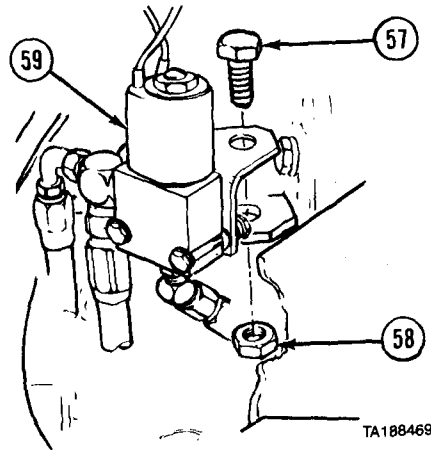

- (28) Remove screw (57) and locknut (58) from solenoid assembly (59).
- (29) Move solenoid assembly (59) aside.

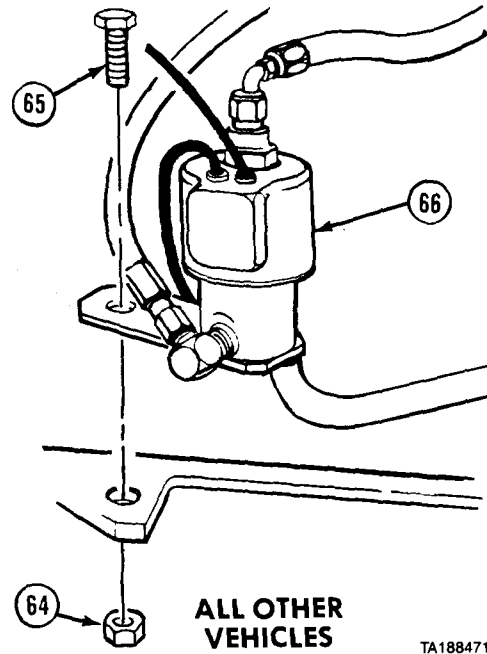
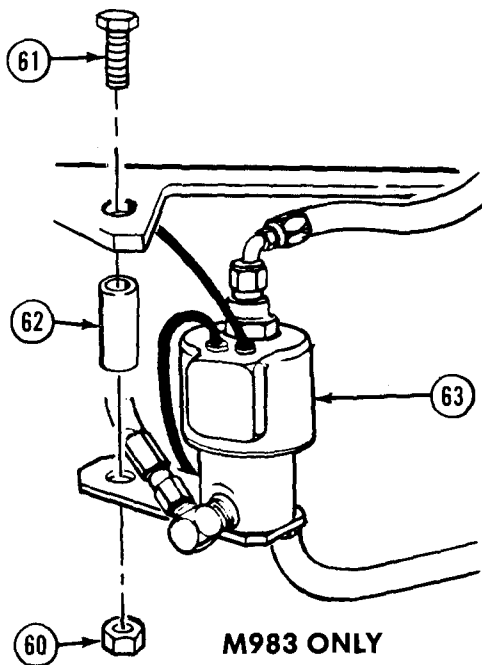

NOTE

Step (30) is for M983 vehicles only.

- (30) Remove locknut (60), screw (61), spacer (62), and solenoid assembly (63).

NOTE

Steps (31) and (32) are for all models except M983.

- (31) Remove locknut (64) and screw (65) from solenoid assembly (66).
- (32) Move solenoid assembly (66) aside.

Transmission Maintenance Instructions (Cont)

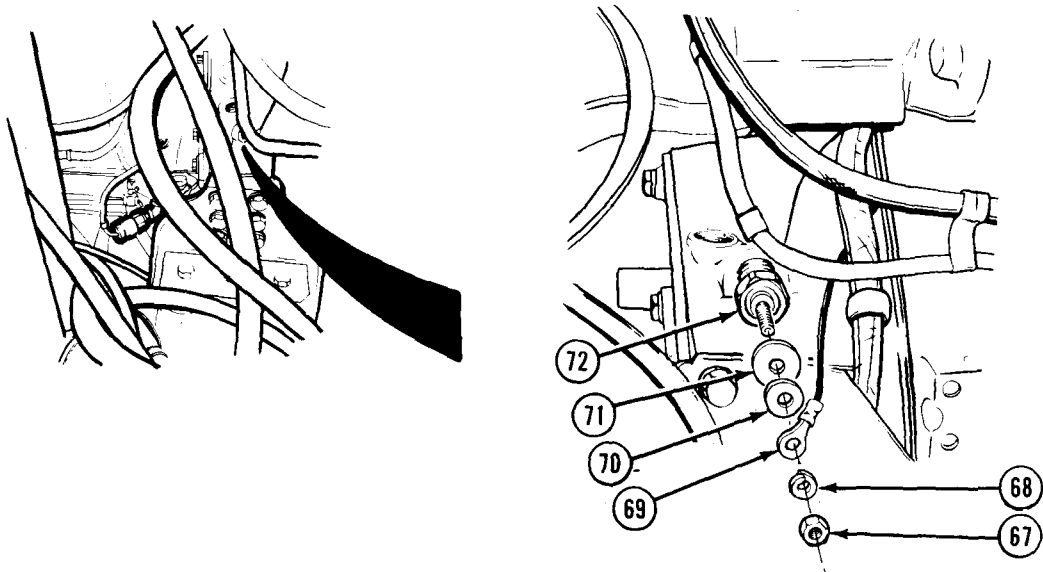

TA188472

- (33) Remove nut (67), lockwasher (68), wire (69), washer (70), and insulating washer (71) from transmission temperature sending unit (72).

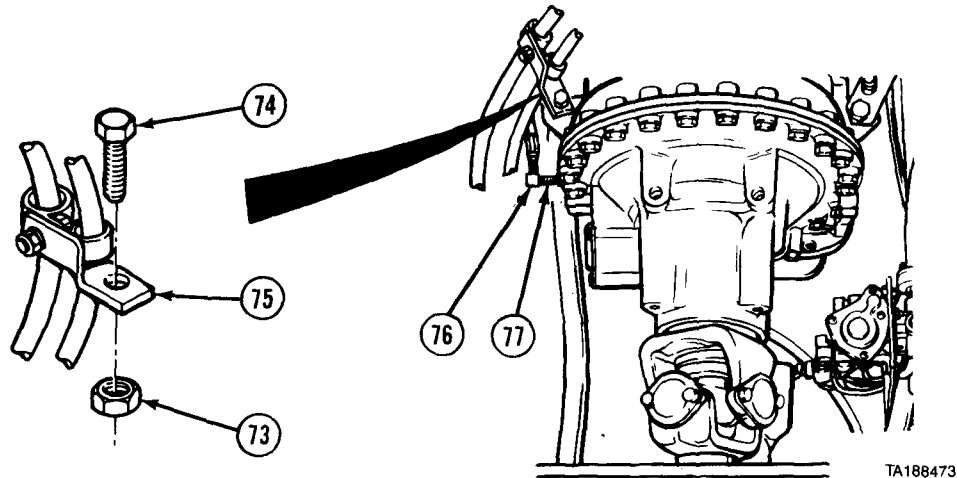

TA188473

NOTE

M984E1 has only one hose on bracket.

- (34) Remove locknut (73) and screw (74). Move bracket (75) aside.
 (35) Disconnect hose (76) from modulator valve (77).

Transmission Maintenance Instructions (Cont)

7-4. TRANSMISSION REMOVAL/INSTALLATION (CONT).

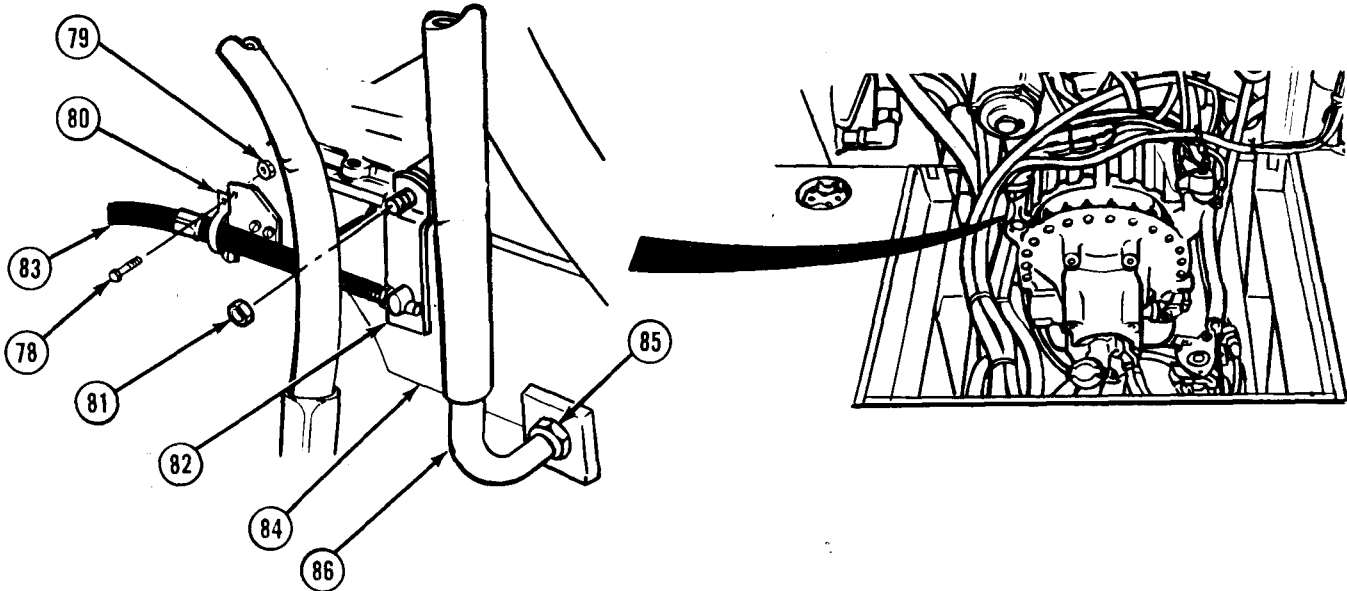

TA188474

- (36) Remove two screws (78), nuts (79), and clamp (80).
- (37) Remove nut (81) and shift lever (82).
- (38) Remove shift cable (83) from transmission oil pan (84).
- (39) Loosen fitting (85) and move dipstick (86) aside.

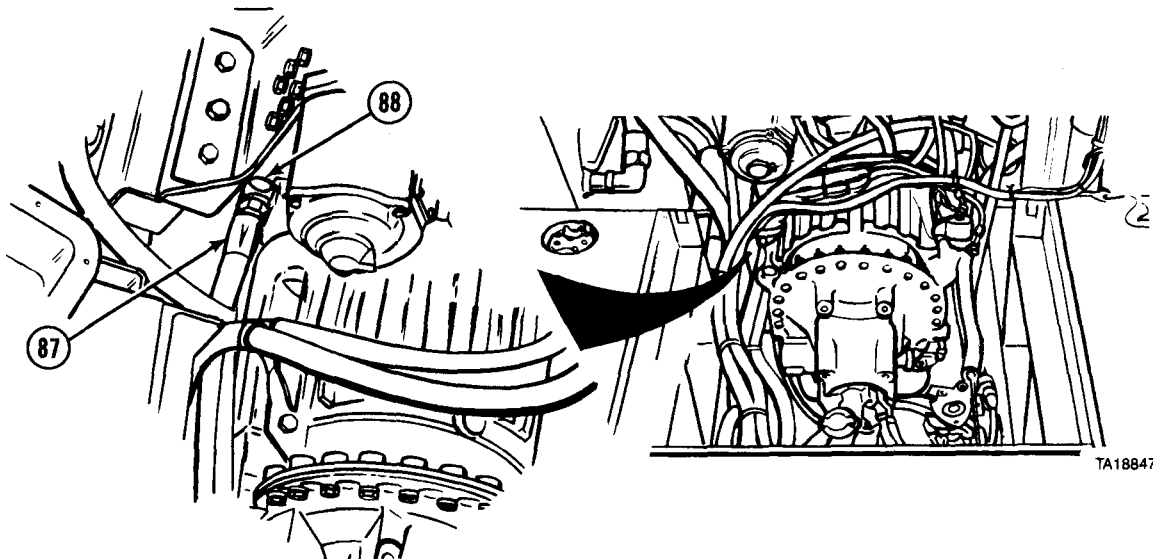

TA188475

- (40) Disconnect hose (87) from fitting (88).

Transmission Maintenance Instructions (Cont)

- (41) Disconnect electrical plug (89) from connector (90).
- (42) Remove three hoses (91, 92, and 93) from fittings (94, 95, and 96).

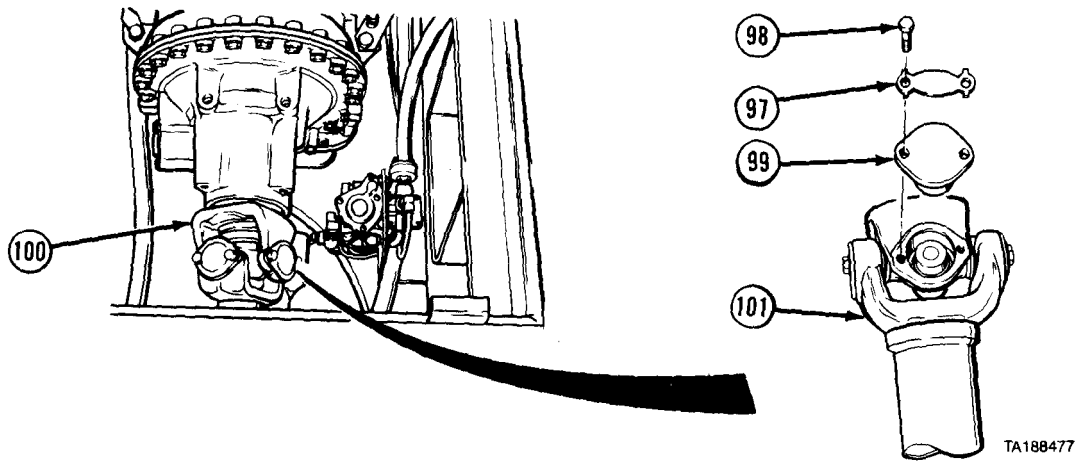
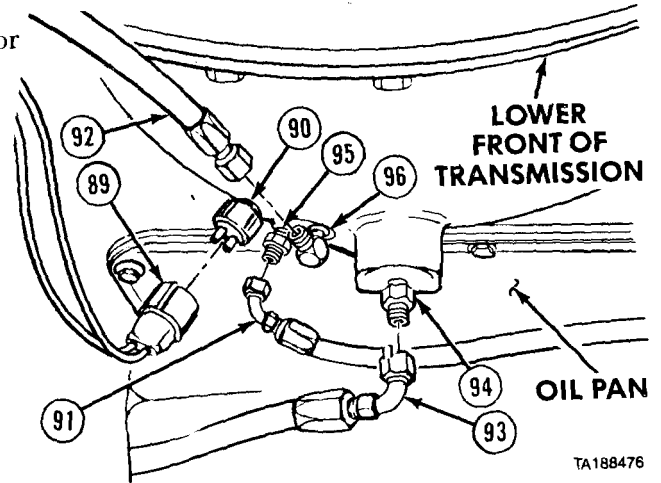

- (43) Bend tabs of lockstrap (97) away from two screws (98).
- (44) Remove two screws (98) and lockstrap (97) from two bearing retainer caps (99).
- (45) Remove bearing retainer caps (99) from both sides of transmission yoke (100).
- (46) Move propeller shaft (101) out of way.

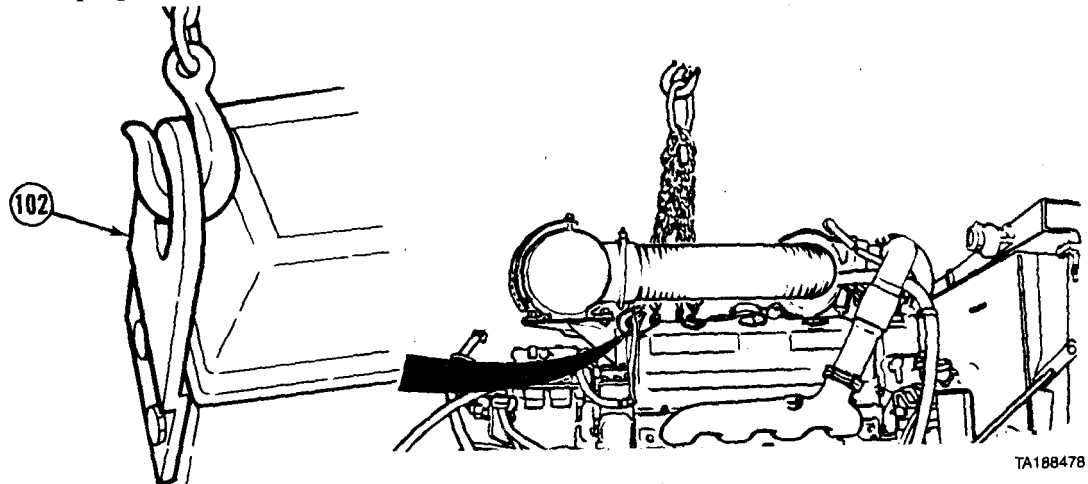

- (47) Attach lifting device to two rear engine lifting eyes (102).

Transmission Maintenance Instructions (Cont)

7-4. TRANSMISSION REMOVAL/INSTALLATION (CONT).

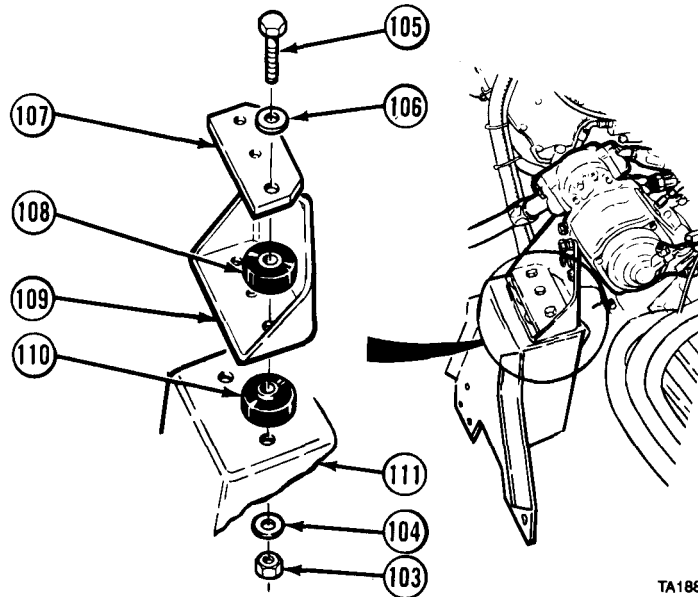

TA188479

(48) Remove three locknuts (103), washers (104), screws (105), washers (106), one plate (107), and three mounting biscuits (108) from left and right transmission mounts (109).

NOTE

Lift rear of transmission with lifting device.

(49) Remove three mounting biscuits (110) from left and right transmission brackets (111).

NOTE

Support block dimensions should be about 4-to-6 in. (102 to 152 mm) thick and 40-in. (1 016 mm) long.

(50) Soldier A slides wood block under engine and across vehicle frame while Soldier B operates suitable lifting device and lowers engine on support block. Remove lifting device.

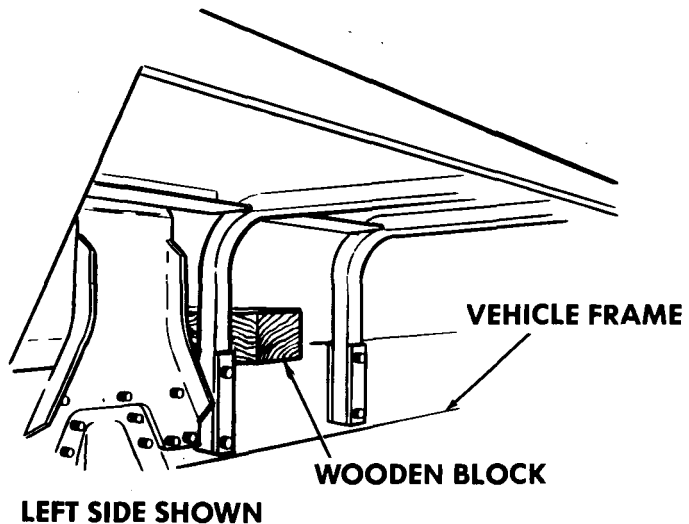

TA188480

Transmission Maintenance Instructions (Cont)

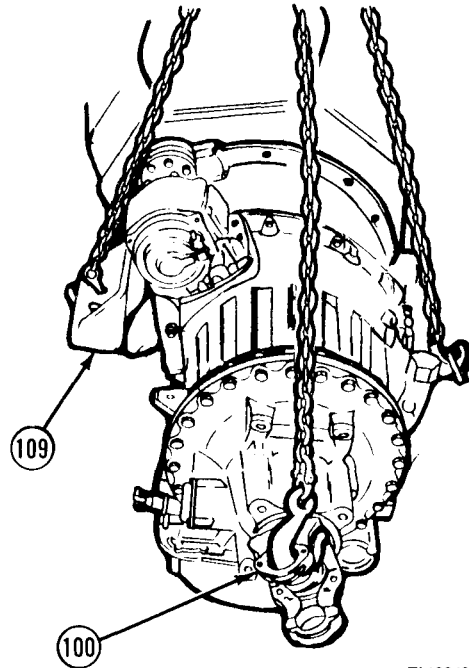

TA188481

WARNING

Keep out from under heavy parts. Falling parts may cause serious injury or death.

- (51) Hook two ends of lifting device to mounting hole on right and left transmission mounts (109).
- (52) Hook third end of lifting device to transmission yoke (100).

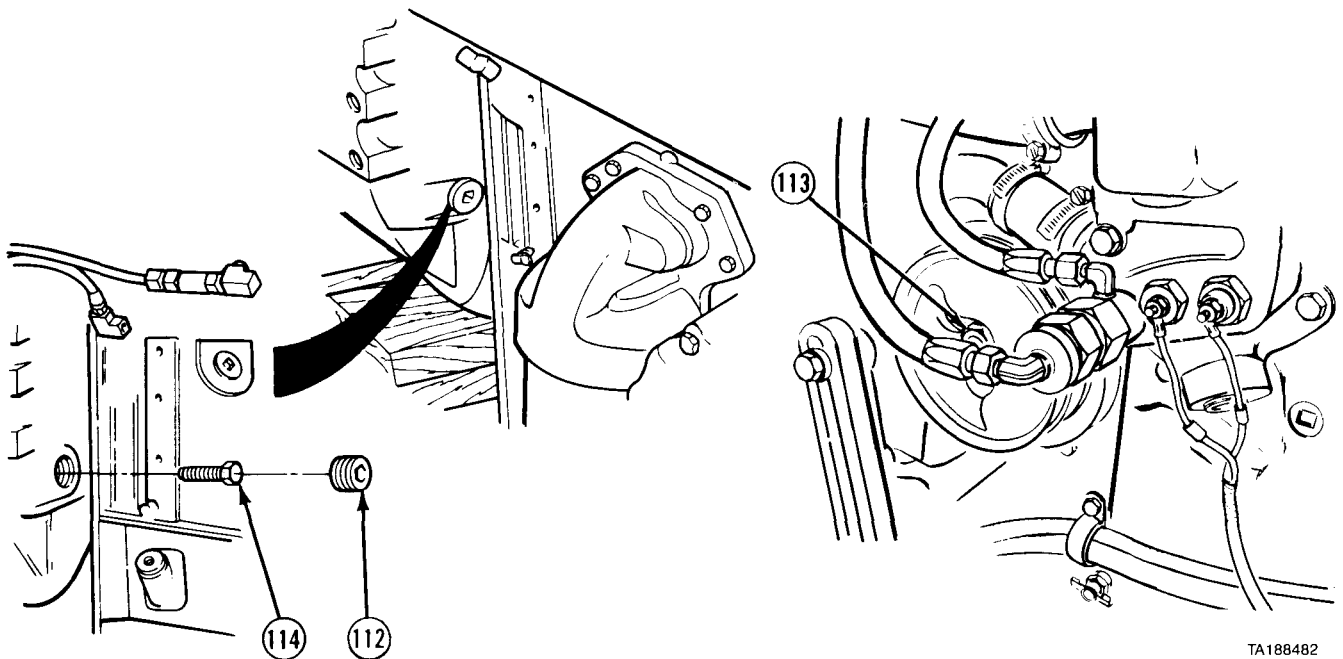

TA188482

- (53) Remove access hole plug (112).
- (54) Soldier A looks in access hole while Soldier B turns pulley nut (113) clockwise until Soldier A sees head of screw centered in hole.
- (55) Remove 12 screws (114).

Transmission Maintenance Instructions (Cont)

7-4. TRANSMISSION REMOVAL/INSTALLATION (CONT).

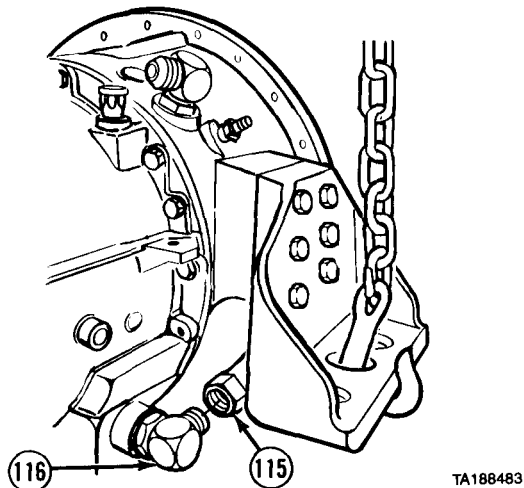

(56) Disconnect hose (115) from elbow (116).

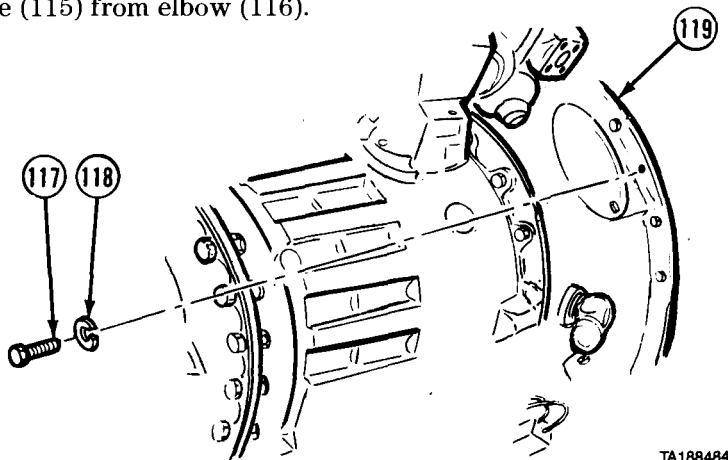

(57) Remove 24 screws (117) and lockwashers (118) from housing (119).

WARNING

Keep out from under heavy parts.
Falling parts may cause serious injury or death.

CAUTION

Be sure transmission, brackets, and lifting device are clear of all hoses and harnesses to prevent damage to equipment.

(58) Soldier A guides transmission (120) away from engine (121) while Soldier B operates suitable lifting device.

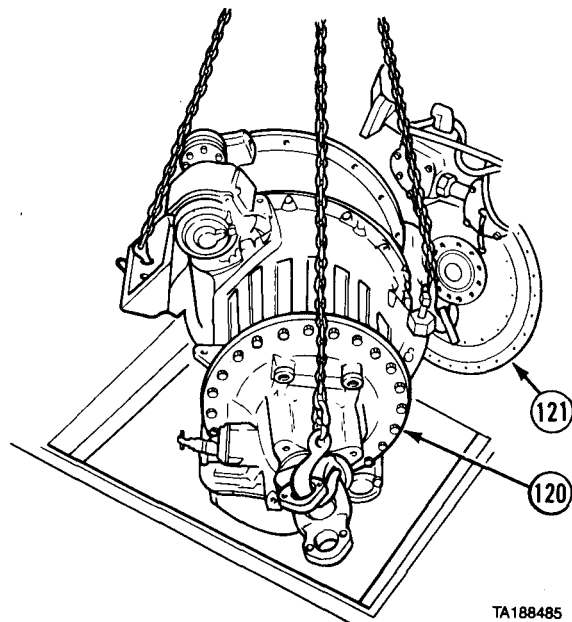

Transmission Maintenance Instructions (Cont)

NOTE

- Left and right side mounting brackets are removed the same. Left side is shown.
 - Tag and mark mounting brackets.
- (59) Remove six screws (122), lockwashers (123), and transmission mount (109).

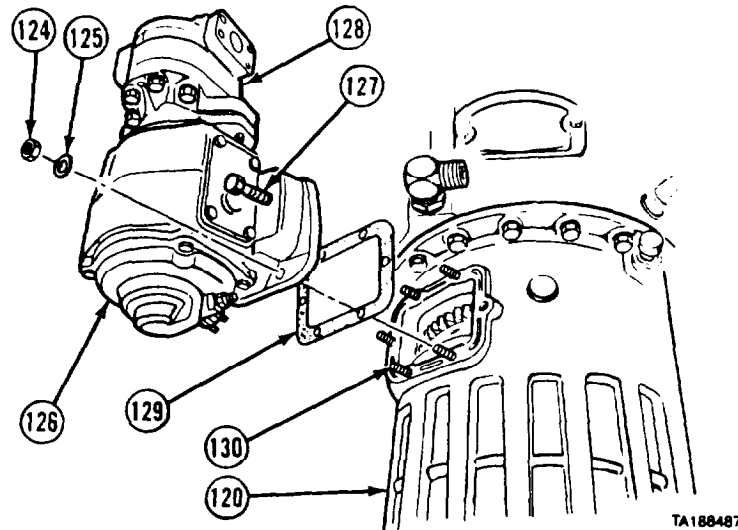
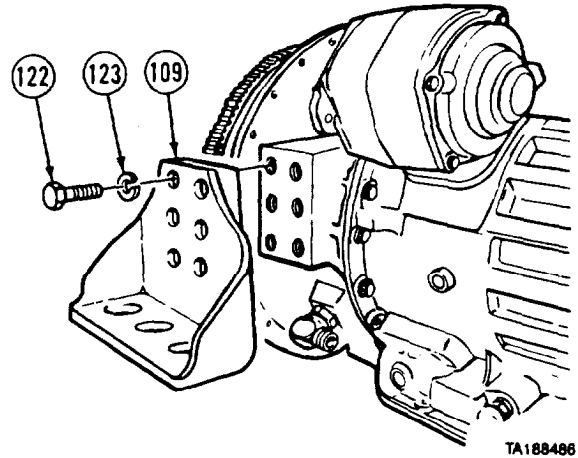

NOTE

Skip steps (61) through (64) for M984E1.

- (60) Remove five nuts (124) and washers (125) from base of FY10 (126).
 (61) Remove screw (127).
 (62) Remove PTO (126) and hydraulic pump (128) from transmission (120).

CAUTION

Access hole must be covered to prevent dust and dirt from entering transmission and causing damage to equipment.

- (63) Remove gasket (129) from transmission (120). Cover transmission access hole (130).

NOTE

- All components removed in this procedure must be installed on replacement (new) transmission.
- Refer to paragraph 23-9 if transmission is to be prepared for storage.

Transmission Maintenance Instructions (Cont)

7-4. TRANSMISSION REMOVAL/INSTALLATION (CONT.)

b. Installation

NOTE

- Refer to paragraph 23-9 if transmission must be unpacked from container.
- Install fittings, sending units, and plugs from old transmission on new transmission.
- Skip steps (1) through (3) when installing transmission on M984E1.
- Uncover access hole before doing step (1).

- (1) Install gasket (1) on transmission access hole (2).
- (2) Install hydraulic pump (3) and PTO (4) on transmission (5) with five nuts (6), washers (7), and screw (8).
- (3) Tighten nuts (6) and screw (8) to 30 to 35 lb-ft (41 to 48 N•m).

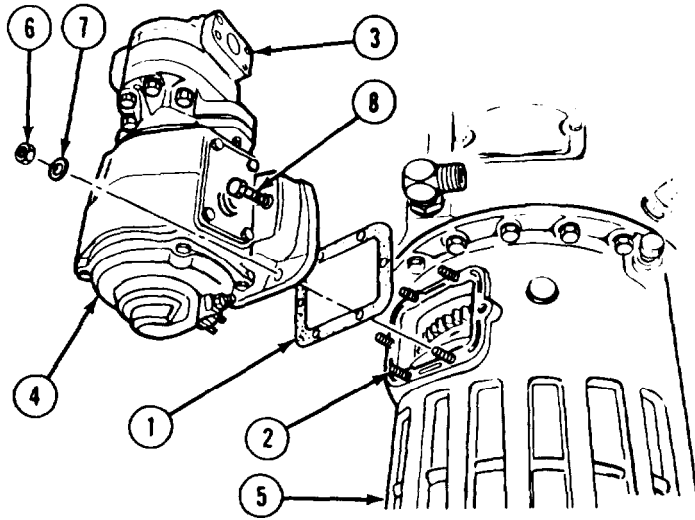

WARNING

Adhesives, solvents, and sealing compounds can burn easily, can give off harmful vapors, and are harmful to skin and clothing. To avoid injury or death, keep away from open fire and use in well-ventilated area. If adhesive, solvent, or sealing compound gets on skin or clothing, wash immediately with soap and water.

- (3.1) Apply thread locking sealing compound to threads of six screws (11).

NOTE

Left and right mounting brackets are installed the same. Left side is shown.

- (4) Install transmission mount (9) with six lockwashers (10) and screws (11). Tighten screws to 130 to 140 lb-ft (176 to 190 N•m).

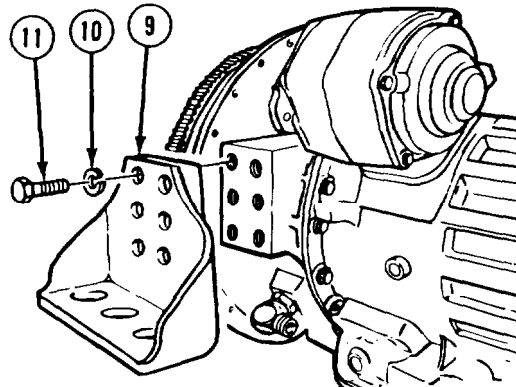

WARNING

Keep out from under heavy parts. Falling parts may cause serious injury or death.

- (5) Hook one chain of lifting device to transmission yoke (12) and chains to left and right transmission mounts (9 and 13).

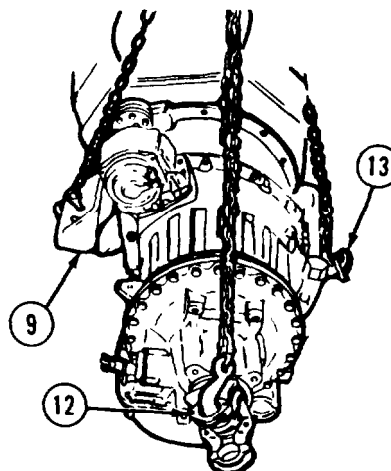

Transmission Maintenance Instructions (Cont)

WARNING

Keep out from under heavy parts. Falling parts may cause serious injury or death.

CAUTION

Be sure transmission, brackets, and lifting device are clear of all hoses and harnesses to prevent damage to equipment.

- (6) Soldier A guides transmission (5) onto vehicle while Soldier B operates suitable lifting device.

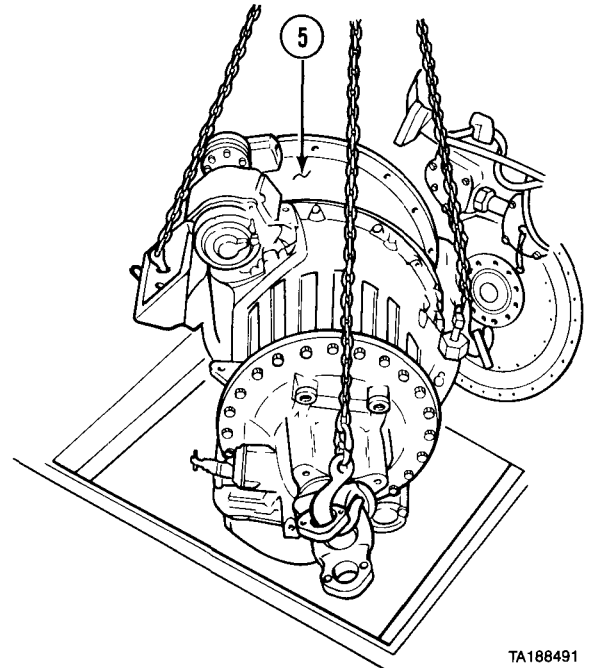

TA188491

- (7) Install 24 screws (14) and lockwashers (15) in housing (16).

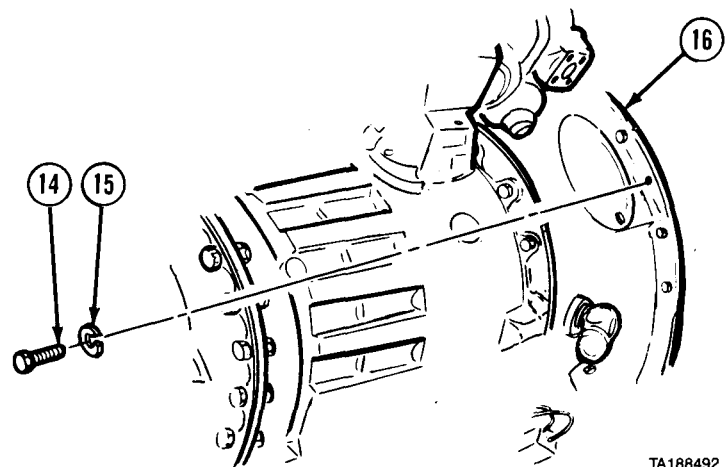

TA188492

Transmission Maintenance Instructions (Cont)

7-4. TRANSMISSION REMOVAL/INSTALLATION (CONT).

- (8) Remove two screws (17).
- (9) Remove access cover (18) and gasket (19).

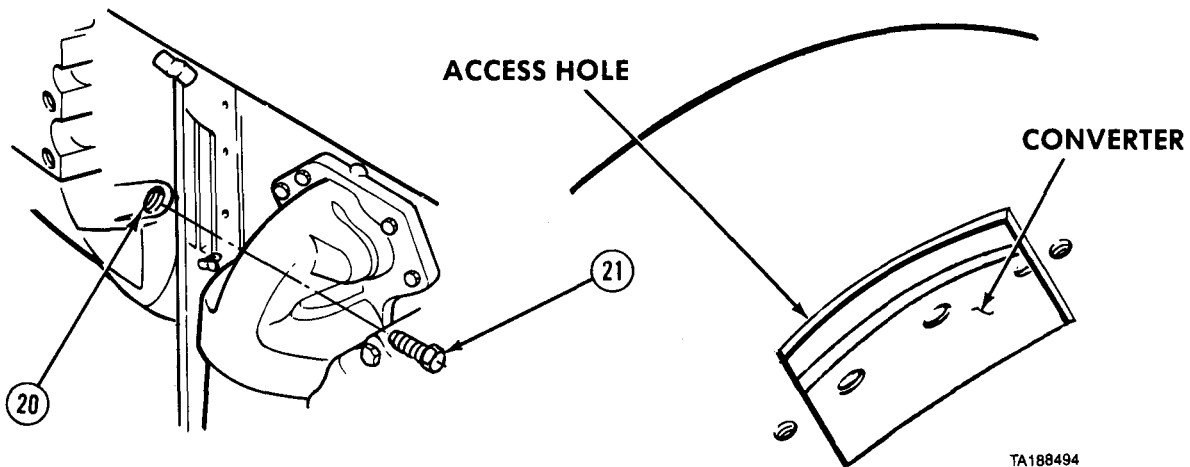
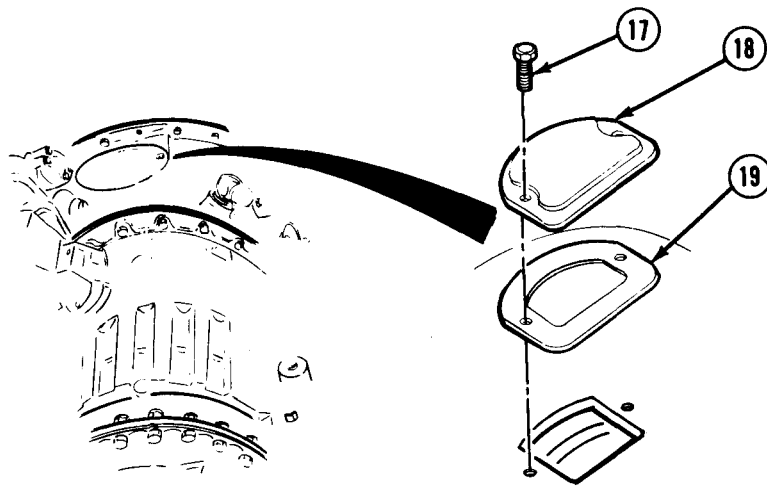

- (10) Soldier A looks in access hole (20) while Soldier B reaches through access hole and turns converter to align holes in flywheel.
- (11) Install screw (21). Do not fully tighten.

Transmission Maintenance Instructions (Cont)

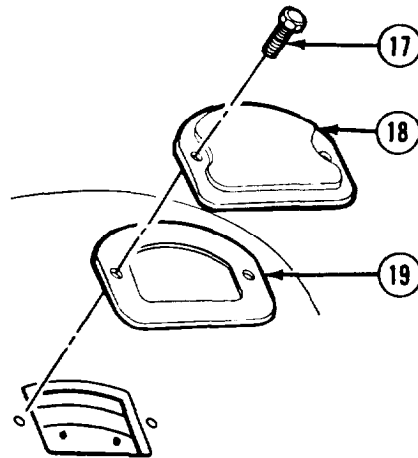

- (12) Install gasket (19) and access cover (18) with two screws (17).

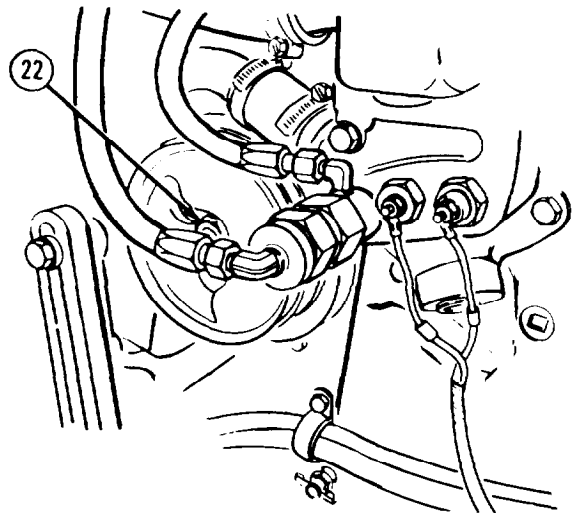
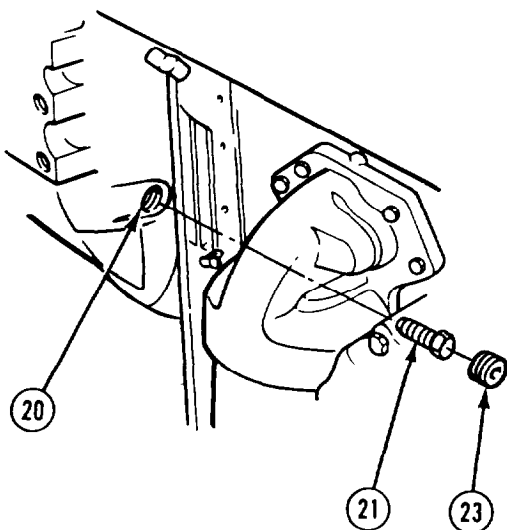
**NOTE**

Do steps (13) and (14) until 12 screws are installed.

- (13) Soldier A looks in access hole (20) while Soldier B turns pulley nut (22) clockwise.
 (14) When screw hole is centered, Soldier A tells Soldier B to stop turning pulley nut (22) and Soldier A installs remaining 11 converter screws (21). Do not tighten.
 (15) Tighten 12 screws (21) to 105 to 115 lb-ft (142 to 156 N•m).
 (16) Apply pipe thread sealing compound to plug (23) and install plug (23).

Transmission Maintenance Instructions (Cont)

7-4. TRANSMISSION REMOVAL/INSTALLATION (CONT).

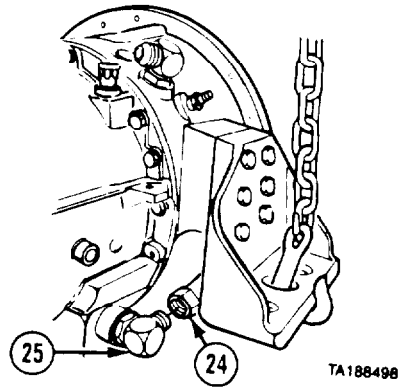
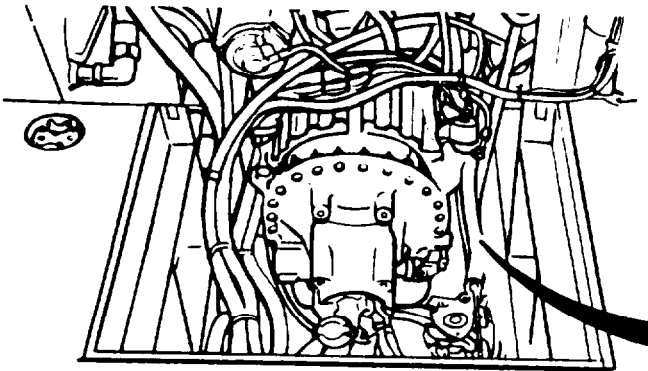

(17) Connect hose (24) to elbow (25).

(18) Remove chains from transmission (5) and attach to engine lifting eyes (26).

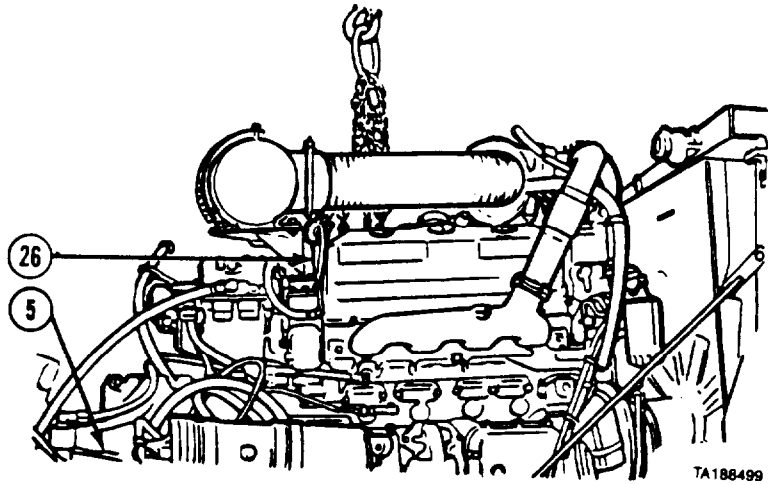

(19) Soldier A installs three mounting biscuits (27) between transmission mount (9) and bracket (28) on each side of transmission (5) while Soldier B operates suitable lifting device.

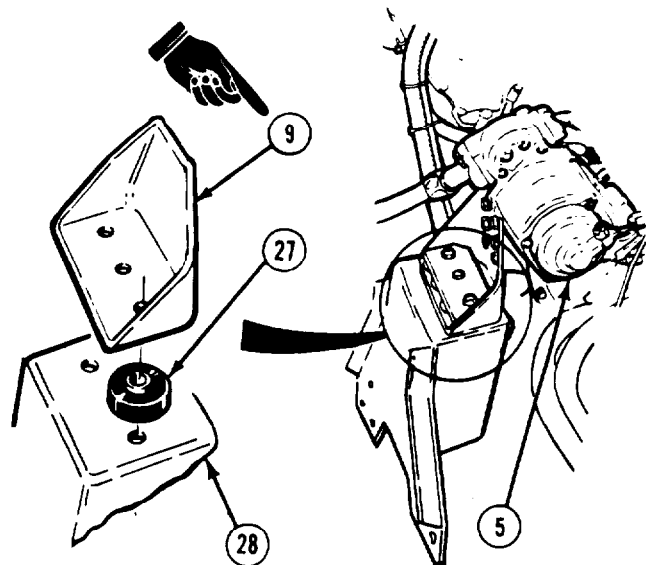

Transmission Maintenance Instructions (Cont)

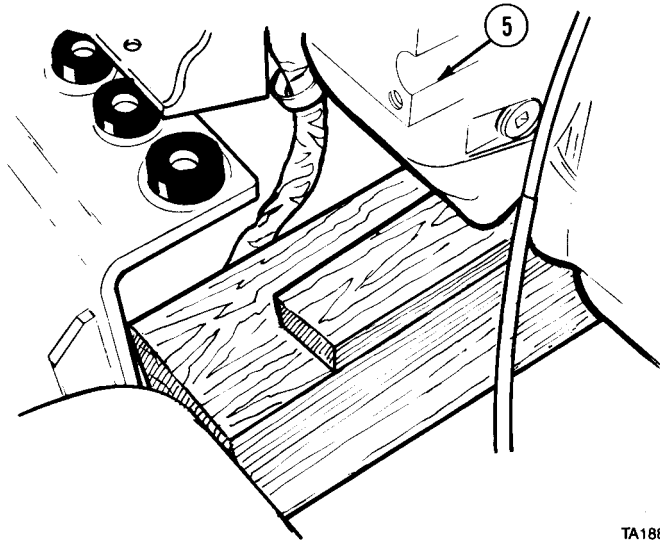

TA188501

(20) Remove wood block.

WARNING

Keep out from under heavy parts. Falling parts may cause serious injury or death.

NOTE

It may be necessary to use a hydraulic jack and a two by four to aline mount holes.

(21) Soldier A alines mounting holes while Soldier B operates lifting device and lowers transmission (5).

(22) Install three mounting biscuits (29) and plate (30).

(23) Lubricate three screws (31) with oil and install with washers (32 and 33) and locknuts (34) on right and left side of transmission. Tighten screws to 170 lb-ft (231 N·m).

(24) Remove lifting device.

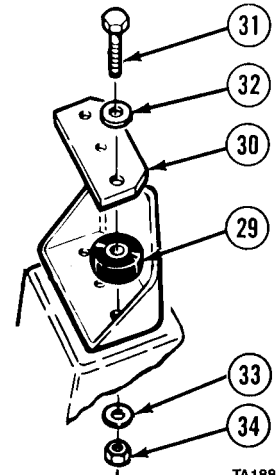

TA188502

Transmission Maintenance Instructions (Cont)

7-4. TRANSMISSION REMOVAL/INSTALLATION (CONT).



TA188503

- (25) Align propeller shaft (35) on transmission yoke (12).
- (26) Install two bearing retainer caps (36) and lockstrap (37) with two screws (38) on both sides of transmission yoke (12). Tighten to 42 lb-ft (57 N·m). Bend tabs of lockstrap (37) over screws (38).



TA188504

- (27) Connect hose (39) to transmission (5).

Transmission Maintenance Instructions (Cont)

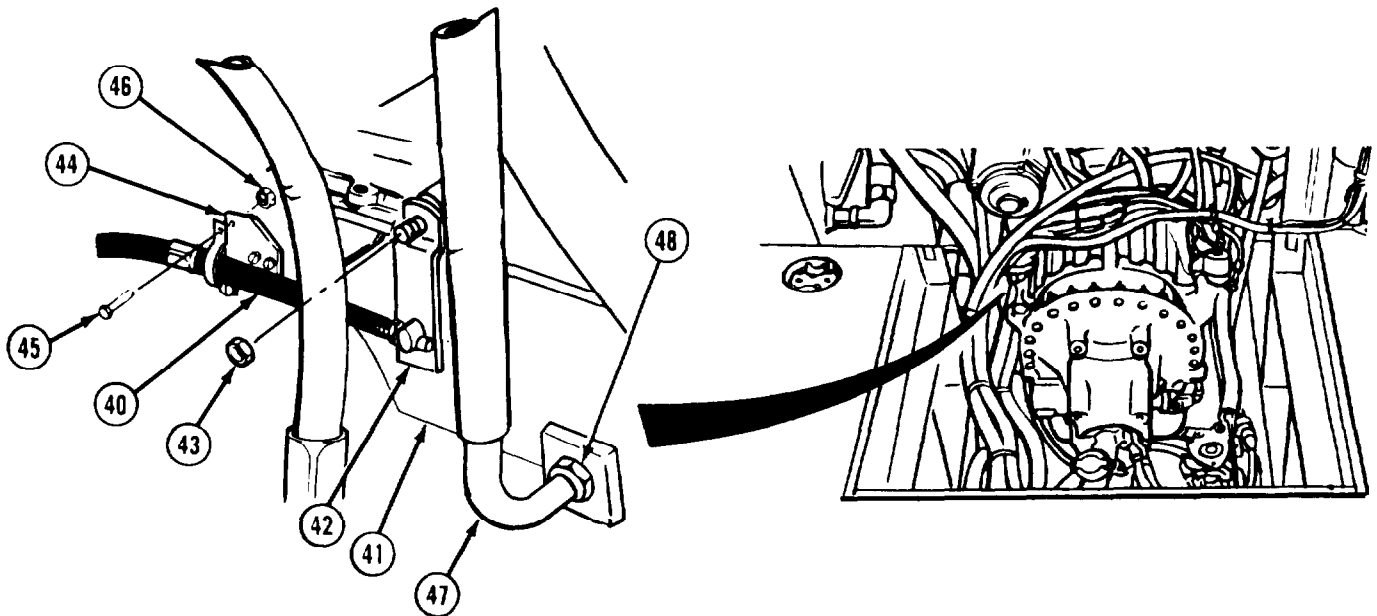

- (28) Position shift cable (40) on transmission oil pan (41).
- (29) Install shift lever (42) with nut (43).
- (30) Install clamp (44) with two screws (45) and nuts (46).
- (31) Install dipstick tube (47) with fitting (48). Tighten fitting to 90 to 100 lb-ft (122 to 136 N•m).
- (32) Connect plug (49).
- (33) Connect three hoses (50, 51, and 52).

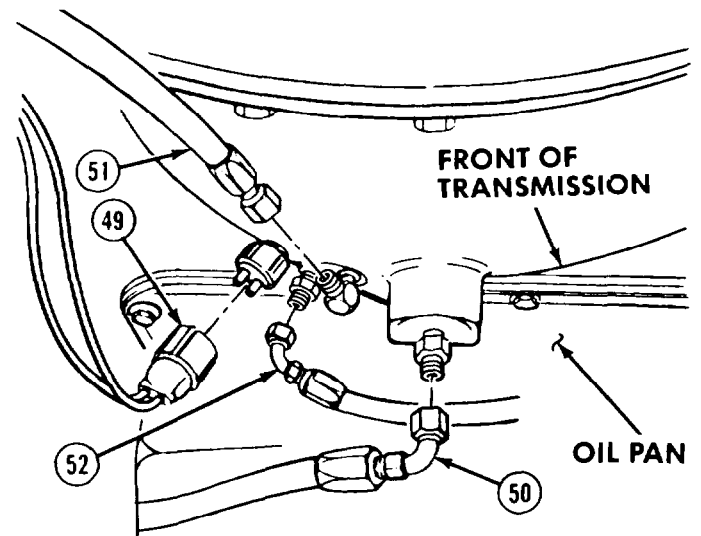

Transmission Maintenance Instructions (Cont)

17-4. TRANSMISSION REMOVAL/INSTALLATION (CONT).

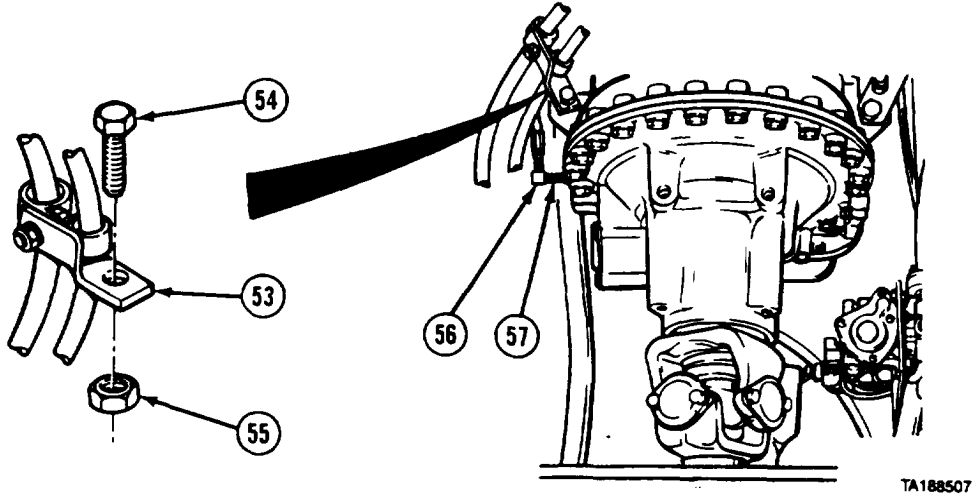

NOTE

M984E1 has one hose on bracket.

- (34) Connect bracket (53) with screw (54) and locknut (55).
- (35) Connect hose (56) to modulator valve (57).

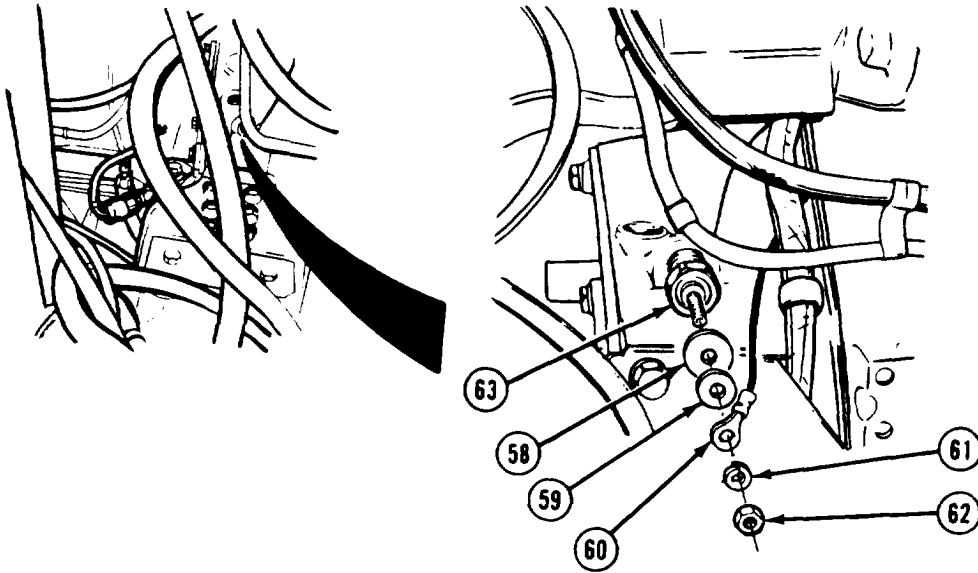

- (36) Install insulating washer (58), washer (59), wire (60), and lockwasher (61) with nut (62) on transmission temperature sending unit (63).

Transmission Maintenance Instructions (Cont)

NOTE

Step (37) is for M983 vehicles only.

- (37) Install screw (64), spacer (65), solenoid assembly (66), and locknut (67).

NOTE

For all models except M983.

- (38) Install screw (64), solenoid assembly (66), and locknut (67).

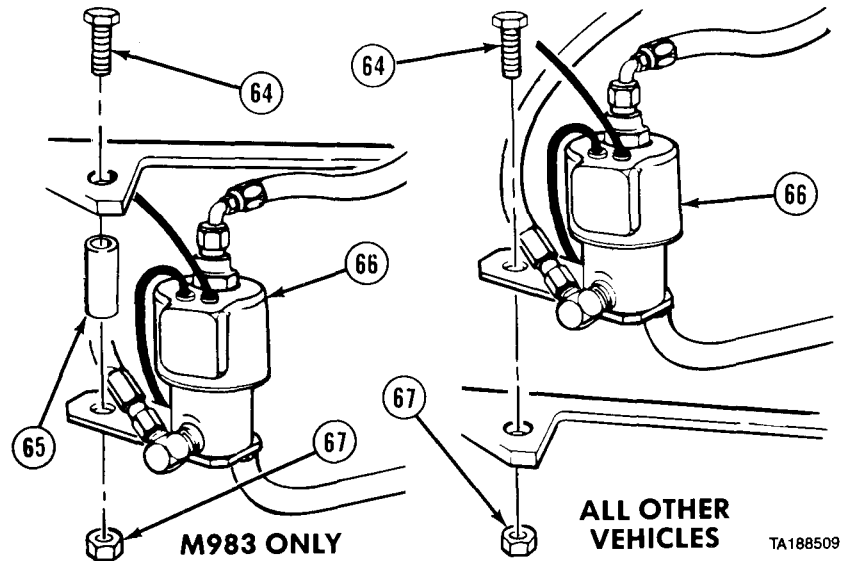

TA188509

NOTE

Use on all models.

- (39) Install solenoid assembly (68) with screw (69) and locknut (70).

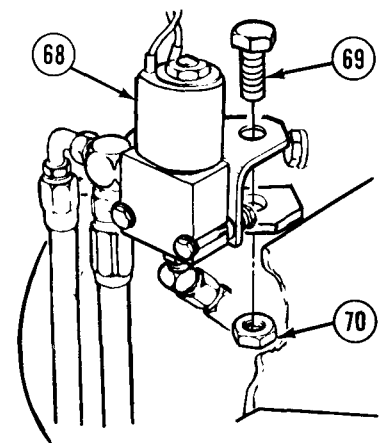

TA188511

NOTE

Go to step (42) when installing transmission on M984E1.

- (40) Connect three hoses (71, 72, and 73).
- (41) Connect plug (74).
- (42) Connect plug (75).

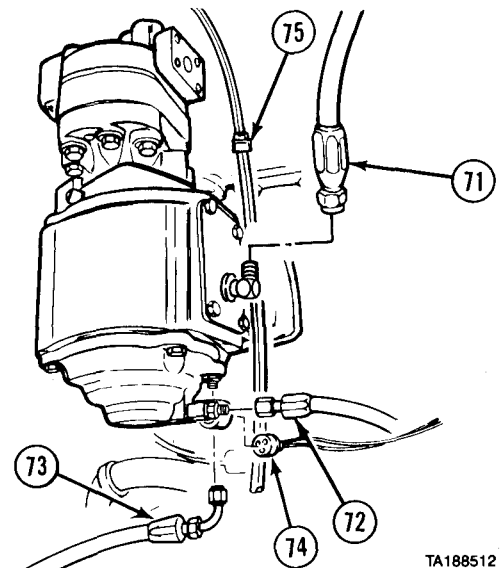

TA188512

Transmission Maintenance Instructions (Cont)

7-4. TRANSMISSION REMOVAL/INSTALLATION (CONT.)

(43) Connect hose (76) to governor (77).

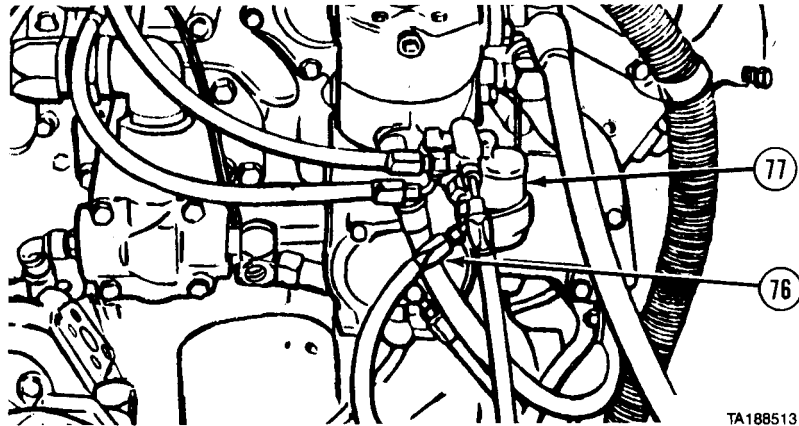

TA188513

(44) Connect STE/ICE connector (78).

(45) Connect oil cooler hose (79).

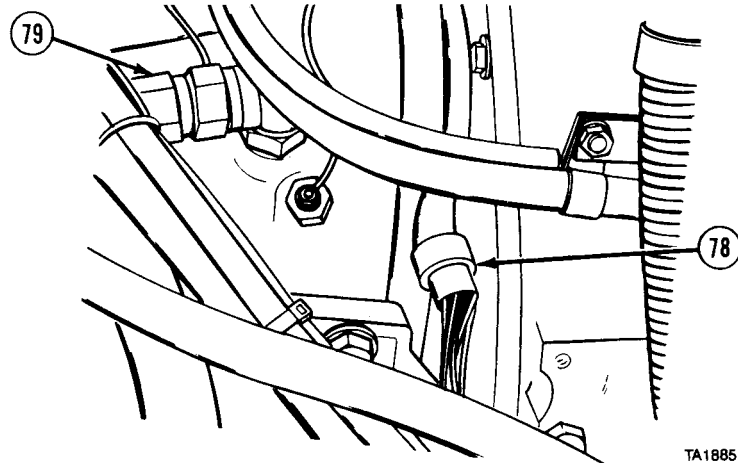

TA188514

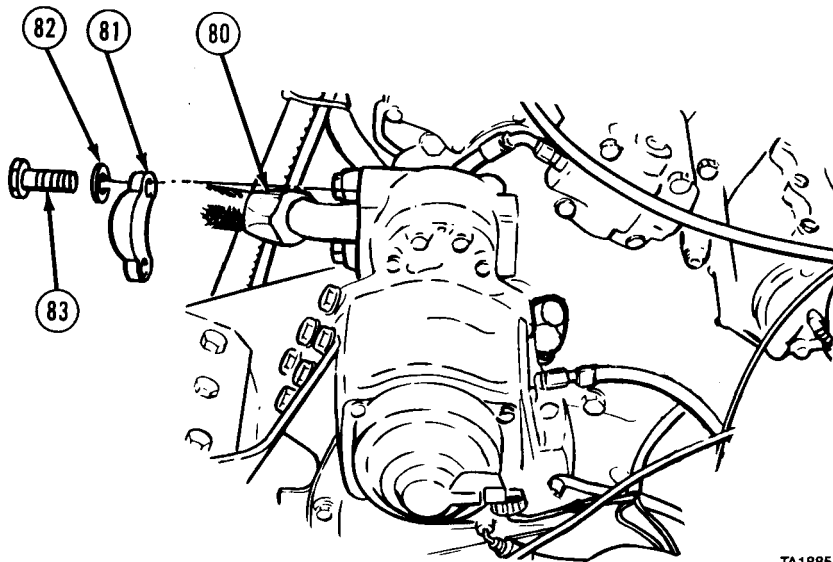

TA188515

NOTE

Go to step (50) when installing transmission on M984E1.

(46) Install hose (80) with two clamp halves (81), four lockwashers (82), and screws (83).

Transmission Maintenance Instructions (Cont)

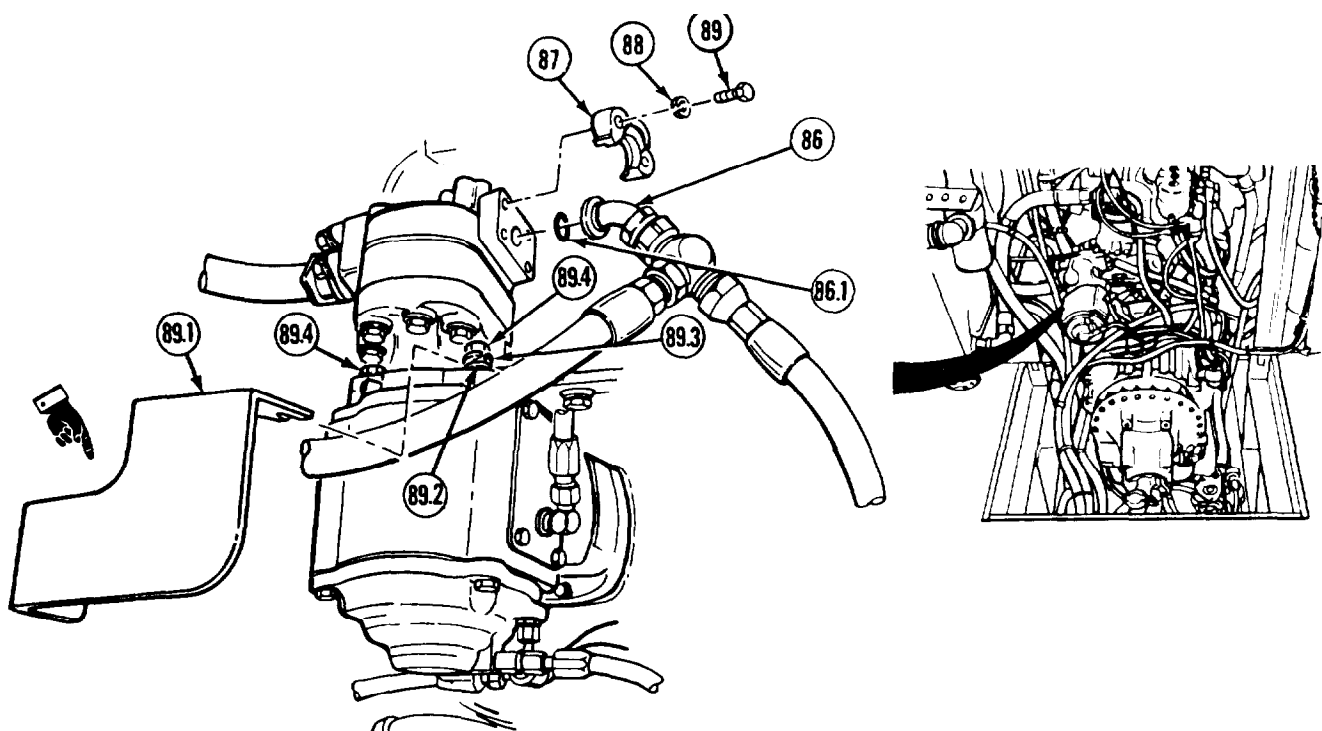

(47) Deleted.

(48) Install fitting (86), preformed packing (86.1), two clamp halves (87), four lockwashers (88), and screws (89).

NOTE

- Trucks with guard, perform step (48.1). Trucks without guard, proceed to step (50).
- Ensure guard is fully seated under flat washers.

(48.1) Install guard (89.1) under two flat washers (89.2) with two lockwashers (89.3) and screws (89.4).

(49) Deleted:

NOTE

Do steps (50) through (59) for M984E1.

- (50) Connect hose (92) to fitting (93) on heavy-duty winch manifold valve (94).
- (51) Connect two hoses (95) to fittings (96) on heavy-duty winch manifold valve (94).
- (52) Connect two hoses (97) to fittings (98) on heavy-duty winch manifold valve (94).
- (53) Connect hose (99) to fitting (100).
- (54) Remove valve (101).
- (55) Connect hose (102) to fitting (103) on heavy-duty winch manifold valve (94).
- (56) Install valve (101).

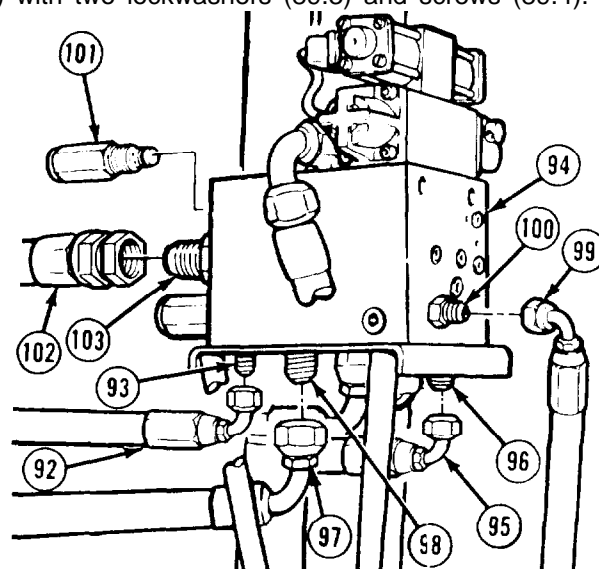

Transmission Maintenance Instructions (Cont)

7-4. TRANSMISSION REMOVAL/INSTALLATION (CONT).

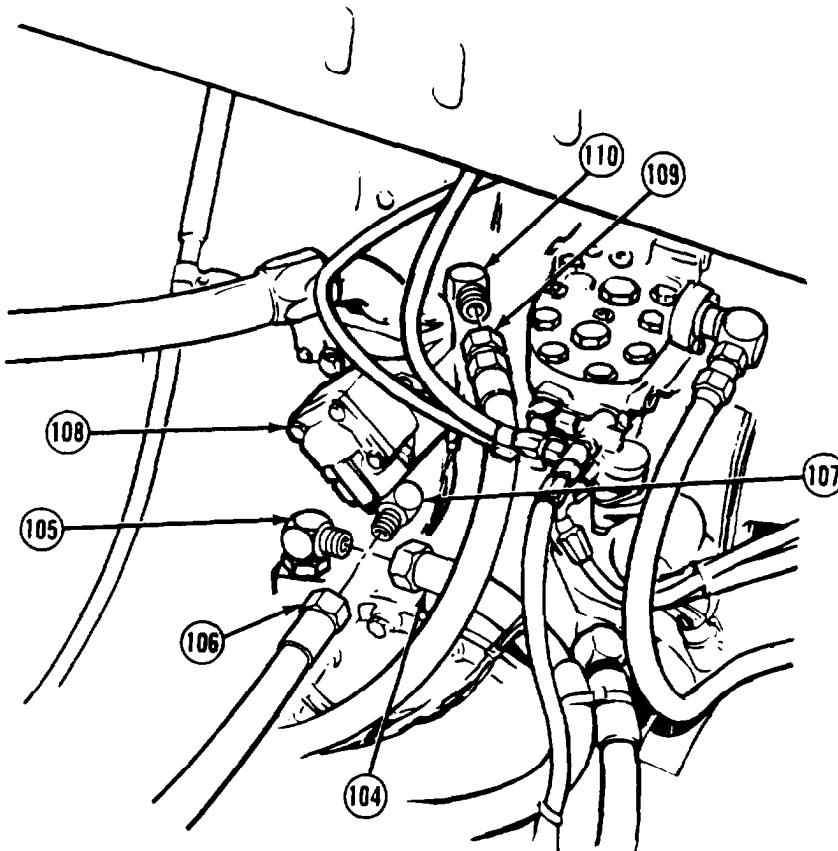

TA476446

- (57) Connect hose (104) to fitting (105).
- (58) Connect hose (106) to fitting (107) on pump (108).
- (59) Connect hose (109) to fitting (110).

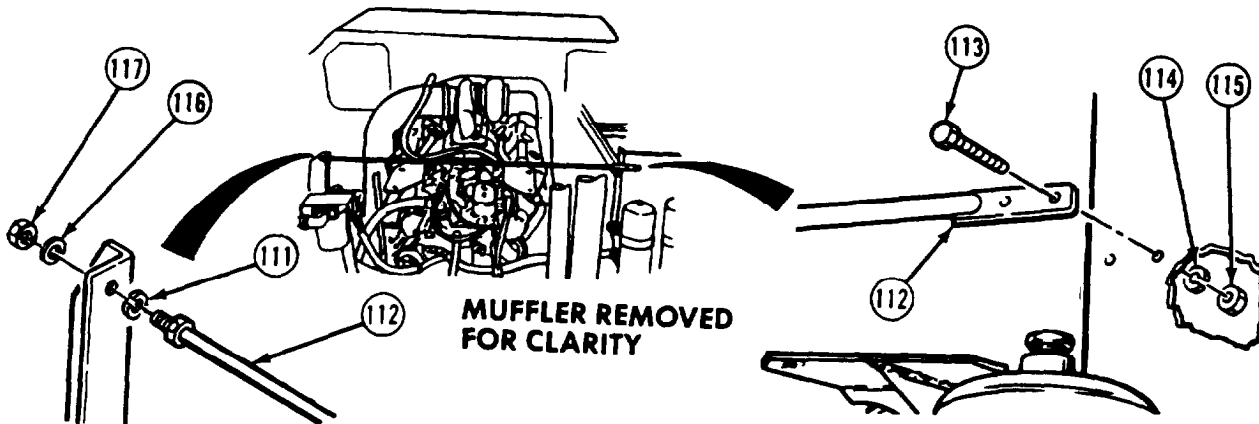

TA100517

- (60) Install lockwasher (111) on cross brace (112).
- (61) Install one end of cross brace (112) with two screws (113), lockwashers (114), and nuts (115).
- (62) Install lockwasher (116) and nut (117).

Transmission Maintenance Instructions (Cont)

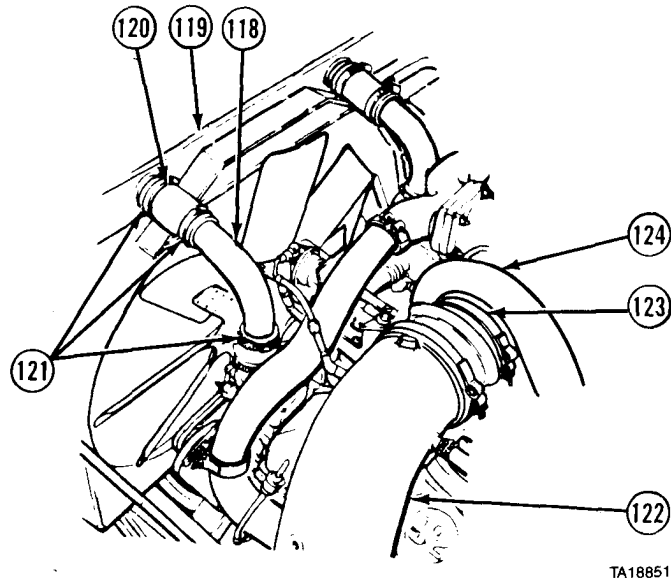
**NOTE**

Repeat steps (63) through (65) for right side coolant tube.

- (63) Turn coolant tube (118) towards radiator (119).
- (64) Install radiator hose (120).
- (65) Tighten three clamps (121).
- (66) Attach intake pipe (122) and tighten clamp (123) to turbocharger (124).

c. Follow-on Maintenance.

- (1) Fill radiator (TM 9-2320-279-20).
- (2) Fill and check transmission fluid level (LO 9-2320-279-12).
- (3) Fill hydraulic reservoir (TM 9-2320-279-20).
- (4) Install lift bracket assemblies (para 13-6).
- (5) Install right and left rear splash guards (TM 9-2320-279-20).
- (6) Install cargo body (M984) (para 15-16).
- (7) Install rear decking (M983 without crane) (TM 9-2320-279-20).
- (8) Install 30 KW generator (M983) (TM 9-2320-279-20).
- (9) Install fuel can stowage box (M978) (TM 9-2320-279-20).
- (10) Install cargo body floor panel (M977, M985) (para 15-9).
- (11) Install cargo body front panel (M977, M985) (TM 9-2320-279-20).
- (12) Install engine cover (TM 9-2320-279-20).
- (13) Install engine side panels (TM 9-2320-279-10).
- (14) Stow spare tire (TM 9-2320-279-10).
- (15) Connect batteries (TM 9-2320-279-20).
- (16) Start engine, build up pressure, and check operation of transmission (TM 9-2320-279-10).
- (17) Shut off engine (TM 9-2320-279-10).
- (18) Check for leaks (TM 9-2320-279-10).

END OF TASK

Transmission Maintenance Instructions (Cont)

7-5. TRANSMISSION INSTALLATION/REMOVAL FROM TRANSMISSION STAND.

This task covers:

- a. Installation of Transmission On Stand
- b. Removal of Transmission From Stand
- c. Follow-on Maintenance

INITIAL SETUP

<i>Models</i>	<i>Equipment Condition</i>	
All	<i>TM or Para</i>	<i>Condition Description</i>
<i>Test Equipment</i>	Para 7-4	Transmission removed.
None	TM 9-2320-279-20	Power takeoff (PTO) solenoid removed.
<i>Special Tools</i>	TM 9-2320-279-20	Transmission lockup solenoid removed.
Engine stand J6837C or J29109	TM 9-2320-279-20	Power takeoff (PTO) removed.
Transmission holding fixture J24310		
<i>Supplies</i>	<i>Special Environmental Conditions</i>	
None	None	
<i>Personnel Required</i>	<i>General Safety Instructions</i>	
MOS 63W, Wheel vehicle repairer (2)	None	
<i>References</i>	<i>Level of Maintenance</i>	
None	General Support	

a. Installation of Transmission On Stand.

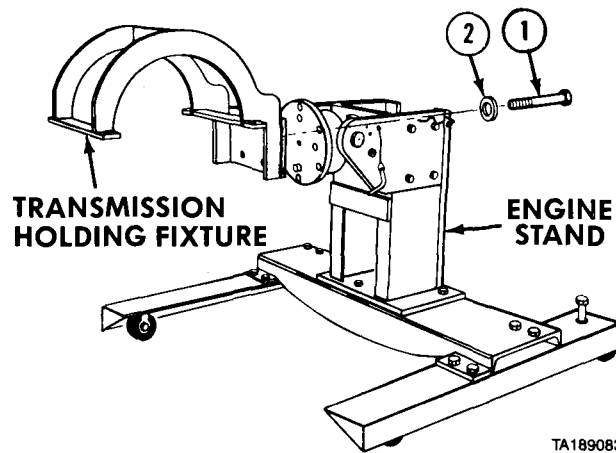

(1) Install transmission holding fixture on engine stand with four screws (1) and washers (2).

Transmission Maintenance Instructions (Cont)

7-5. TRANSMISSION INSTALLATION/REMOVAL FROM TRANSMISSION STAND (CONT).

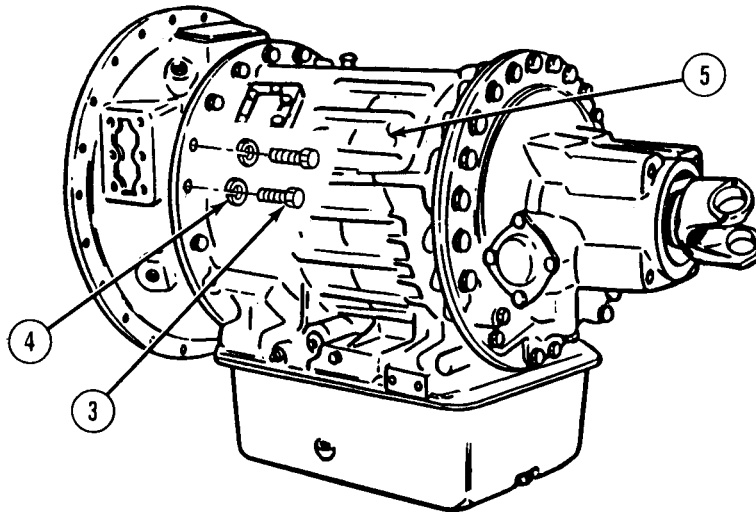

TA189084

- (2) Remove four screws (3) and lockwashers (4) from transmission (5).
- (3) Install suitable lifting device on transmission (5).

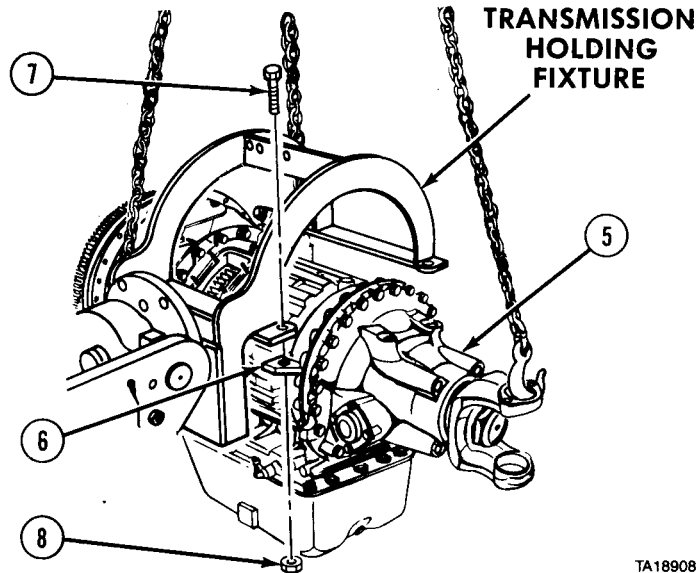

TA189085

- (4) Soldier A places transmission holding fixture over transmission (5) while Soldier B supports transmission with suitable lifting device.
- (5) Soldier A installs transmission holding fixture on four transmission mounting surfaces (6) with four screws (7) and locknuts (8).
- (6) Remove lifting device from transmission (5).

Transmission Maintenance Instructions (Cont)

b. Removal of Transmission From Stand.

- (1) Install suitable lifting device on transmission (1).
- (2) Soldier A removes four screws (2) and locknuts (3) while Soldier B supports transmission (1) with suitable lifting device.
- (3) Soldier A guides transmission (1) while Soldier B operates lifting device.
- (4) Remove lifting device from transmission (1).

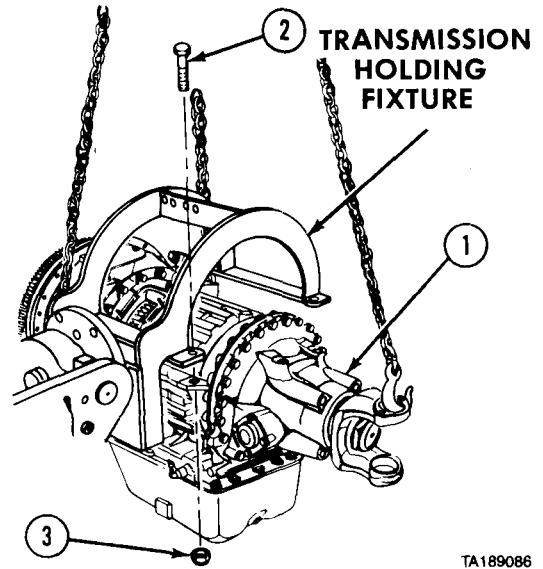

- (5) Install four screws (4) and lockwashers (5) on transmission (1). Tighten screws to 67 to 80 lb-ft (91 to 108 N·m).

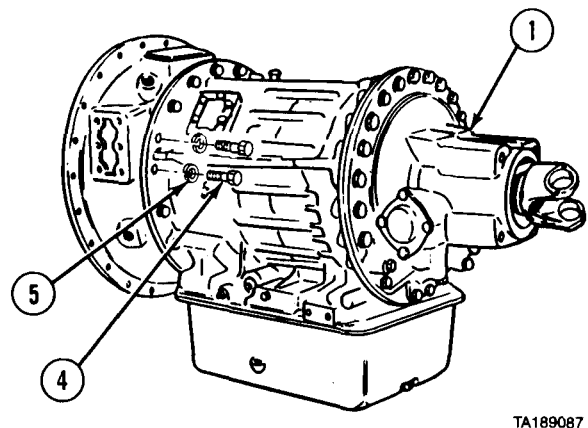

- (6) Remove four screws (6), washers (7), and transmission holding fixture from engine stand.

c. Follow-on Maintenance.

- (1) Install power takeoff (PTO) solenoid (TM 9-2320-279-20).
- (2) Install transmission lockup solenoid (TM 9-2320-279-20).
- (3) Install power takeoff (PTO) (TM 9-2320-279-20).
- (4) Install transmission (para 7-4).

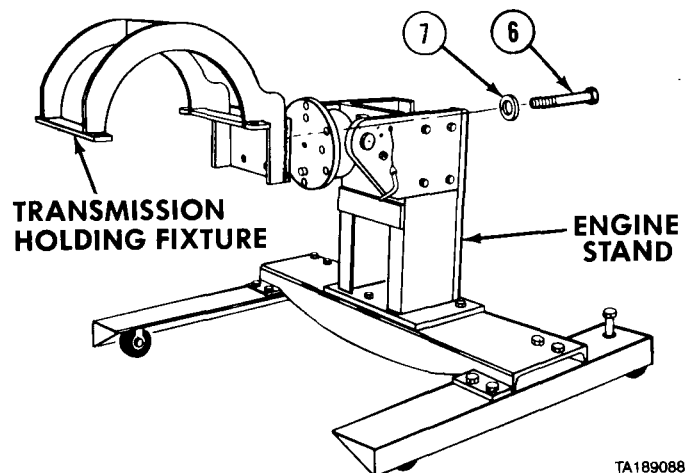

END OF TASK

Transmission Maintenance Instructions (Cont)

7-6. FLYWHEEL ASSEMBLY REMOVAL/REPAIR/INSTALLATION.

This task covers:

- | | |
|------------------------|--------------------------|
| a. Removal | d. Assembly |
| b. Disassembly | e. Installation |
| c. Cleaning/Inspection | f. Follow-on Maintenance |

INITIAL SETUP

Models

All

Test Equipment

None

Special Tools

Flywheel lifting bracket J24365

Supplies

Oil, lubricating, Item 46, Appendix C
Solvent, dry cleaning, Item 57, Appendix C

Personnel Required

MOS 63W, Wheel vehicle repairer (2)

References

None

Equipment Condition

<i>TM or Para</i>	<i>Condition Description</i>
Para 7-4	Transmission removed.

Special Environmental Conditions

None

General Safety Instructions

None

Level of Maintenance

Direct Support

a. Removal.

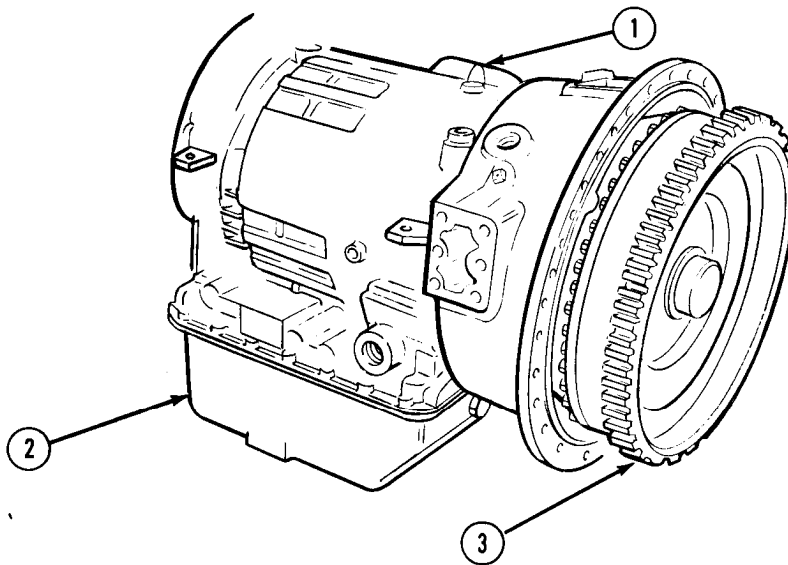

TA188862

(1) Position transmission (1) on blocks so oil pan (2) is at bottom.

(2) Set drain pan under flywheel (3) to catch draining oil.

Transmission Maintenance Instructions (Cont)

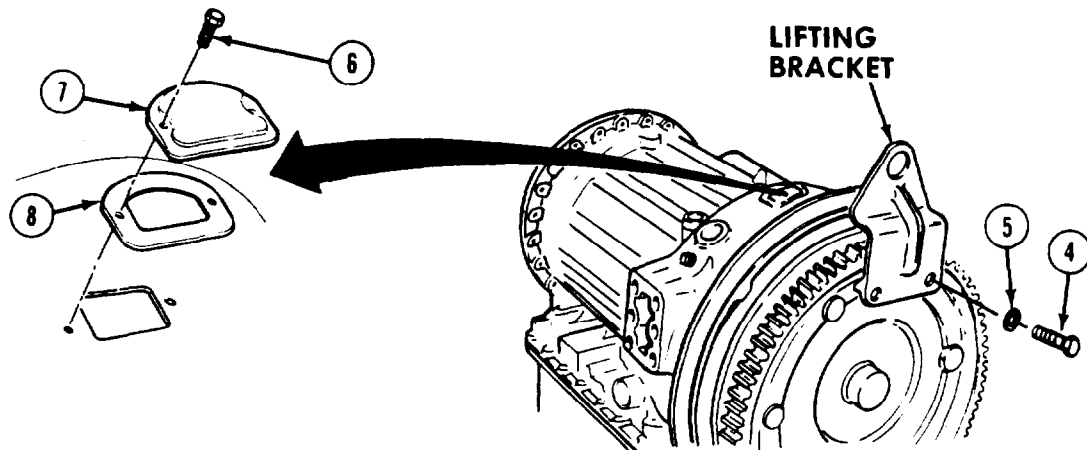

TA188863

- (3) Align and install lifting bracket with two screws (4) and washers (5).
- (4) Remove two screws (6) from access cover (7).
- (5) Remove access cover (7) and gasket (8).

NOTE

Use flywheel lifting bracket to turn flywheel for access to screws inside converter housing.

- (6) Remove 29 of 30 screws (9) and washers (10). Leave one screw in place behind lifting bracket.

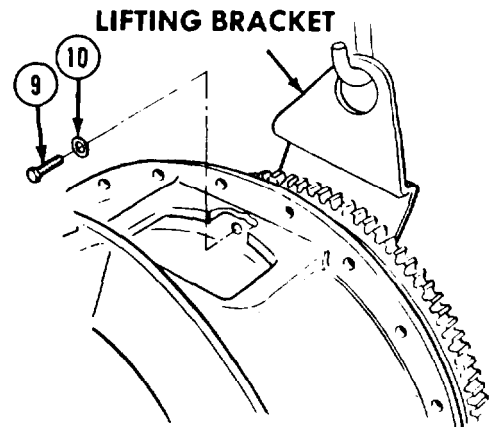

TA188864

- (7) Install lifting device to lifting bracket.
- (8) Raise lifting device until it supports weight of flywheel (3).

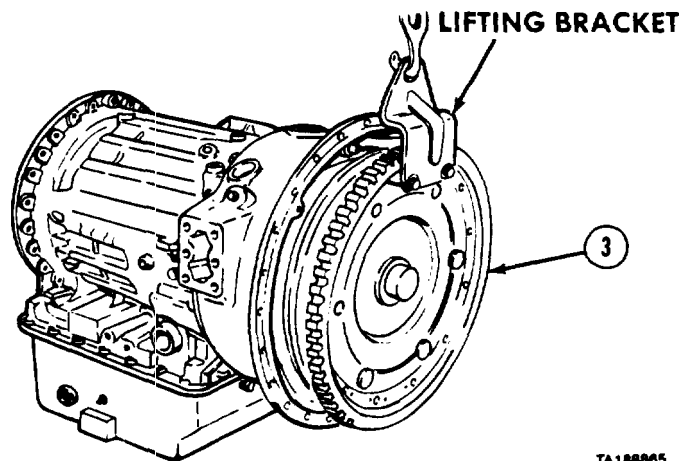

TA188865

Transmission Maintenance Instructions (Cont)

7-6. FLYWHEEL ASSEMBLY REMOVAL/REPAIR/INSTALLATION (CONT).

- (9) Remove the remaining screw (9) and washer (10) from flywheel (3).

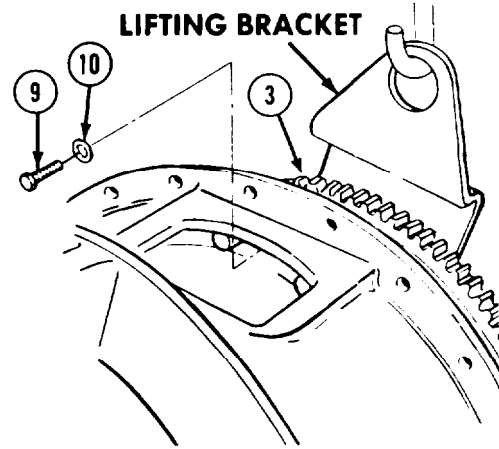

CAUTION

When flywheel is removed from converter housing, torque converter turbine may come off with flywheel, stay with converter housing, or be in a position to fall. Take care to prevent torque converter turbine from falling and becoming damaged.

- (10) Soldier A removes flywheel (3) with torque converter turbine (11) from converter pump (12) while Soldier B operates lifting device.
- (11) Soldier A moves flywheel (3) with torque converter turbine (11) to work surface while Soldier B operates lifting device. Soldier B removes lifting device.

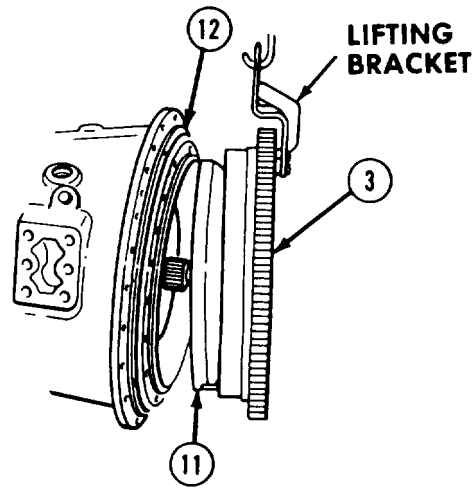

- (12) Remove converter seal ring (13) and turbine shaft seal ring (14).

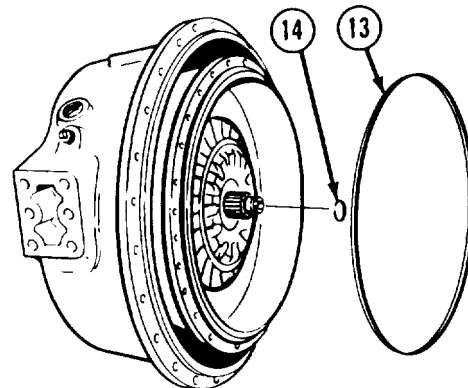

Transmission Maintenance Instructions (Cont)

- (13) Remove two screws (4) and washers (5).
- (14) Remove lifting bracket from flywheel (3).

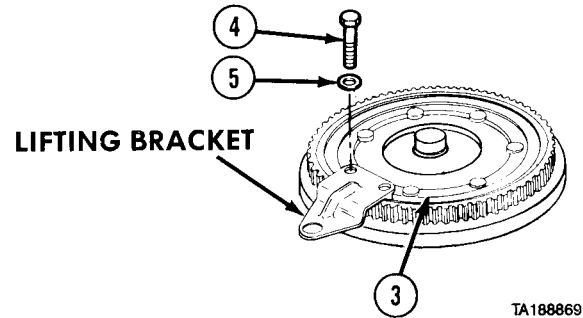

b. Disassembly.

- (1) Set flywheel (1) on work surface with torque converter turbine (2) up.

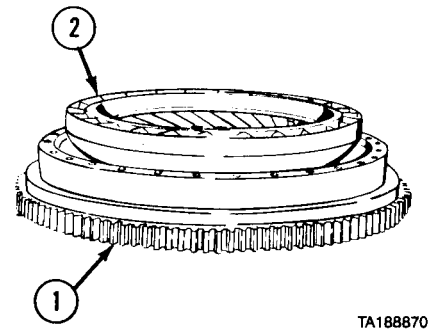

CAUTION

Torque converter turbine must be evenly pried up and off flywheel. Use shop towels at two pry points to prevent scoring or other damage to torque converter turbine or flywheel.

- (2) Remove torque converter turbine (2) from flywheel (1).

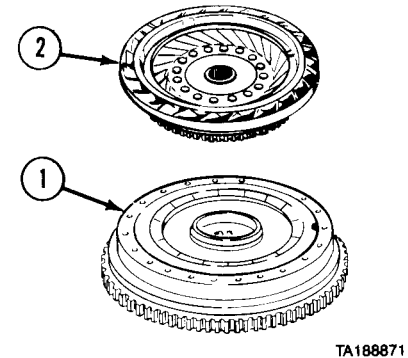

- (3) Remove backplate (3) from flywheel (1).

NOTE

Some transmissions will have two keys.

- (4) Remove key (4).

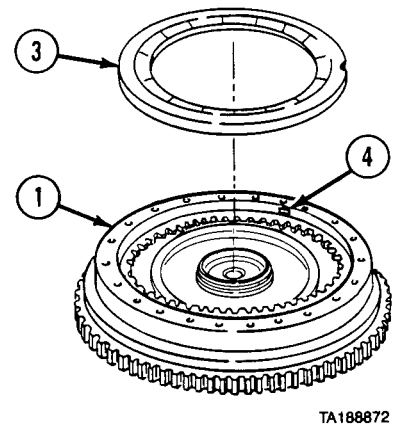

Transmission Maintenance Instructions (Cont)

7-6. FLYWHEEL ASSEMBLY REMOVAL/REPAIR/INSTALLATION (CONT).

(5) Remove lockup clutch plate (5).

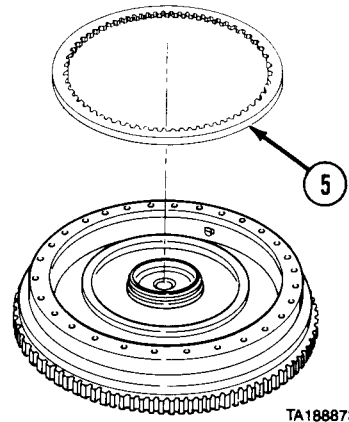

- (6) Turn flywheel (1) over and support on wooden blocks.
- (7) Lift flywheel (1) 1 ft (30.5 cm) and drop flywheel to free piston (6).
- (8) Remove piston (6).

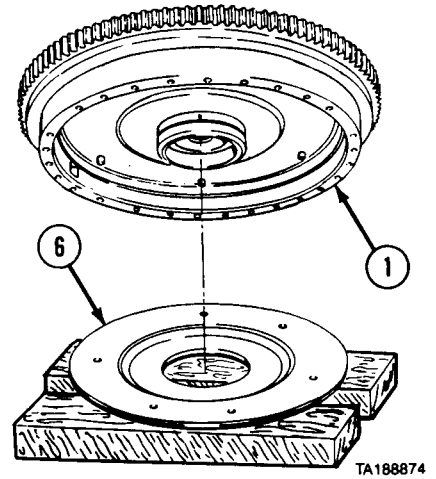

(9) Remove seal ring (7) from outer groove in piston (6).

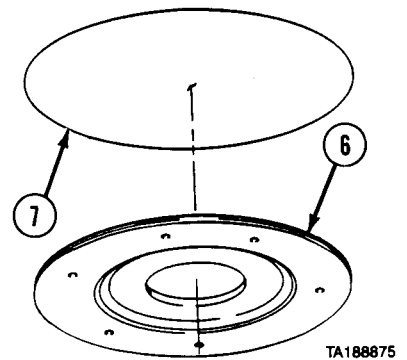

Transmission Maintenance Instructions (Cont)

(10) Remove seal ring (8) from outer groove in hub (9).

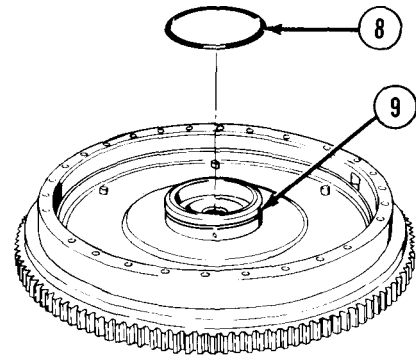

TA188876

(11) Set torque converter turbine (2) on work surface with bearing shaft (10) facing up.

(12) Remove bearing (11) from bearing shaft (10).

c. Cleaning/Inspection.

WARNING

Adhesives, solvents, and sealing compounds can burn easily, can give off harmful vapors, and are harmful to skin and clothing. To avoid injury or death, keep away from open fire and use in well-ventilated area. If adhesive, solvent, or sealing compound gets on skin or clothing, wash immediately with soap and water.

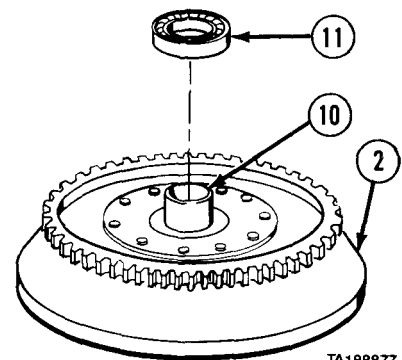

TA188877

(1) Clean all metallic parts with dry cleaning solvent.

WARNING

Compressed air used for cleaning purposes will not exceed 30 psi (207 kPa). Use only with effective chip guarding and personal protective equipment, goggles, shield, and gloves.

(2) Dry all parts, except bearings, with compressed air.

(3) Inspect all parts for damage.

(4) Replace damaged parts.

(5) Measure thickness of lockup clutch plate (1). Replace if less than 0.19-in. (4.8 mm) thick.

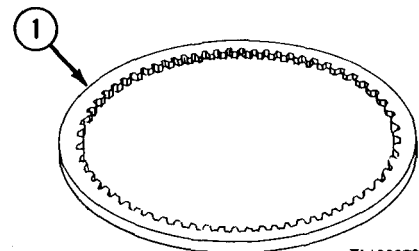

TA188878

Transmission Maintenance Instructions (Cont)

7-6. FLYWHEEL ASSEMBLY REMOVAL/REPAIR/INSTALLATION (CONT).

(6) Place straight edge on backplate (2).

CAUTION

If backplate is to be replaced on transmission prior to Serial No. 83229, a new two keyed flywheel must be used.

(7) If feeler gage larger than 0.010 in. (0.25 mm) will fit under straight edge, replace backplate (2).

(8) Place straight edge on piston (3).

(9) If feeler gage larger than 0.010 in. (0.25 mm) will fit under straight edge, replace piston (3).

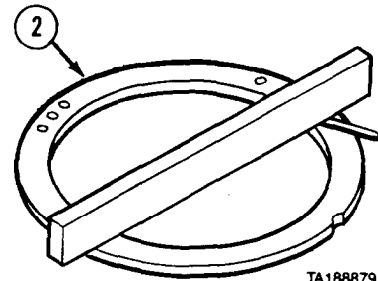

TA188879

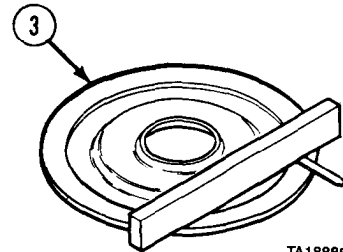

TA188880

d. Assembly.

NOTE

On transmission prior to Serial No. 83229 the old style flywheel and backplate were used. If either flywheel or backplate are to be replaced, they must be replaced with the new two keyed flywheel and backplate.

- (1) Coat bearing shaft (1) and bearing (2) with lubricating oil.
- (2) Seat bearing (2) on bearing shaft (1) with identification number up.
- (3) Press bearing (2) on bearing shaft (1).
- (4) Coat outside of hub (3) with lubricating oil.
- (5) Apply lubricating oil to seal ring (4) and install seal ring in outer groove on hub (3).

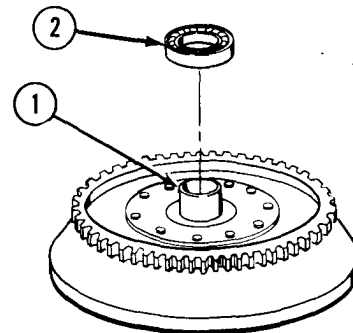

TA188881

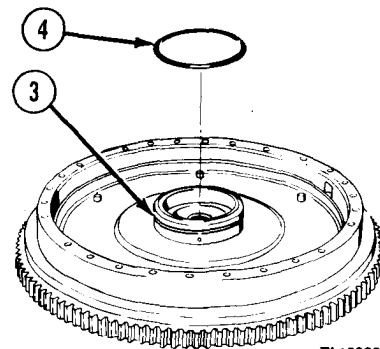

TA188882

Transmission Maintenance Instructions (Cont)

- (6) Apply lubricating oil to outer groove of piston (5).
- (7) Apply lubricating oil to seal ring (6) and install.

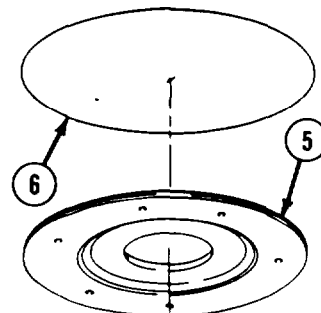

- (8) Apply lubricating oil to inner hub (7) of piston (5) and to piston seal surface (8) of flywheel (9).
- (9) Aline six holes (10) with six pins (11).
- (10) Install piston (5) on hub (3). Make sure piston is firmly seated on pins (11).

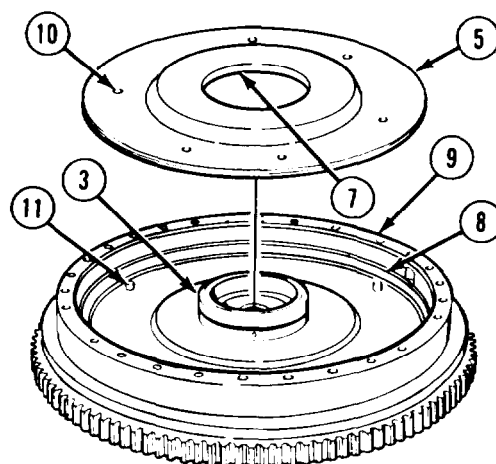

NOTE

Some transmissions will have two keys.

- (11) Install key (12) in slot (13).

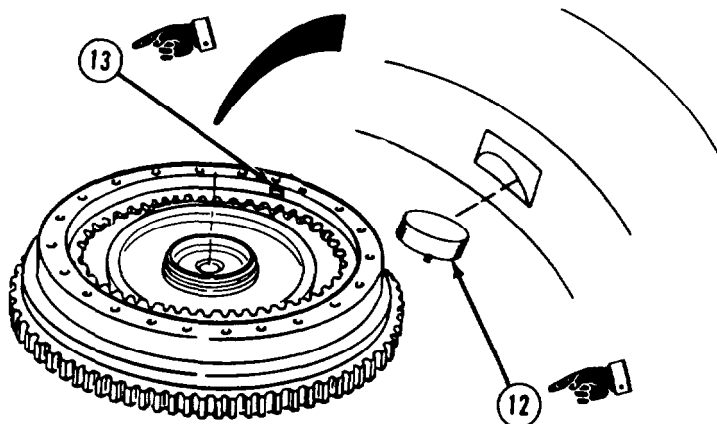

Transmission Maintenance Instructions (Cont)

7-6. FLYWHEEL ASSEMBLY REMOVAL/REPAIR/INSTALLATION (CONT).

- (12) Soak lockup clutch plate (14) in lubricating oil for 3 minutes and install.

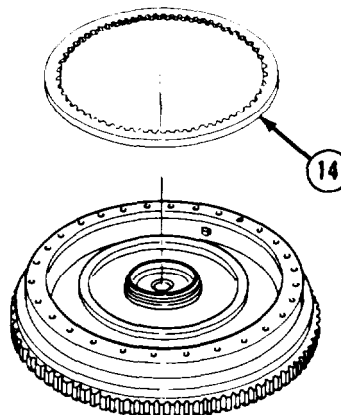

NOTE

On transmission prior to Serial No. 83229, the old style flywheel and backplate were used. If either flywheel or backplate are to be replaced, they must be replaced with the new two keyed flywheel and backplate.

- (13) Aline notch (15) with key (12) and install backplate (16) flat side first in flywheel (9).

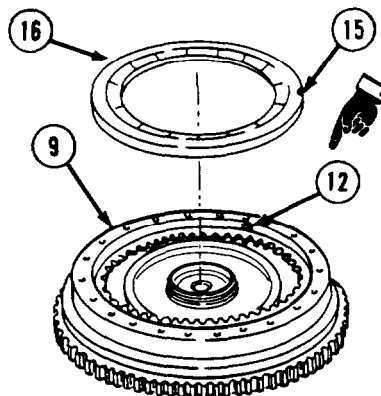

NOTE

Gear on torque converter turbine must be lined up with teeth of lockup clutch plate before installation.

- (14) Install torque converter turbine (17) on flywheel (9).

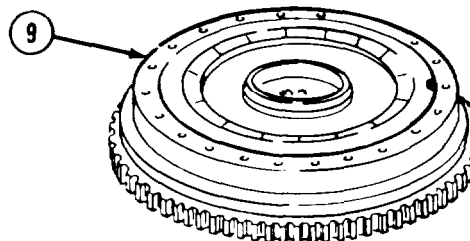
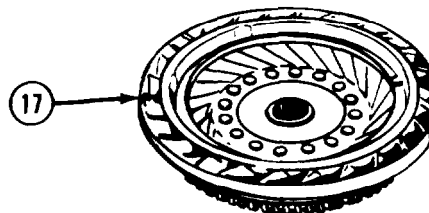

Transmission Maintenance Instructions (Cont)

e. Installation.

- (1) Install lifting bracket with two screws (1) and washers (2).

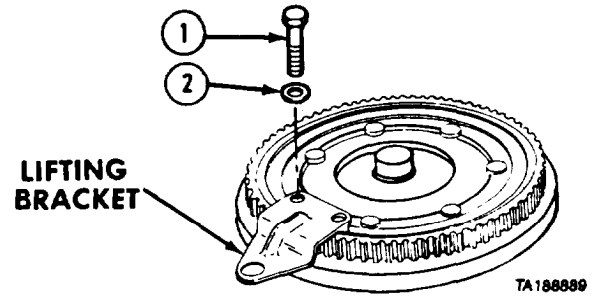

- (2) Coat turbine shaft seal ring (3) and converter seal ring (4) with lubricating oil.
- (3) Install turbine shaft seal ring (3) in groove and snap ends together.
- (4) Install converter seal ring (4) on torque converter pump (5).
- (5) Coat torque converter thrust pads (6) with lubricating oil.

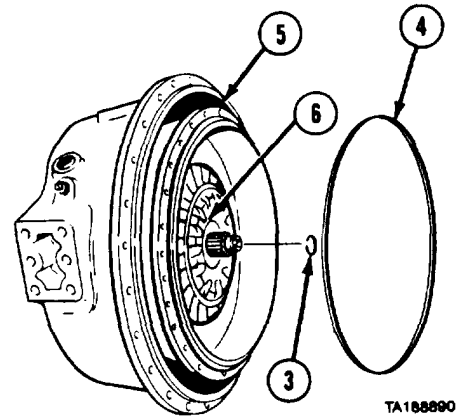

- (6) Soldier A aligns and installs flywheel (7) so flywheel fits flush against torque converter pump (5) while Soldier B operates lifting device.

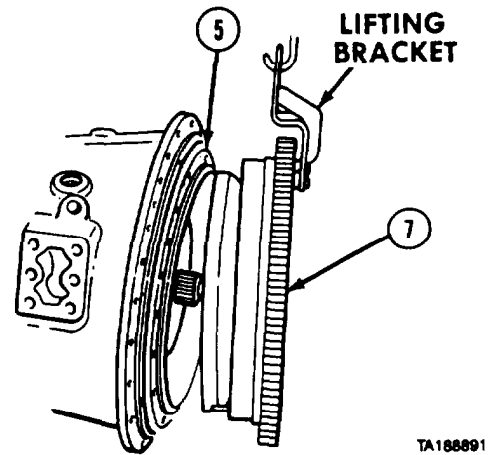

Transmission Maintenance Instructions (Cont)

7-6. FLYWHEEL ASSEMBLY REMOVAL/REPAIR/INSTALLATION (CONT).

- (7) Install one screw (8) and washer (9) through hole (10) in flywheel (7). Tighten screw until snug.
- (8) Remove lifting device from lifting bracket.

NOTE

Lifting bracket is used to turn flywheel for access to screw holes inside converter housing.

- (9) Install 29 screws (8) and washers (9) through holes (10) in flywheel (7). Tighten screws until snug.

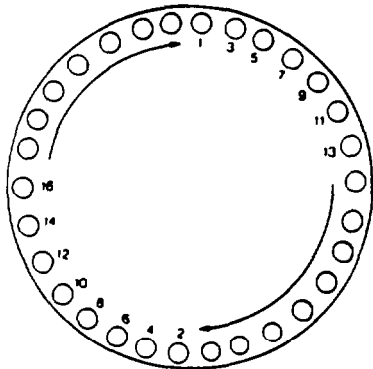
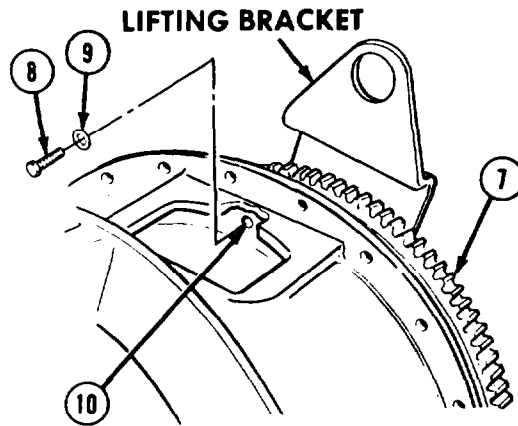

TIGHTEN SCREWS IN ORDER SHOWN

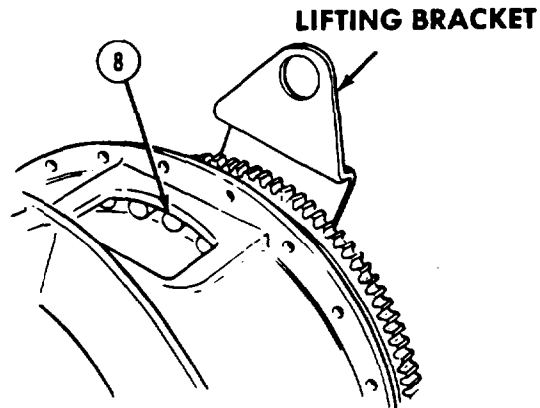

- (10) Tighten 30 screws (8) to 41 to 49 lb-ft (56 to 66 N•m).

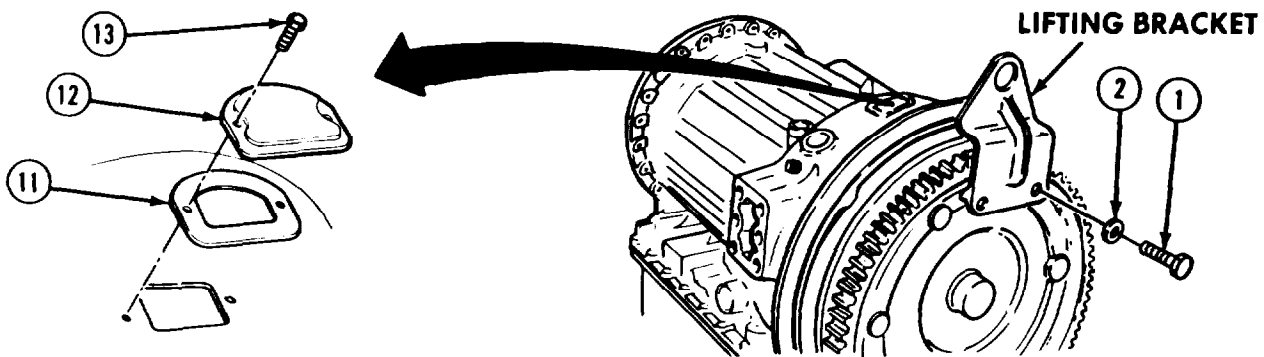

- (11) Remove two screws (1) and washers (2).
- (12) Remove lifting bracket.
- (13) Install gasket (11) and access cover (12).
- (14) Install two screws (13).
- (15) Tighten two screws (13) to 26 to 32 lb-ft (35 to 43 N•m).

f. **Follow-on Maintenance.** Remove transmission from transmission stand (para 7-5).

END OF TASK

Transmission Maintenance Instructions (Cont)

7-7. TORQUE CONVERTER STATOR REMOVAL/REPAIR/INSTALLATION.

This task covers:

- | | |
|------------------------|--------------------------|
| a. Removal | d. Assembly |
| b. Disassembly | e. Installation |
| c. Cleaning/Inspection | f. Follow-on Maintenance |

INITIAL SETUP

Models
All

Test Equipment
None

Special Tools
Stator roller holder J24218-2

Supplies
Oil, lubricating, Item 46, Appendix C
Solvent, drycleaning, Item 57, Appendix C

Personnel Required
MOS 63W, Wheel vehicle repairer

References
None

Equipment Conditions
TM or Para
Para 7-5
Condition Description
Transmission installed on transmission stand.
Flywheel assembly removed.

Special Environmental Conditions
None

General Safety Instructions
None

Level of Maintenance
General Support

NOTE

- Twist stator counterclockwise and away from torque converter pump when removing stator from shaft.
- Bearings and springs may fall out when stator is removed.

a. **Removal.** Remove stator (1) from shaft (2).

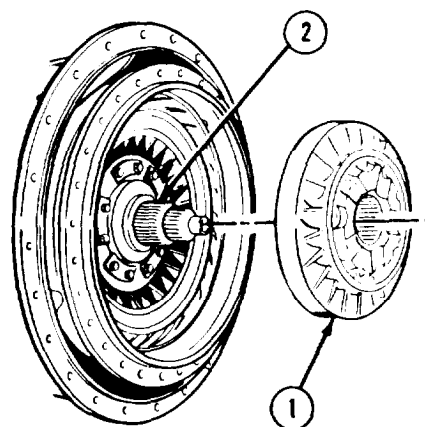

b. **Disassembly.**

- (1) Hold rim of stator (1) on work surface.
- (2) Turning roller race (2) clockwise, slowly remove roller race from stator (1).
- (3) Remove roller bearing (3) and thrust bearing race (4) from stator (1).

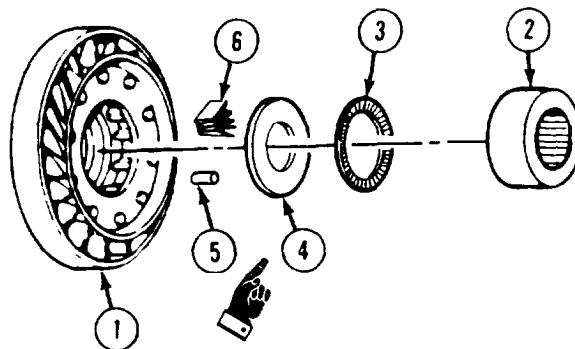

NOTE

Note orientation of springs prior to removal from stator.

- (4) Remove 10 rollers (5) and 10 roller springs (6) from stator (1).

Transmission Maintenance Instructions (Cont)

7-7. TORQUE CONVERTER STATOR REMOVAL/REPAIR/INSTALLATION (CONT).

C. Cleaning/Inspection.

WARNING

Adhesives, solvents, and sealing compounds can burn easily, can give off harmful vapors, and are harmful to skin and clothing. To avoid injury or death, keep away from open fire and use in well-ventilated area. If adhesive, solvent, or sealing compound gets on skin or clothing, wash immediately with soap and water.

- (1) Clean all parts in drycleaning solvent.

WARNING

Compressed air used for cleaning purposes will not exceed 30 psi (207 kPa). Use only with effective chip guarding and personal protective equipment, goggles, shield, and gloves.

- (2) Use clean lint free cloth or compressed air to dry parts cleaned with drycleaning solvent.
- (3) Inspect parts for damage. Replace damaged parts.
- (4) Coat all parts with lubricating oil.

d. Assembly.

- (1) Position stator (1) on work surface, rear side upward.
- (2) Install thrust bearing race (2) in stator (1).

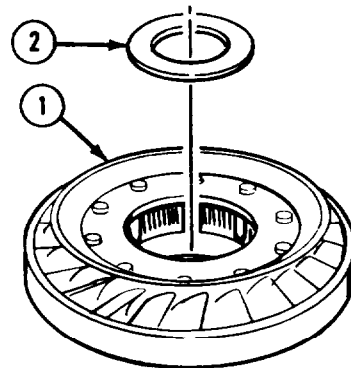

- (3) Install stator roller holder against thrust bearing race (2) so string of stator roller holder hangs out bottom of stator (1).

STATOR ROLLER HOLDER

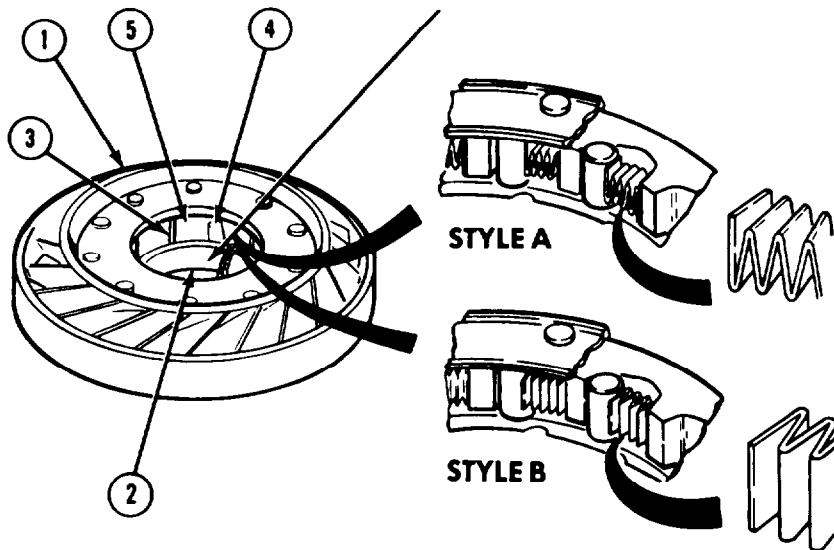

CAUTION

Roller springs must be installed as shown in illustration. On later models install the spring with bends against stator thrust washers (Style A). The ends of the spring can be up or down against the roller. Earlier models require the end of the spring to be against the roller with bends toward the freewheel roller race (Style B).

- (4) Install 10 roller springs (3) and rollers (4) in stator cam pockets (5).

Transmission Maintenance Instructions (Cont)

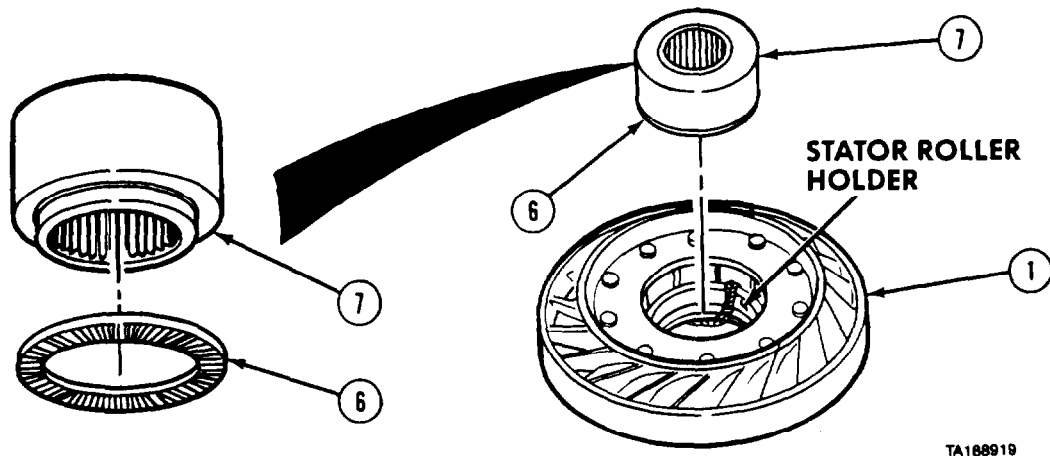

TA188919

- (5) Install roller bearing (6) on roller race (7).
- (6) Install roller race (7) in stator (1) until roller bearing (6) is near stator roller holder.
- (7) Remove stator roller holder by pulling on attached string.
- (8) Push roller race (7) inward while turning roller race clockwise until roller bearing (6) seats.
- (9) Position stator (1) with roller race (7) up.
- (10) Turn roller race (7) counterclockwise to lock in place.

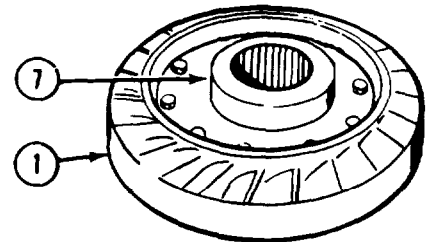

TA188917

e. Installation.

CAUTION

Keep outer face of stator down so bearings and springs will not fall out.

- (1) Hold stator (1) with thrust pads (2) away from transmission (3).

CAUTION

Stator must turn freely in clockwise direction and lock up in counterclockwise direction to operate properly and prevent damage to equipment.

- (2) Install stator (1) on shaft (4).

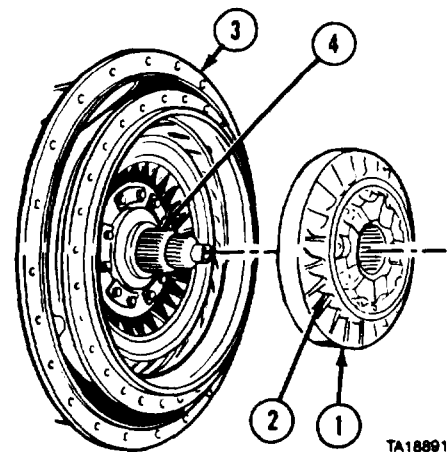

TA188916

- f. Follow-on Maintenance.** Install flywheel assembly (para 7-6).

END OF TASK

Transmission Maintenance Instructions (Cont)

7-8. TORQUE CONVERTER PUMP REMOVAL/REPAIR/INSTALLATION		
This task covers:		
a. Removal	d. Assembly	
b. Disassembly	e. Installation	
c. Cleaniing/Inspection	f. Follow-on Maintenance	
INITIAL SETUP		
<i>Models</i> All	<i>References</i> None	
<i>Test Equipment</i> None	<i>Equipment Condition</i> TM or Para Pat-a 7-7	<i>Condition Description</i> Torque converter stator removed from torque converter housing.
<i>Special Tools</i> Rear bearing installer J24447 Driver handle J24202-4	<i>Special Environmental Conditions</i> None	
<i>Supplies</i> Oil, lubricating, Item 46, Appendix C Solvent, drycleaning, Item 57, Appendix C	<i>General Safety Instructions</i> None	
<i>Personnel Required</i> MOS 63W. Wheel vehicle repairer	<i>Level of Maintenance</i> General Support	

a. Removal.

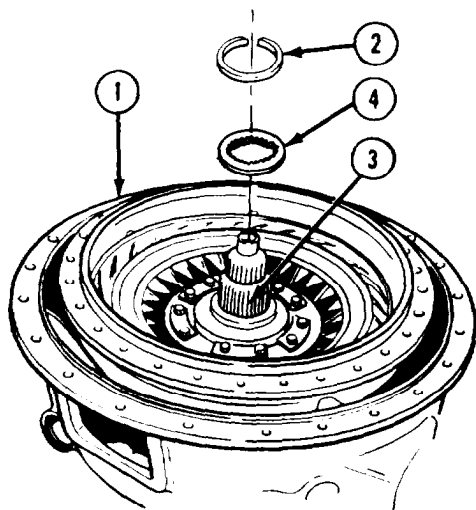

- (1) Turn transmission so torque converter housing (1) faces up.

CAUTION

Do not scrape the ground sleeve during removal.

- (2) Remove retaining ring (2) from ground sleeve (3).
- (3) Remove Spacer (4).

Transmission Maintenance Instructions (Cont)

- (4) Bend corners of two lockstrips (5) away from heads of two opposing screws (6).
- (5) Remove two screws (6) from lockstrips (5).

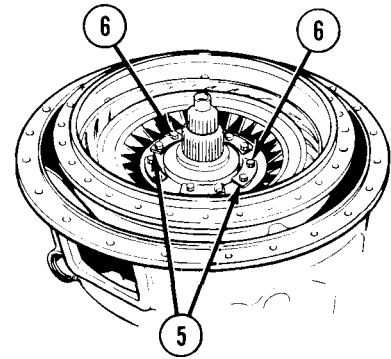

TA188847

- (6) Install puller (7).
- (7) Tighten puller (7) to separate pump (8) from ground sleeve (3).
- (8) Remove puller (7).
- (9) Remove pump (8) and set on work surface.

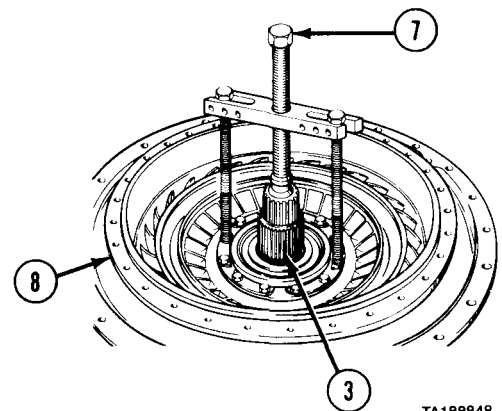

TA188848

b. Disassembly.

- (1) Bend corners of four lockstrips (1) away from heads of 10 screws (2).
- (2) Remove 10 screws (2) and six lockstrips (1).

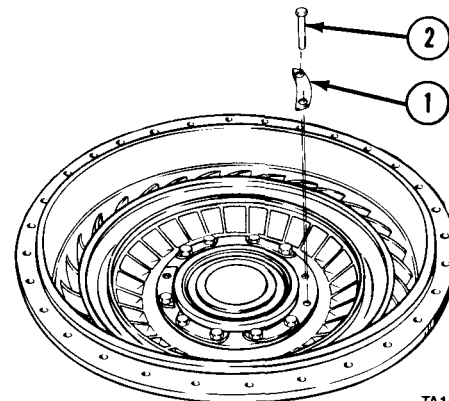

TA188849

Transmission Maintenance Instructions (Cont)

7-8. TORQUE CONVERTER PUMP REMOVAL/REPAIR/INSTALLATION (CONT).

(3) Remove bearing retainer (3) from pump (4).

NOTE

There are two kinds of converter pump hubs. Model A (6834741) uses a gasket between the hub and converter pump. Model B (23045371) has a groove on the mounting surface and uses a seal ring in place of the gasket.

- (4) Remove hub (5), gasket or seal ring (6), and seal ring (7).
- (5) Remove gasket or seal ring (6) and seal ring (7) from hub (5).
- (6) Remove outer race (8) and bearing (9).
- (7) Remove inner race (10).

c. Cleaning/Inspection.

WARNING

Adhesives, solvents, and sealing compounds can burn easily, can give off harmful vapors, and are harmful to skin and clothing. To avoid injury or death, keep away from open fire and use in well-ventilated area. If adhesive, solvent, or sealing compound gets on skin or clothing, wash immediately with soap and water.

- (1) Clean all metal parts with dry cleaning solvent.

WARNING

Compressed air used for cleaning purposes will not exceed 30 psi (207 kPa). Use only with effective chip guarding and personal protective equipment, goggles, shield, and gloves.

- (2) Dry all metal parts, except bearings, with compressed air.
- (3) Inspect all parts for damage.
- (4) Replace damaged parts.
- (5) Coat all parts with lubricating oil.

d. Assembly.

NOTE

There are two kinds of converter pump hubs. Model A (6834741) uses a gasket between the hub and converter pump. Model B (23045371) has a groove on the mounting surface and uses a seal ring in place of the gasket.

- (1) Apply lubricating oil to gasket or seal ring (1) and install on hub (2).

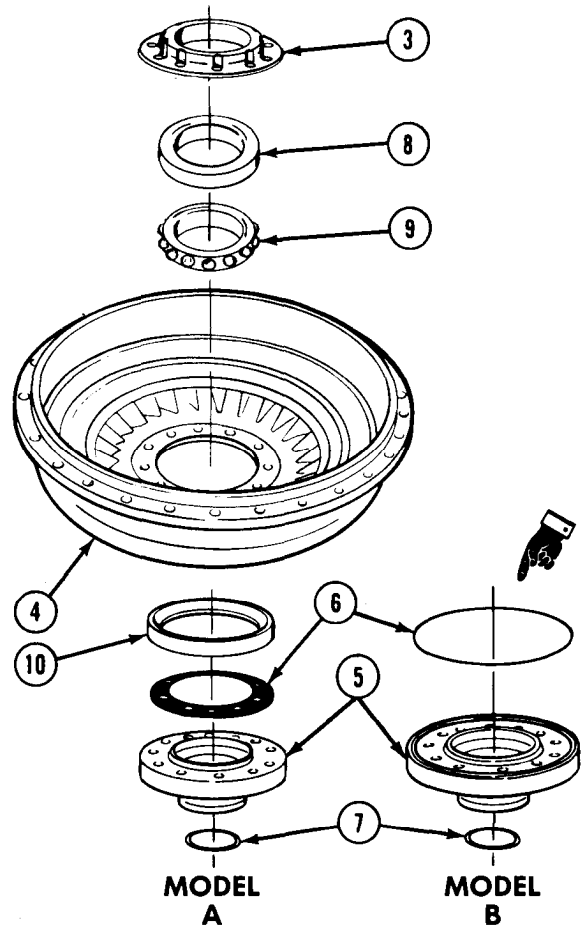

TA500301

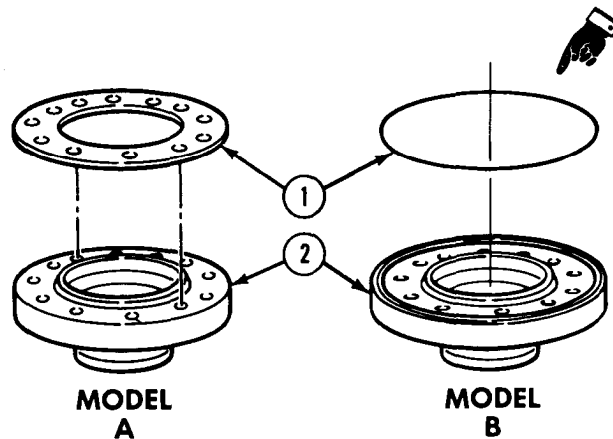

TA500302

Transmission Maintenance Instructions (Cont)

NOTE

Check that three parts of bearing have same serial number.

- (2) Install inner race (3) on hub (2).
- (3) Install pump (4) on hub (2).

CAUTION

Bearing must be kept clean during installation. Keep bearing wrapped until bearing is installed. Set bearing on clean, lint-free paper and never on dirty surface.

- (4) Install bearing (5) in inner race (3).
- (5) Install outer race (6) over bearing (5).
- (6) Position bearing retainer (7) shoulder side up on hub (2).

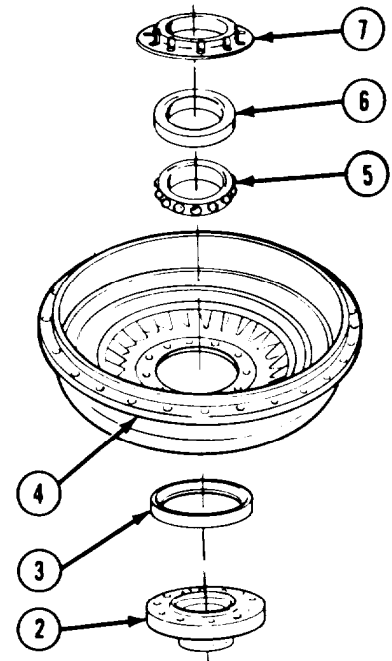

- (7) Install one screw (9) and lockstrip (8) at 12 o' clock position. Do not tighten bolt.
- (8) Install three more screws (9) and lockstrips (8) at 3, 6, and 9 o' clock positions.
- (9) Snug screws in sequence (12, 6, 3, and 9 o' clock).

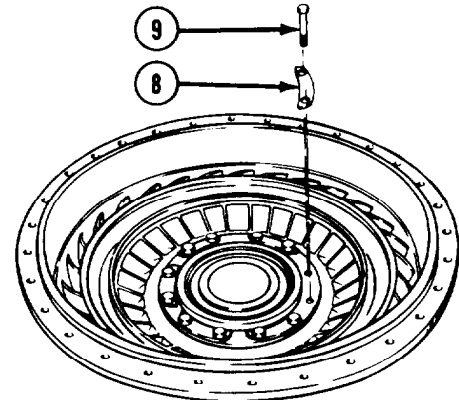

CAUTION

Failure to tighten screws using sequential tightening procedures may lead to premature bearing failure.

- (10) Tighten screws (9) to 33 to 40 lb-ft (45 to 54 N•m) in sequence (12, 6, 3, and 9 o' clock).
- (11) Install the remaining eight screws (9) and two lockstrips (8). Tighten screws (9) and lockstrips (8) to 33 to 40 lb-ft (45 to 54 N•m).
- (12) Bend corners of lockstrips (8) against head of screws (9).

e. Installation.

NOTE

Keep seal ring sealed in package until ready to use so seal ring does not change shape.

- (1) Roll seal ring (1) to one-half length and hold for at least 10 seconds.
- (2) Install seal ring (1) in groove (2).

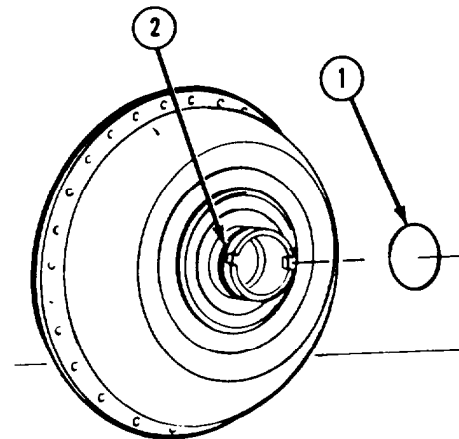

Transmission Maintenance Instructions (Cont)

7-8. TORQUE CONVERTER PUMP REMOVAL/REPAIR/INSTALLATION (CONT).

- (3) Install pump (3) in torque converter housing (4).

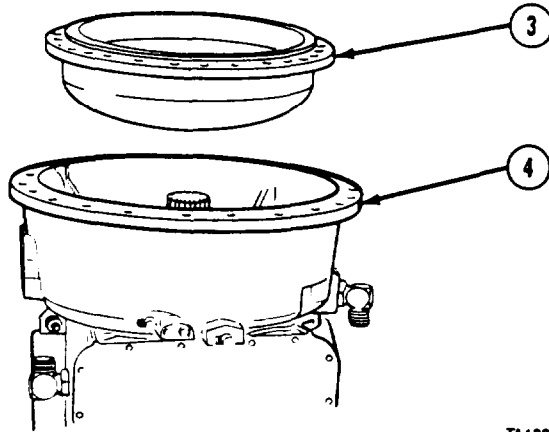

TA188855

- (4) Install bearing installer tool around ground sleeve (5) and on bearing (6).

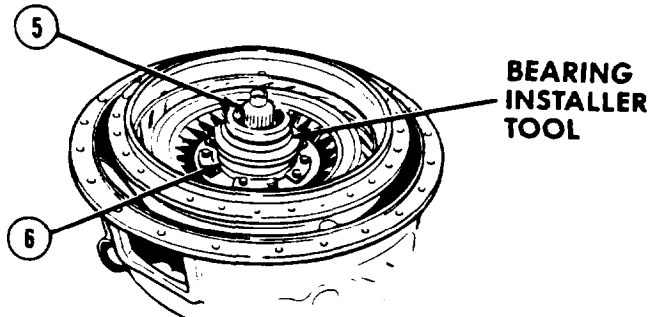

TA188856

- (5) Place bearing installer tool handle over bearing installer tool.
- (6) Drive bearing (6) down until seated.
- (7) Remove bearing installer tool.

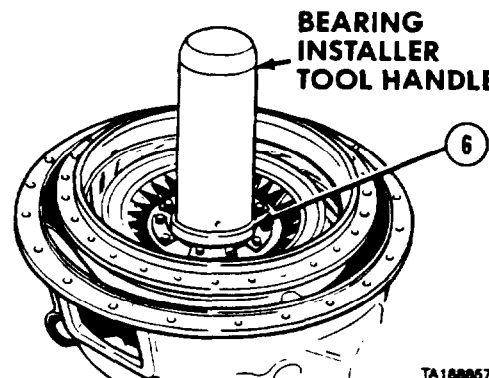

TA188857

Transmission Maintenance Instructions (Cont)

- (8) Install spacer (7) over ground sleeve (5) on pump (3).
- (9) Install retaining ring (8) on ground sleeve (5).
- (10) Coat pump hub (3) and hub area (9) with lubricating oil.

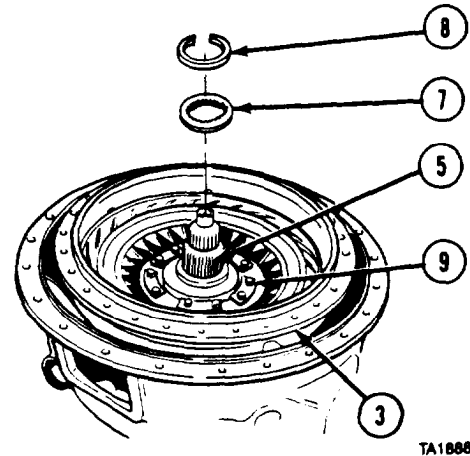

f. follow-on Maintenance. Install torque converter stator into torque converter housing (para 7-7).

END OF TASK

7-9. TORQUE CONVERTER HOUSING REMOVAL/REPAIR/INSTALLATION.	
This task covers:	
a. Removal	d. Assembly
b. Disassembly	e. Installation
c. Cleaning/Inspection	f. Follow-on Maintenance
INITIAL SETUP	
<i>Models</i>	<i>Personnel Required</i>
All	MOS 63W, Wheel vehicle repairer (2)
<i>Test Equipment</i>	<i>References</i>
None	None
<i>Special Tools</i>	<i>Equipment Condition</i>
Pitot tube guide screws (2) J6889-1	<i>TM or Para</i>
Front support needle bearing installer J24197	Para 7-8
<i>Fabricated Tools</i>	<i>Condition Description</i>
Lifting eyes, Item 1, Appendix B	Torque converter pump removed from torque converter housing.
<i>Supplies</i>	<i>Special Environmental Conditions</i>
Oil, lubricating, Item 46, Appendix C	None
Adhesive-sealant, silicone, Item 6, Appendix C	<i>General Safety Instructions</i>
Solvent, dry cleaning, Item 57, Appendix C	None
Tags, identification, Item 60, Appendix C	<i>Level of Maintenance</i>
	General Support

Transmission Maintenance Instructions (Cont)

7-9. TORQUE CONVERTER HOUSING REMOVAL/REPAIR/INSTALLATION (CONT).

a. Removal.

- (1) Remove two screws (1) and washers (2) from inside torque converter housing (3).
- (2) Remove seven screws (4) and lockwashers (5) from inside torque converter housing (3).

NOTE

Two screws and lockwashers were removed from torque converter housing during installation of holding fixtures. Seven screws and lockwashers remain to hold torque converter housing on transmission housing.

- (3) Remove seven screws (6) and lockwashers (7) holding torque converter housing (3) to transmission housing (8).
- (4) Install two lifting eyes on torque converter housing (3).
- (5) Install lifting device to lifting eyes.

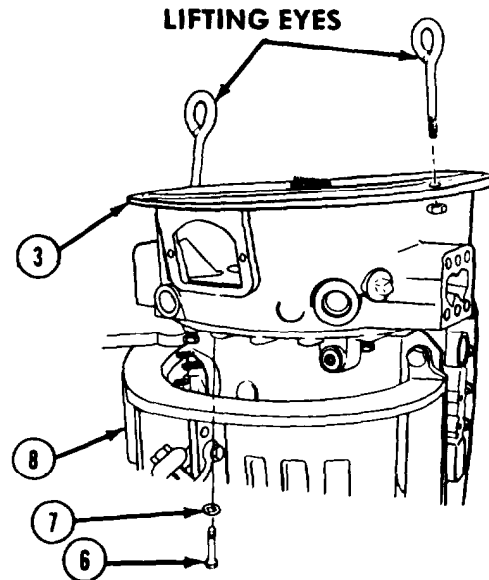

- (6) Soldier A removes torque converter housing (3) while Soldier B operates lifting device.
- (7) Remove bearing race (9), roller bearing (10), and bearing race (11).
- (8) Remove pitot collector (12).

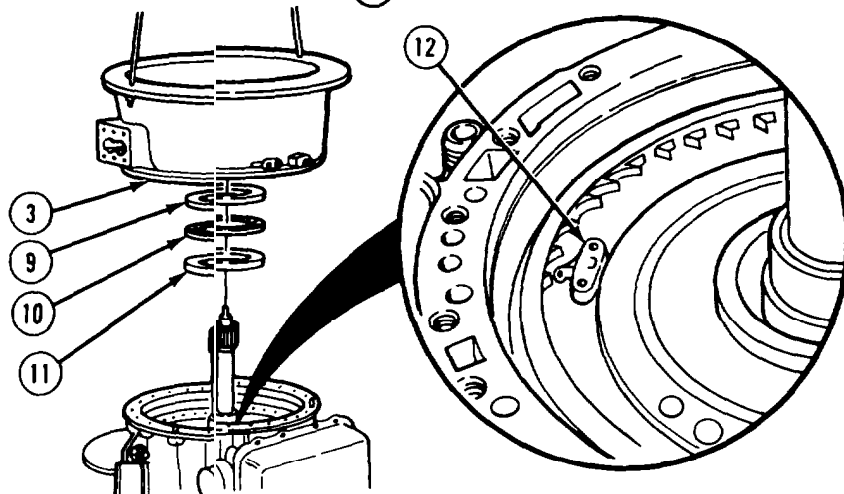

Transmission Maintenance Instructions (Cont)

- (9) Soldier A guides torque converter housing (3) to work surface while Soldier B operates lifting device.
- (10) Remove lifting device and lifting eyes.

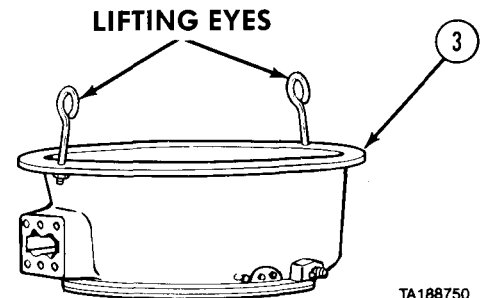

- (11) Soldier A and Soldier B turn torque converter housing (3) over.
- (12) Remove two seal rings (13) from support hub (14).

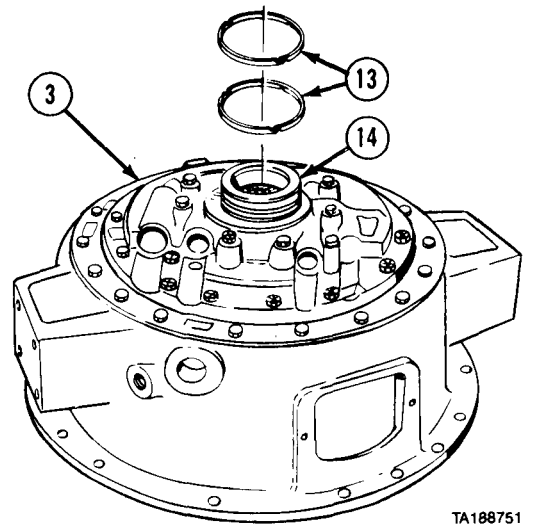

b. Disassembly.

- (1) Set torque converter housing (1) on two wooden blocks.

CAUTION

When screws are removed, oil pump will fall. Support oil pump to prevent damage.

- (2) Remove six screws (2) holding oil pump to front support assembly (3).

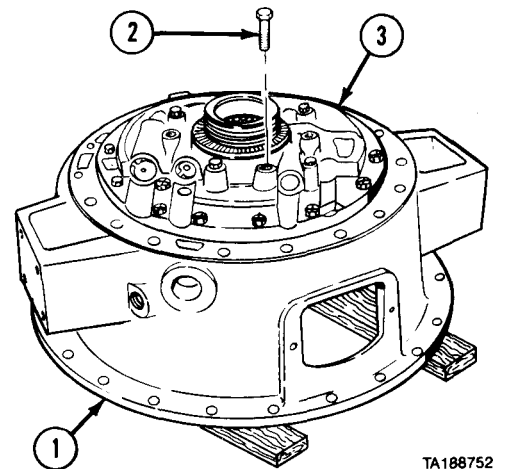

7-9. TORQUE CONVERTER HOUSING REMOVAL/REPAIR/INSTALLATION (CONT).

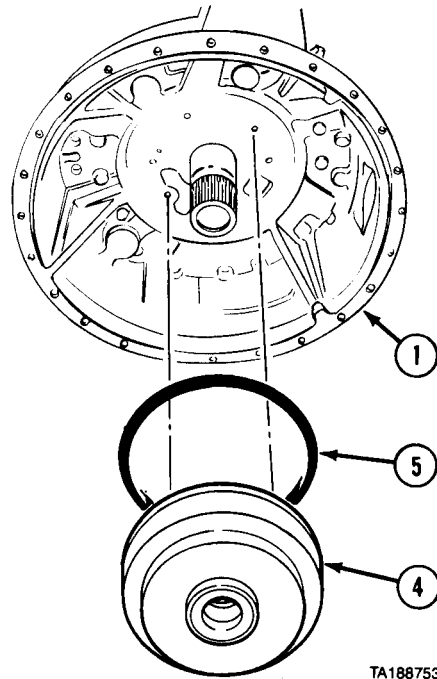

TA188753

- (3) Soldier A and Soldier B remove oil pump (4) from under torque converter housing (1).
- (4) Remove outer seal ring (5) from oil pump (4).
- (5) Remove screw (6) from oil pump (4).
- (6) Remove backplate (7) from oil pump (4).
- (7) Remove drive gear (8).
- (8) Remove driven gear (9).
- (9) Remove bearing (10) from driven gear (9).
- (10) Set oil pump (4) on rim and remove oil seal (11) from groove (12).

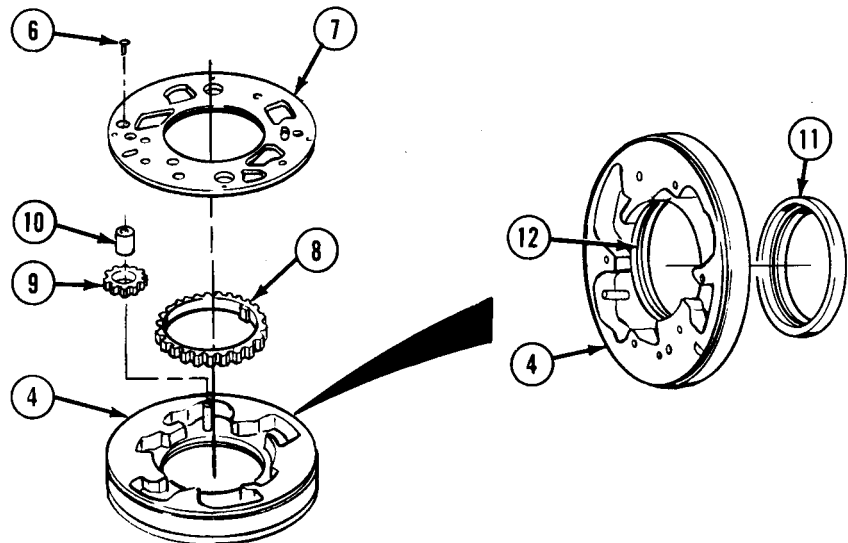

TA188755

Transmission Maintenance Instructions (Cont)

WARNING

Parts are under spring tension. Release tension slowly to prevent personal injury.

- (11) Soldier A removes retaining ring (13) while Soldier B pushes support assembly (14).

NOTE

Tag and mark all parts.

- (12) Remove support assembly (14), valve seat (15), converter bypass valve (16) and spring (17).

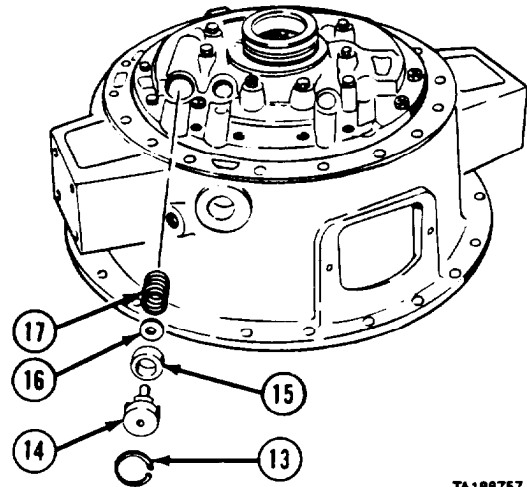

TA188757

- (13) Soldier A removes retaining ring (18) while Soldier B pushes retainer washer (19).

NOTE

Tag and mark all parts.

- (14) Remove retainer washer (19), valve stop (20), valve spring (21), and lockup shift valve (22).

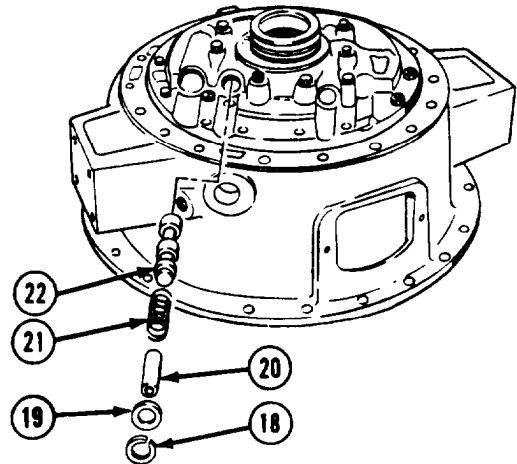

TA188758

- (15) Soldier A removes retaining ring (23) while Soldier B pushes retainer washer (24).

NOTE

Tag and mark all parts.

- (16) Remove retainer washer (24) valve stop (25), main pressure regulator valve spring (26), and main pressure regulator valve (27).
 (17) Remove 15 screws (28) holding front support assembly (3) to torque converter housing (1).
 (18) Remove three screws (29).
 (19) Remove screw (30).

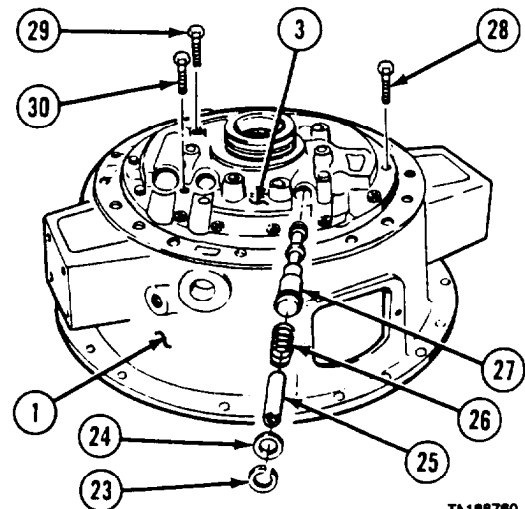

TA188760

Transmission Maintenance Instructions (Cont)

7-9. TORQUE CONVERTER HOUSING REMOVAL/REPAIR/INSTALLATION (CONT).

- (20) Soldier A and Soldier B position and hold torque converter housing (1) on rim.
- (21) Soldier A and Soldier B remove front support assembly (3).
- (22) Remove gasket (31) from torque converter housing (1).

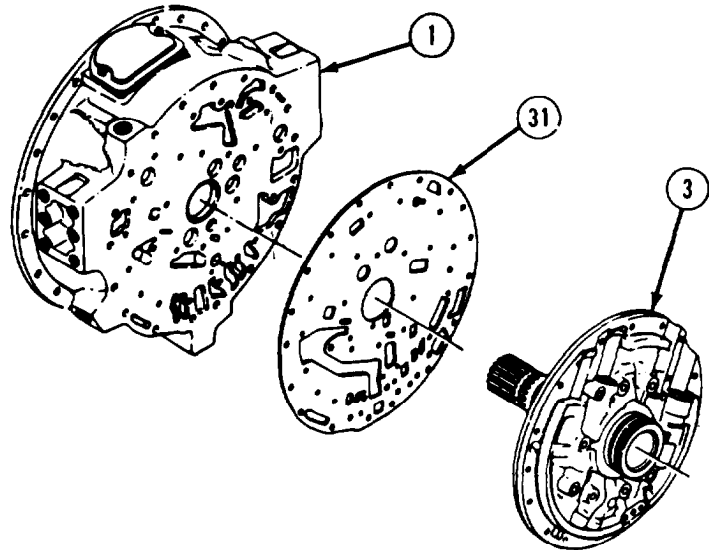

- (23) Remove bearing (32) from ground sleeve bore (33).

c. Cleaning/Inspection.

WARNING

Adhesives, solvents, and sealing compounds can burn easily, can give off harmful vapors, and are harmful to skin and clothing. To avoid injury or death, keep away from open fire and use in well-ventilated area. If adhesive, solvent, or sealing compound gets on skin or clothing, wash immediately with soap and water.

- (1) Clean all metallic parts with drycleaning solvent and inspect for damage. If there is damage, replace parts.
- (2) Converter bypass valve spring, lockup shift valve spring, and main pressure regulator valve spring must be replaced if load-height specifications, listed in Table 7-1, are not met.

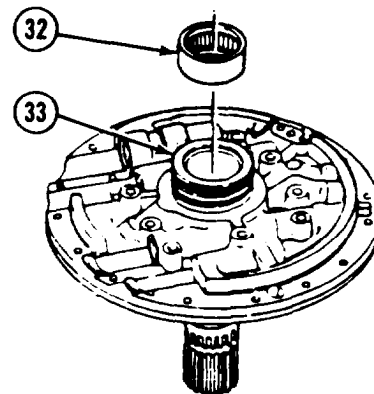

Table 7-1. Valve Spring Load-Height Specifications

Spring	Length Without Load	Length Under Load	Load
Converter bypass valve	2.65 in. (67.3 mm)	1.62 in. (41.2 mm)	21.1 to 23.3 lb (93.9 to 103.6 N•m)
Lockup shift valve	3.22 in. (81.8 mm)	1.8 in. (45.7 mm)	22.10 to 23.50 lb (98.3 to 104.5 N•m)
Main regulator valve	3.94 in. (100.1 mm)	2.64 in. (67.1 mm)	82.4 to 86.6 lb (366.5 to 385.2 N•m)

Transmission Maintenance Instructions (Cont)

d. Assembly.

- (1) Install bearing (1) in ground sleeve bore (2) using bearing installer.

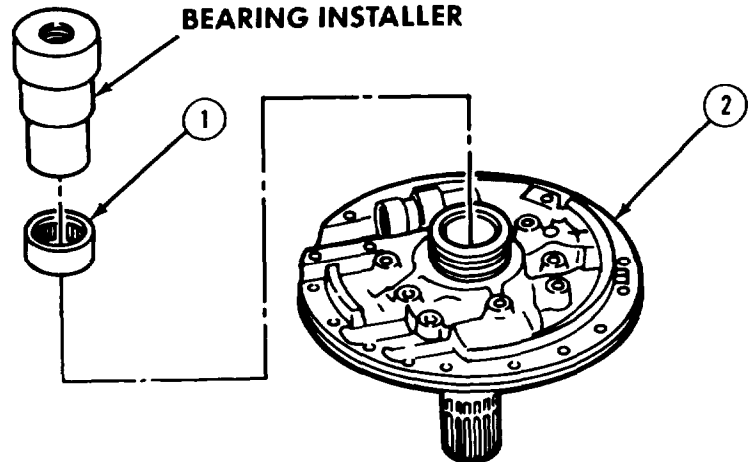

- (2) Set torque converter housing (3) on wooden blocks.
- (3) Install gasket (4) on torque converter housing (3).
- (4) Aline holes and install front support assembly (5).

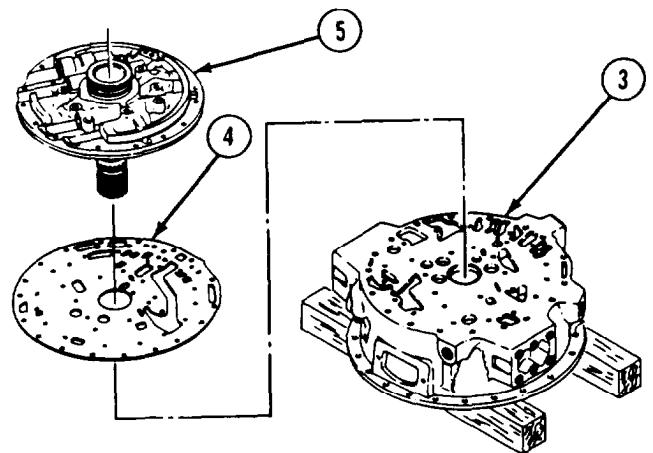

- (5) Install three screws (6) across front support assembly (5).
- (6) Install 15 screws (7) around outer edge of front support assembly (5).
- (7) Install screw (8).
- (8) Tighten three screws (6), 15 screws (7), and screw (8) to 36 to 43 lb-ft (49 to 58 N•m).
- (9) Install main pressure regulator valve (9) small end first.
- (10) Install main pressure regulator valve spring (10) and valve stop (11).
- (11) Install retainer washer (12) on main pressure regulator valve spring (10).
- (12) Soldier A installs retaining ring (13) while Soldier B pushes retainer washer (12).

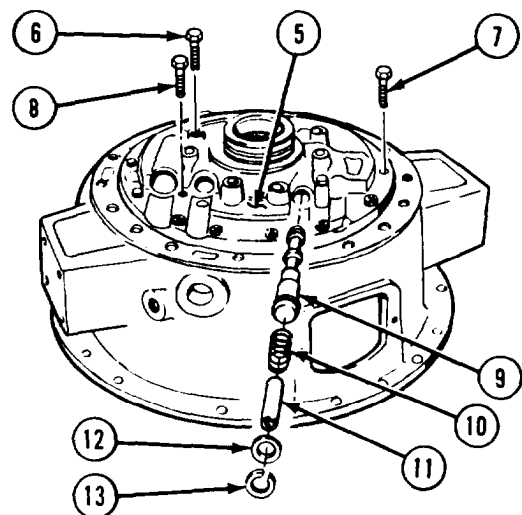

Transmission Maintenance Instructions (Cont)

7-9. TORQUE CONVERTER HOUSING REMOVAL/REPAIR/INSTALILATION (CONT).

- (13) Install lockup shift valve (14) small end first.
- (14) Install valve spring (15) and valve stop (16).
- (15) Install retainer washer (17) on valve spring (15).
- (16) Soldier A installs retaining ring (18) while Soldier pushes retainer washer (17).

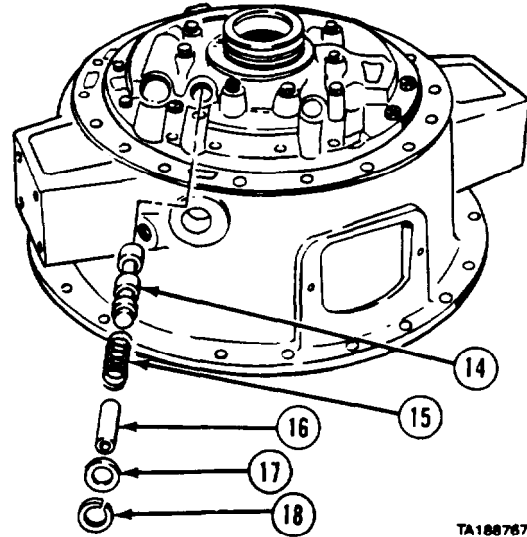

- (17) Install spring (19), converter bypass valve (20) valve seat (21) and support assembly (22).
- (18) Soldier A installs retaining ring (23) while Soldier pushes against support assembly (22).

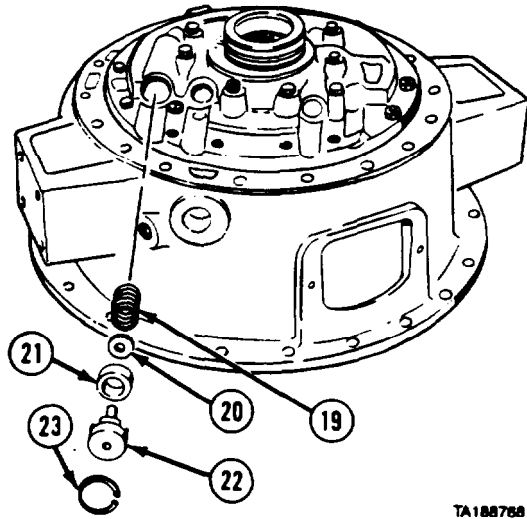

- (19) Install bearing (24) in driven gear (25).
- (20) Install driven gear (25) on shaft (26).
- (21) Install drive gear (27) in oil pump (28).

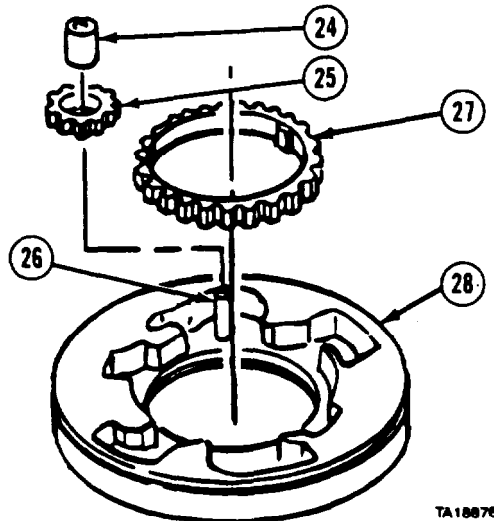

Transmission Maintenance Instructions (Cont)

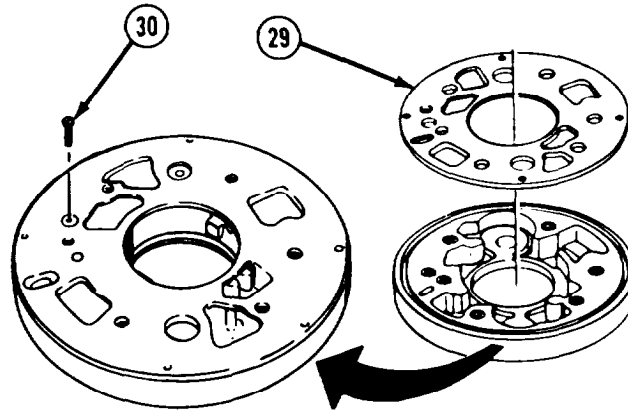

- (22) Install backplate (29).
- (23) Install screw (30). Tighten screw to 9 to 11 lb-ft (12 to 15 N•m).

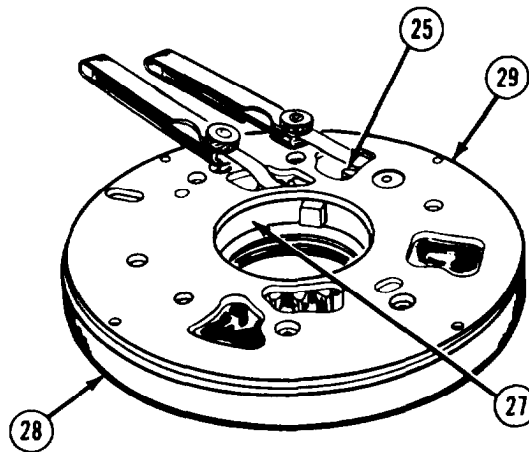

- (24) Check clearance between backplate (29), drive gear (27), and driven gear (25). Maximum clearance is 0.006 in. (0.15 mm).
- (25) Turn oil pump (28) over.
- (26) Apply lubricating oil to rubber lip of oil seal (31) and install oil seal in oil pump (28).

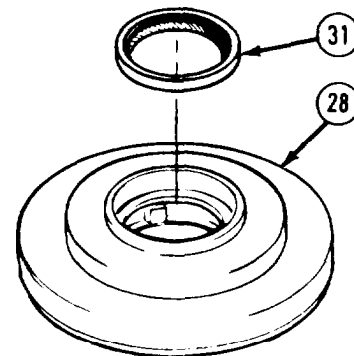

Transmission Maintenance Instructions (Cont)

7-9. TORQUE CONVERTER HOUSING REMOVAL/REPAIR/INSTALLATION (CONT).

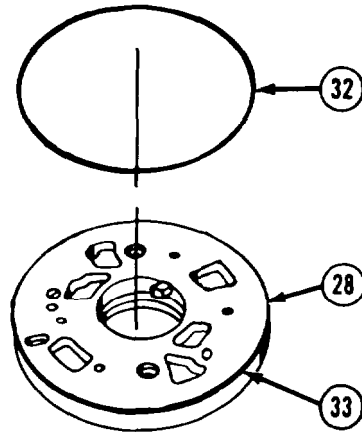

- (27) Coat outer seal ring (32) with lubricating oil and install outer seal ring in groove (33) on oil pump (28).

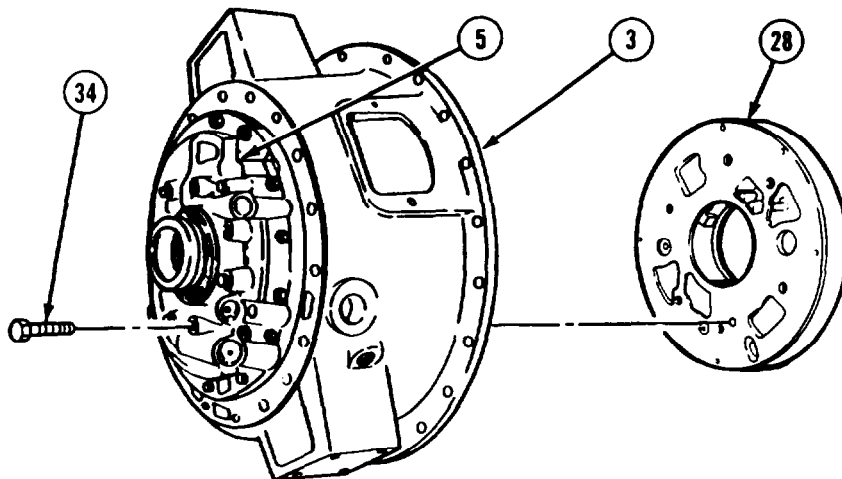

- (28) Turn torque converter housing (3) on side.
- (29) Aline screw holes in oil pump (28) with holes in torque converter housing (3).
- (30) Soldier A installs oil pump (28) while Soldier B holds torque converter housing (3).
- (31) Soldier A installs six screws (34) through front support (5) while Soldier B holds oil pump (28).
- (32) Tighten six screws (34) to 26 to 32 lb-ft (35 to 43 N•m).

Transmission Maintenance Instructions (Cont)

e. Installation.

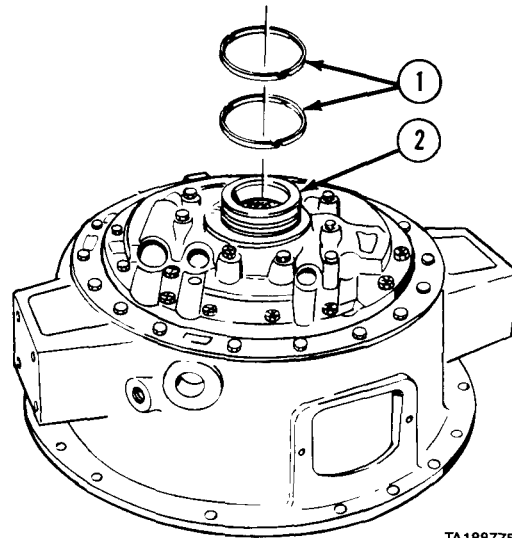

CAUTION

Keep seal rings sealed in package until ready to use to keep from being damaged.

- (1) Roll seal ring (1) to one-half length and hold for at least 10 seconds.
- (2) Install seal ring (1) in lower groove of support hub (2).
- (3) Roll seal ring (1) to one-half length and hold for 10 seconds.
- (4) Install seal ring (1) in upper groove of support hub (2).

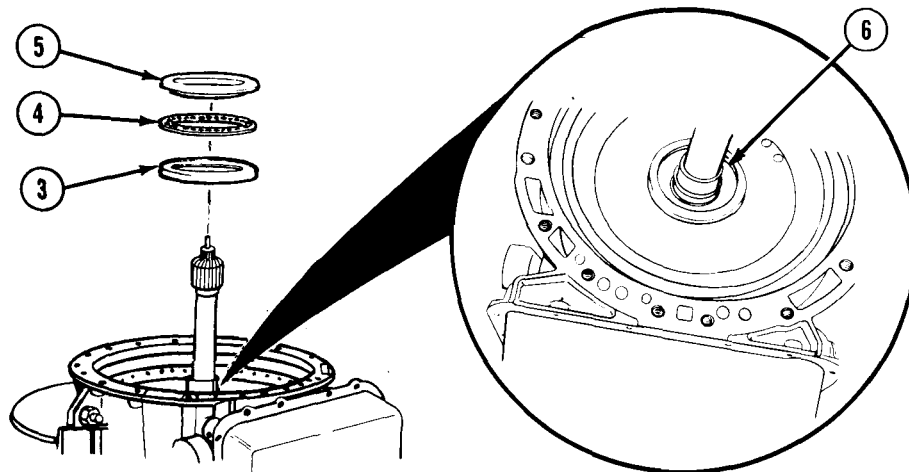

- (5) Install bearing race (3), roller bearing (4), and bearing race (5) on inner bore (6).

7-9. TORQUE CONVERTER HOUSING REMOVAL/REPAIR/INSTALLATION (CONT).

NOTE

Guide screws are installed in side of pitot tube with one hole in center.

(6) Install two guide screws in pitot tube (7).

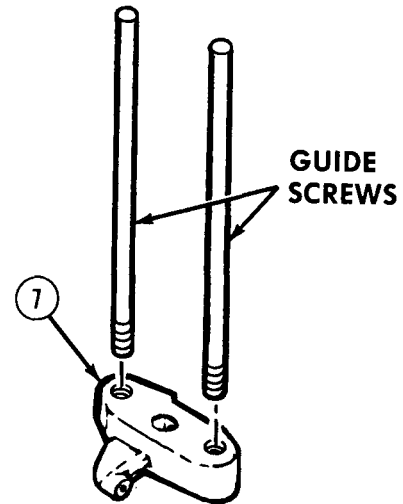

TA188777

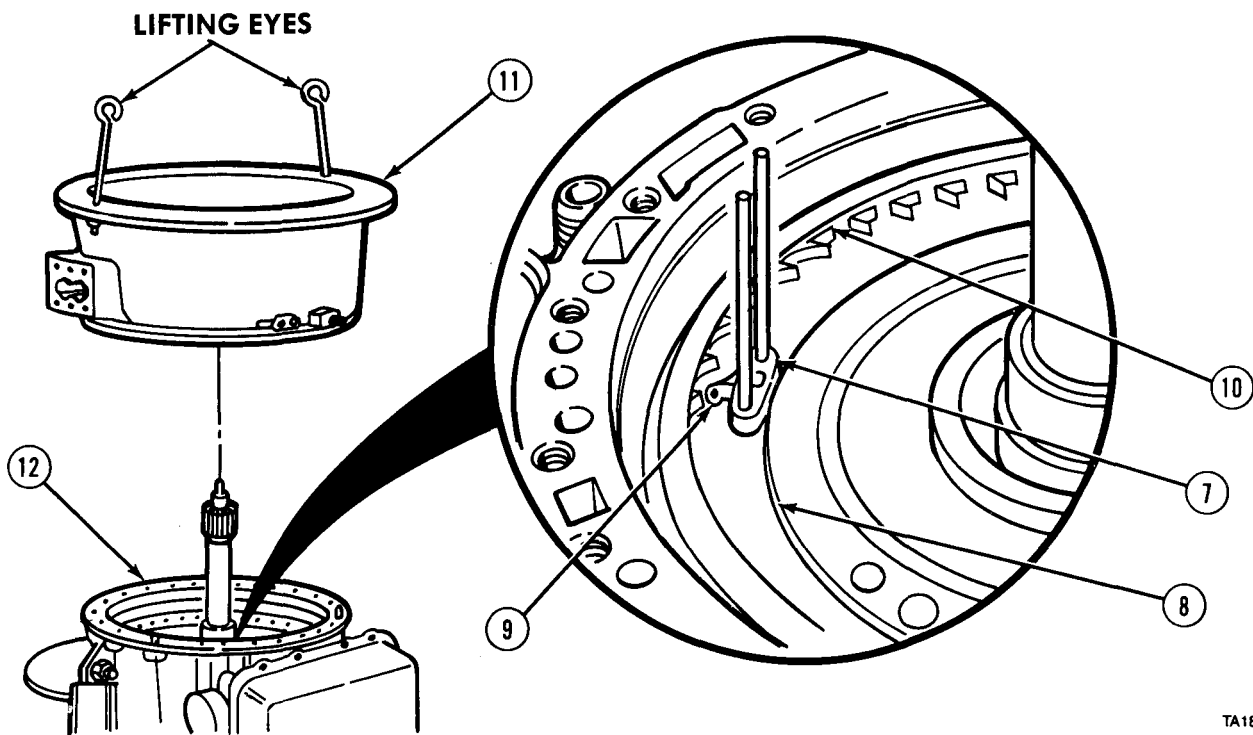

TA188778

- (7) Position pitot tube (7) on forward clutch housing (8) with tip (9) under pitot collector ring (10).
- (8) Install lifting eyes and lifting device on torque converter housing (11).
- (9) Position torque converter housing (11) over transmission housing (12).

Transmission Maintenance Instructions (Cont)

- (10) Soldier A aligns two pitot tube guide screws with two small holes in torque converter housing (11) while Soldier B operates lifting device.

CAUTION

Take care not to damage pitot tube and collector ring when installing converter housing.

- (11) Install torque converter housing (11) on transmission housing (12).
- (12) Remove lifting device and lifting eyes.

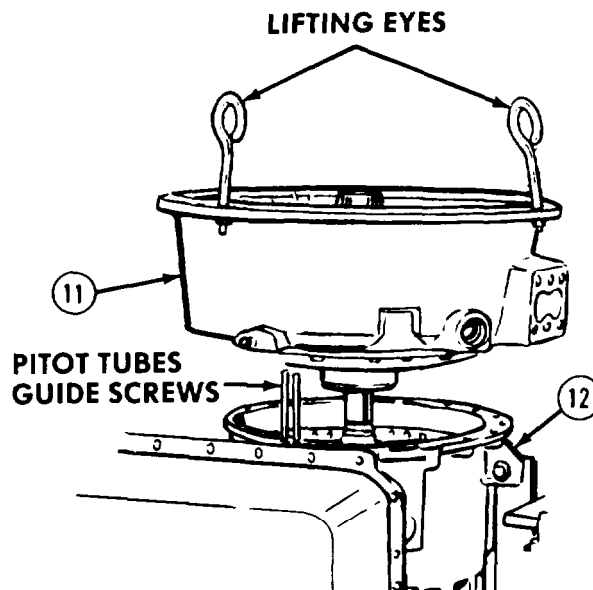

NOTE

Move pitot tube guide screws up and down to check that pitot tube is free.

- (13) Install seven screws (13) and lockwashers (14). Tighten screws to 67 to 80 lb-ft (90 to 108 N•m).

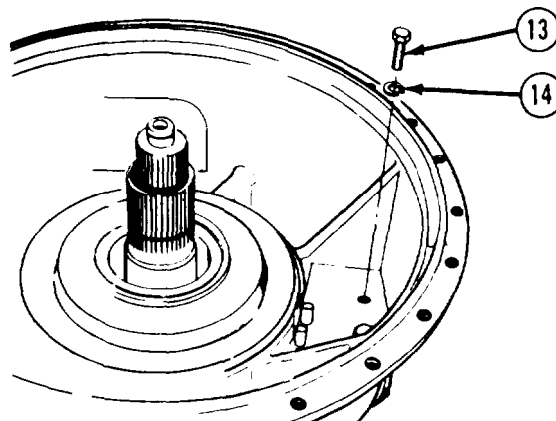

WARNING

Adhesives, solvents, and sealing compounds can burn easily, can give off harmful vapors, and are harmful to skin and clothing. To avoid injury or death, keep away from open fire and use in well-ventilated area. If adhesive, solvent, or sealing compound gets on skin or clothing, wash immediately with soap and water.

- (14) Apply small amount of silicone adhesive-sealant to two screws (15) and washers (16).
- (15) Remove one pitot tube guide screw and install screw (15) and washer (16).
- (16) Remove other pitot tube guide screw and install screw (15) and washer (16).
- (17) Tighten screws (15) to 30 to 48 lb-in. (266 to 425 N•m).

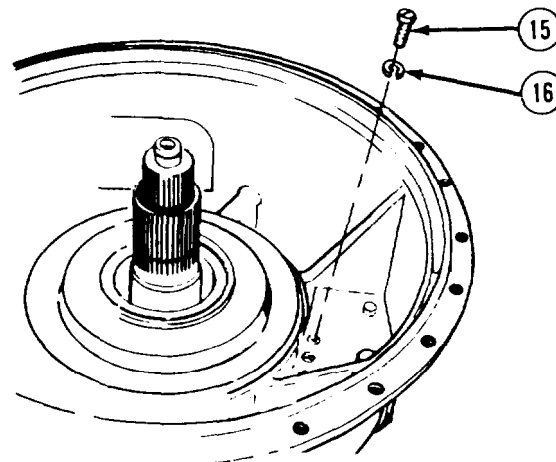

Transmission Maintenance Instructions (cont)

7-9. TORQUE CONVERTER HOUSING REMOVAL/REPAIR/INSTALLATION (CONT).

NOTE

Nine screws and lockwashers are used to install torque converter housing on transmission housing. Two screws and lockwashers must be installed after lifting eyes are removed.

- (18) Install seven screws (17) and lockwashers (18) to hold torque converter housing (11) to transmission housing (12). Tighten screws to 67 to 80 lb-ft (91 to 108 N•m).

f. **Follow-on Maintenance.** Install torque converter pump in torque converter housing (para 7-8).

END OF TASK

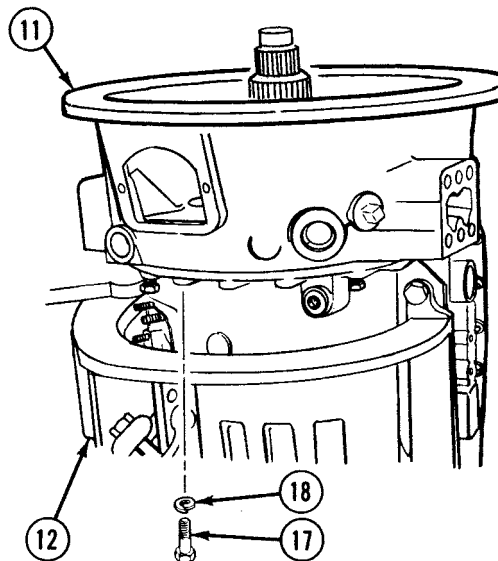

7-10. TRANSMISSION HOUSING REPAIR.

This task covers:

- a. Disassembly
- b. Cleaning/Inspection
- c. Assembly
- d. Follow-on Maintenance

INITIAL SETUP

Models
All

Test Equipment
None

Special Tools
Manual shaft oil seal installer J26282
Manual shaft oil seal remover J26401

Supplies
Solvent, drycleaning, Item 57, Appendix C
Compound, sealing, lubricating, Item 25, Appendix C

Personnel Required
MOS 63W, Wheel vehicle repairer

References
None

Equipment Condition

<i>TM or Para</i>	<i>Condition Description</i>
TM 9-2320-279-20	Transmission breather removed.
TM 9-2320-279-20	Neutral safety switch removed.
Para 7-16	Rear cover and first clutch assembly removed.
Para 7-13	Gear unit and main shaft assembly removed.

Special Environmental Conditions
None

General Safety Instructions
None

Level of Maintenance
General Support

Transmission Maintenance Instructions (Cont)

a. Disassembly.

- (1) Remove nut (1) from manual shaft (2).
- (2) Remove selector lever (3) from manual shaft (2).

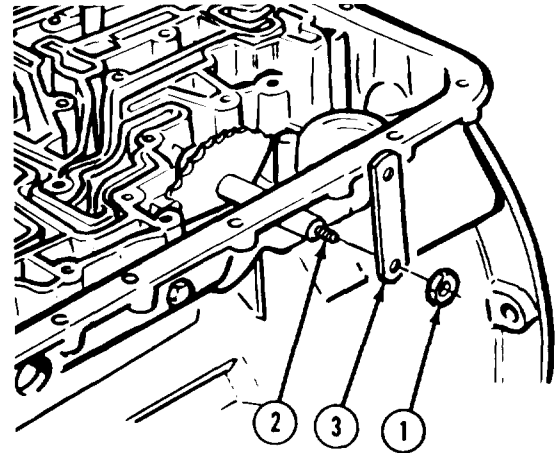

- (3) Remove cotter pin (4).
- (4) Remove locknut (5).
- (5) Hold detent lever (6) with one hand and remove manual shaft (2) by pulling shaft through oil seal (7).
- (6) Remove detent lever (6) from transmission housing (8).

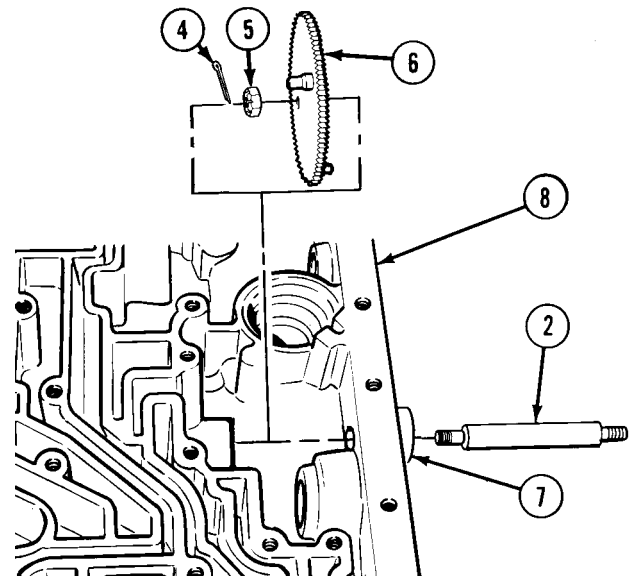

- (7) Remove oil seal (7) using manual shaft oil seal remover.
- (8) Remove governor pressure tap plug (9).

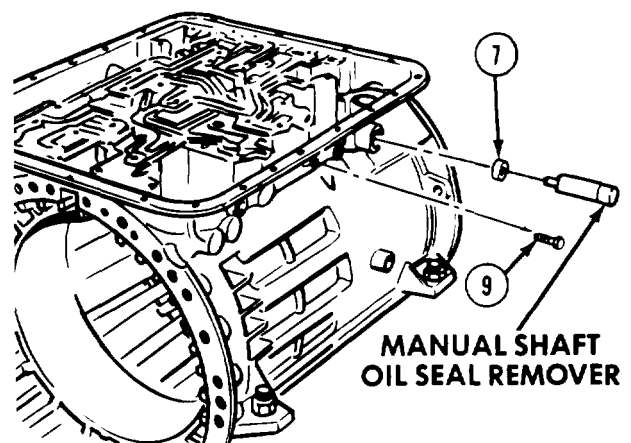

Transmission Maintenance Instructions (Cont)

7-10. TRANSMISSION HOUSING REPAIR (CONT).

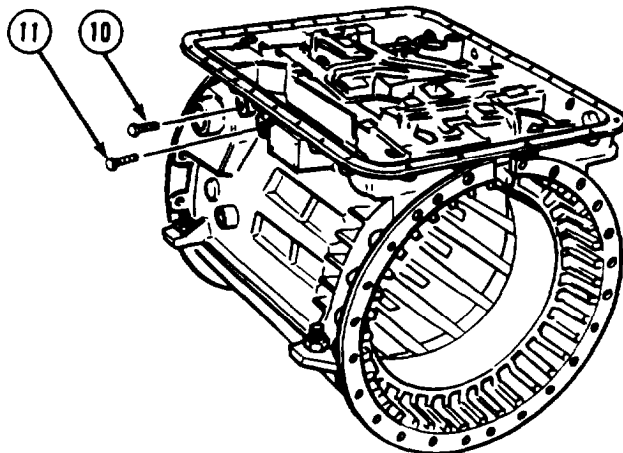

TA188610

- (9) Remove fourth clutch pressure tap plug (10).
- (10) Remove reverse signal switch plug (11).

- (11) Remove five studs (12).

b. Cleaning/Inspection.

WARNING

Adhesives, solvents, and sealing compounds can burn easily, can give off harmful vapors, and are harmful to skin and clothing. To avoid injury or death, keep away from open fire and use in well-ventilated area. If adhesive, solvent, or sealing compound gets on skin or clothing, wash immediately with soap and water.

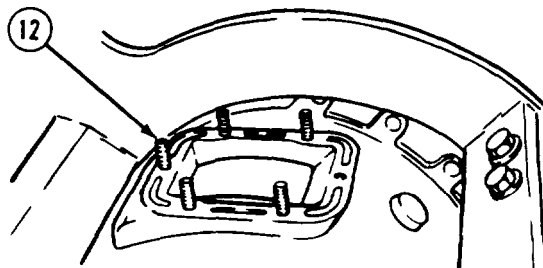

TA188611

- (1) Clean transmission housing and all metal parts with dry cleaning solvent.
- (2) Inspect parts for damage. Replace damaged parts.
- (3) If signs of damage to transmission housing are noted, replace transmission housing.

c. Assembly.

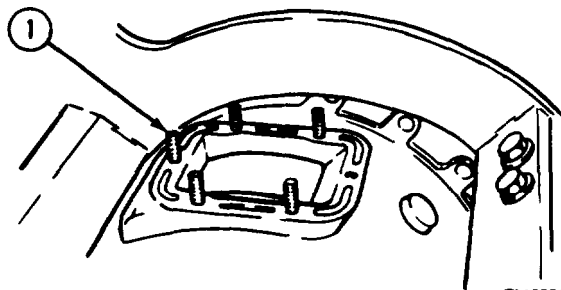

TA188612

- (1) Install five studs (1).

Transmission Maintenance Instructions (Cont)

- (2) Install reverse signal switch plug (2).
- (3) Install fourth clutch pressure tap plug (3).

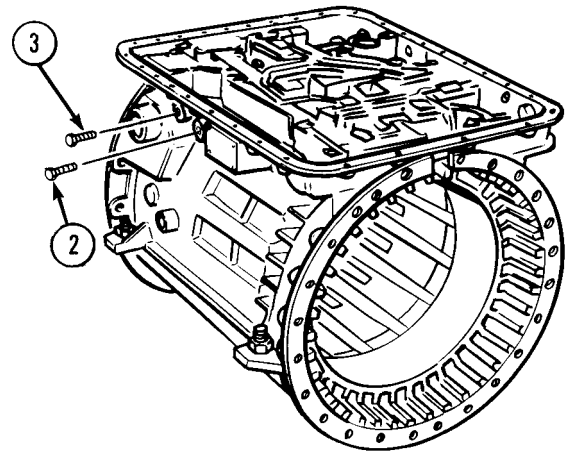

- (4) Install governor pressure tap plug (4).

WARNING

Adhesives, solvents, and sealing compounds can burn easily, can give off harmful vapors, and are harmful to skin and clothing. To avoid injury or death, keep away from open fire and use in well-ventilated area. If adhesive, solvent, or sealing compound gets on skin or clothing, wash immediately with soap and water.

- (5) Coat outside of oil seal (5) with sealing and lubricating compound and install oil seal in transmission housing (6) using manual shaft oil seal installer.

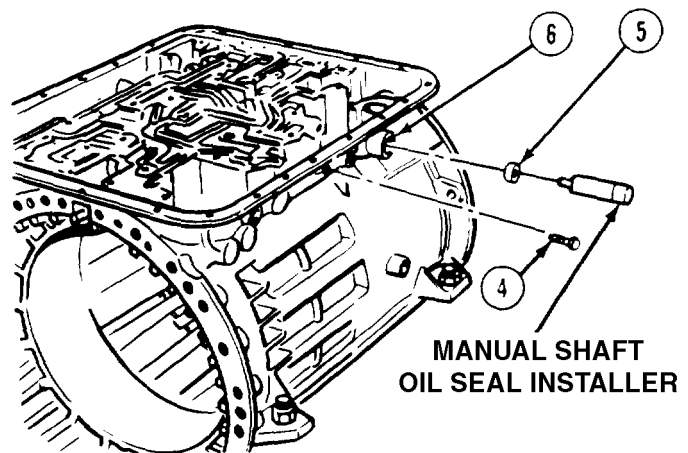

- (6) Position detent lever (7) in transmission housing (6) with selector pin pointing to inside of housing.
- (7) Install manual shaft (8) by pushing shaft through oil seal (5) in transmission housing (6) and slot in detent lever (7).
- (8) Install locknut (9) on manual shaft (8).
- (9) Tighten locknut (9) to 15 to 20 lb-ft (20 to 27 N•m).
- (10) Install cotter pin (10).

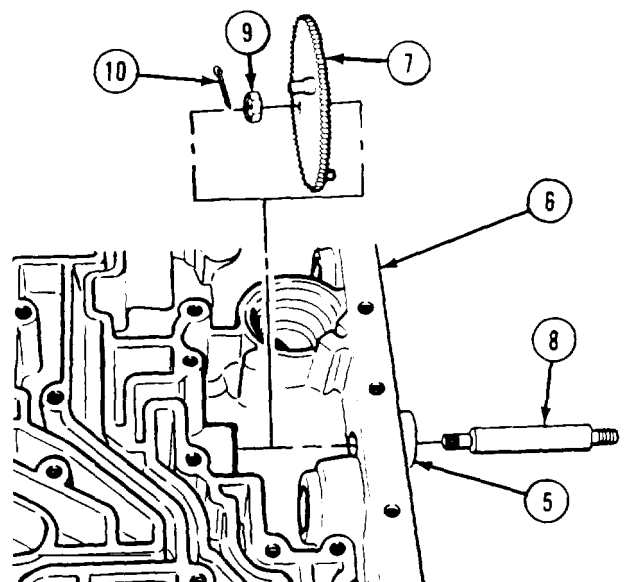

Transmission Maintenance Instructions (Cont)

7-10. TRANSMISSION HOUSING REPAIR (CONT.).

- (11) Install selector lever (11) on manual shaft (7).
- (12) Install nut (12) on manual shaft (7).

d. Follow-on Maintenance.

- (1) Install gear unit and main shaft assembly (para 7-13).
- (2) Install rear cover and first clutch assembly (para 7-16).
- (3) Install transmission breather (TM 9-2320-279-20).
- (4) Install neutral safety switch (TM 9-2320-279-20).

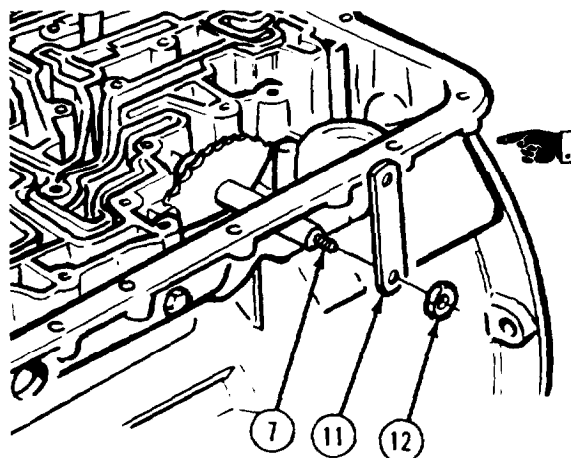

END OF TASK

Section V. OIL PAN AND INTERNAL FILTER

7-11. OIL PAN REMOVAL/INSTALLATION.

This task covers:

- a. Disassembly
- b. Installation
- c. Follow-on Maintenance

INITIAL SETUP

Models
All

References
None

Test Equipment
None

Equipment Condition

<i>TM or Para</i>	<i>Condition Description</i>
LO 9-2320-279-12	Transmission oil drained.

Special Tools
None

Para 7-4
Transmission dipstick tube removed.

Supplies
 Compound, sealing, pipe thread, Item 29, Appendix C
 Grease, automotive and artillery, Item 34, Appendix C

TM 9-2320-279-20
Transmission shift cable removed.

Special Environmental Conditions
None

Personnel Required
MOS 63W, Wheel vehicle repairer

General Safety Instructions
None

Level of Maintenance
Direct Support

Transmission Maintenance Instructions (Cont)

a. Removal.

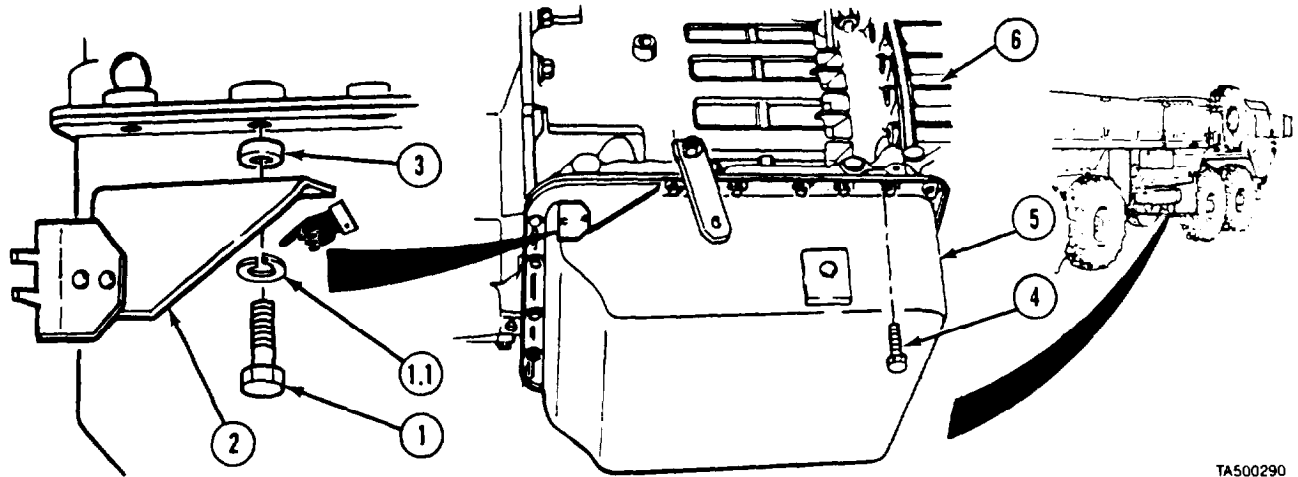

TA500290

- (1) Remove two screws (1), lockwashers (1.1), bracket (2), and two spacers (3).

NOTE

Support oil pan while removing screws.

- (2) Remove remaining 21 screws (4) holding oil pan (5) to transmission (6).

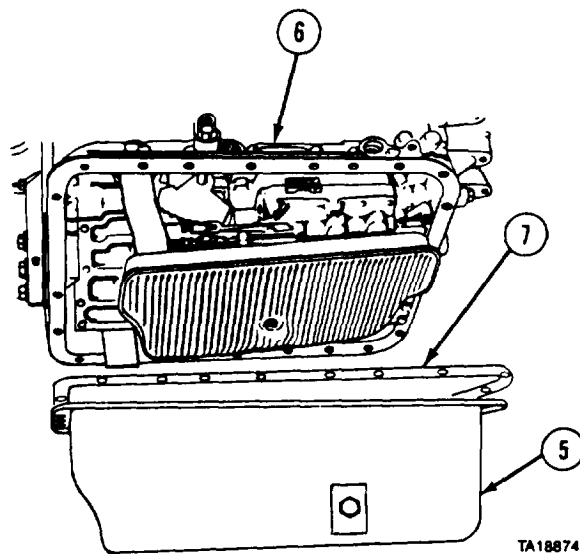

TA188741

- (3) Remove oil pan (5) from transmission (6).
- (4) Remove gasket (7) from oil pan (5).

Transmission Maintenance Instructions (Cont)

7-11. OIL PAN REMOVAL/INSTALLATION (CONT).

- (5) Remove plug (8).
- (6) Remove plug (9).
- (7) Remove plug (10) and washer (11).

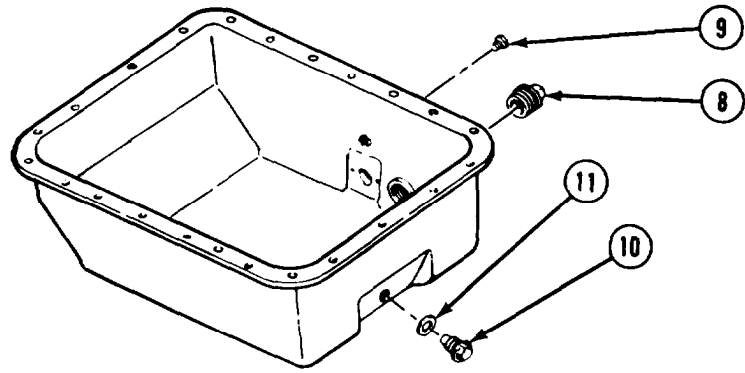

b. Installation.

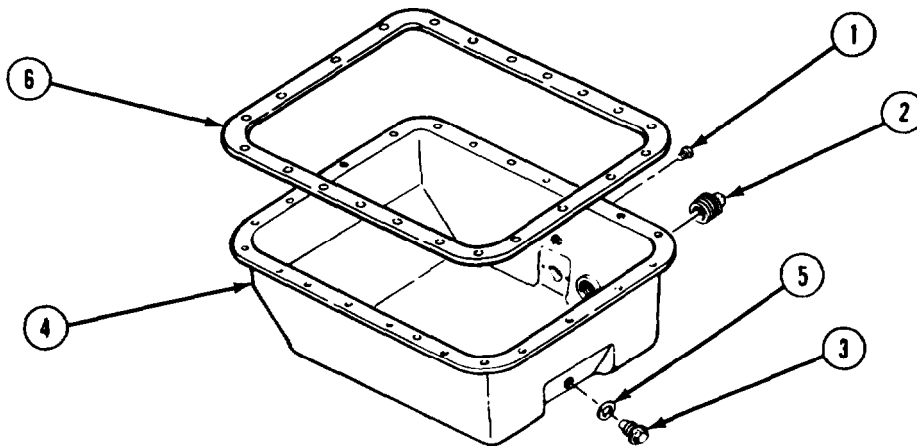

WARNING

Adhesives, solvents, and sealing compounds can burn easily, can give off harmful vapors, and are harmful to skin and clothing. To avoid injury or death, **keep** away from open fire and use in well-ventilated area. If adhesive, solvent, or sealing compound gets on skin or clothing, wash immediately with soap and water.

- (1) Lightly coat threads of plugs (1, 2, and 3) with pipe thread sealing compound.
- (2) Install plug (1) in oil pan (4).
- (3) Install plug (2).
- (4) Install plug (3) and washer (5). Torque plug (3) to 15 to 20 lb-ft (20 to 27 N•m).
- (5) Apply grease to lip of oil pan (4) and install gasket (6).

Transmission Maintenance Instructions (Cont)

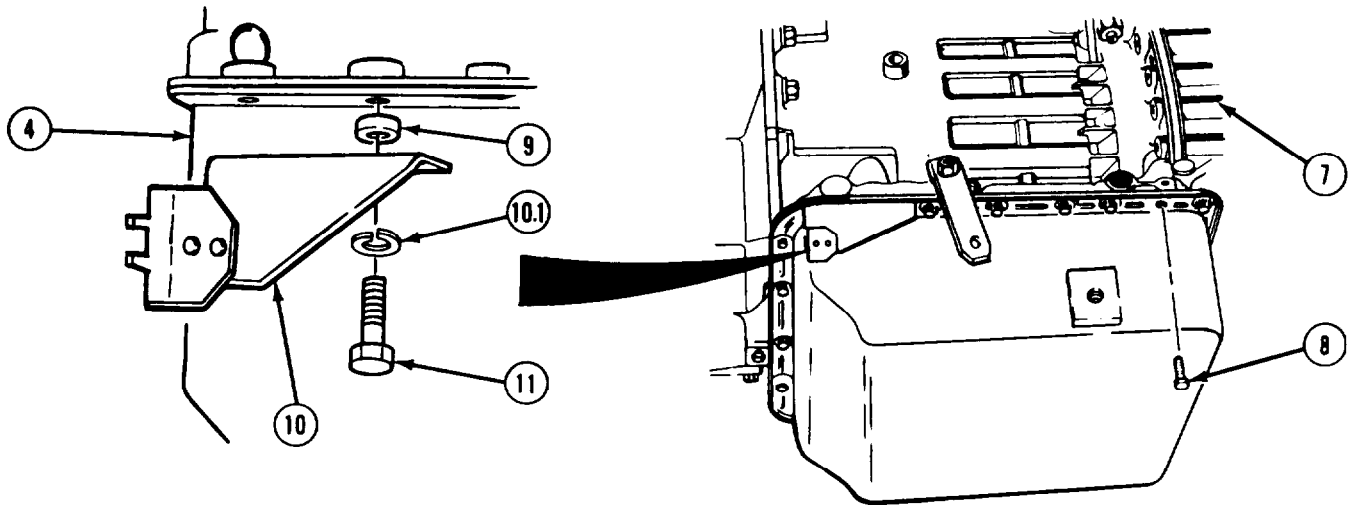

- (6) Install oil pan (4) on transmission (7) with 21 screws (8). Do not tighten screws.
- (7) Install two spacers (9), bracket (10), two lockwashers (10.1), and two screws (11) on oil pan (4). Do not tighten screws.

NOTE

Oil pan has to be drawn evenly to transmission.

- (8) Alternately tighten each screw (8 and 11), 180° apart in a crisscross pattern, to 10 lb-ft (14 N•m).
- (9) Tighten each screw (8 and 11) again, using same pattern, to 17 to 20 lb-ft (23 to 27 N•m).

C. **Follow-on Maintenance.**

- (1) Install transmission dipstick (para 7-4).
- (2) Install shift cable (TM 9-2320-279-20).
- (3) Fill transmission with oil (LO 9-2320-279-12).
- (4) Check for leaks.

END OF TASK

Transmission Maintenance Instructions (Cont)

7-12. INTERNAL FILTER ELEMENT REMOVAL/INSTALLATION.	
This task covers:	
a. Removal	c. Follow-on Maintenance
b. Installation	
INITIAL SETUP	
<i>Models</i>	<i>References</i>
All	None
<i>Test Equipment</i>	<i>Equipment Condition</i>
None	<i>TM or Para</i> <i>Condition Description</i>
<i>Special Tools</i>	Para 7-11 Oil pan removed.
None	
<i>Supplies</i>	<i>Special Environmental Conditions</i>
Oil, lubricating, Item 46, Appendix C	None
<i>Personnel Required</i>	<i>General Safety Instructions</i>
MOS 63W, Wheel vehicle repairer	None
	<i>Level of Maintenance</i>
	Direct Support

a. Removal.

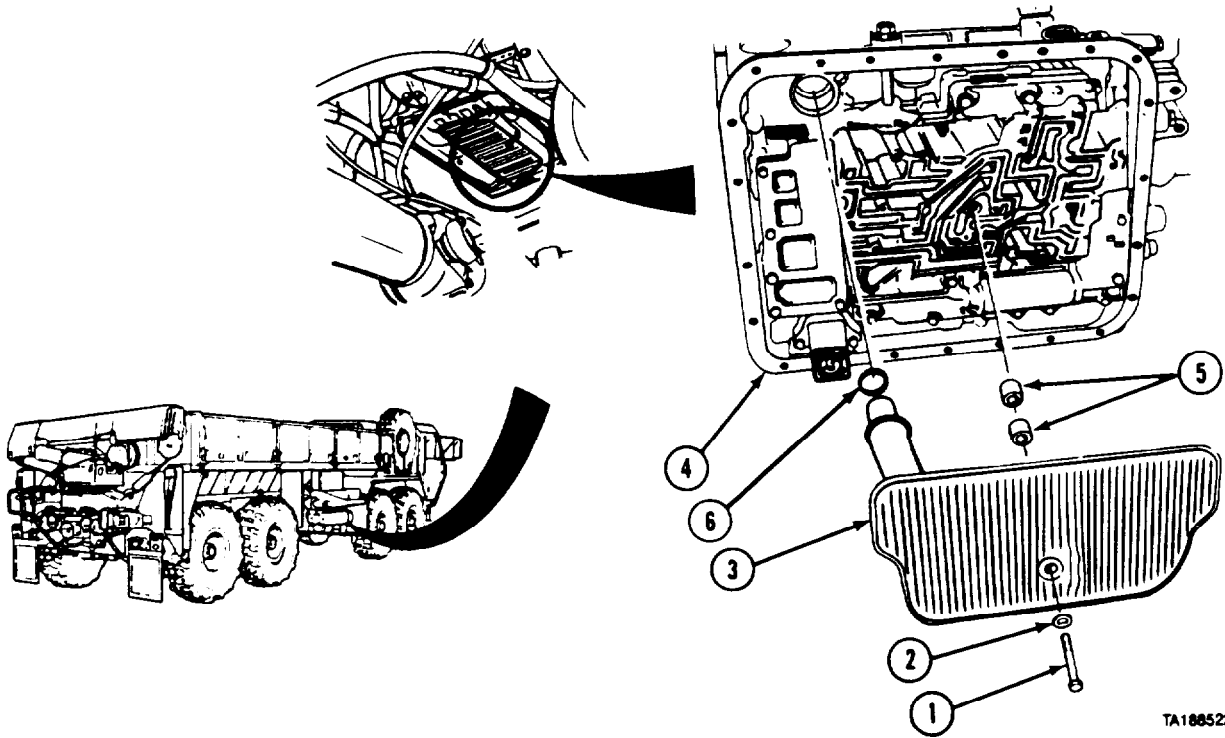

TA188522

- (1) Remove screw (1), washer (2), and filter element (3) from transmission (4).
- (2) Remove two spacers (5).
- (3) Remove preformed packing (6) from filter element (3).

Transmission Maintenance Instructions (Cont)

b. Installation.

- (1) Coat preformed packing (6) with lubricating oil and install preformed packing on filter element (3).
- (2) Install screw (1) with washer (2) through filter element (3) and two spacers (5).
- (3) Install filter element (3) in transmission (4).
- (4) Tighten screw (1) to 17 to 20 lb-ft (23 to 27 N•m).

C. **Follow-on Maintenance.** Install oil pan (para 7-11).

END OF TASK

Section VI. GEAR UNIT AND MAIN SHAFT

7-13. GEAR UNIT AND MAIN SHAFT ASSEMBLY REMOVAL/REPAIR/INSTALLATION		
This task covers:		
a. Removal	d. Assembly	
b. Disassembly	e. Installation	
c. Cleaning/Inspection	f. Follow-on Maintenance	
INITIAL SETUP		
<i>Models</i> All	<i>Personnel Required</i> MOS 63W, Wheel vehicle repairer (2)	
<i>Test Equipment</i> None	<i>References</i> None	
<i>Special Tools</i> Sun gear bushing reamer set J28489 Bushings installer J24201 Main shaft lifting bracket J24196 Bushings swaging tool J26997-A Bushings installer J25458-3 Pilot tool J28489	<i>Equipment Condition</i>	
	<i>TM or Para</i> Para 7-19	<i>Condition Description</i> Second clutch and center support housing removed.
	<i>Special Environmental Conditions</i> None	
	<i>General Safety Instructions</i> None	
	<i>Level of Maintenance</i> General Support	
<i>Supplies</i> Solvent, drycleaning, Item 57, Appendix C Compound, sealing, lubricating, Item 25, Appendix C Oil, lubricating, Item 46, Appendix C Tag, identification, Item 60, Appendix C		

Transmission Maintenance Instructions (Cont)

7-13. GEAR UNIT AND MAIN SHAFT ASSEMBLY REMOVAL/REPAIR/INSTALLATION (CONT).

a. Removal.

- (1) Install lifting bracket to main shaft (1) of gear unit assembly (2) and secure lifting device to bracket.
- (2) Soldier A removes gear unit assembly (2) from transmission housing (3) while Soldier B operates lifting device.
- (3) Remove lifting bracket.

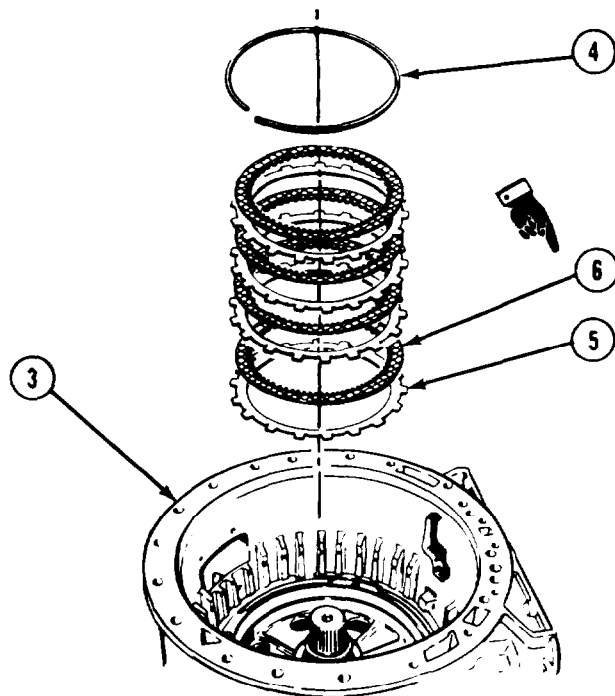
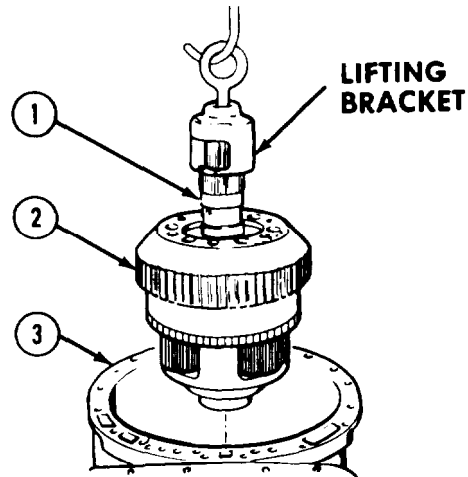

NOTE

Tag retaining ring and backing plate.

- (4) Remove retaining ring (4).
- (5) Remove 12 second clutch plates (5 and 6) from transmission housing (3).

Transmission Maintenance Instructions (Cont)

b. Disassembly.

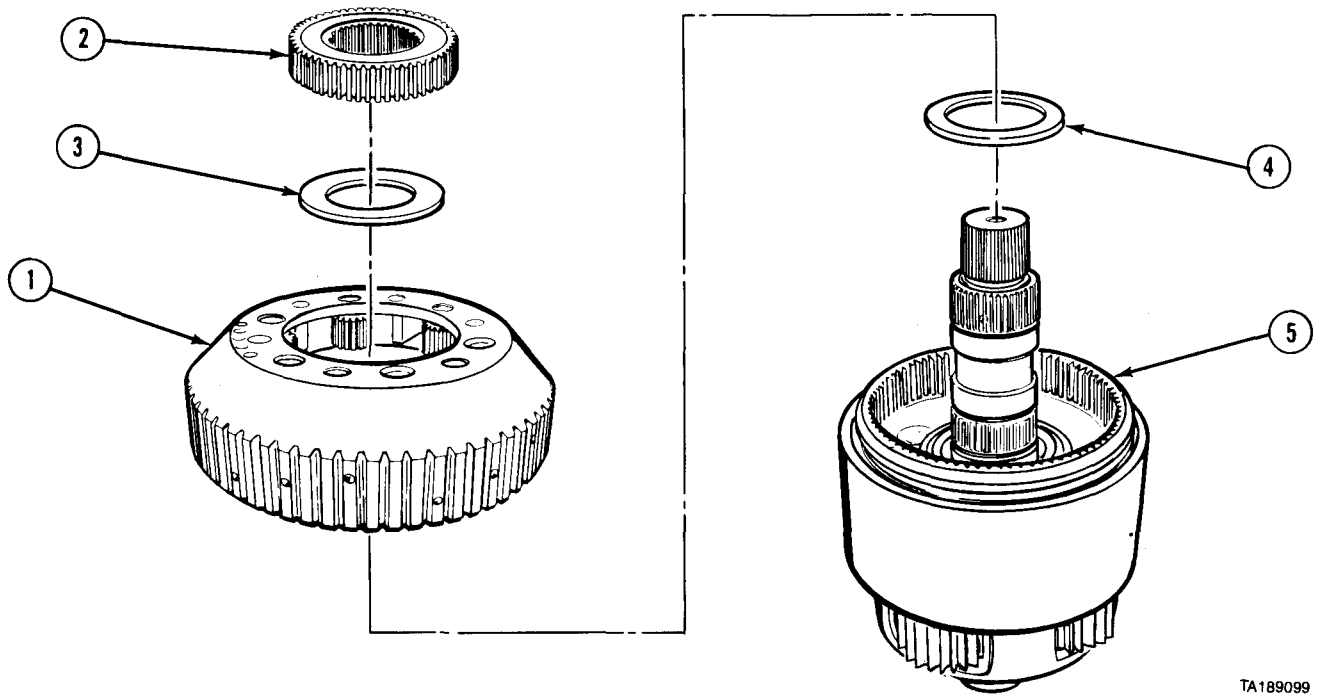

TA189099

- (1) Remove front carrier assembly (1).
- (2) Remove driven gear (2) from front carrier assembly (1).
- (3) Remove thrust washer (3) from bottom of front carrier assembly (1).
- (4) Remove thrust washer (4) from top of center carrier assembly (5).

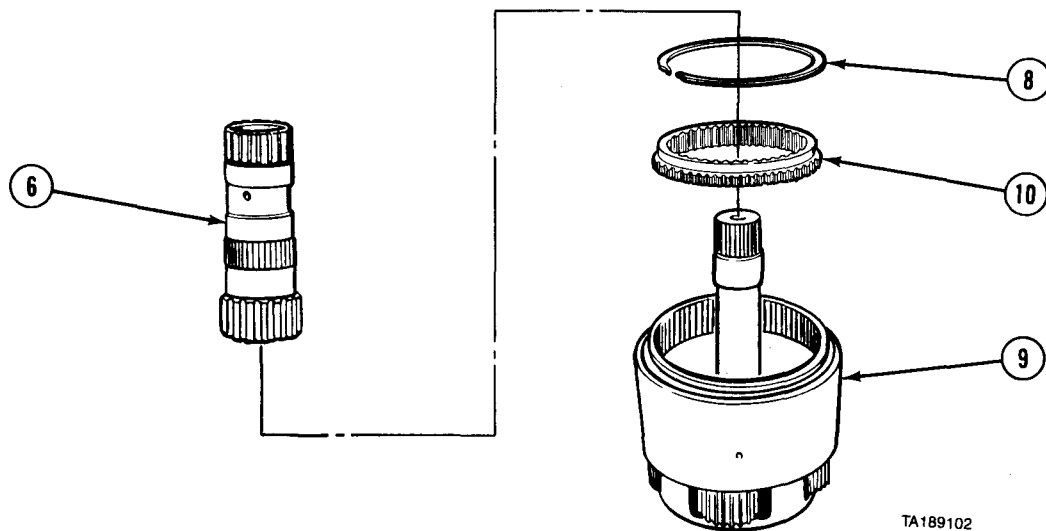

TA189102

- (5) Remove sun gear shaft (6) from main shaft (7).
- (6) Remove retaining ring (8) from transmission drum (9).
- (7) Remove spur gear (10).

7-13. GEAR UNIT AND MAIN SHAFT ASSEMBLY REMOVAL/REPAIR/INSTALLATION (CONT).

- (8) Remove center carrier assembly (5) from transmission drum (9).
- (9) Remove thrust washer (11) from base of main shaft (7).

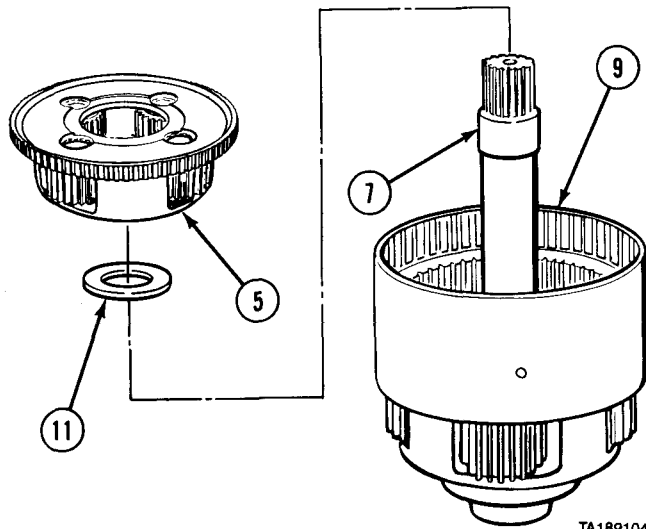

TA189104

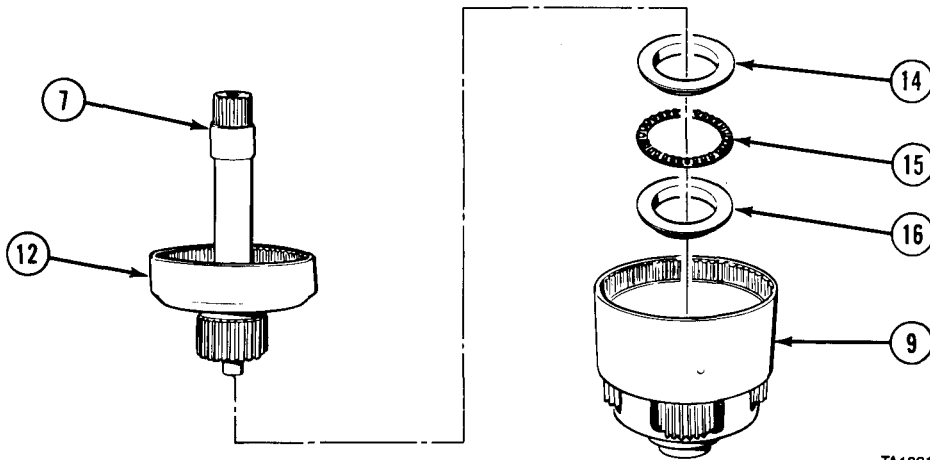

TA189106

- (10) Remove main shaft (7) from transmission drum (9) with internal gear (12) and spur gear shaft (13) attached.
- (11) Remove bearing race (14), bearing (15), and bearing race (16).
- (12) Remove spiral locking ring (17).
- (13) Remove internal gear (12) from main shaft (7).
- (14) Remove lube orifice plug (18) from main shaft (7).

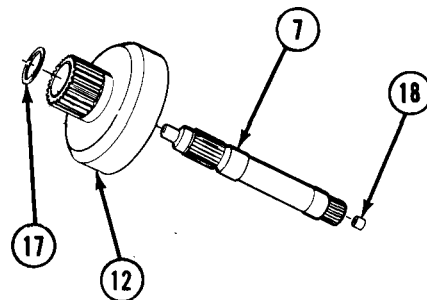

TA189107

Transmission Maintenance Instructions (Cont)

- (15) Remove retaining ring (19), internal gear (12), and spur gear shaft (13).
- (16) Position transmission drum (9) so rear carrier assembly (20) is up.
- (17) Remove retaining ring (21) and separate rear carrier assembly (20) from transmission drum (9).
- (18) Remove bearing (22) from rear carrier assembly (20).

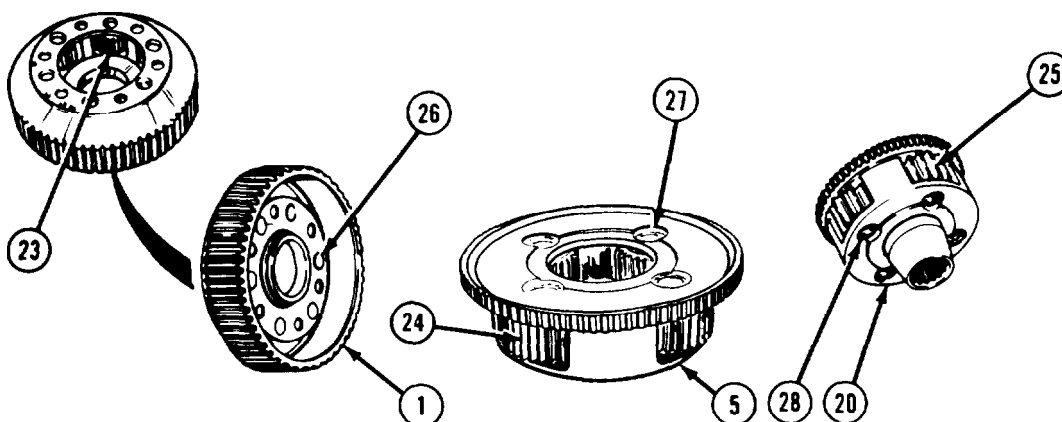
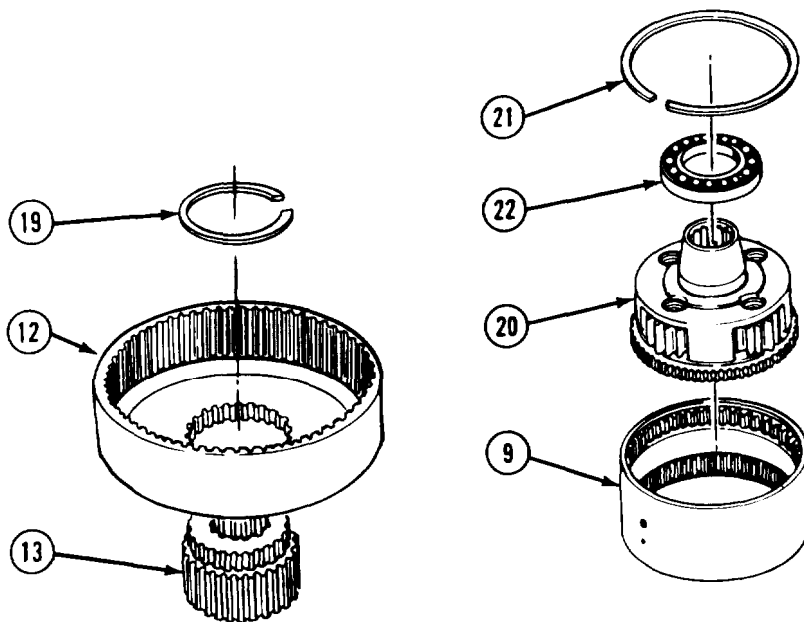

- (19) Check end play between pinion gears (23, 24, and 25) and carriers (1, 5, and 20). End play must be between 0.008 and 0.031 in. (0.203 and 0.787 mm).

CAUTION

Do not drill into the carrier assemblies.

NOTE

If end play between piston gears and carriers is other than 0.008 and 0.031 in. (0.203 and 0.787 mm), perform steps (20) through (25).

- (20) Drill away staked rear ends of front carrier assembly (1) pinion pins (26) using a 15/16 in. (23.8 mm) bit.
- (21) Drill away staked front ends of center carrier assembly (5) pinion pins (27) using a 15/16 in. (23.8 mm) bit.
- (22) Drill away staked ends of rear carrier assembly (20) pinion pins (28) using a 1-3/16 in. (30.2 mm) bit.

Transmission Maintenance Instructions (Cont)

7-13. GEAR UNIT AND MAIN SHAFT ASSEMBLY REMOVAL/REPAIR/INSTALLATION (CONT).

NOTE

Front, center, and rear carrier assemblies are disassembled the same way. Disassembly of center carrier is shown.

- (23) Position center carrier assembly (5) with drilled ends of pinion pins (27) upward in press.
- (24) Press pinion pins (27) from center carrier assembly (5).

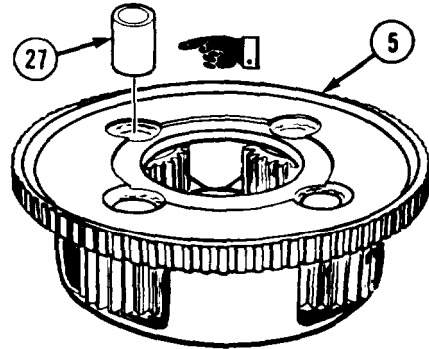

- (25) Remove pinions (24), roller bearings (29), steel thrust washers (30), and bronze thrust washers (31) from center carrier assembly (5).

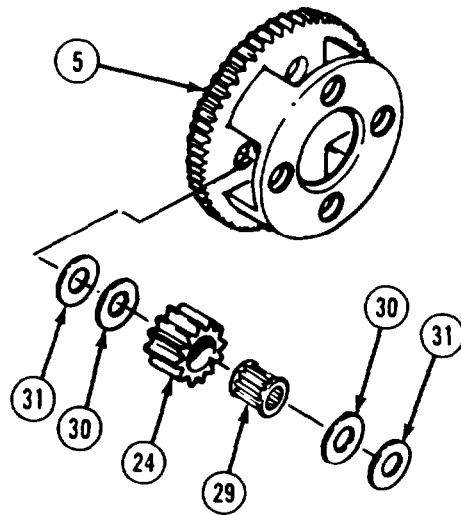

C. Cleaning/Inspection.

WARNING

Adhesives, solvents, and sealing compounds can burn easily, can give off harmful vapors, and are harmful to skin and clothing. To avoid injury or death, keep away from open fire and use in well-ventilated area. If adhesive, solvent, or sealing compound gets on skin or clothing, wash immediately with soap and water.

- (1) Clean all metal parts with drycleaning solvent.

NOTE

All planetary gears in a carrier assembly are replaced as a set.

- (2) Inspect parts for damage. Replace damaged parts.
- (3) Measure thickness of thrust washers. Thickness must be no less than 0.091 in. (2.31 mm)

NOTE

Bearing surface measurement will be used in paragraph 7-16 to find output shaft bushing clearance.

- (4) Measure and note diameter of bearing surface (1) of main shaft (2).
- (5) Measure diameter of front carrier bearing surface (3).
- (6) Measure inside diameter of bushing (4).
- (7) If bushing (4) to front carrier bearing surface (3) clearance is greater than 0.0072 in. (0.15 mm), replace bushing.
- (8) Measure diameter of bearing surfaces (2 and 5) on main shaft.
- (9) Measure inside diameter of bushings (6 and 7) in sun gear shaft (8).
- (10) If clearance between bushings (6 and 7) and bearing surfaces (2 and 5) is more than 0.0064 in. (0.16 mm), remove bushings.

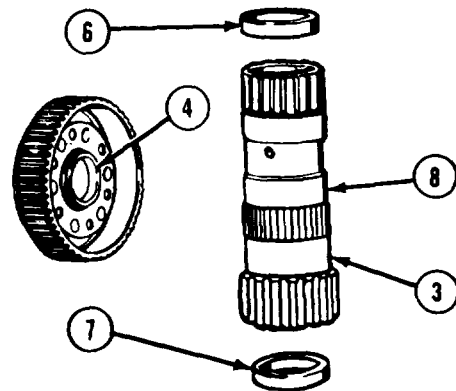
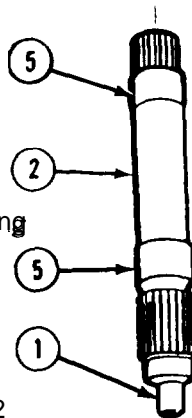

Transmission Maintenance Instructions (Cont)

d. Assembly.

NOTE

Front, center, and rear carrier assemblies are assembled the same way. Assembly of center carrier is shown.

- (1) Lubricate roller bearings (1), bronze thrust washers (2), and steel thrust washers (3) with lubricating oil.

NOTE

Front and rear carrier assemblies are positioned in press for assembly with rear end up and center assembly is positioned with front end up.

- (2) Position center carrier assembly (4) in press with front end up.
- (3) Position roller bearings (1) in pinion (5).
- (4) Position steel thrust washer (3) at each end of pinion (5).
- (5) Position bronze thrust washer (2) on each steel thrust washer (3).
- (6) Position pinion (5) in center carrier assembly (4).

- (7) Using press, install pinion pin (6) in carrier until both ends of pinion pin are equal.
- (8) Remove center carrier assembly (4) from press.

NOTE

Pinion must rotate freely and have 0.008 in. (0.203 mm) minimum end play after staking the pins.

- (9) Stake both ends of pinion pins (6) in four places.

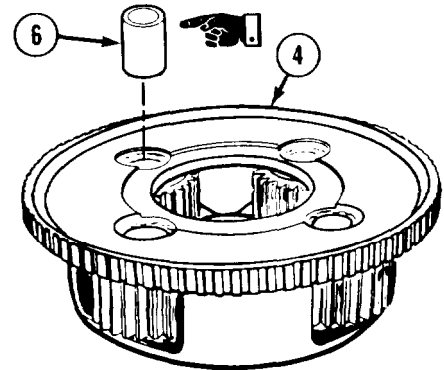
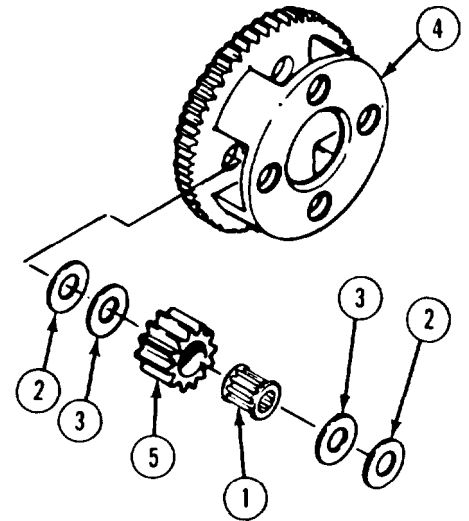

Transmission Maintenance Instructions (Cont)

7-13. GEAR UNIT AND MAIN SHAFT ASSEMBLY REMOVAL/REPAIR/INSTALLATION (CONT).

WARNING

Adhesives, solvents, and sealing compounds can burn easily, can give off harmful vapors, and are harmful to skin and clothing. To avoid injury or death, keep away from open fire and use in well-ventilated area. If adhesive, solvent, or sealing compound gets on skin or clothing, wash immediately with soap and water.

NOTE

Teflon impregnated bushings are fully interchangeable and replace previous bushings. Teflon impregnated bushings are identified by a grey color on the inside diameter. Previous bushings were bronze in color.

- (10) Apply lubricating sealing compound to bushings (7 and 8).

CAUTION

When installing Teflon impregnated bushings, use care not to damage coating on inside diameter.

- (11) Position bushing (7) at bore of small end of sun gear shaft (9). Aline bushing so interlock split is more than 45 degrees from swaging hole in sun gear shaft.

NOTE

When installing Teflon impregnated bushings, do step (11.1) and continue with step (12).

- (11.1) Using bushing installer tool (J25458-3), press in bushing (7) until flush with sun gear shaft (9).
- (12) Using end of bushing installer tool (J24201), marked 0.360, press in bushing (7) to 0.360 in. (9.14 mm) below end surface into small outside diameter of shaft (9).
- (13) Position bushing (8) at bore of large end of sun gear shaft (9). Aline bushing so interlock split is more than 45 degrees from swaging hole in sun gear shaft.

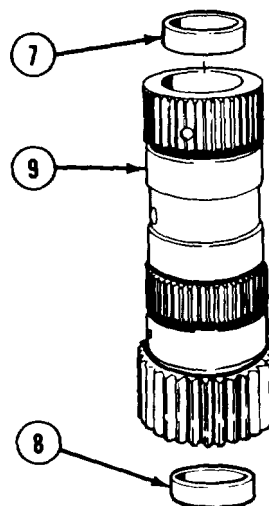

NOTE

When installing Teflon impregnated bushings, do step (13.1) and continue with step (13.2).

- (13.1) Using bushing installer tool (J25458-3), press in bushing (8) until flush with sun gear shaft (9).
- (13.2) Using end of bushing installer tool (J24201), marked 0.260, press in bushing (8) to 0.260 in. (6.60 mm) below end surface into the large outside diameter end of shaft.

Transmission Maintenance Instructions (Cont)

CAUTION

When swaging bushing at small end of sun gear shaft, the collar supplied with swaging tool, must be used or damage to shaft may result. Collar is not required to swage bushing at larger end.

- (14) Using swaging tool, push both bushings in swaging holes of sun gear shaft assembly (9).

NOTE

Teflon impregnated bushings do not require machining after installation. Skip steps (15) through (21) for Teflon impregnated bushings.

- (15) Clamp holding fixture in vise. Set sun gear shaft (9) in holding fixture with small end up. Position sun gear bushing reamer and pilot tool (J28489-1).

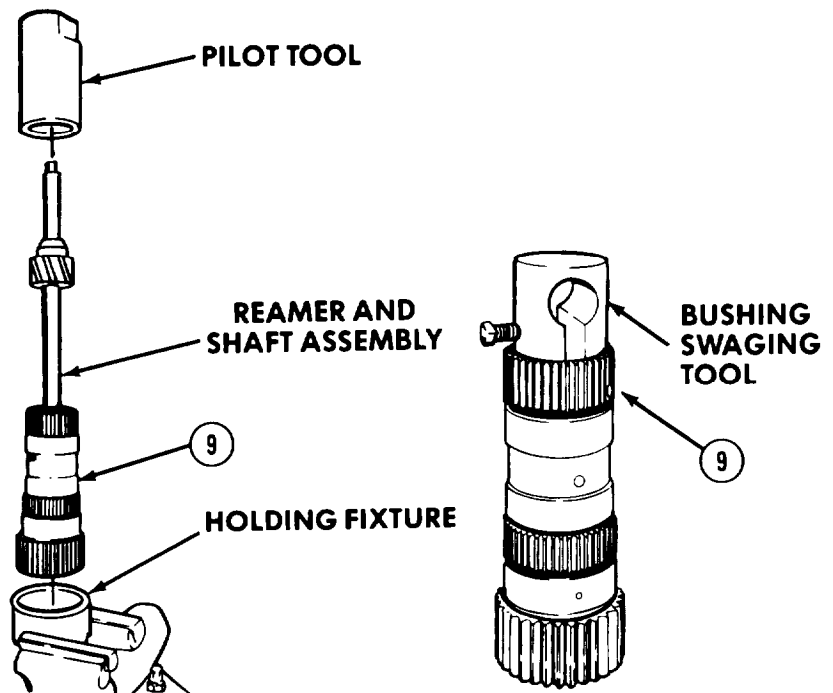

CAUTION

Keep reamer rotating at full drill speed when pulling back through bushing. If reamer is not rotating at full drill speed, bushing could be damaged.

- (16) Using 1/2-in. (13 mm) electric drill, machine bushing at approximately 75 to 150 rpm while adding oil through either hole on top of pilot tool.
- (17) Clamp pilot tool in vise. Insert bushing pilot tool in small end of sun gear shaft (9) and hold with locking pin. Position bushing pilot tool in pilot tool, and position reamer and shaft assembly in sun gear shaft.

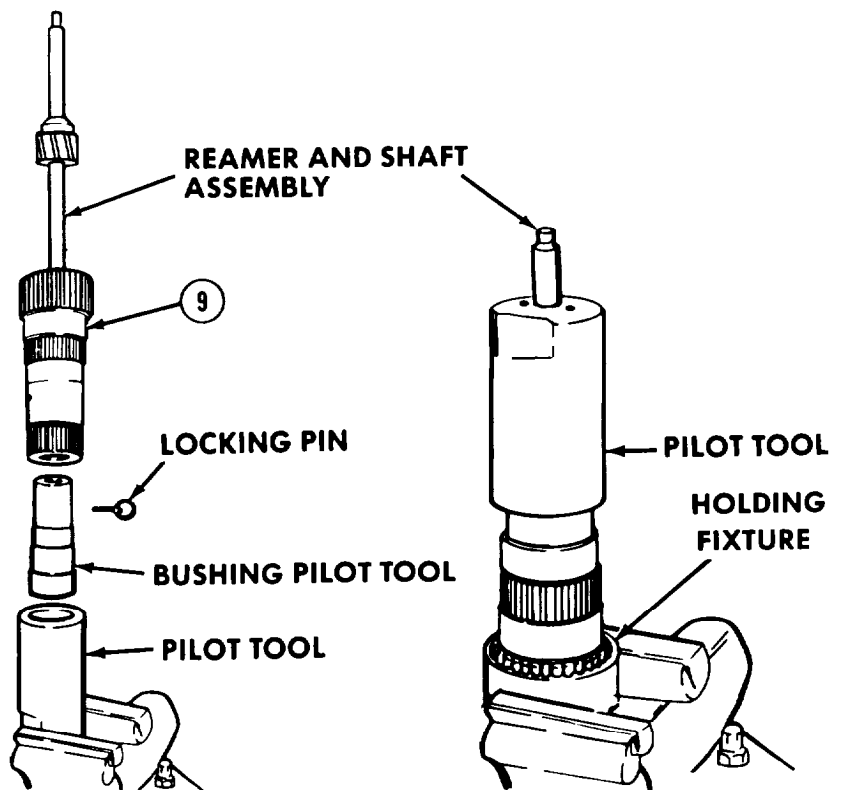

Transmission Maintenance Instructions (Cont)

(18) Engage shaft of reamer and shaft assembly with pilot tool.

CAUTION

Keep reamer rotating at full drill speed when pulling back through bushing. If reamer is not rotating at full drill speed, bushing could be damaged.

- (19) Using 1/2-in. (13 mm) electric drill, machine bushing at approximately 75 to 150 rpm while adding lubricating oil in bore at sides of sun gear shaft (9).
- (20) Check inner diameter of bushings for runout. Runout must not exceed 0.002 in. (0.05 mm) total indicator reading. Surface finish should be 30-microinch (0.762 micrometer).
- (21) Thoroughly clean sun gear shaft (9) of chips and debris.

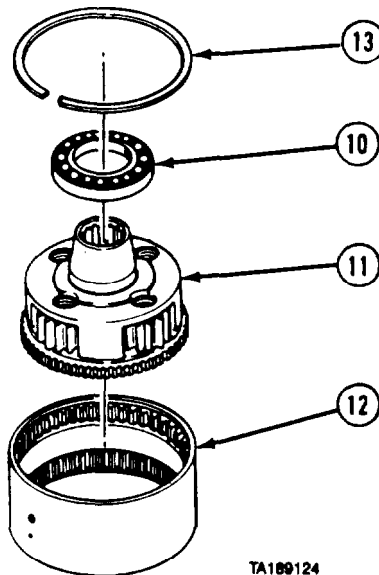
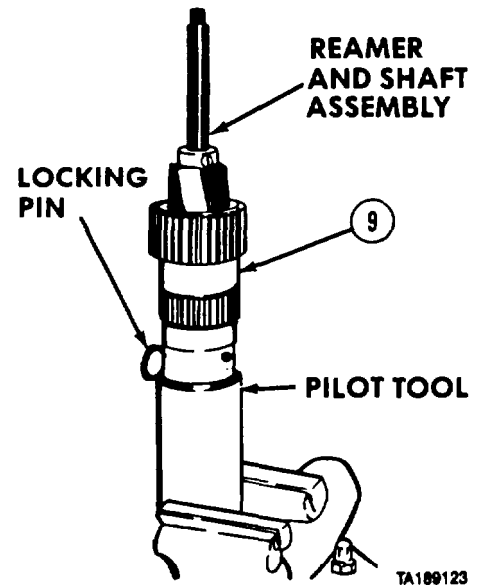

- (22) Install bearing (10) on rear carrier assembly (11).
- (23) Position rear carrier assembly (11) on transmission drum (12).
- (24) Install retaining ring (13).

Transmission Maintenance Instructions (Cont)

7-13. GEAR UNIT AND MAIN SHAFT ASSEMBLY REMOVAL/REPAIR/INSTALLATION (CONT).

- (25) Install internal gear (14) on spur gear shaft (15).
- (26) Install retaining ring (16).

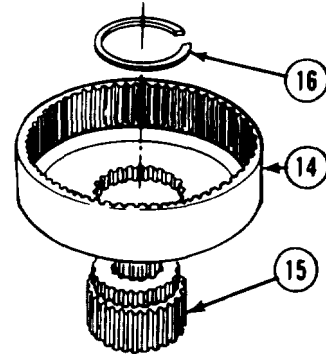

- (27) Install lube orifice plug (17) on large end of main shaft (18).
- (28) Position main shaft (18) through internal gear (14) and spur gear shaft (15).
- (29) Install spiral locking ring (19).

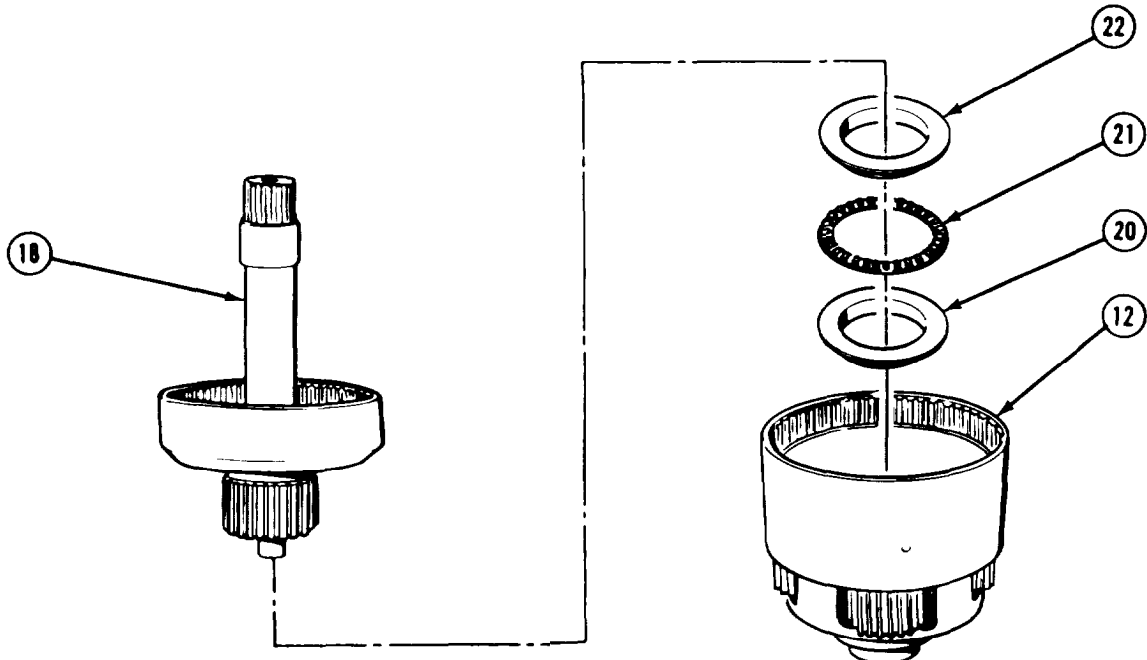
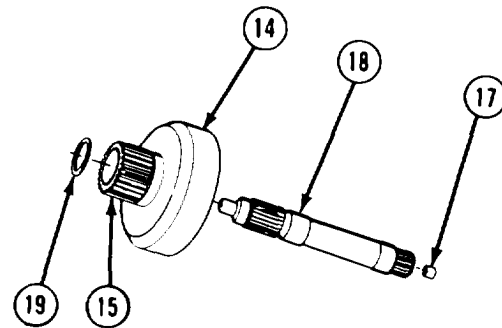

- (29.1) Apply lubrication to race (20), bearing (21), and race (22) prior to installation.
- (30) Install larger bearing race (20), bearing (21), and smaller bearing race (22) in transmission drum (12).
- (31) Install main shaft (18) in transmission drum (12).

Transmission Maintenance Instructions (Cont)

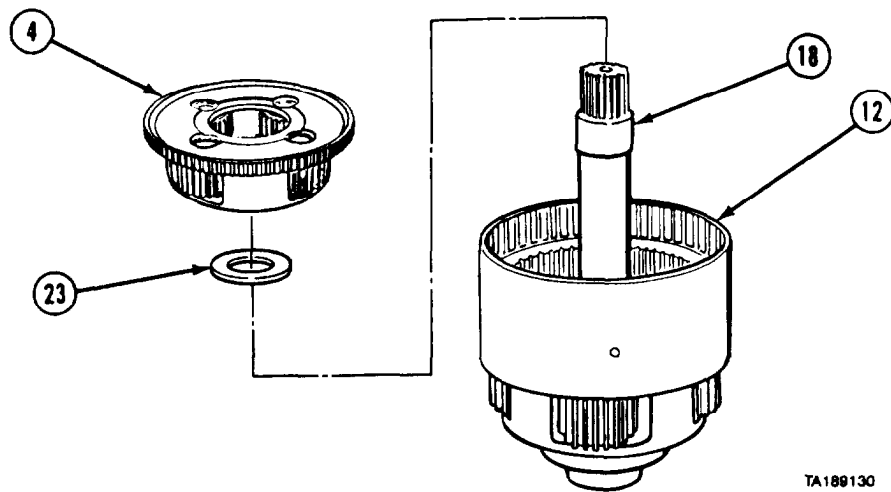

- (32) Install thrust washer (23) on base of main shaft (18).
- (33) install center carrier assembly (4) in transmission drum (12).

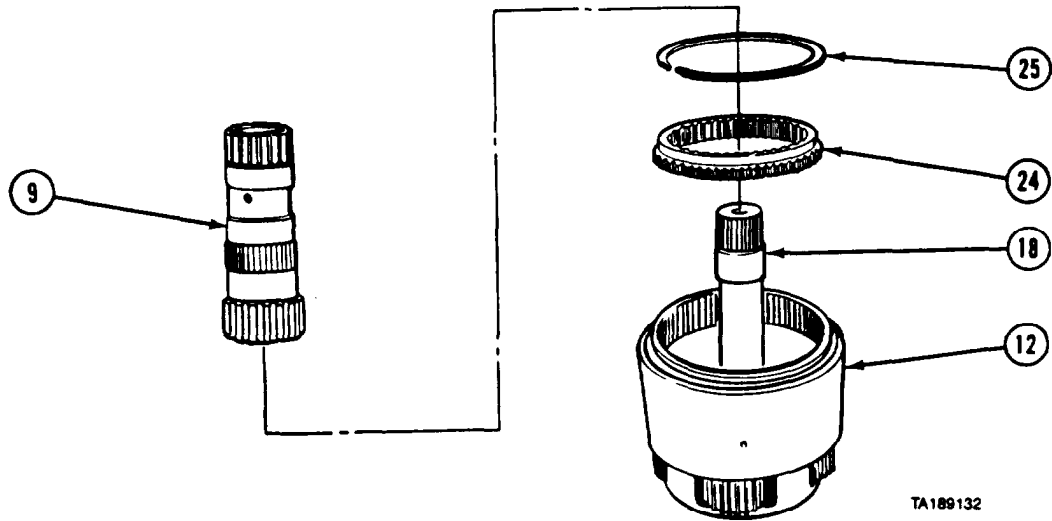

- (34) Install spur gear (24) in transmission drum (12).
- (35) Install retaining ring (25) in transmission drum (12).
- (36) Install sun gear shaft (9) on main shaft (18).

Transmission Maintenance Instructions (Cont)

7-13. GEAR UNIT AND MAIN SHAFT ASSEMBLY REMOVAL/REPAIR/INSTALLATION (CONT).

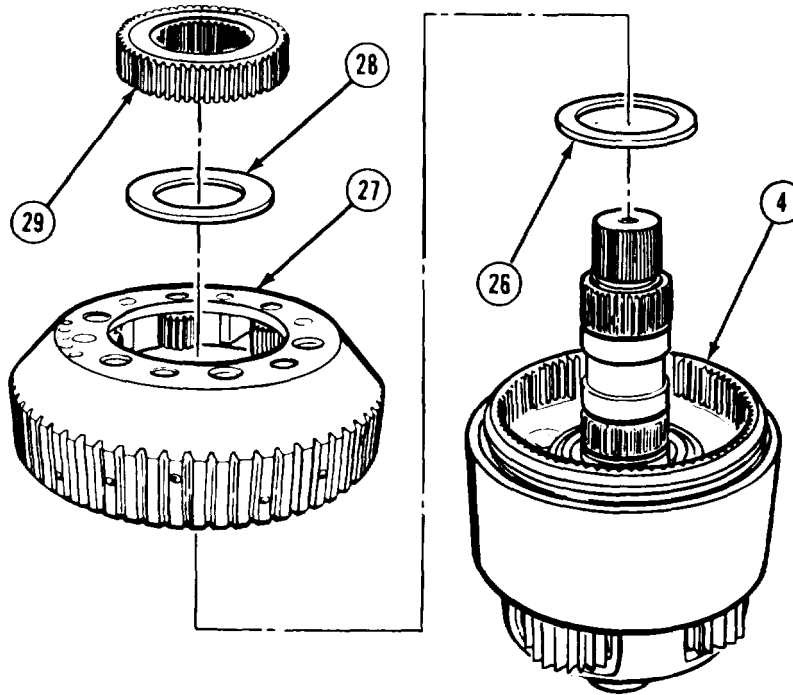

- (36.1) Lubricate thrust washer (26).
- (37) Install thrust washer (26) on center carrier assembly (4).
- (38) Install front carrier assembly (27) on center carrier assembly (4).
- (39) Install thrust washer (28) on front carrier assembly (27).
- (40) Install driven gear (29) in front carrier assembly (27).

e. Installation.

NOTE

External-tanged clutch plates (2) have two thicknesses. Insure thicker external-tanged clutch plate is next to piston. Thinner external-tanged clutch plates should be installed toward the rear of the transmission housing.

- (1) Install 12 second clutch plates (1 and 2) in transmission housing (3).
- (2) Install retaining ring (4).

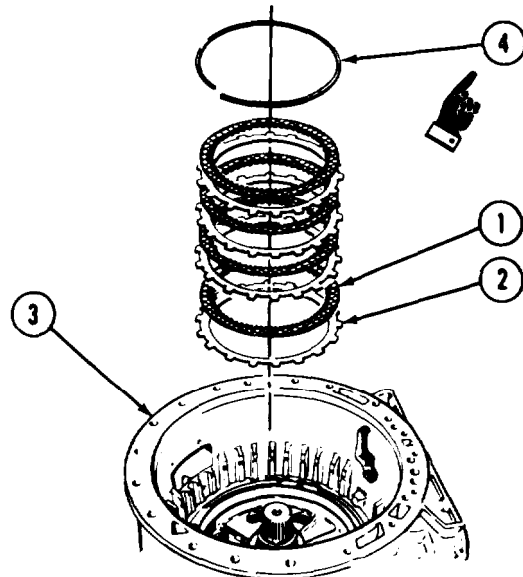

Transmission Maintenance Instructions (Cont)

- (3) Install lifting bracket to main shaft (6).
- (4) Soldier A lowers gear unit assembly (7) in transmission housing (3) while Soldier B operates lifting device.
- (5) Remove lifting bracket.

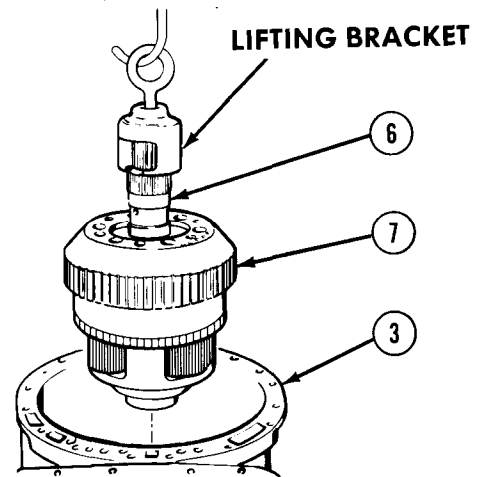

TA189136

f. Follow-on Maintenance. Install center support housing and second clutch (para 7-19).

END OF TASK

7-14. OUTPUT YOKE, DUST SHIELD, AND OIL SEAL REMOVAL/INSTALLATION.

This task covers:

- a. Removal
- b. Cleaning/Inspection
- c. Installation
- d. Follow-on Maintenance

INITIAL SETUP

Models

All

Test Equipment

None

Special Tools

- Socket, lock L883
- Transmission oil seal installer J24202-1A
- Driver handle J24202-4

Supplies

- Oil, lubricating, Item 46, Appendix C
- Solvent, dry cleaning, Item 57, Appendix C

Personnel Required

MOS 63W, Wheel vehicle repairer

References

None

Equipment Condition

<i>TM or Para</i>	<i>Condition Description</i>
TM 9-2320-279-20	Propeller shaft removed.

Special Environmental Conditions

None

General Safety Instructions

None

Level of Maintenance

Direct Support

7-14. OUTPUT YOKE, DUST SHIELD, AND OIL SEAL REMOVAL/INSTALLATION (CONT).

a. Removal.

NOTE

Torque value must be measured after loosening nut from output yoke. It must take a minimum of 300 lb-in. (33.90 N·m) to turn nut.

- (1) Remove retainer nut (1) from output shaft (2) with lock socket.
- (2) Remove output yoke (3) from output shaft (2).
- (3) Scribe one flat side of nut (1).
- (4) Remove dust shield (4) from rear cover (5).
- (5) Remove oil seal (6) from rear cover (5).

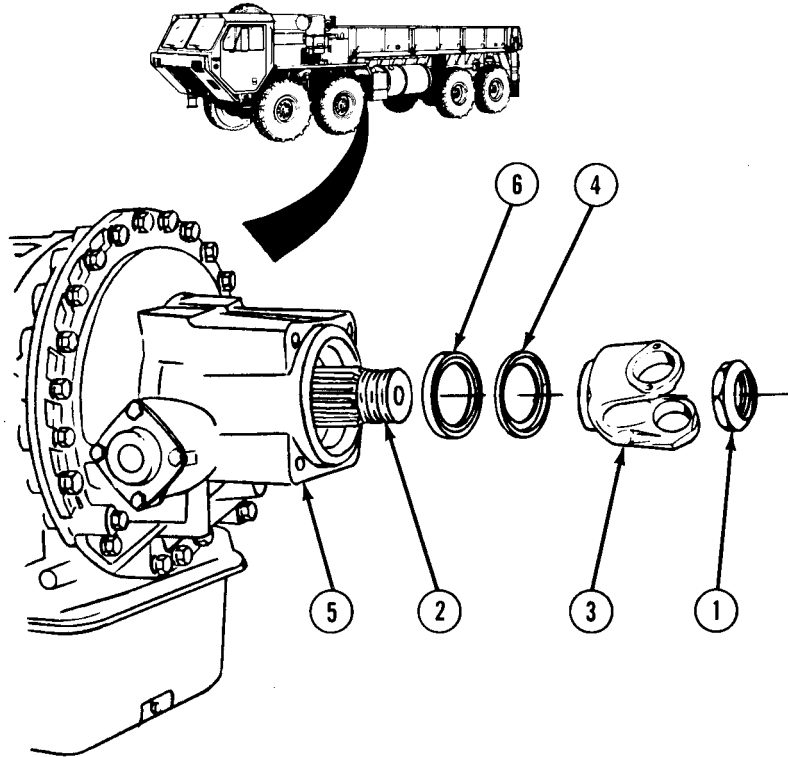

TA188519

b. Cleaning/Inspection.

WARNING

Adhesives, solvents, and sealing compounds can burn easily, can give off harmful vapors, and are harmful to skin and clothing. To avoid injury or death, keep away from open fire and use in well-ventilated area. If adhesive, solvent, or sealing compound gets on skin or clothing, wash immediately with soap and water.

- (1) Clean all metal parts with dry cleaning solvent.

WARNING

Compressed air used for cleaning purposes will not exceed 30 psi (207 kPa). Use only with effective chip guarding and personal protective equipment, goggles, shield, and gloves.

- (2) Dry all parts with compressed air.
- (3) Inspect all parts for damage.
- (4) Replace damaged parts.

Transmission Maintenance Instructions (Cont)

c. Installation.

- (1) Using oil seal installer, install oil seal (6) with seal lip facing rear cover (5).
- (2) Install dust shield (4) in rear cover (5), flat side first, so rear edge of shield is flush with surface of rear cover.
- (3) Install output yoke (3) on output shaft (2).
- (4) Coat threads of output shaft (2) and retainer nut (1) with lubricating oil.
- (5) Install retainer nut (1) on output shaft (2). Tighten nut to 600 to 800 lb-ft (813 to 1085 N•m) with lock socket.

d. Follow-on Maintenance. Install propeller shaft (TM 9-2320-279-20).

END OF TASK

Section VII. CLUTCH ASSEMBLIES

7-15. FORWARD CLUTCH ASSEMBLY REMOVAL/REPAIR/INSTALLATION		
This task covers:		
a. Removal	d. Assembly	
b. Disassembly	e. Installation	
c. Cleaning/Inspection	f. Follow-on Maintenance	
INITIAL SETUP		
<i>Models</i> All	<i>Personnel Required</i> MOS 63W, Wheel vehicle repairer (2)	
<i>Test Equipment</i> None	<i>References</i> None	
<i>Special Tools</i> Clutch spring compressor J24204-3 Collector ring installer and staking set J24200 Forward clutch piston inner seal protector J24216-01 PTO gear removal fixture J26899 Fourth clutch alinement fixture J24221 Forward clutch lifting bracket J33079-1	<i>Equipment Condition</i>	
	<i>TM or Para</i> Para 7-20	<i>Condition Description</i> Control valve body removed.
	Para 7-9	Torque converter housing removed.
	<i>Special Environmental Conditions</i> None	
<i>Fabricated Tools</i> Shim stock, Item 2, Appendix B	<i>General Safety Instructions</i> None	
<i>Supplies</i> Oil, lubricating, Item 45, Appendix C Oil, lubricating, Item 46, Appendix C Solvent, drycleaning, Item 57, Appendix C Compound, retaining, Item 24, Appendix C	<i>Level of Maintenance</i> General Support	

Transmission Maintenance Instructions (Cont)

7-15. FORWARD CLUTCH ASSEMBLY REMOVAL/REPAIR/INSTALLATION (CONT).

a. *Removal.*

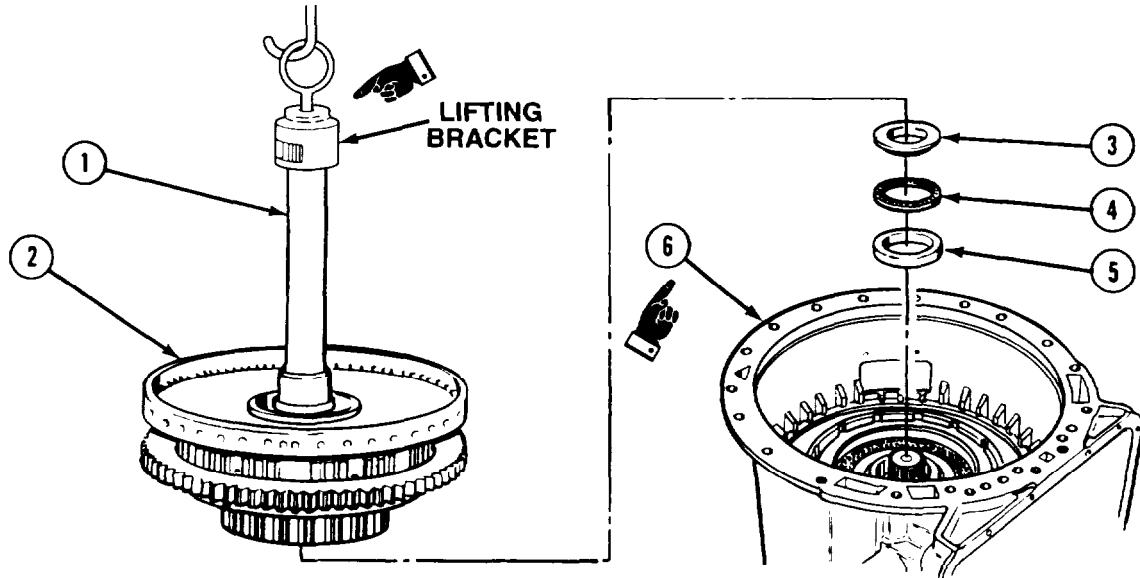

- (1) Install lifting bracket to turbine shaft (1) and secure lifting device to lifting bracket.
- (2) Soldier A removes forward clutch assembly (2) from transmission housing (6) while Soldier B operates lifting device.
- (3) Hold turbine shaft (1) and remove forward clutch assembly (2), outer race (3), roller bearing (4), and inner race (5).
- (4) Place forward clutch assembly (2) in clean area,
- (5) Remove lifting bracket.

b. **Disassembly.**

- (1) Remove seal rings (1 and 2) from turbine shaft (3).
- (2) Place collector ring installer on bed of press.
- (3) Turn forward clutch assembly (4) over and install through collector ring installer and in bed of press.

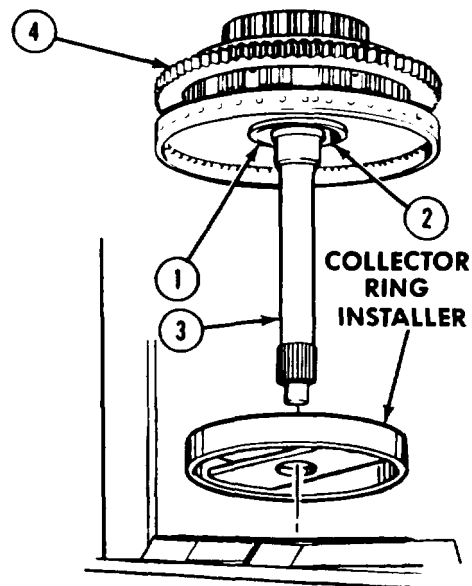

Transmission Maintenance Instructions (Cont)

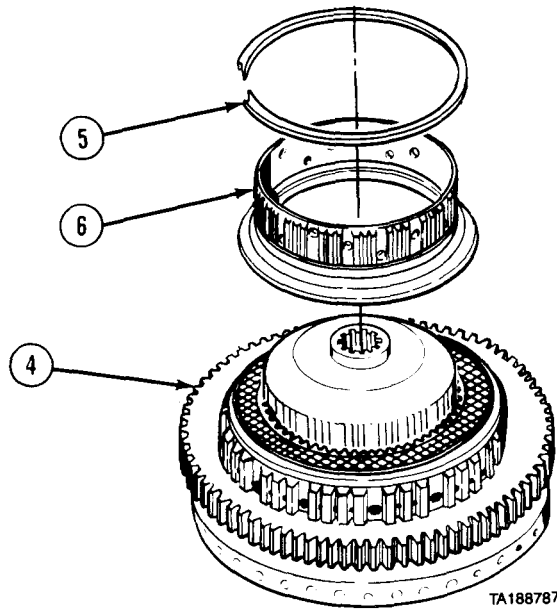

TA188787

- (4) Remove large inner retaining ring (5) holding fourth clutch driving hub (6).
- (5) Remove fourth clutch driving hub (6) from forward clutch assembly (4).

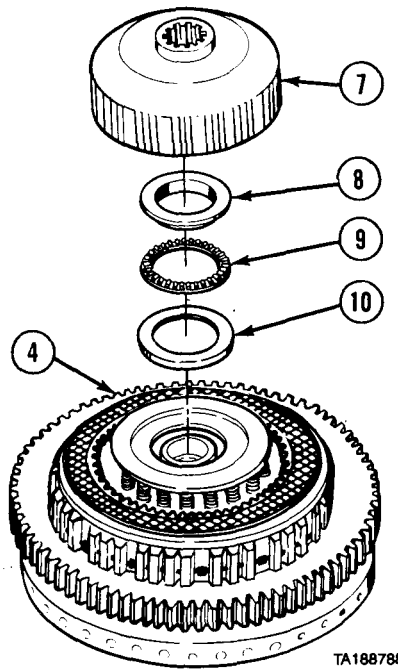

TA188788

- (6) Remove forward clutch driving hub (7), inner race (8), bearing (9), and outer race (10) from forward clutch assembly (4).

Transmission Maintenance Instructions (Cont)

7-15. FORWARD CLUTCH ASSEMBLY REMOVAL/REPAIR/INSTALLATION (CONT).

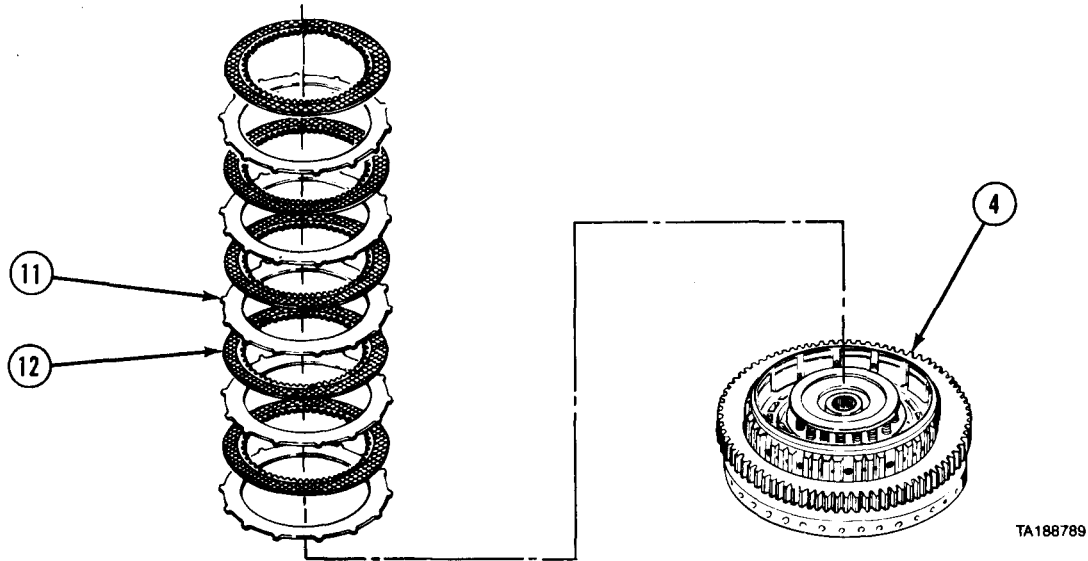

(7) Remove five steel plates (11) and five friction plates (12) from forward clutch assembly (4).

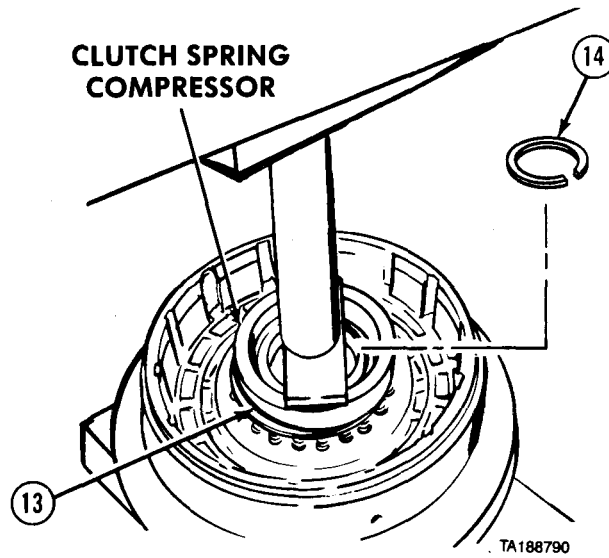

(8) Compress spring retainer (13) with clutch spring compressor. Remove retaining ring (14).
(9) Release pressure from spring retainer (13) and remove clutch spring compressor.

Transmission Maintenance Instructions (Cont)

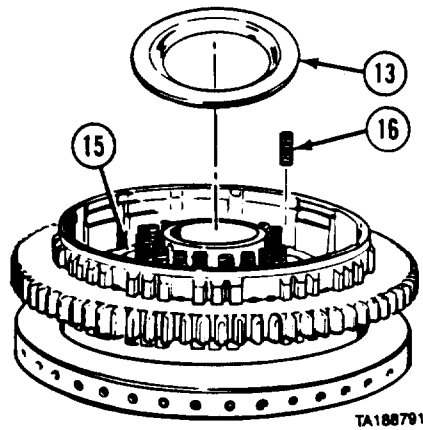

- (10) Remove spring retainer (13) from forward clutch piston (15).
- (11) Remove 20 piston return springs (16) from forward clutch piston (15).

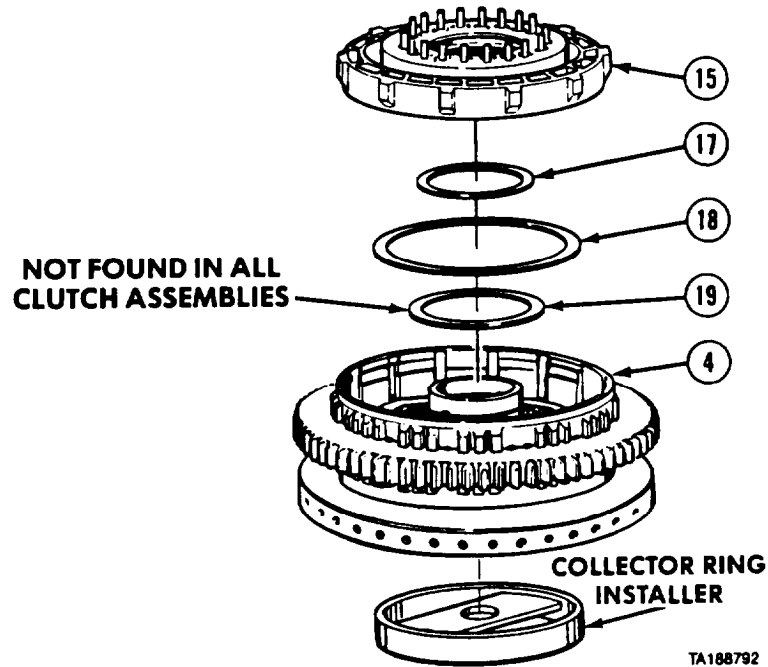

NOTE

Not all clutch assemblies will have a seal ring. If seal ring is removed, discard and do not replace during installation.

- (12) Remove forward clutch piston (15) from forward clutch assembly (4).
- (13) Remove inner seal ring (17) and outer seal ring (18) from forward clutch piston (15).
- (14) Remove seal ring (19) from inner hub in forward clutch assembly (4).
- (15) Remove forward clutch assembly (4) and collector ring installer from press.

Transmission Maintenance Instructions (Cont)

7-15. FORWARD CLUTCH ASSEMBLY REMOVAL/REPAIR/INSTALLATION (CONT).

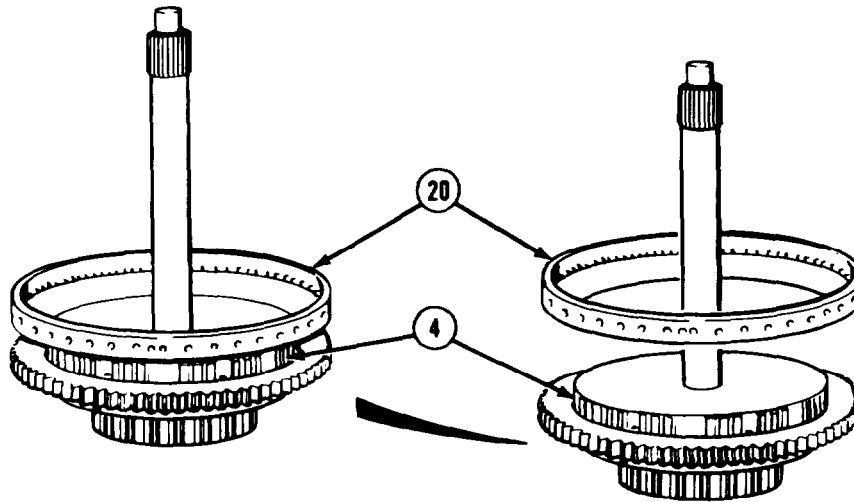

CAUTION

Do not damage pitot collector ring during removal.

(16) Pry pitot collector ring (20) loose from forward clutch assembly (4).

- (17) Place PTO gear removal fixture in press.
- (18) Install forward clutch assembly (4) on PTO gear removal fixture.
- (19) Install PTO removal tool in forward clutch assembly (4).

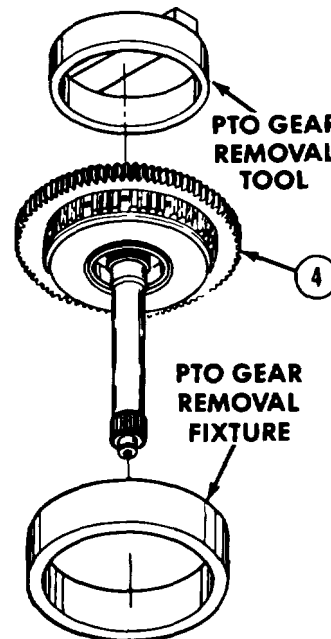

Transmission Maintenance Instructions (Cont)

- (20) Find gap in retaining ring (21).
- (21) Install shim stock between retaining ring (21) and teeth of PTO gear (22). Push retaining ring in forward clutch assembly (4). Put shim stock every 3 in. (76 mm) around forward clutch assembly.
- (22) Press forward clutch assembly (4) out of PTO gear (22).
- (23) Remove PTO gear (22), forward clutch assembly (4), PTO gear removal tool, and PTO gear removal fixture from press.

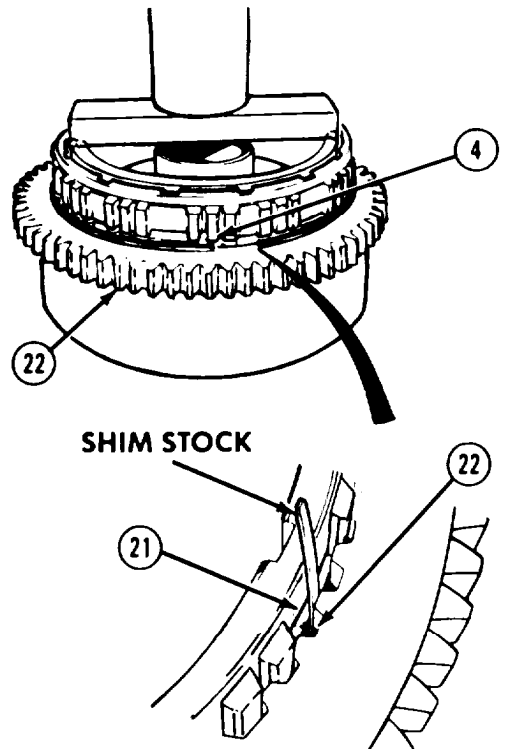

c. Cleaning/Inspection.

WARNING

Adhesives, solvents, and sealing compounds can burn easily, can give off harmful vapors, and are harmful to skin and clothing. To avoid injury or death, keep away from open fire and use in well-ventilated area. If adhesive, solvent, or sealing compound gets on skin or clothing, wash immediately with soap and water.

- (1) Clean all metal parts with drycleaning solvent and inspect for damage. Replace damaged parts.
- (2) Turbine shaft is pressed in forward clutch housing and should be tight. Replace forward clutch housing if there is any up and down movement.
- (3) Replace all 20 piston release springs if any three springs do not meet the following load-height requirements:
 - (a) Length without load: 1.25 in. (31.8 mm)
 - (b) Length under load: 0.88 in. (22.4 mm) with load of 17.9 to 18.9 lb (79.6 to 84.1 N).

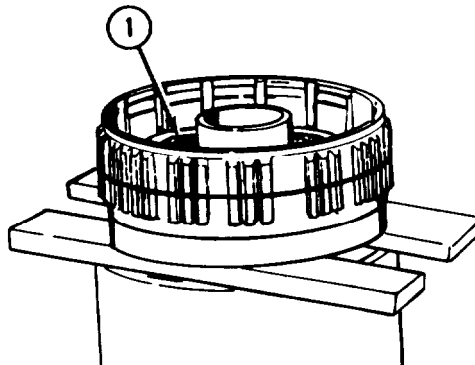

- (4) Clean ball pockets (1) with drycleaning solvent if there is leakage at bottom side of housing or if balls do not move freely of their own weight.

WARNING

Compressed air used for cleaning purposes will not exceed 30 psi (207 kPa). Use only with effective chip guarding and personal protective equipment, goggles, shield, and gloves.

- (5) Dry pockets with compressed air.
- (6) Apply lubricating oil around area of ball pockets (1).

Transmission Maintenance Instructions (Cont)

7-15. FORWARD CLUTCH ASSEMBLY REMOVAL/REPAIR/INSTALLATION (CONT).

d. Assembly.

NOTE

Coat all parts with lubricating oil before installation.

- (1) Place collector ring installer in press.
- (2) Install forward clutch assembly (1) on collector ring installer.
- (3) Install retaining ring (2) in groove (3) on outside of forward clutch assembly (1).

WARNING

Wear heat-resistant gloves to prevent burning hands when handling hot PTO gear.

- (4) Heat PTO gear (4) in oven or oil bath to 350° to 375° F (1770 to 191%).

NOTE

Install PTO gear with beveled side of inner teeth down.

- (5) Carefully place PTO gear (4) on forward clutch assembly (1).

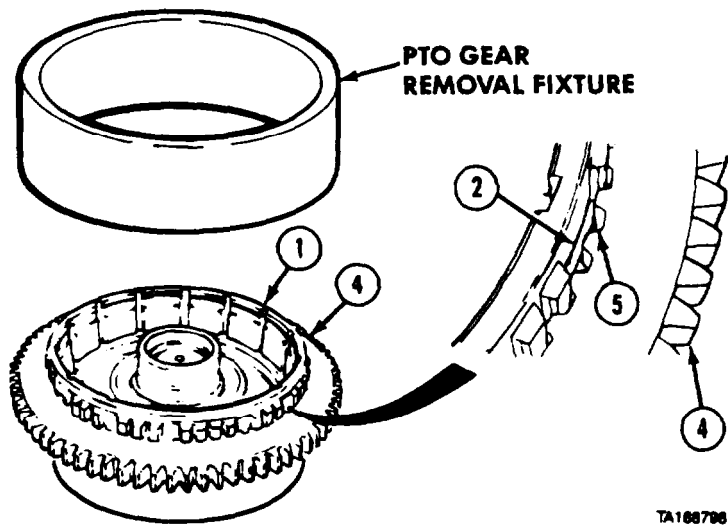
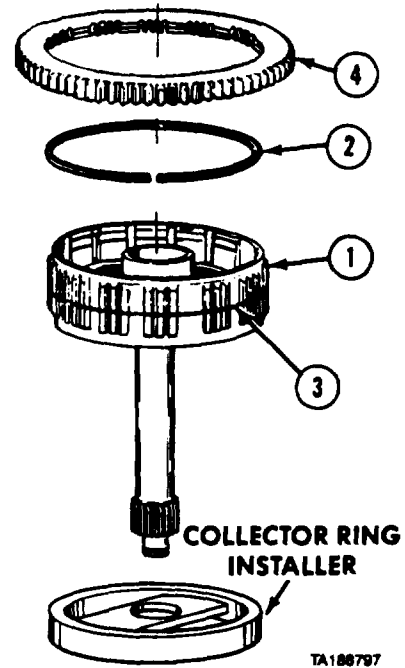

- (6) Install PTO gear removal fixture on forward clutch assembly (1).
- (7) Press PTO gear (4) on forward clutch assembly (1) until retaining ring (2) expands in groove (5) inside PTO gear.

Transmission Maintenance Instructions (Cont)

- (8) Remove forward clutch assembly (1) and collector ring installer from press.
- (9) Coat collar of oil collector ring (6) with retaining compound and place on forward clutch assembly (1).
- (10) Install collector ring installer on oil collector ring (6) and install oil collector ring.
- (11) Remove collector ring installer.

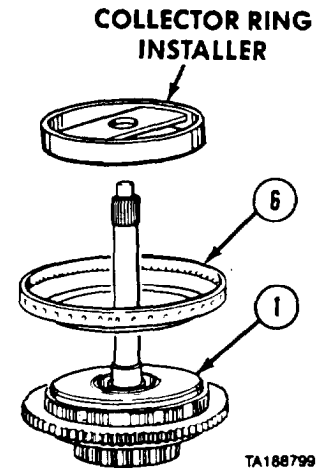

- (12) Using staking tool, Soldier A bends edge of oil collector ring (6) in groove in forward clutch assembly (1) while Soldier B supports forward clutch assembly on edge, making sure oil collector ring does not touch work surface.

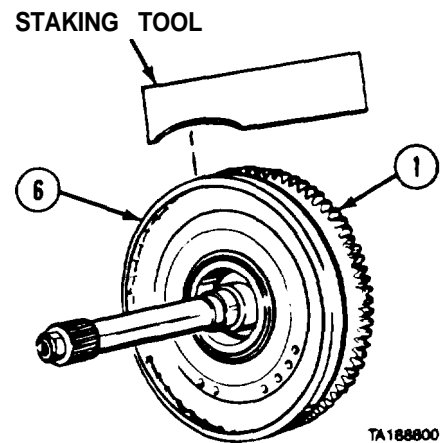

- (13) Look at bottom of forward clutch piston (7) and note whether forward clutch piston is labeled A, B, or C.

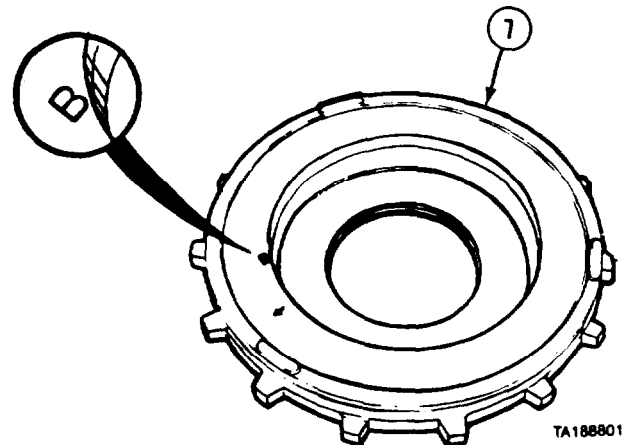

Transmission Maintenance Instructions (Cont)

7-15. FORWARD CLUTCH ASSEMBLY REMOVAL/REPAIR/INSTALLATION (CONT).

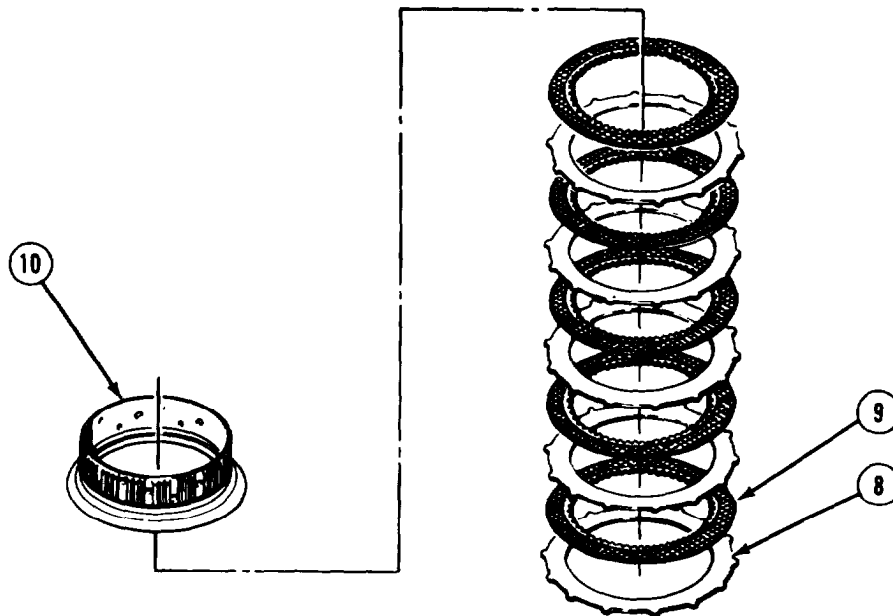

- (14) Stack 10 clutch plates (8 and 9) on flat surface of press starting with steel plate (8) and alternating with friction plate (9).
- (15) Place fourth clutch driving hub (10) on clutch plates (8 and 9).

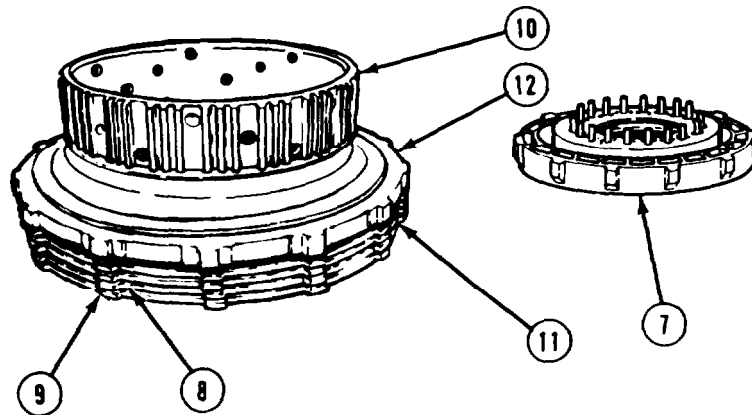

NOTE

Pressure is applied to clutch pack to steady clutch pack.

- (16) Press evenly on fourth clutch driving hub (10) with 980 to 1020 lb load.
- (17) Measure distance from base of clutch pack (11) to machined surface (12) of hub (10) to get clutch pack thickness.
- (18) If forward clutch piston (7) is an A piston, clutch pack thickness must be 1.415 to 1.442 in. (35.94 to 36.63 mm). If forward clutch piston is a B piston, clutch pack thickness must be 1.388 to 1.414 in. (35.26 to 35.92 mm). If forward clutch piston is a C piston, clutch pack thickness must be 1.361 to 1.387 in. (34.57 to 35.23 mm). Replace clutch plates (8 and 9) as needed to ensure proper clutch pack thickness.
- (19) Remove clutch pack (11) and fourth clutch driving hub (10) from press.

Transmission Maintenance Instructions (Cont)

(20) Install forward clutch assembly (1) with shaft (13) down through collector ring installer and in hydraulic press.

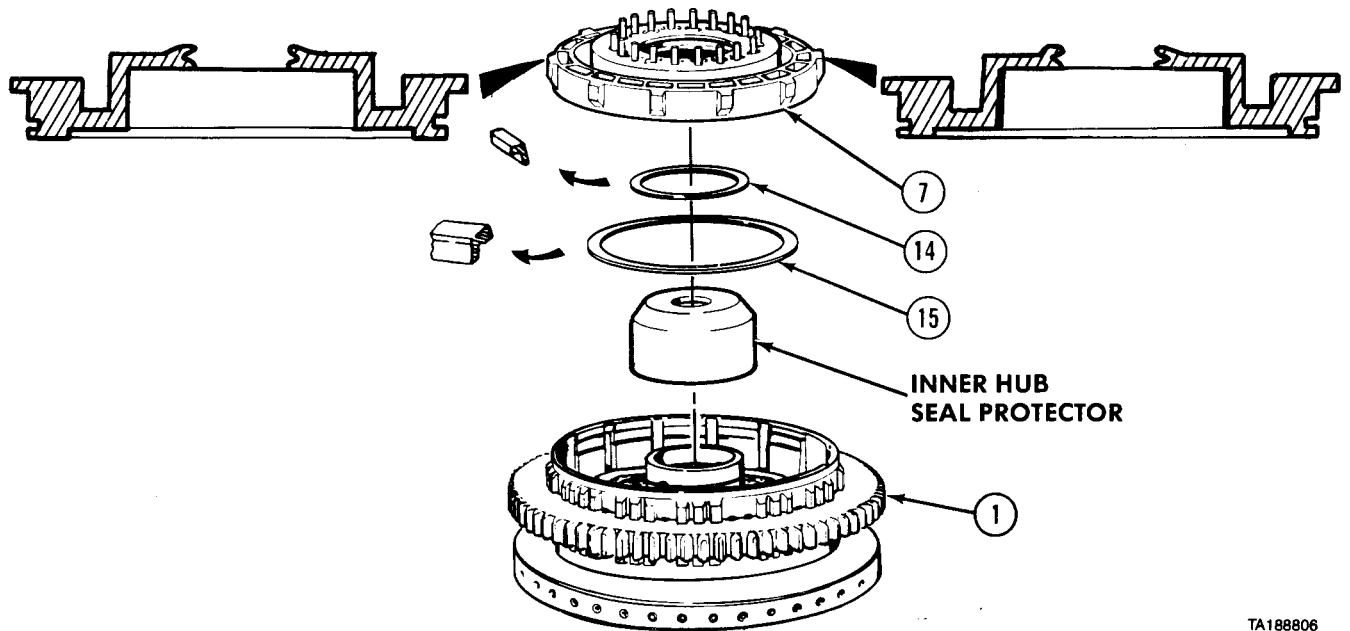
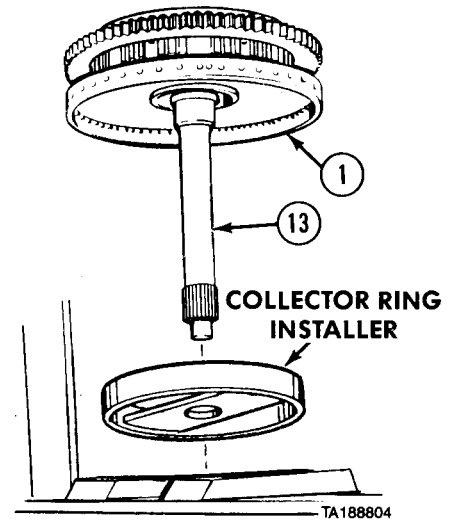

CAUTION

Do not mix old and new style pistons and housings. Equipment may be damaged.

NOTE

- There are two styles of clutch pistons and clutch assemblies. The old style clutch piston is machined smooth, new style has rough casting. The old style clutch assembly has a groove for installation of a seal ring, new style does not have a groove.
- If new housing is used, a third seal ring is used.

(21) Apply lubricating oil to two seal rings (14 and 15).

(22) Install small seal ring (14) and large seal ring (7), lips down, on forward clutch piston (7).

(23) Install inner hub seal protector over inner hub of forward clutch assembly (1).

(24) Install forward clutch piston (7) over seal protector. Carefully work piston completely down until seated.

(25) Remove inner hub seal protector.

7-15. FORWARD CLUTCH ASSEMBLY REMOVAL/REPAIR/INSTALLATION (CONT).

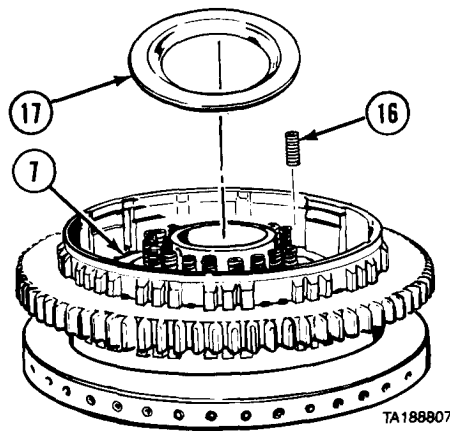

- (26) Install 20 piston release springs (16) on forward clutch piston (7).
- (27) Install piston release spring retainer (17) on piston release springs (16).

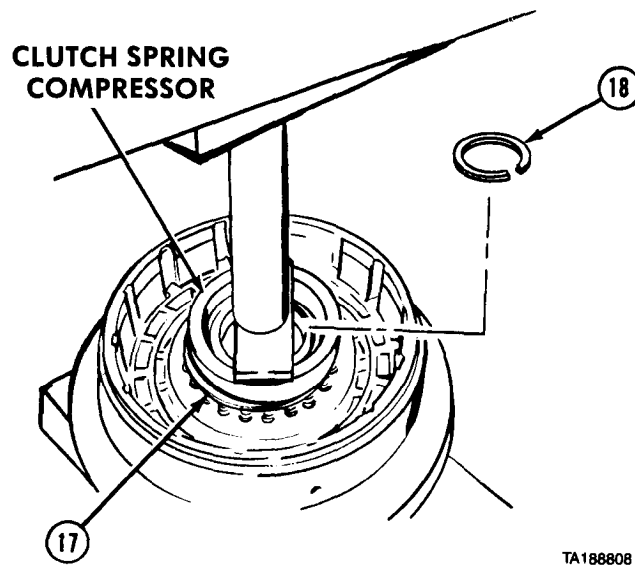

- (28) Compress spring retainer (17) with clutch spring compressor tool and press. Install retaining ring (18).
- (29) Release pressure from spring retainer (17) and remove clutch spring compressor.

Transmission Maintenance Instructions (Cont)

NOTE

Install bearing race with cupped side down.

- (30) Lubricate and install thrust bearing race (19) on small hub of forward clutch assembly (1).
- (31) Lubricate and install thrust bearing (20) on thrust bearing race (19).
- (32) Coat bearing race (21) with lubricating oil and install.
- (33) Install forward clutch drive hub (22) on forward clutch assembly (1).

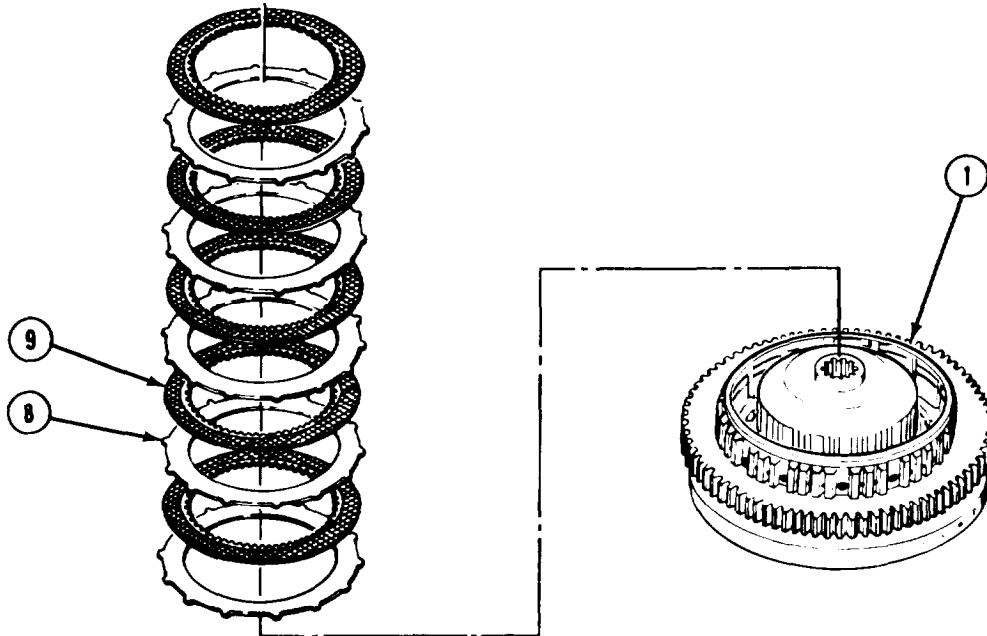
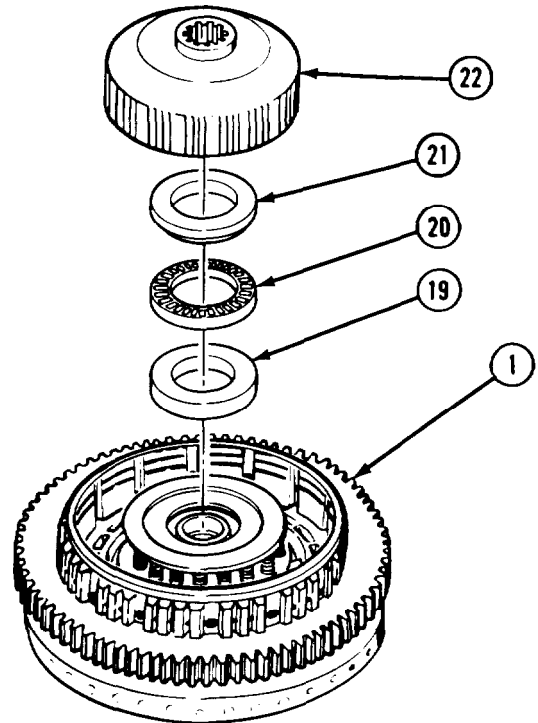

- (34) Soak five friction plates (9) in clean lubricating oil for 2 minutes.
- (35) Install 10 clutch plates (8 and 9), starting with external-tanged steel plate and alternating with internally tanged friction plate.

Transmission Maintenance Instructions (Cont)

7-15. FORWARD CLUTCH ASSEMBLY REMOVAL/REPAIR/INSTALLATION (CONT).

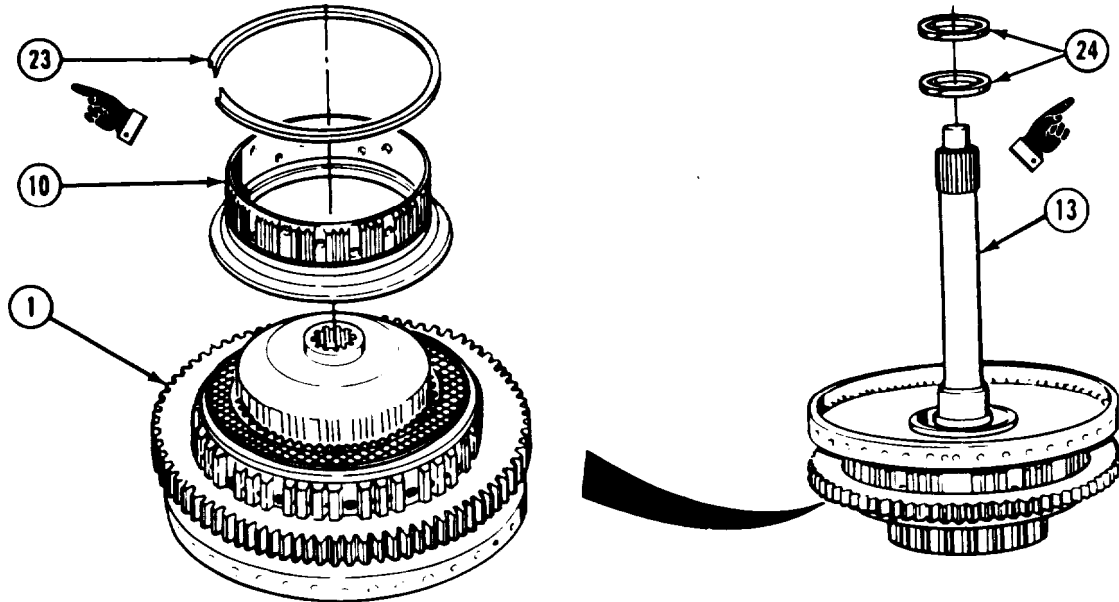

- (36) Install fourth clutch driving hub (10) on forward clutch assembly (1).
- (37) Install large inner retaining ring (23) on fourth clutch driving hub (10).
- (38) Lubricate and install two seal rings (24) on turbine shaft (13).

e. Installation.

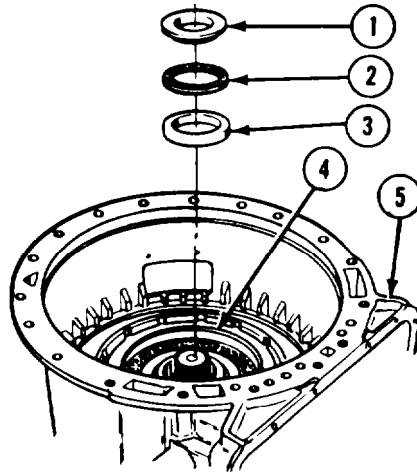

WARNING

Be sure forward clutch hub and fourth clutch driving hub are installed in the forward clutch assembly. If these two hubs are installed into the fourth clutch housing, the transmission will operate in reverse when the driver selects any forward range.

- (1) Install outer race (1), roller bearing (2), and inner race (3) on fourth clutch assembly (4) in transmission housing (5).

Transmission Maintenance Instructions (Cont)

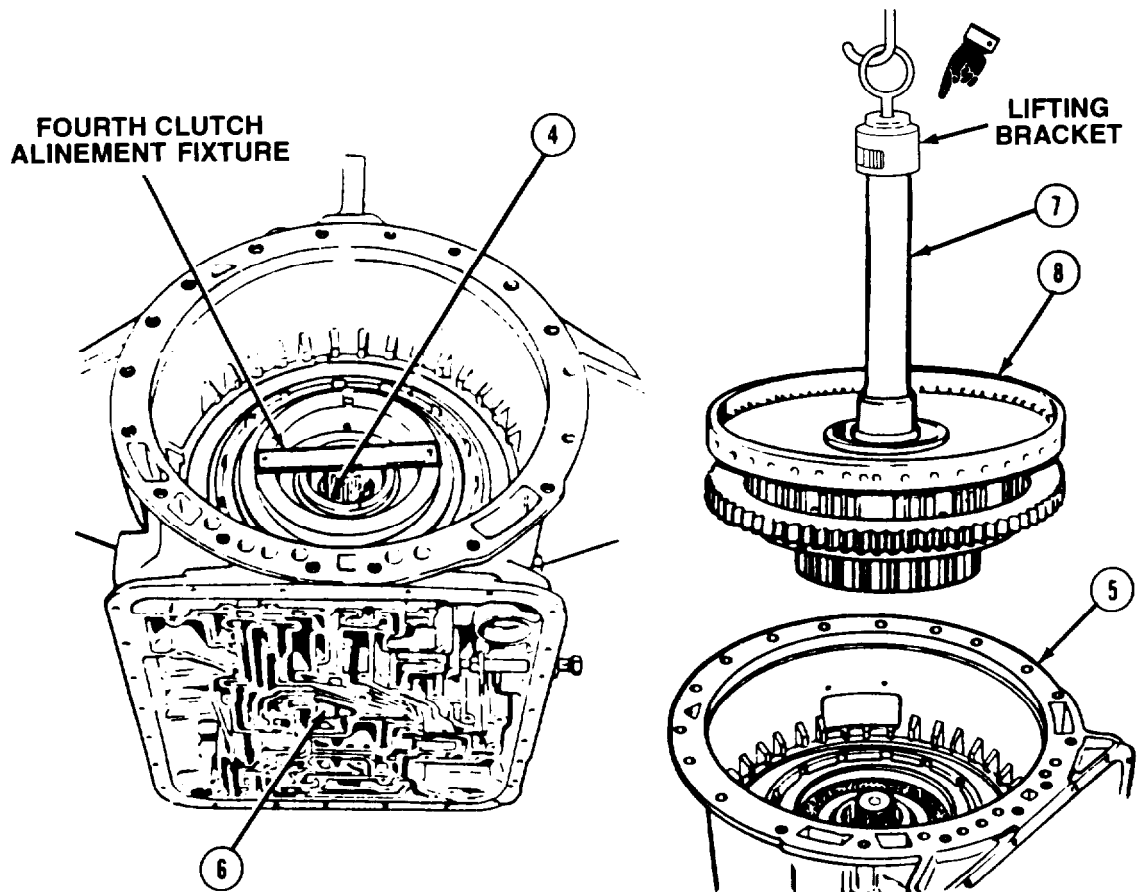

- (1.1) Install lifting bracket on turbine shaft (7).
- (2) Install fourth clutch alinement fixture on fourth clutch assembly (4).

WARNING

Compressed air can cause injury. Compressed air in shop will not exceed 30 psi (207 kPa). Use only with effective chip guarding and personal protective equipment, goggles, shield, and gloves.

- (3) Apply air pressure to port (6) to lock up fourth clutch plates.
- (4) Soldier A holds air pressure in fourth clutch assembly (4) while Soldier B removes fourth clutch alinement fixture.
- (5) Soldier A continues to apply air pressure in fourth clutch assembly (4) while Soldier B lifts and installs forward clutch assembly (8) by turbine shaft (7) into transmission housing (5).
- (6) Soldier A stops applying air pressure when Soldier B says forward clutch assembly (8) is fully seated in transmission housing (5).

f. Follow-on Maintenance.

- (1) Install torque converter housing (para 7-9).
- (2) Install control valve body (para 7-20).

END OF TASK

Transmission Maintenance Instructions (Cont)

7-16. REAR COVER AND FIRST CLUTCH ASSEMBLY REMOVAL/REPAIR/INSTALLATION.										
This task covers:										
a. Removal	d. Assembly									
b. Disassembly	e. Installation									
c. Cleaning/Inspection	f. Follow-on Maintenance									
INITIAL SETUP										
Models All	Personnel Required MOS 63W, Wheel vehicle repairer (2)									
Test Equipment None	Reference None									
Special Tools Clutch spring compressor J24204 Output shaft bushing installer J24203	Equipment Condition									
Supplies Oil, lubricating, Item 46, Appendix C Solvent, dry cleaning, Item 57, Appendix C Compound, retaining, Item 24, Appendix C Compound, sealing, pipe thread, Item 29, Appendix C Grease, general purpose, lithium base, Item 36, Appendix C	<table border="0"> <tr> <td>TM or Para</td> <td>Condition</td> <td>Description</td> </tr> <tr> <td>Para 7-14</td> <td>Output yoke, dust shield, and oil seal removed.</td> <td></td> </tr> <tr> <td>Para 7-23</td> <td>Governor removed.</td> <td></td> </tr> </table>	TM or Para	Condition	Description	Para 7-14	Output yoke, dust shield, and oil seal removed.		Para 7-23	Governor removed.	
TM or Para	Condition	Description								
Para 7-14	Output yoke, dust shield, and oil seal removed.									
Para 7-23	Governor removed.									
	Special Environmental Conditions None									
	General Safety Instructions None									
	Level of Maintenance General Support									

- a. Removal.
- (1) Position transmission (1) so output shaft (2) is pointing up.
 - (2) Install yoke (3) and nut (4).
 - (3) Remove three screws (5) and lockwashers (6).
 - (4) Remove 21 screws (7) and lockwashers (8).

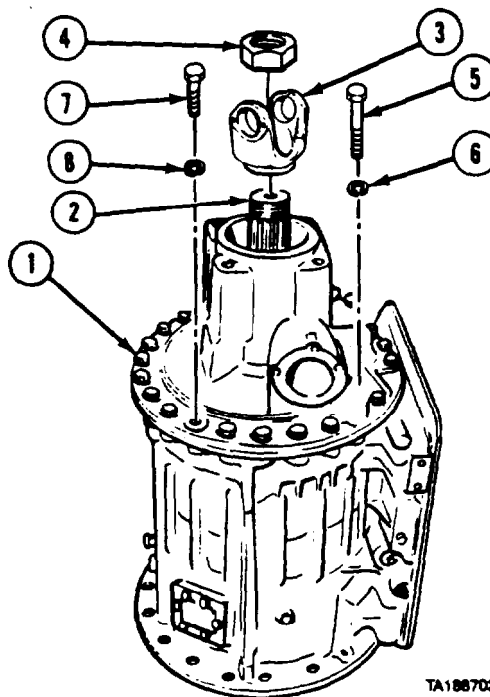

TA188702

Transmission Maintenance Instructions (Cont)

- (5) Install suiting lifting device to rear cover (9).
- (6) Soldier A guides rear cover (9) off and away from transmission (1) while Soldier B operates lifting device. Soldier B removes lifting device.
- (7) Remove gasket (10) from transmission (1).

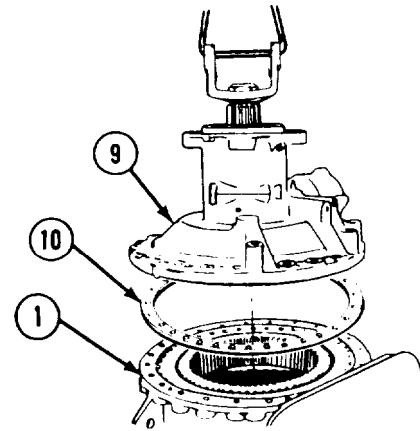

NOTE

Some clutch assemblies contain paper friction plates. Discard all paper friction plates. They are replaced by graphite friction plates.

- (8) Remove two steel plates (11), one friction plate (12), and rear planetary ring gear (13) from transmission housing (1).
- (9) Remove five friction plates (12) and five steel plates (11) from transmission housing (1).

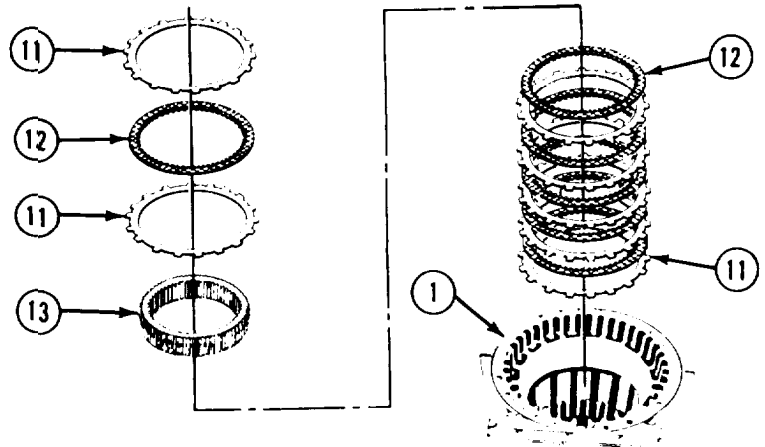

b. Disassembly.

- (1) Set rear cover (1) on wooden blocks.
- (2) Remove nut (2), yoke (3), and output shaft bearing retaining ring (4).
- (3) Remove plug (5), plug (6), plug (7), and bushing (8) from rear cover (1).

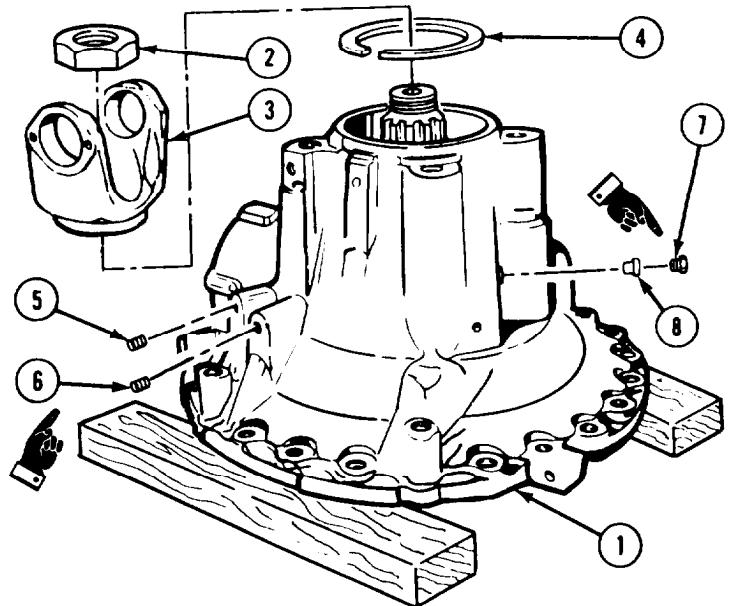

Transmission Maintenance Instructions (Cont)

7-16. REAR COVER AND FIRST CLUTCH ASSEMBLY REMOVAL/REPAIR/INSTALLATION. (CONT).

- (4) Position rear cover (1) on side. Use wooden block for support.
- (5) Remove output shaft (7) from rear cover (1).

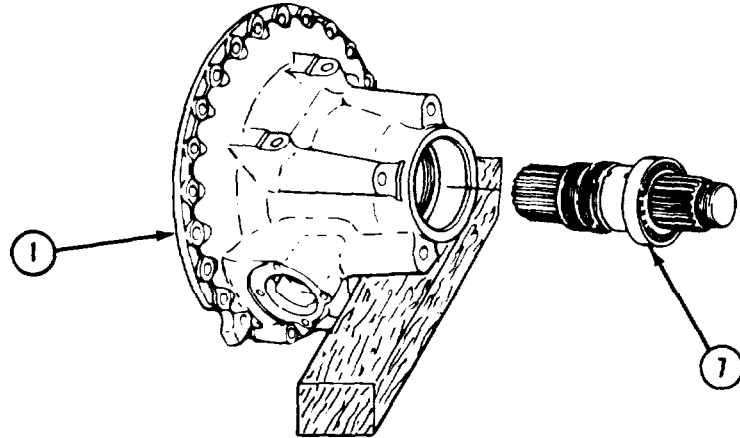

- (6) Press output shaft (7) from bearing (8), spacer (9), and speedometer drive gear (10).

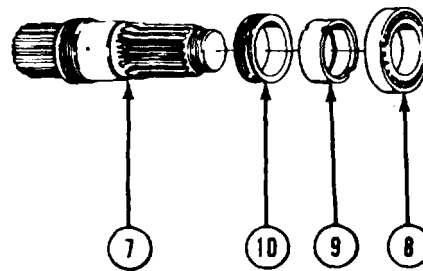

- (7) Screw long screw (11) into small orifice plug (12). Pry up on screw to remove plug.
- (8) Remove bushing (13) from output shaft (7).

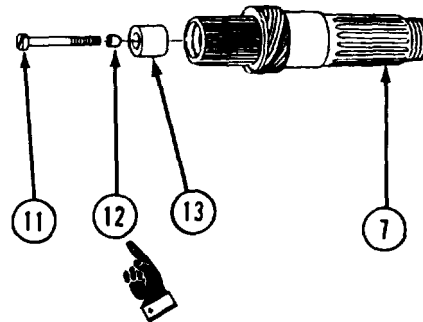

Transmission Maintenance Instructions (Cont)

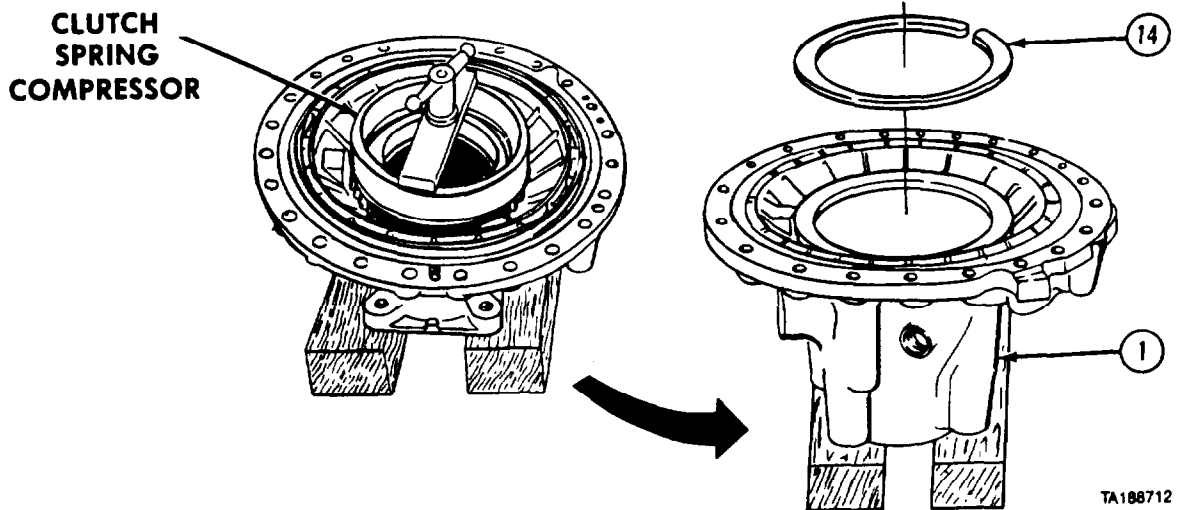

- (9) Position rear cover (1) flange side up.
- (10) Install clutch spring compressor inside rear cover (1).
- (11) Compress clutch spring compressor and remove large external retaining ring (14).
- (12) Remove clutch spring compressor.

- (13) Remove piston spring retainer (15) from first clutch piston (16).
- (14) Remove 30 piston release springs (17) from first clutch piston (16).
- (15) Remove first clutch piston (16) from rear cover (1).
- (16) Remove dowel pins (18 and 19) from rear cover (1).

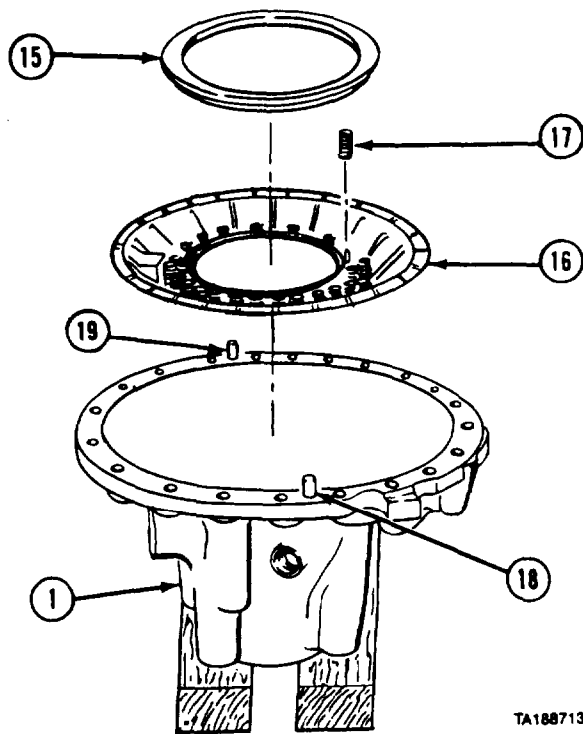

Transmission Maintenance Instructions (Cont)

7-16. REAR COVER AND FIRST CLUTCH ASSEMBLY REMOVAL/REPAIR/INSTALLATION (CONT).

- (17) Remove inner seal ring (20) and outer seal ring (21) from first clutch piston (16).

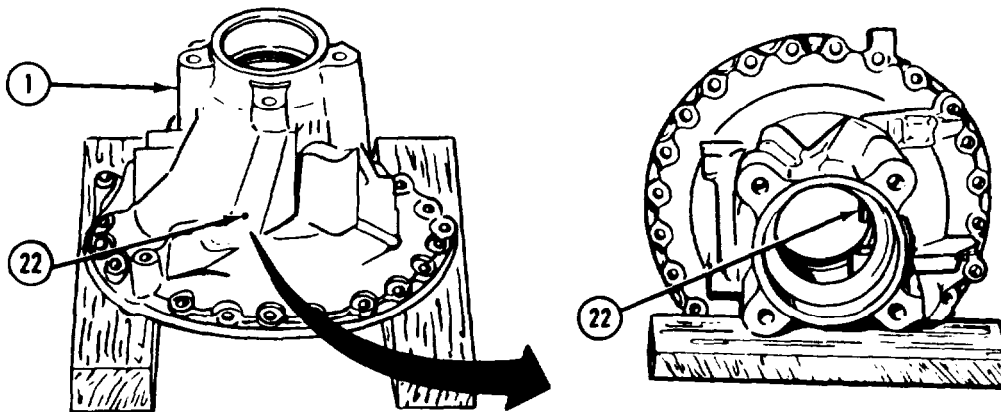
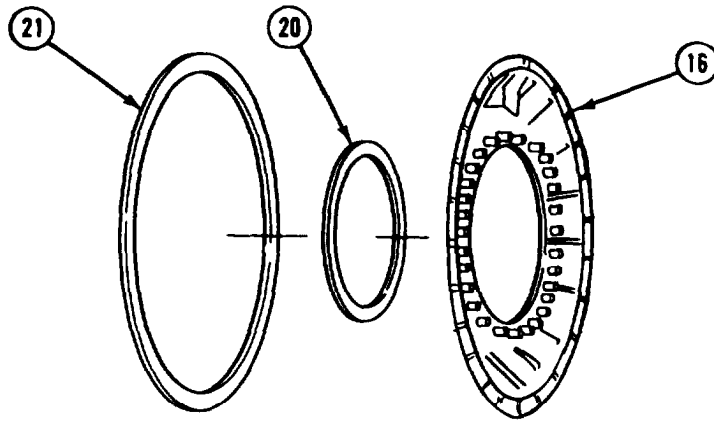

- (18) Position rear cover (1) flange side down. Use wooden blocks for support.
 (19) Remove governor support pin (22) from rear cover (1).

C. Cleaning/Inspection.

WARNING

Adhesives, solvents, and sealing compounds can burn easily, can give off harmful vapors, and are harmful to skin and clothing. To avoid injury or death, keep away from open fire and use in well-ventilated area. If adhesive, solvent, or sealing compound gets on skin or clothing, wash immediately with soap and water.

- (1) Clean all metal parts with drycleaning solvent and inspect for damage. Replace damaged parts.
 (2) Inspect and replace piston release springs if any five springs do not meet the following load-height requirements:
 (a) Length without load must be at least: 1.31 in. (33.3 mm).
 (b) Length under load must be at least: 0.90 in. (22.9 mm) with load of 26.05 to 27.85 lb (115.9 to 123.9 N).

Transmission Maintenance Instructions (Cont)

- (3) Measure inside diameter of bushing (1).
- (4) Check clearance between diameter of main shaft bearing surface, measured in paragraph 7-13, and bushing diameter measured in step (3). Clearance must not be greater than 0.004 in. (0.10 mm).
- (5) Inspect ends and outside diameter of the governor support pin (2) for wear. If worn, replace pin.

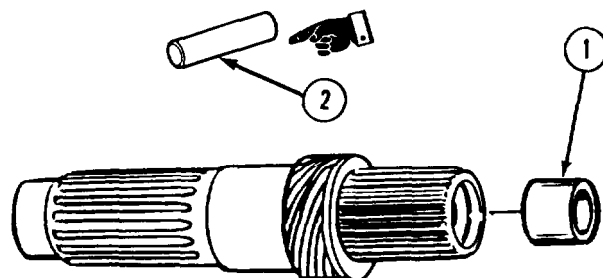

d. Assembly.

NOTE

Some clutch assemblies contain paper friction plates. When servicing clutch assembly, replace all paper friction plates with graphite friction plates. Paper friction plates and graphite friction plates cannot be intermixed within the same clutch assembly. Refer to TM 9-2320-279-24P for identification of parts.

- (1) Stack 13 clutch plates (1 and 2) on flat surface of press, starting with steel plate (1) and alternating with friction plate (2).
- (2) Place first clutch piston (3) on top of clutch plates (1 and 2).

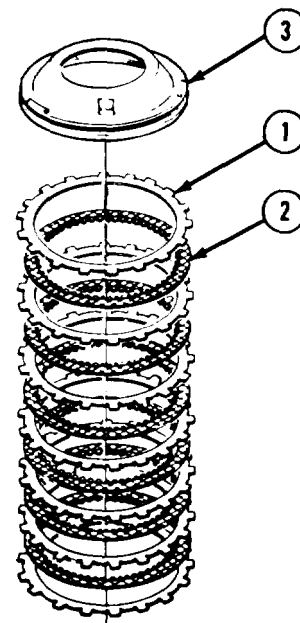

- (3) Press evenly on first clutch piston (3) with 980 to 1020 lb load (4359 to 4536.9 N).
- (4) Measure distance from base of clutch pack (4) to thrust pad (5).
- (5) Clutch pack thickness must be 2.521 to 2.553 in. (64.03 to 64.55 mm). Replace clutch plates (1 and 2) as needed to ensure proper clutch pack thickness.
- (6) Measure thickness of one tang (6) on each of seven steel plates (1).
 - (a) If steel plate measures 0.116 to 0.123 in. (2.95 to 3.12 mm), steel plate is thick.
 - (b) If steel plate measures 0.099 to 0.106 in. (2.51 to 2.70 mm), steel plate is thin.
- (7) Repeat steps (1) to (5) to recheck clutch pack thickness.
- (8) Remove first clutch piston (3) and clutch pack (4) from press.

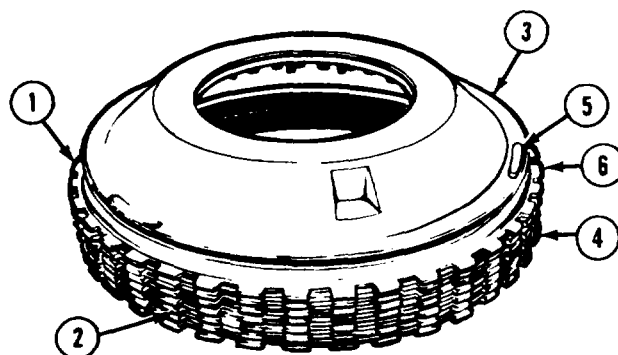

Transmission Maintenance Instructions (Cont)

7-16. REAR COVER AND FIRST CLUTCH ASSEMBLY REMOVAL/REPAIR/INSTALLATION (CONT).

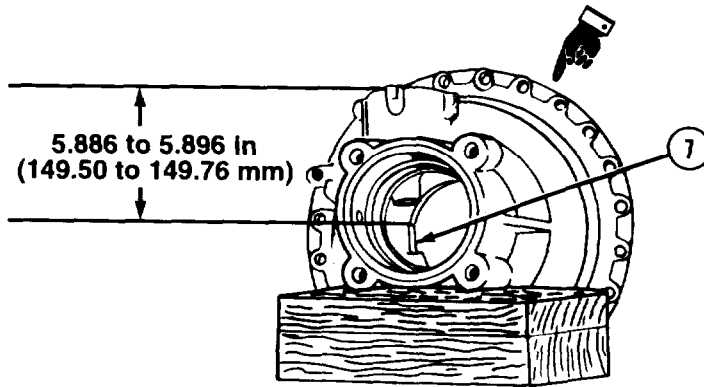
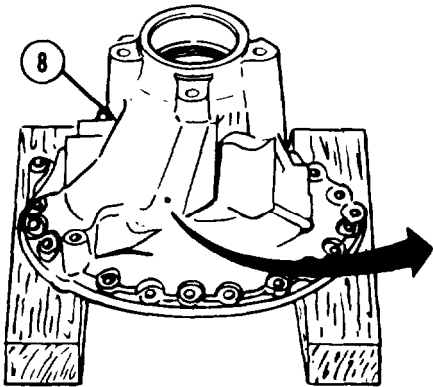

CAUTION

Accuracy of location and alignment with the governor bore is critical when installing pin.

- (9) Install governor support pin (7) in rear cover (8) to a depth of 5.886 to 5.896 in. (149.50 to 149.76 mm).
- (10) Coat inner seal ring (9) and outer seal ring (10) with lubricating oil.
- (11) Install inner seal ring (9) and outer seal ring (10) on first clutch piston (3) with lips facing down.

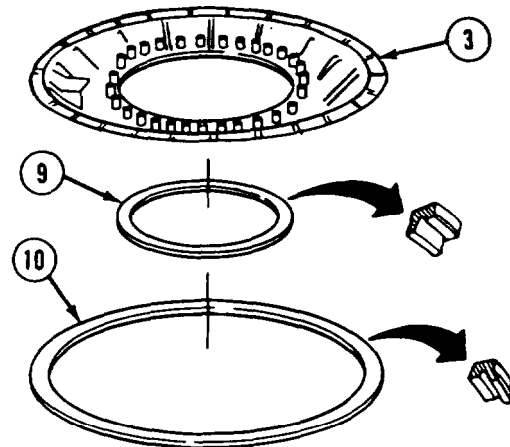

- (12) Install first clutch piston (3) in rear cover (8).
- (13) Install two dowel pins (11 and 12) and set pins height to 0.36 to 0.40 in. (9.14 to 10.16 mm) above the face of the cover.

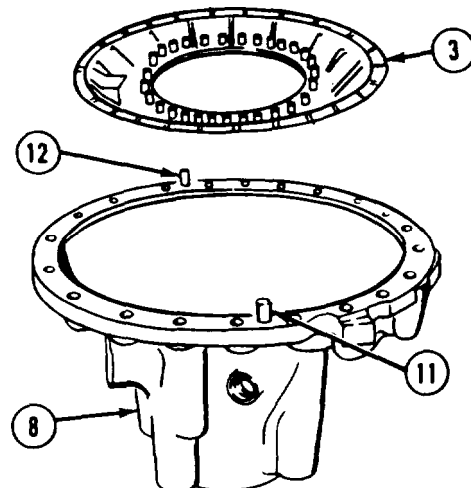

Transmission Maintenance Instructions (Cont)

- (14) Install 30 piston release springs (13) in first clutch piston (3).
- (15) Install piston spring retainer (14) on piston release springs (13).
- (16) Using clutch spring compressor, push down on piston spring retainer (14) and piston release springs (13) until retaining ring groove in rear cover (8) is cleared.
- (17) Install retaining ring (15). Remove clutch spring compressor.

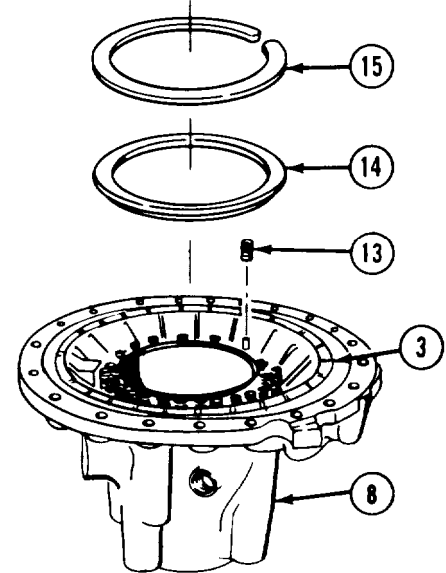

NOTE

The orifice plug must clear the chamfer at the front of the plug bore in the output shaft.

- (18) Install small orifice plug (16) in output shaft (17).

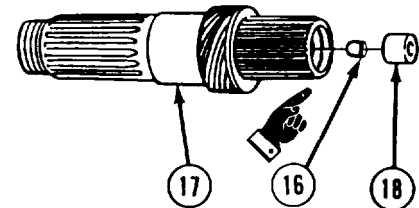

NOTE

Bushing must be 0.145 to 0.165 in. (3.68 to 4.19 mm) from front end of output shaft.

- (19) Coat output shaft bushing (18) with retaining compound.
- (20) Install output shaft bushing (18) in output shaft (17) using output shaft bushing installer.
- (21) Install speedometer drive gear (19), spacer (20), and bearing (21) on output shaft (17).
- (22) Install output shaft (17) in rear cover (8).

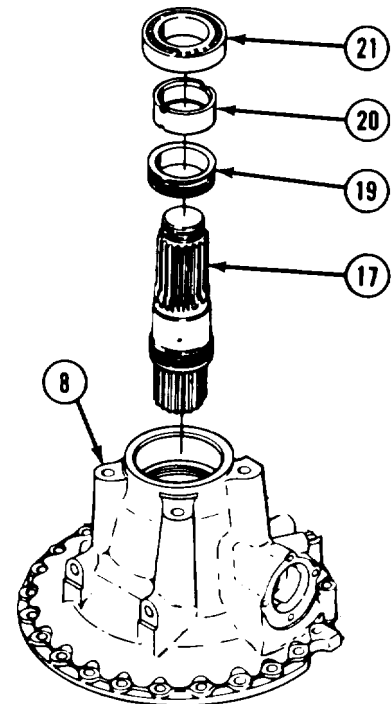

Transmission Maintenance instructions (Cont)

7-16. REAR COVER AND FIRST CLUTCH ASSEMBLY REMOVAL/REPAIR/INSTALLATION (CONT).

- (23) Install retaining ring (22), yoke (23), and nut (24).

WARNING

Adhesives, solvents, and sealing compounds can burn easily, can give off harmful vapors, and are harmful to skin and clothing. To avoid injury or death, keep away from open fire and use in well-ventilated area. If adhesive, solvent, or sealing compound gets on skin or clothing, wash immediately with soap and water.

- (24) Lightly coat threads of plug (25) and plug (25.1) with pipe thread sealing compound and install in rear cover (8).
- (25) Install bushing (25.2) and plug (26) in rear cover (8).
- (26) Torque plug (25), plug (25.1), and plug (26) to 4 to 5 lb-ft (5 to 7 N•m).

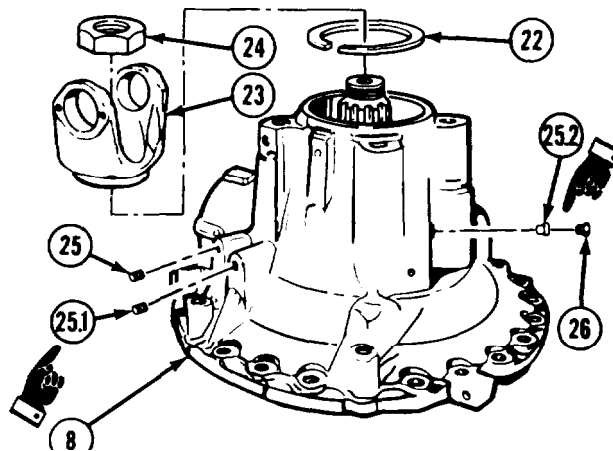

e. **Installation.**

- (1) Soak six friction plates (1) in clean lubricating oil for at least 2 minutes.

NOTE

If thick steel clutch plates are included in clutch plate stack, install thick steel clutch plates on top of stack for proper pressure distribution.

- (2) Install 10 clutch plates (1 and 2) in transmission housing (3), starting with steel plate (2) and alternating with friction plate (1).
- (3) Install rear planetary ring gear (4) in transmission housing (3).
- (4) Install three clutch plates (1 and 2) in transmission housing (3), starting with steel plate (2) and alternating with friction plate (1).

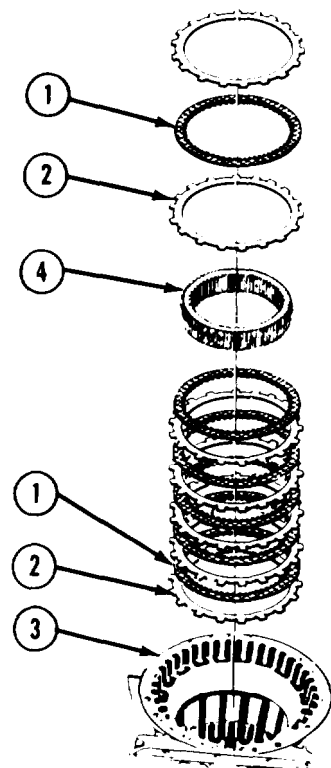

Transmission Maintenance Instructions (Cont)

- (5) Lightly coat one side of gasket (5) with grease.
- (6) Set gasket (5) on transmission (3) with greased side of gasket down.
- (7) Aline holes in gasket (5) with holes in transmission (3).
- (8) Install sling lifting device on rear cover (6).

NOTE

There are two different size dowel pins on screw flange face of rear cover to help aline cover with transmission.

- (9) Soldier A alines screw holes and installs rear cover (6) on transmission (3) while Soldier B operates lifting device. Soldier B removes lifting device.

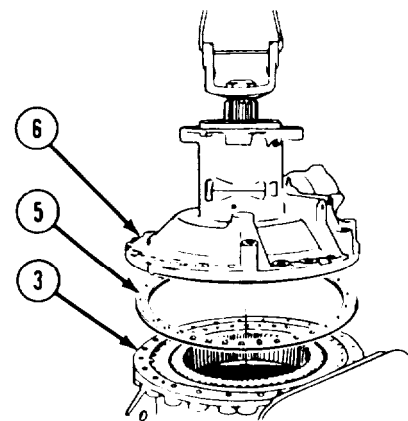

- (10) Install 21 screws (7) with lockwashers (8).
- (11) Install three screws (9) with lockwashers (10).
- (12) Tighten screws (7 and 9) alternately to 67 to 80 lb-ft (91 to 108 N•m).
- (13) Remove nut (11) and yoke (12).

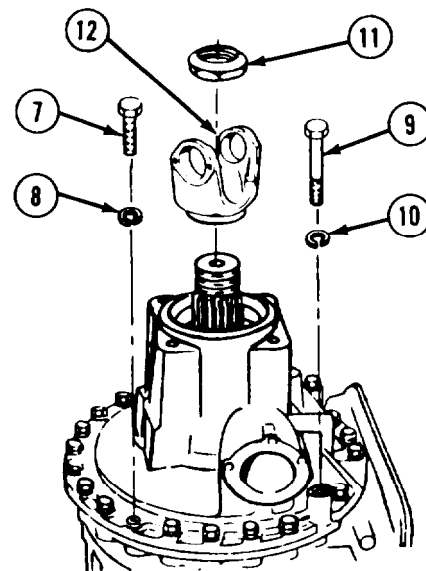

f. Follow-on Maintenance.

- (1) Install governor (para 7-23).
- (2) Install output yoke, dust shield, and oil seal (para 7-14).

END OF TASK

Transmission Maintenance Instructions (Cont)

7-17. FOURTH CLUTCH ASSEMBLY REMOVAL/REPAIR/INSTALLATION.

This task covers:

- | | |
|------------------------|--------------------------|
| a. Removal | d. Assembly |
| b. Disassembly | e. Installation |
| c. Cleaning/Inspection | f. Follow-on Maintenance |

INITIAL SETUP

Models

All

References

None

Test Equipment

None

Equipment Condition

Special Tools

Clutch spring compressor J24204

TM or Para

Para 7-15

Condition Description

Forward clutch assembly removed.

Supplies

Oil, lubricating, Item 46, Appendix C
 Ties, cable, plastic, Item 65, Appendix C
 Solvent, dry cleaning, Item 57, Appendix C
 Grease, general purpose, lithium base, Item 36, Appendix C

Special Environmental Conditions

None

General Safety Instructions

None

level of Maintenance

General Support

Personnel Required

MOS 63W. Wheel vehicle repairer

a. Removed.

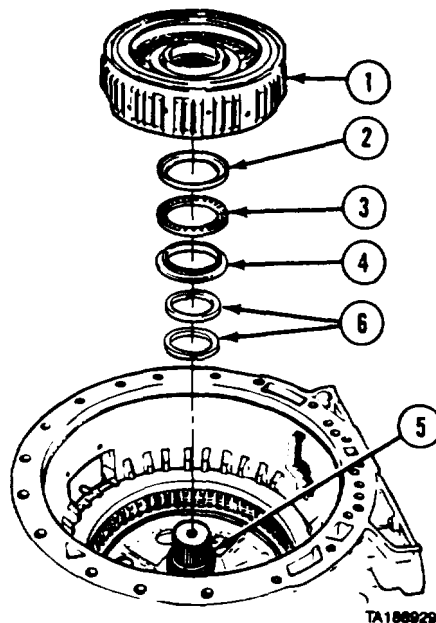

- (1) Remove fourth clutch assembly (1).
- (2) Remove race (2), bearing (3), and race (4) from center support (5) and fourth clutch assembly (1).
- (3) Remove two seal rings (6) from center support (5).

Transmission Maintenance Instructions (Cont)

b. Disassembly.

- (1) Position fourth clutch housing (1) with front hub (2) up and remove large retaining ring (3) and backplate (4).
- (2) Remove five steel plates (5) and five friction plates (6) from fourth clutch housing (1).

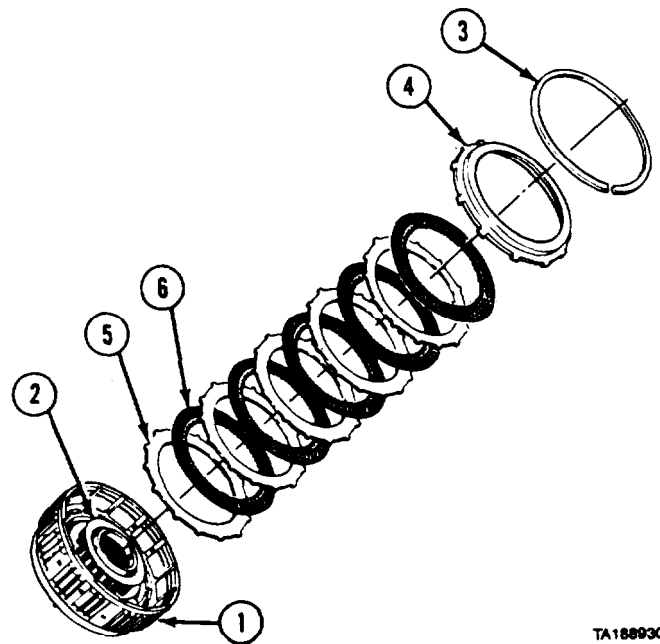

TA168930

- (3) Install fourth clutch housing (1) in hydraulic press.
- (4) Compress spring retainer (7) with clutch spring compressor. Remove retaining ring (8).
- (5) Release pressure from spring retainer (7) and remove clutch spring compressor.
- (6) Remove fourth clutch housing (1) from press.

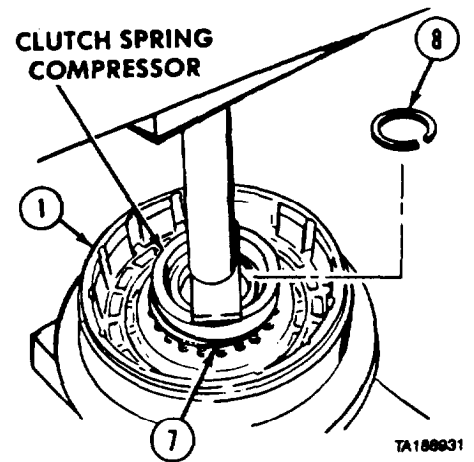

TA168931

- (7) Remove spring retainer (7) from fourth clutch piston (9).
- (8) Remove 20 piston release springs (10) from fourth clutch piston (9).

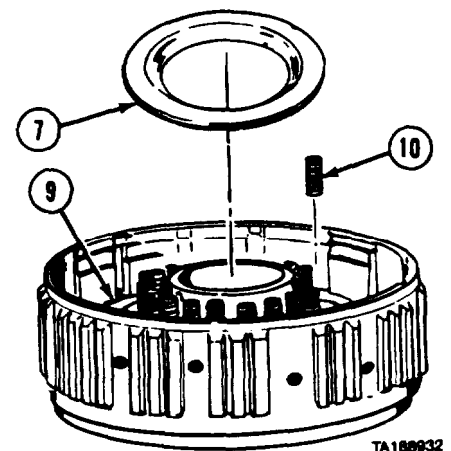

TA168932

Transmission Maintenance Instructions (Cont)

7-17. FOURTH CLUTCH ASSEMBLY REMOVAL/REPAIR/INSTALLATION (CONT).

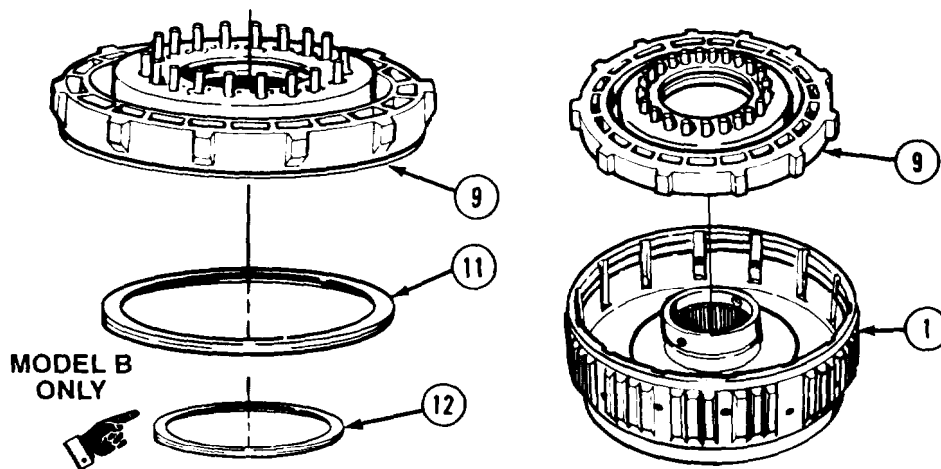

- (9) Remove fourth clutch piston (9) from fourth clutch housing (1).
- (10) Remove outer seal ring (11) from fourth clutch piston (9).

NOTE

There are two kinds of fourth clutch piston/fourth clutch housing assemblies. Model A has a large seal ring on the piston and a medium seal ring in the housing. Model B has a large seal ring and a small seal ring, both rings located on piston. The Model B housing does not have a seal ring. If a Model A housing must be replaced by a Model B housing, both the piston and seal rings must be replaced.

- (11) Remove inner seal ring (12) from fourth clutch housing (1) or fourth clutch piston (9).

c. Cleaning/Inspection.

WARNING

Adhesives, solvents, and sealing compounds can burn easily, can give off harmful vapors, and are harmful to skin and clothing. To avoid injury or death, keep away from open fire and use in well-ventilated area. If adhesive, solvent, or sealing compound gets on skin or clothing, wash immediately with soap and water.

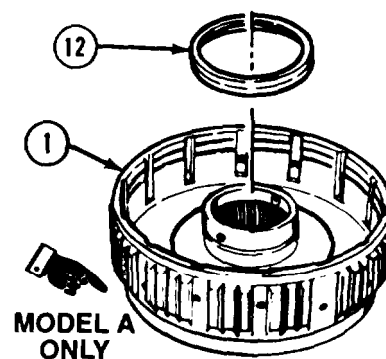

- (1) Clean all metal parts with drycleaning solvent and inspect for damage. Replace damaged parts.
- (2) Replace all piston release springs if any three do not meet the following load-height requirements:
 - (a) Length without load: Must be at least 1.25 in. (31.8 mm).
 - (b) Length under load: Must be at least 0.88 in. (22.4 mm) with load of 17.9 to 18.9 lb (79.6 to 84.1 N).

Transmission Maintenance Instructions (Cont)

- (3) Clean eight ball pockets (1) with dry cleaning solvent.

WARNING

Compressed air used for cleaning purposes will not exceed 30 psi (207 kPa). Use only with effective chip guarding and personal protective equipment, goggles, shield, and gloves.

- (4) Dry ball pockets (1) with compressed air.
- (5) Apply lubricating oil around area of ball pockets (1).
- (6) Insure steel balls are staked and move freely.

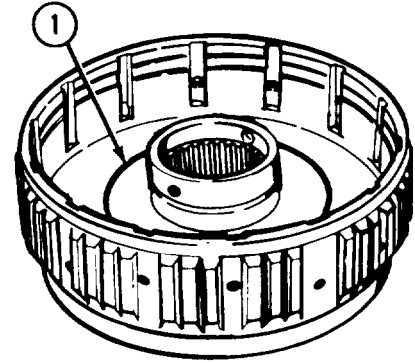

Transmission Maintenance Instructions (Cont)

d. Assembly.

NOTE

There are two kinds of fourth clutch piston/fourth clutch housing assemblies. Model A has a large seal ring on the piston and a medium seal ring in the housing. Model B has a large seal ring and a small seal ring, both rings located on the piston. The Model B housing does not have a seal ring. If a Model A housing must be replaced by a Model B housing, both the piston and seal rings must be replaced.

- (1) Check bottom of fourth clutch piston (1) and note whether labeled T, S, or M.

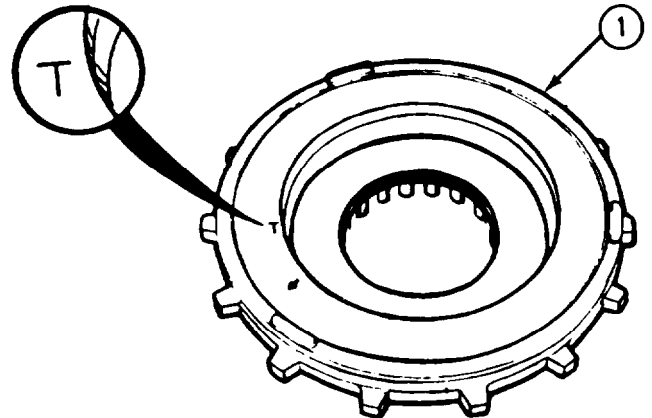

- (2) Stack 10 clutch plates (2 and 3) on flat surface of press starting with steel plate (2) and alternating with friction plate (3).
- (3) Place backplate (4) on clutch plates (2 and 3).

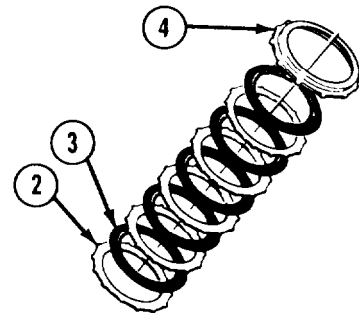

- (4) Press evenly on backplate (4) with 980 to 1020 lb load (4359 to 4536.9 N).
- (5) Measure distance from base of clutch pack (5) to machined surface (6) of backplate (4). This is clutch pack thickness.
- (6) If fourth clutch piston (1) is a T-piston, clutch pack thickness must be 1.361 to 1.387 in. (34.59 to 35.23 mm). If fourth clutch piston is an S-piston, clutch pack thickness must be 1.388 to 1.414 in. (35.26 to 35.92 mm). If fourth clutch piston is an M-piston, clutch pack thickness must be 1.415 to 1.441 in. (35.94 to 36.60 mm). If measurement of clutch pack thickness is other than stated above, replace clutch plates (2 and 3) as needed.

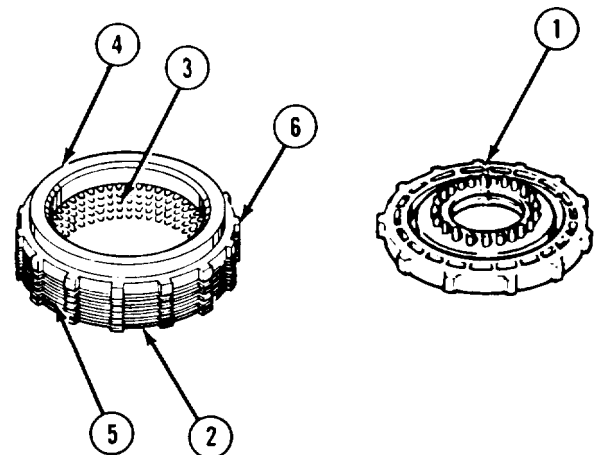

- (7) Remove clutch pack (5) and backplate (4) from press.

Transmission Maintenance Instructions (Cont)

7-17. FOURTH CLUTCH ASSEMBLY REMOVAL/REPAIR/INSTALLATION (CONT).

- (8) Coat seal ring (7) and outer rim of fourth clutch piston (1) with lubricating oil.
- (9) Install seal ring (7) on outer rim of fourth clutch piston (1) with seal ring lip (8) facing down.
- (10) Coat seal ring (9) and hub (10) of fourth clutch housing (11) with lubricating oil.

NOTE

For Model A, do step (11); for Model B do step (11.1).

- (11) Install seal ring (9) on hub (10) with seal ring lip (12) pointing down.
- (11.1) Install seal ring (9) on inner bore of fourth clutch piston (1) with seal ring lip pointing up.
- (12) Install fourth clutch piston (1) in fourth clutch housing (11).

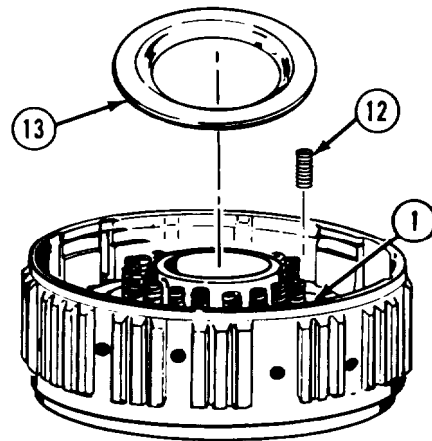
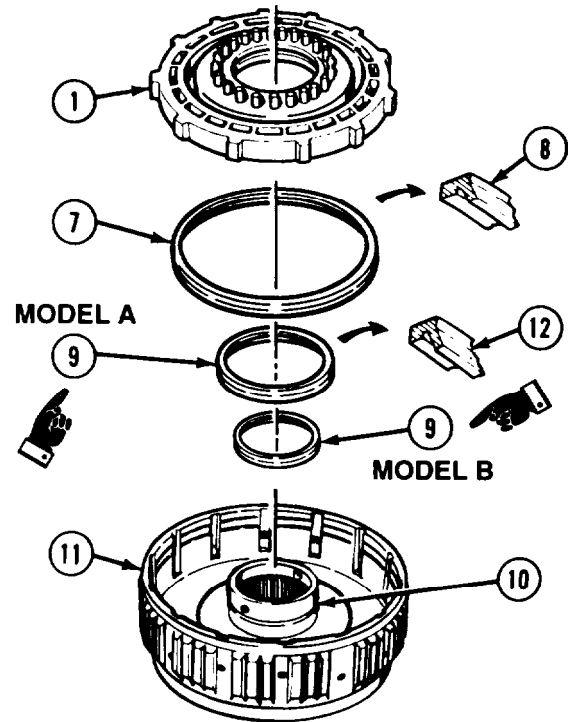

- (13) Install 20 piston release springs (12) on fourth clutch piston (1).
- (14) Install piston release spring retainer (13) on piston release springs (12).

Transmission Maintenance Instructions (Cont)

- (15) Install fourth clutch housing (11) in hydraulic press.
- (16) Compress piston release spring retainer (13) with clutch spring compressor and press. Install retaining ring (14).
- (17) Release pressure from piston release spring retainer (13) and remove clutch spring compressor.
- (18) Remove fourth clutch housing (11) from press.

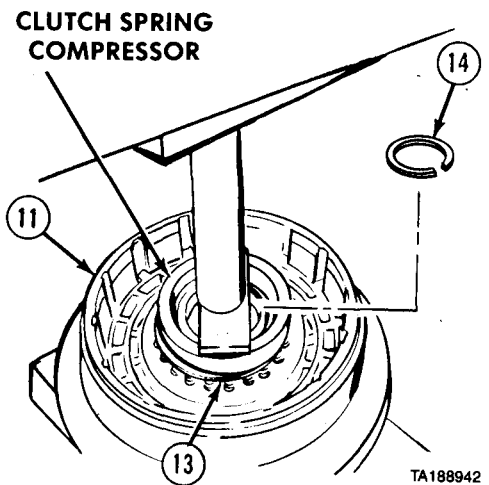

- (19) Install 10 clutch plates (2 and 3), starting with steel plate (2) and alternating with friction plate (3).
- (20) Install backplate (4) and retaining ring (15).

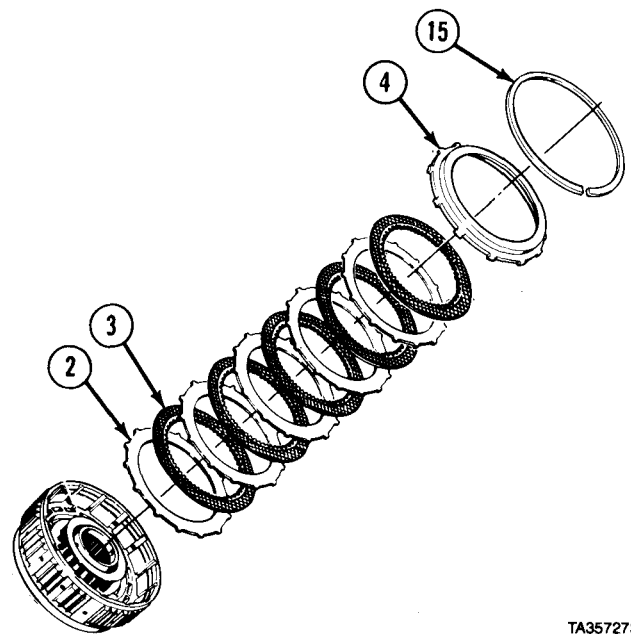

e. Installation.

- (1) Apply lubricating oil to inner bearing race (1) and bearing (2) and install on center support housing hub (3).

CAUTION

Keep seal rings sealed in packages until ready to use to keep seal rings from being damaged.

- (2) Roll seal rings (4) one-half length and hold for at least 10 seconds.
- (3) Install one seal ring (4) in lower groove on center support housing hub (3).
- (4) Install other seal ring (4) in upper groove on center support housing hub (3).

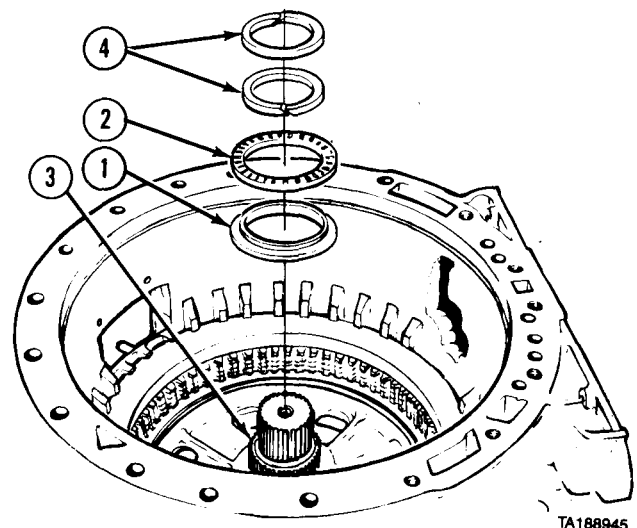

7-17. FOURTH CLUTCH ASSEMBLY REMOVAL/REPAIR/INSTALLATION (CONT).

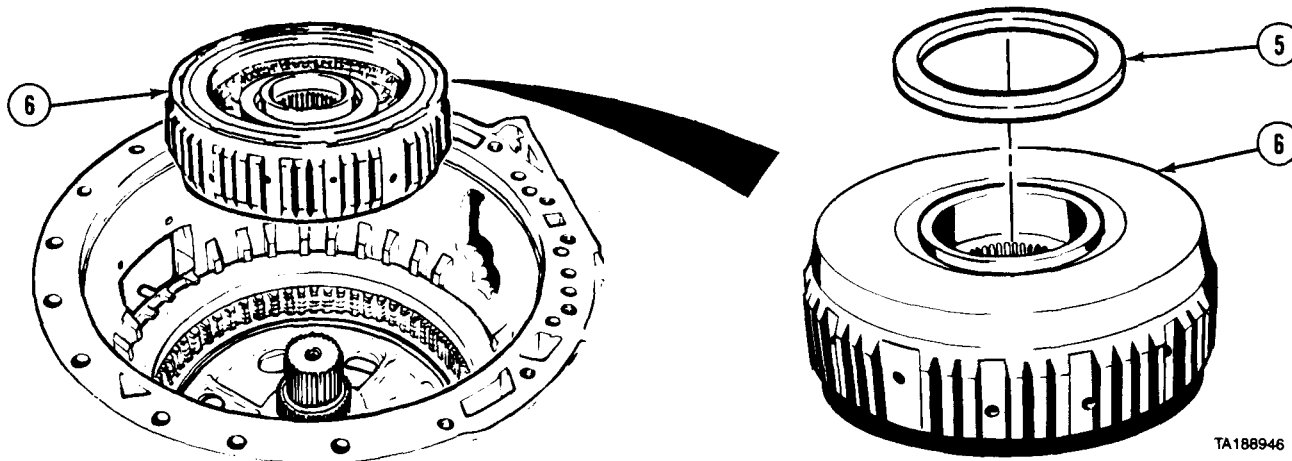

(5) Apply grease to outer bearing race (5) and install on bottom of fourth clutch assembly (6).

(6) Install fourth clutch assembly (6).

f. Follow-on Maintenance. Install forward clutch assembly (para 7-15).

END OF TASK

7-18. THIRD CLUTCH AND CENTER SUPPORT HOUSING REMOVAL/REPAIR/INSTALLATION.

This task covers:

- a. Removal
- b. Disassembly
- c. Cleaning/Inspection
- d. Assembly
- e. Installation
- f. Follow-on Maintenance

INITIAL SETUP

Models

All

Test Equipment

None

Special Tools

- Swaging tool J28525-1
- Sleeve, compressor J24208-2
- Compressor, center support J24208-3
- Gage, retaining ring J24208-13 or J34127

Supplies

- Oil, lubricating, Item 46, Appendix C
- Solvent, dry cleaning, Item 57, Appendix C

Personnel Required

MOS 63W, Wheel vehicle repairer

References

None

Equipment Condition

<i>TM or Para</i>	<i>Condition Description</i>
Para 7-17	Fourth clutch assembly removed.

Special Environmental Conditions

None

General Safety Instructions

None

Level of Maintenance

General Support

Transmission Maintenance Instructions (Cont)

a. Removal.

- (1) Remove retaining ring (1).
- (2) Remove backplate (2).
- (3) Remove four friction plates (3) and four steel plates (4).

NOTE

Some clutch assemblies contain paper friction plates. Discard all paper friction plates. They are replaced by graphite friction plates.

- (4) Remove support housing anchor screw (5) and washer (6).
- (5) Remove retaining ring (7) holding center support housing (8).

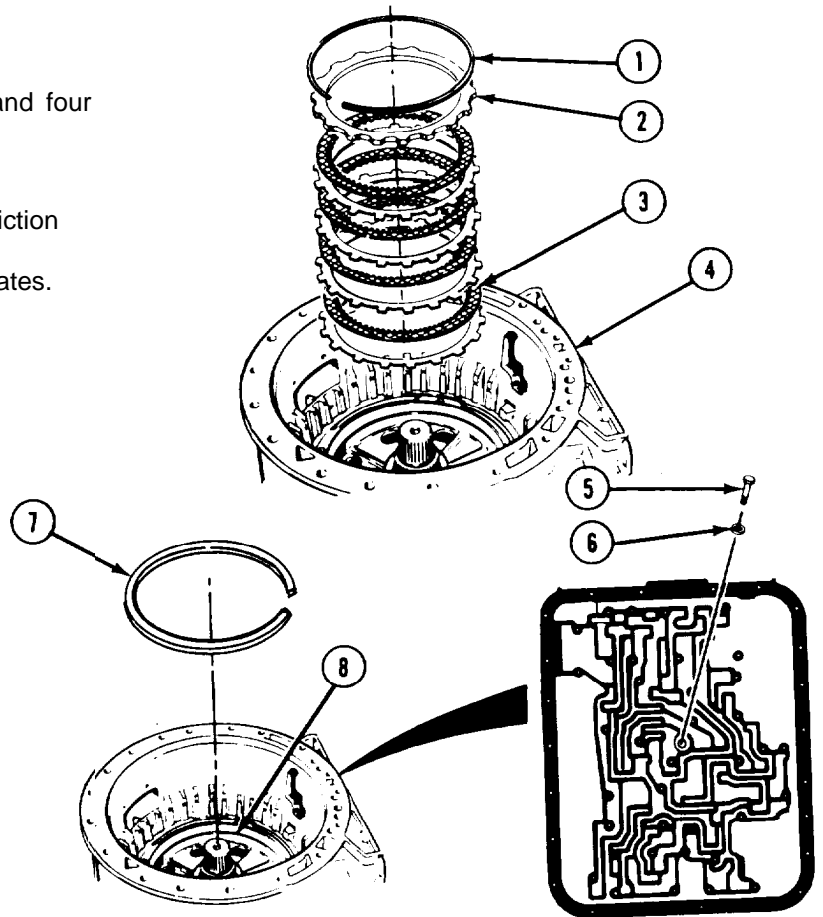

NOTE

- Center support housing is fitted to transmission housing with very little clearance and may bind if transmission housing is cold. Heat transmission housing with heat lamp or warm current of air.
 - If support housing starts upward and then binds, tap center support housing downward and lift again.
- (6) Lifting straight up, remove center support housing (8) and thrust washer (9) from transmission housing (10).

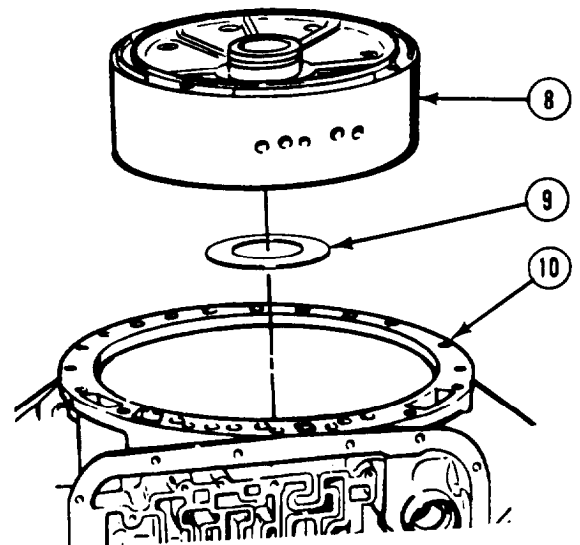

Transmission Maintenance Instructions (Cont)

7-18. THIRD CLUTCH AND CENTER SUPPORT HOUSING REMOVAL/REPAIR/INSTALLATION (CONT).

b. Disassembly.

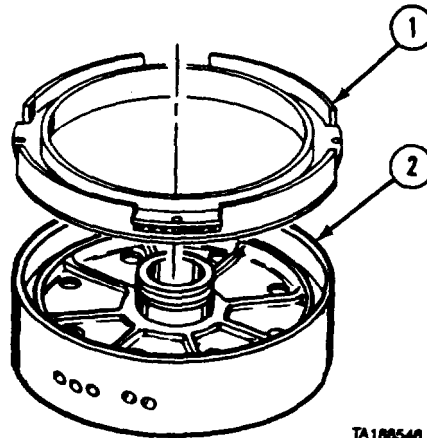

TA188546

(1) Remove third clutch piston (1) from center support housing (2).

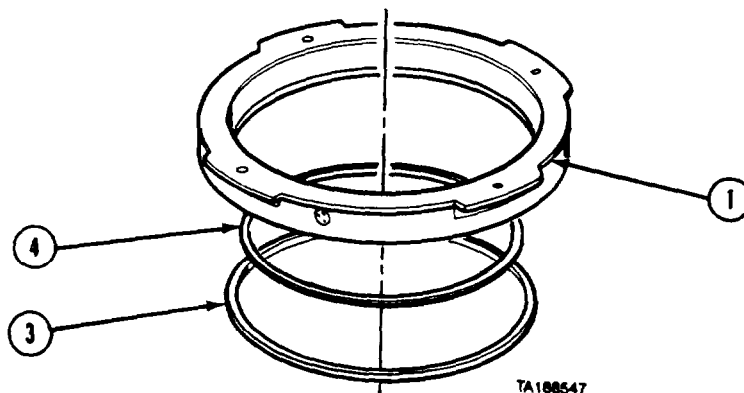

TA188547

(2) Remove outer seal ring (3) and inner seal ring (4) from third clutch piston (1).

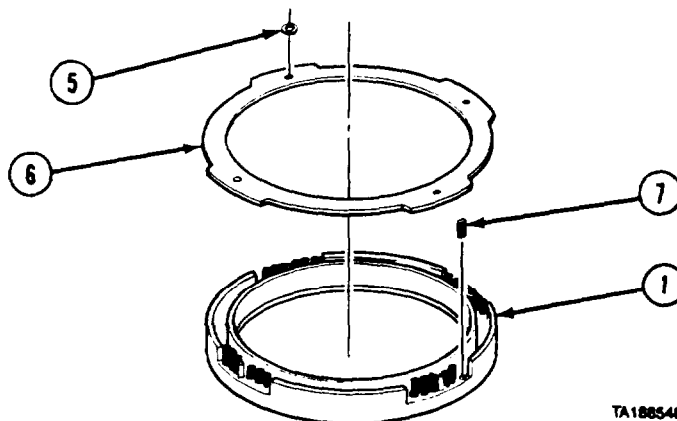

TA188548

(3) Cut and remove four retaining rings (5).
(4) Remove clutch ring (6) from third clutch piston (1).
(5) Remove 20 springs (7) from third clutch piston (1).

Transmission Maintenance Instructions (Cont)

- (6) Measure diameter of main shaft bearing surfaces (8) inside transmission housing (9).
- (7) Measure inside diameter of bushing (10).
- (8) If bushing (10) to main shaft bearing surface (8) clearance is greater than 0.009 in. (0.229 mm), remove bushing.

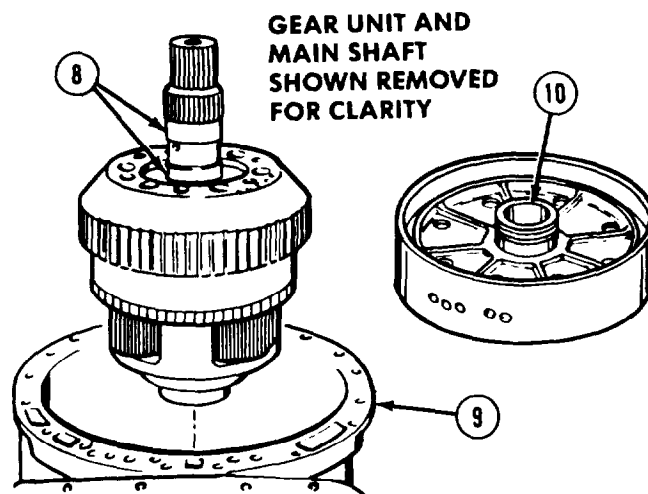

c. Cleaning/Inspection.

WARNING

Adhesives, solvents, and sealing compounds can burn easily, can give off harmful vapors, and are harmful to skin and clothing. To avoid injury or death, keep away from open fire and use in well-ventilated area. If adhesive, solvent, or sealing compound gets on skin or clothing, wash immediately with soap and water.

- (1) Clean all metallic parts with drycleaning solvent and inspect for damage. Replace damaged parts.
- (2) Replace piston release springs if any three of each set of 20 do not meet the following load-height requirements:
 - (a) Length without load must be at least 1.29 in. (32.8 mm).
 - (b) Length under load must be at least 0.82 in. (20.8 mm) with load of 4.3 to 5.7 lb (19.1 to 25.4 N).
- (3) Measure thrust washer thickness. Thickness must be no less than 0.091 in. (2.31 mm).

d. Assembly.

- (1) Place center support housing (1) on press, hub side up.
- (2) Install prebored bushing (2). Make sure oil hole in prebored bushing is aligned with oil hole in center support housing (1).

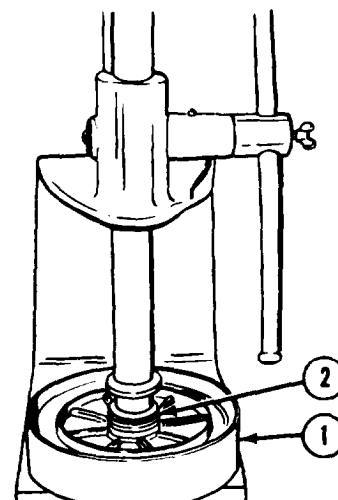

Transmission Maintenance Instructions (Cont)

7-18. THIRD CLUTCH AND CENTER SUPPORT HOUSING REMOVAL/REPAIR/INSTALLATION (CONT).

- (3) Use swaging tool to swage bushing (2) by staking edges of oilhole (3).

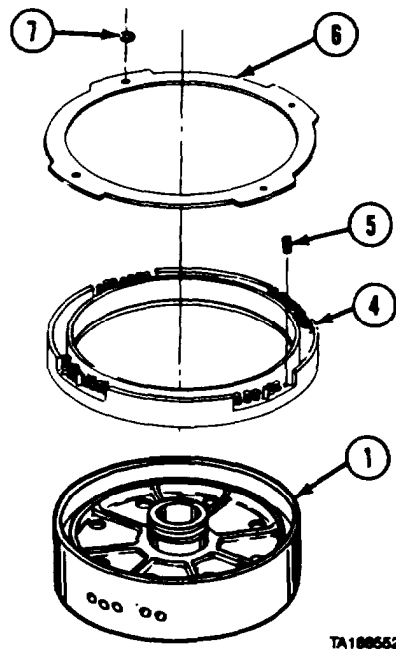
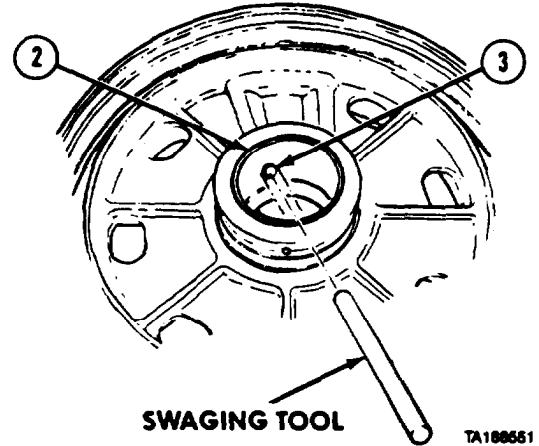

- (4) Set third clutch piston (4) in front cavity of center support housing (1).
(5) Install 20 piston release springs (5) in pockets on third clutch piston (4).
(6) Install clutch ring (6) on third clutch piston (4).

CAUTION

Clutch ring must be pushed completely down in center support housing while installing retaining rings or clutch clearance will be wrong and transmission will not shift properly.

- (7) Install four retaining rings (7). Remove third clutch piston (4) from support housing (1).

Transmission Maintenance Instructions (Cont)

- (8) Place backplate (8) on flat surface of press.

NOTE

Some clutch assemblies contain paper friction plates. When servicing clutch assembly, replace all paper friction plates with graphite friction plates. Paper friction plates and graphite friction plates cannot be intermixed within the same clutch assembly. Refer to TM 9-2320-279-24P for identification of parts.

- (9) Stack eight clutch plates (9 and 10) on backplate (8), starting with friction plate (9) and alternating with steel plate (10).
- (10) Place third clutch piston (4) on top of clutch plates (9 and 10).
- (11) Press evenly on third clutch piston (4) with 980 to 1020 lb load (4359 to 4536.9 N).
- (12) Measure distance from base of clutch pack (11) to thrust pad (12).
- (13) Clutch pack thickness must be 3.010 to 3.042 in. (76.45 to 77.26 mm). Replace clutch plates (9 and 10) as needed to ensure proper clutch pack thickness.
- (14) Measure thickness of one tang (13) on each of four steel plates (10).
- (a) If steel plate measures 0.116 to 0.123 in. (2.95 to 3.12 mm) steel plate is thick.
- (b) If steel plate measures 0.099 to 0.106 in. (2.51 to 2.69 mm) steel plate is thin.
- (15) Repeat steps (8) through (13) to recheck clutch pack thickness.
- (16) Remove clutch pack (11) from press.
- (17) Apply lubricating oil to inner seal ring (14) and outer seal ring (15).
- (18) Install inner seal ring (14) and seal ring (15) on third clutch piston (4) with lips facing down.

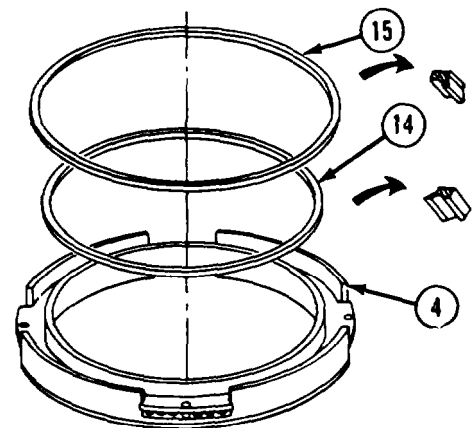
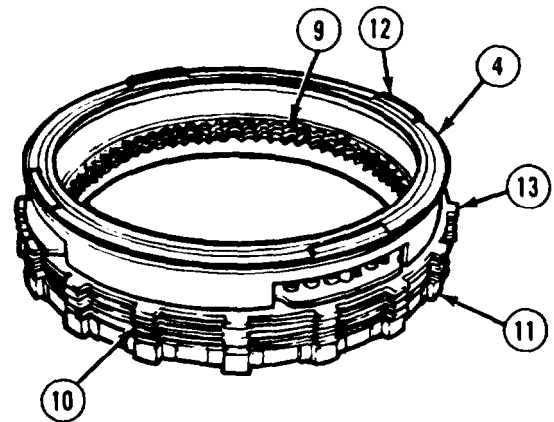
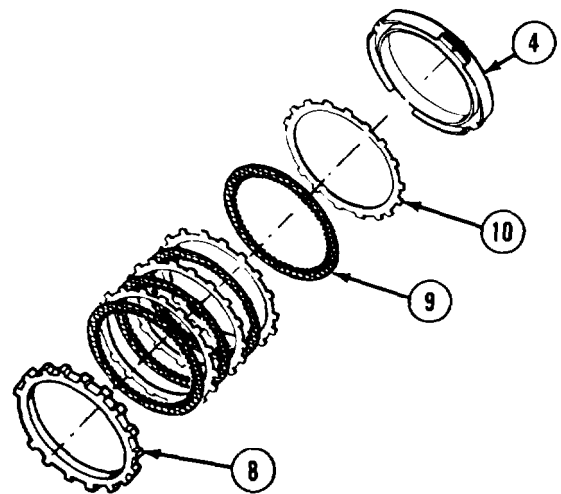

Transmission Maintenance Instructions (Cont)

7-18. THIRD CLUTCH AND CENTER SUPPORT HOUSING REMOVAL/REPAIR/INSTALLATION (CONT).

e. Installation.

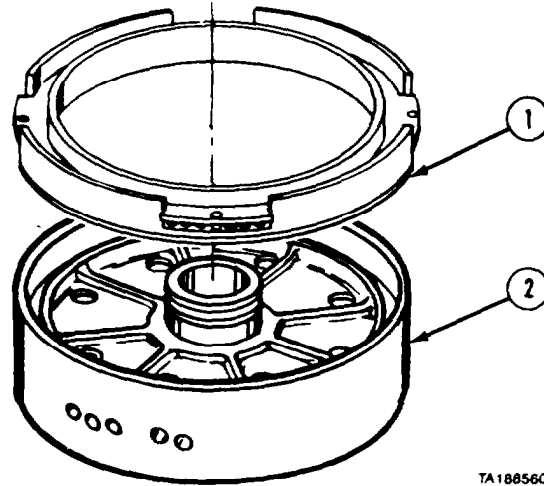

(1) Install third clutch piston (1) in center support housing (2).

(2) Install thrust washer (3).

NOTE

Center support housing is fitted to transmission housing with very little clearance and may bind if transmission housing is cold. Heat transmission housing with heat lamp or warm current of air.

(3) Lower center support housing (2) in transmission housing (4). Make sure tapped hole (5) in support housing is aligned with screw hole (6) in transmission housing.

(4) Install support housing anchor screw (7) and washer (8). Tighten support housing anchor screw finger-tight.

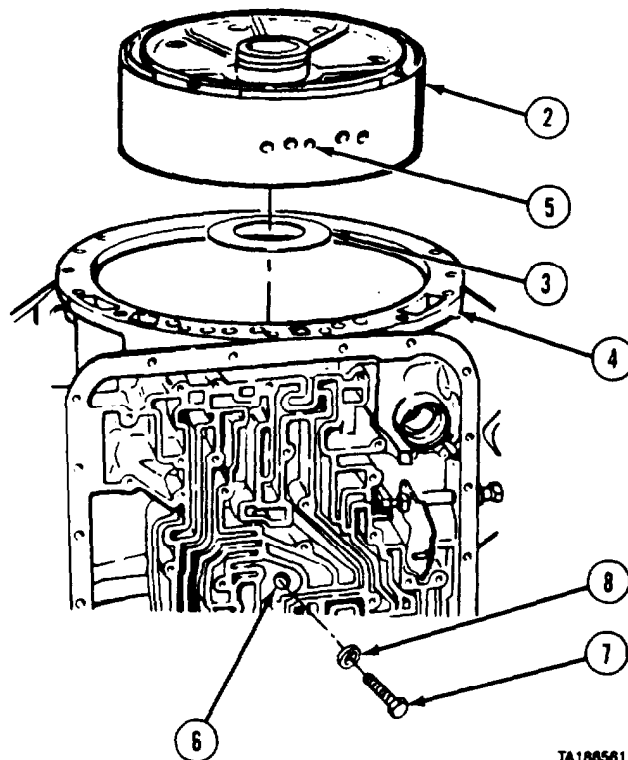

Transmission Maintenance Instructions (Cont)

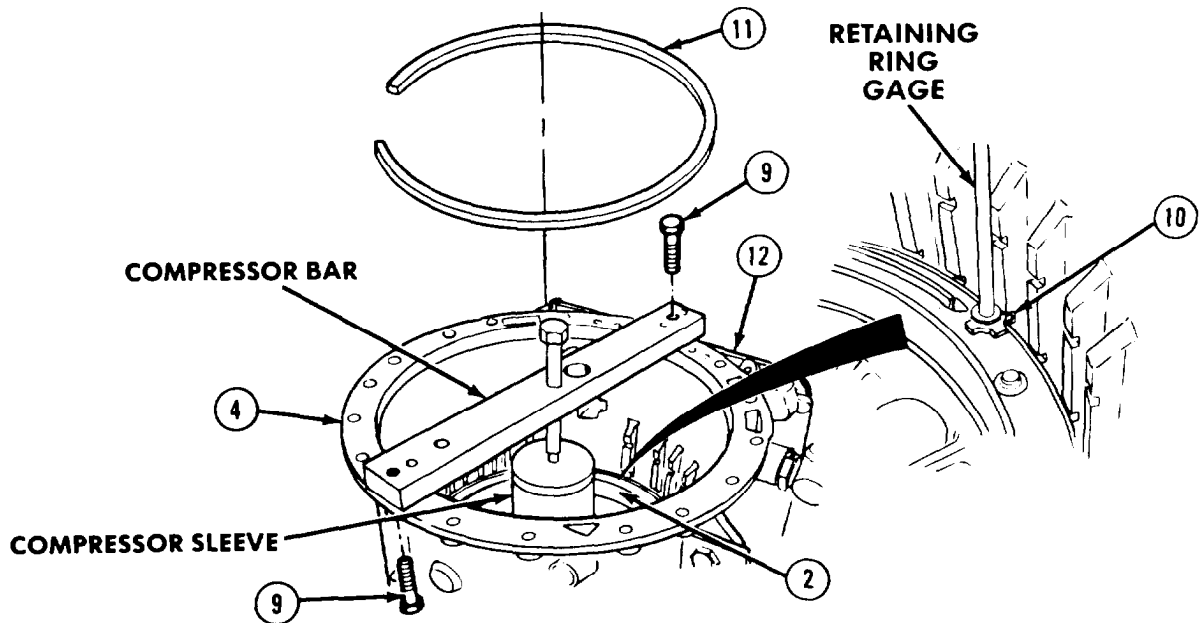

- (5) Install compressor sleeve on hub of center support housing (2) and place compressor bar across transmission housing (4) with two screws (9).
- (6) Tighten compressor center screw to 5 lb-ft (6.8 N•m) to compress center support housing (2).
- (7) Place snapping in retaining ring opening (10). Measure retaining ring opening with each of four colored lugs on gage to determine lug with tightest fit.
 - (a) Blue color coded retaining ring is 0.148 to 0.150 in. (3.76 to 3.81 mm) thick.
 - (b) Yellow color coded retaining ring is 0.152 to 0.154 in. (3.86 to 3.91 mm) thick.
 - (c) White color coded retaining ring is 0.155 to 0.157 in. (3.94 to 3.99 mm) thick.
 - (d) Red color coded retaining ring is 0.158 to 0.160 in. (4.01 to 4.06 mm) thick.
- (8) Install retaining ring (11) that has same color code as lug of gage. Retaining ring gap must be opposite oil pan side (12) of transmission housing (4).
- (9) Remove compressor bar and compressor sleeve.
- (10) Tighten support housing screw (7) to 39 to 46 lb-ft (53 to 62 N•m).

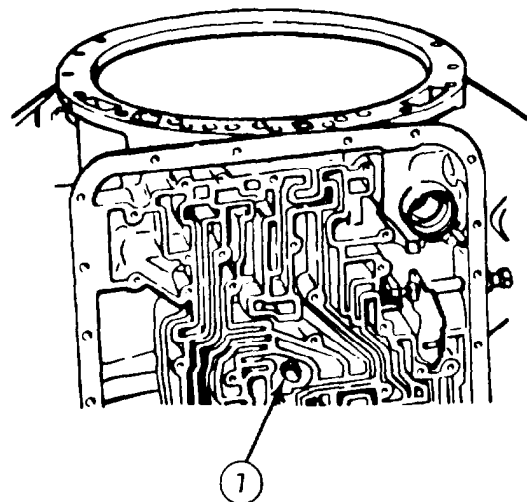

Transmission Maintenance Instructions (Cont)

7-18. THIRD CLUTCH AND CENTER SUPPORT HOUSING REMOVAL/INSTALLATION (CONT).

(11) Soak four friction plates (13) in oil for 2 minutes.

NOTE

Thick steel plates must be installed on bottom of stack.

(12) Install steel plate (14) with gap (15) facing as shown.

(13) Install seven clutch plates (13 and 14), starting with friction plate (13) and alternating with steel plate (14).

(14) Install backplate (16).

(15) Install retaining ring (17) with gap opposite oil pan side (12) of transmission housing (4).

f. **Follow-on Maintenance.** Install fourth clutch assembly (para 7-17).

END OF TASK

7-19. SECOND CLUTCH AND CENTER SUPPORT HOUSING REMOVAL/REPAIR/INSTALLATION.		
This task covers:		
a. Removal	d. Assembly	
b. Disassembly	e. Installation	
c. Cleaning/Inspection	f. Follow-on Maintenance	
INITIAL SETUP		
<i>Models</i>	<i>References</i>	
All	None	
<i>Test Equipment</i>	<i>Equipment Condition</i>	
None	<i>TM or Para</i>	<i>Condition Description</i>
<i>Special Tools</i>	Para 7-18	Third clutch and center support housing removed.
None		
<i>Supplies</i>	<i>Special Environmental Conditions</i>	
Oil, lubricating, Item 46, Appendix C	None	
Solvent, dry cleaning, Item 57, Appendix C		
<i>Personnel Required</i>	<i>General Safety Instructions</i>	
MOS 63W, Wheel vehicle repairer	None	
	<i>Level of Maintenance</i>	
	General Support	

Transmission Maintenance Instructions (Cont)

a. Removal.

- (1) Remove retaining ring (1).
- (2) Remove seven steel plates (2) and six friction plates (3) from transmission housing (4).

NOTE

Some clutch assemblies contain paper friction plates. Discard all paper friction plates. They are replaced by graphite friction plates.

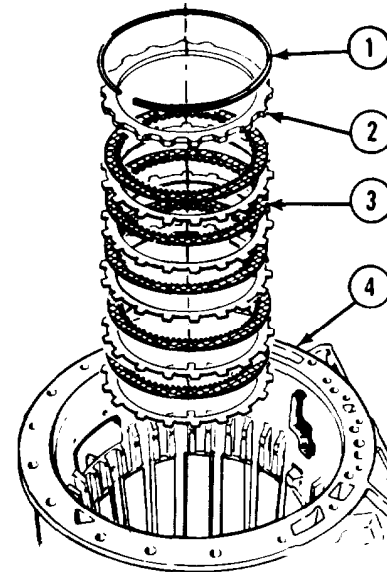

b. Disassembly.

- (1) Remove second clutch piston (1) from bottom of center support housing (2).
- (2) Remove outer seal ring (3) and inner seal ring (4) from second clutch piston (1).

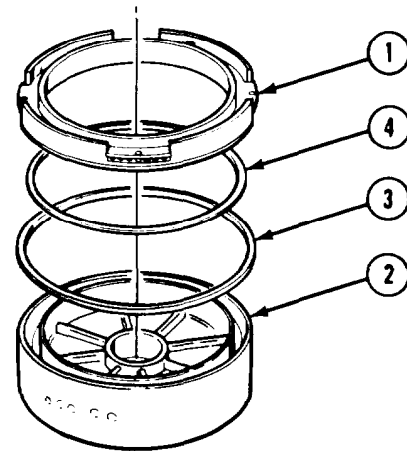

Transmission Maintenance Instructions (Cont)

7-19. SECOND CLUTCH AND CENTER SUPPORT HOUSING REMOVAL/REPAIR/INSTALLATION (CONT).

- (3) Cut and remove four retaining rings (5).
- (4) Remove clutch ring (6) from second clutch piston (1).
- (5) Remove 20 springs (7) from second clutch piston (1).

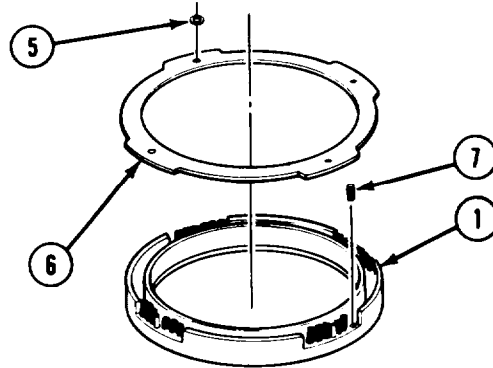

c. Cleaning/Inspection.

WARNING

Adhesives, solvents, and sealing compounds can burn easily, can give off harmful vapors, and are harmful to skin and clothing. To avoid injury or death, keep away from open fire and use in well-ventilated area. If adhesive, solvent, or sealing compound gets on skin or clothing, wash immediately with soap and water.

- (1) Clean all metallic parts with drycleaning solvent and inspect for damage. Replace damaged parts.
- (2) Replace piston release springs if any three in each set of 20 do not meet the following load-height requirements:
 - (a) Length without load must be at least 1.29 in. (32.8 mm).
 - (b) Length under load must be at least 0.82 in. (20.8 mm) with load of 4.3 to 5.7 lb-ft (19.1 to 25.4N).

d. Assembly.

- (1) Set second clutch piston (1) in rear cavity of center support housing (2).
- (2) Install 20 piston release springs (3) in second clutch piston (1).
- (3) Install clutch ring (4) on second clutch piston (1).

CAUTION

Clutch ring must be pushed completely down in center support housing while installing retaining rings or clutch clearance will be wrong.

- (4) Install four retaining rings (5). Remove second clutch piston (1) from center support housing (2).

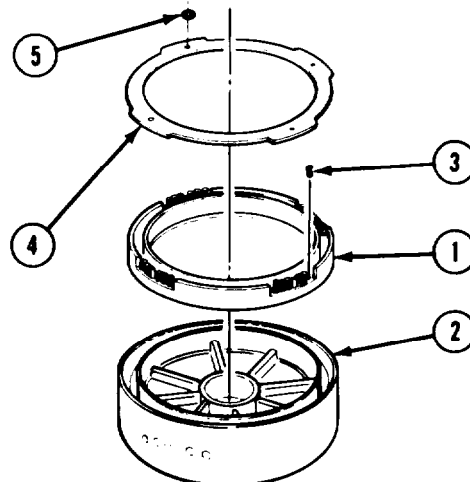

Transmission Maintenance Instructions (Cont)

NOTE

Some clutch assemblies contain paper friction plates. When servicing clutch assembly, replace all paper friction plates with graphite friction plates. Paper friction plates and graphite friction plates cannot be intermixed within the same clutch assembly. Refer to TM 9-2320-279-24P for identification of parts.

- (5) Stack 13 clutch plates (6 and 7) on flat surface of press, starting with steel plate (6) and alternating with friction plate (7).
- (6) Place second clutch piston (1) on top of clutch plates (6 and 7).
- (7) Press evenly on second clutch piston (1) with 980 to 1020 lb load (4359 to 4536.9 N).
- (8) Measure distance from base of clutch pack (8) to top of thrust pad (9).
- (9) Clutch pack thickness must be 3.136 to 3.168 in. (79.66 to 80.48 mm). Replace clutch plates (6 and 7) as needed to ensure proper clutch pack thickness.
- (10) Measure thickness of one tang (10) on each of seven steel plates (6).
 - (a) If steel plate measures 0.116 to 0.123 in. (2.95 to 3.12 mm), steel plate is thick.
 - (b) If steel plate measures 0.099 to 0.106 in. (2.51 to 2.69 mm), steel plate is thin.
- (11) Repeat steps (5) through (9) to recheck clutch pack thickness.
- (12) Remove clutch pack (8) from press.
- (13) Apply lubricating oil to inner seal ring (11) and outer seal ring (12) and install inner seal ring and outer seal ring on second clutch piston (1) with lips facing down.

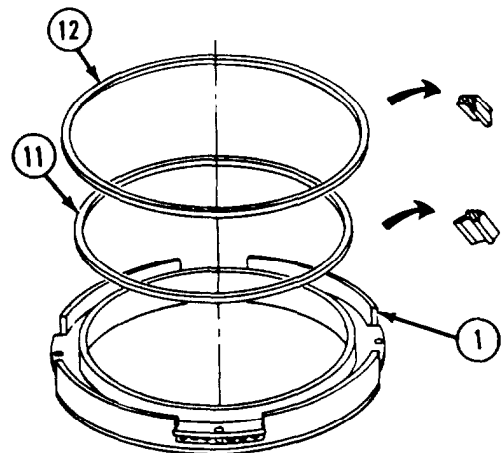
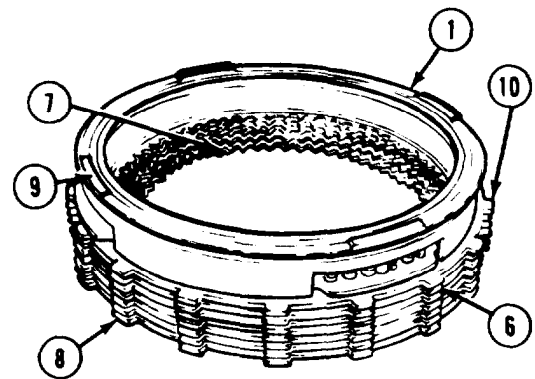
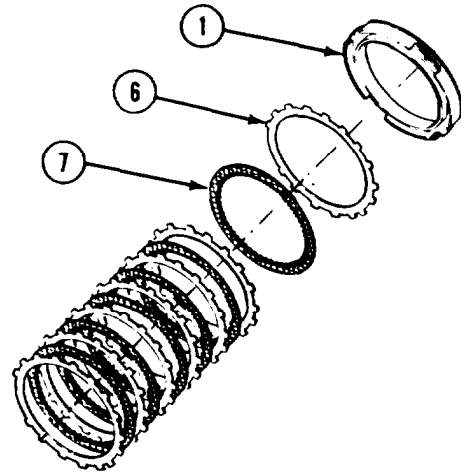

Transmission Maintenance Instructions (Cont)

**7-19. SECOND CLUTCH AND CENTER SUPPORT HOUSING
REMOVAL/REPAIR/INSTALLATION (CONT).**

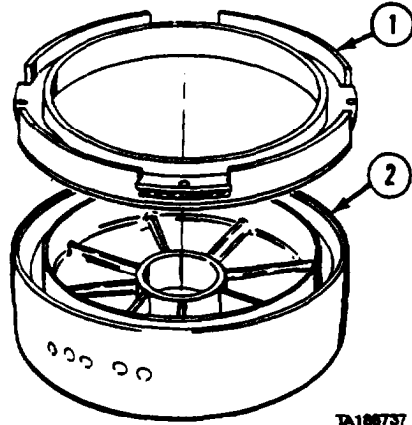

TA168737

(14) Install second clutch piston (1) in bottom of center support housing (2).

e. Installation.

- (1) Soak six friction plates (1) in oil for 2 minutes.

NOTE

Thick steel plates must be installed on top of stack.

- (2) install steel plates (2) with gap (3) facing as shown.
- (3) Install 12 clutch plates (1 and 2), starting with friction plate (1) and alternating with steel Plate (2).
- (4) install retaining ring (4) with gap opposite oil pan side (5) of transmission housing (6).

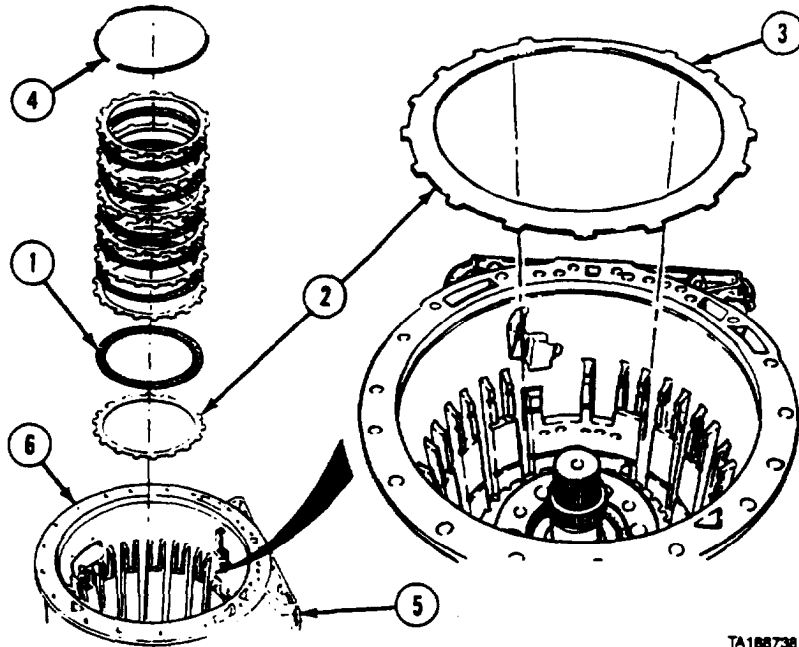

TA168738

f. Follow-on Maintenance. Install third clutch and center support housing (para 7-18).

END OF TASK

Transmission Maintenance Instructions (Cont)

Section VIII. VALVE BODIES AND GOVERNOR

7-20. CONTROL VALVE BODY REMOVAL/REPAIR/INSTALLATION.		
This task covers:		
a. Removal	d. Assembly	
b. Disassembly	e. Installation	
c. Cleaning/Inspection	f. Follow-on Maintenance	
INITIAL SETUP		
<i>Models</i>	<i>References</i>	
All	None	
<i>Test Equipment</i>	<i>Equipment Condition</i>	
None	<i>TM or Para</i>	<i>Condition Description</i>
<i>Special Tools</i>	Para 7-21	Modulator valve removed.
None	Para 7-22	Lockup cutoff valve body removed.
<i>Supplies</i>	<i>Special Environmental Conditions</i>	
Oil, lubricating, Item 46, Appendix C	None	
Solvent, dry cleaning, Item 57, Appendix C	<i>General Safety Instructions</i>	
Tags, identification, Item 60, Appendix C	None	
<i>Personnel Required</i>	<i>Level of Maintenance</i>	
MOS 63W, Wheel vehicle repairer (2)	General Support	

a. Removal.

CAUTION

Be sure forward clutch is secured before turning transmission. Clutch could fall and be damaged if not secured.

- (1) Turn transmission (1) so control valve body (2) is up.
- (2) Remove two screws (3) and oil baffle (4).
- (3) Remove screw (5) and manual detent lever (6).
- (4) Remove 15 screws (7), seven screws (8), three screws (9), two screws (10), and two washers (11).
- (5) While holding selector valve (12), remove control valve body (2) from transmission housing (1).

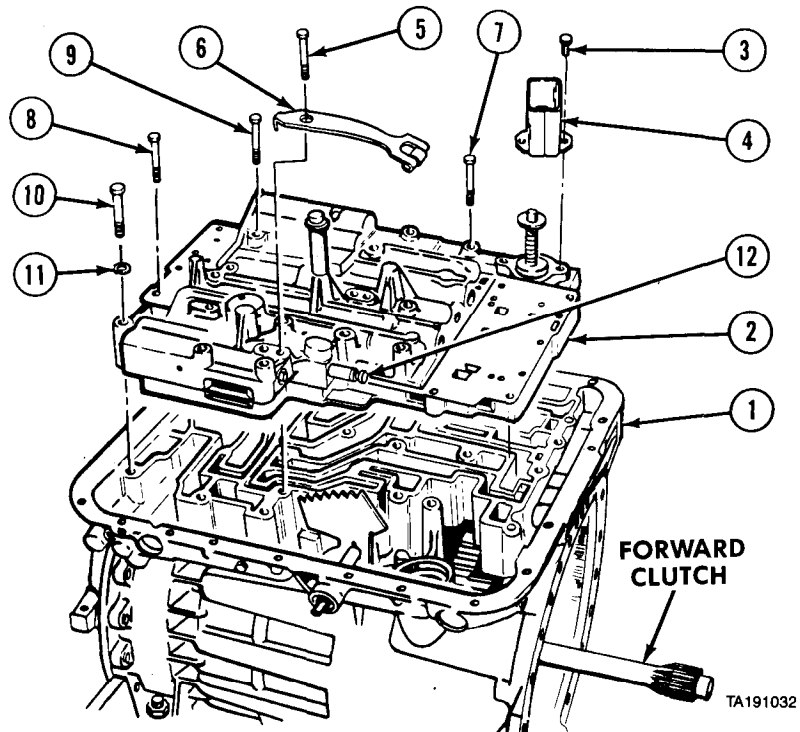

Transmission Maintenance Instructions (Cont)

7-20. CONTROL VALVE BODY REMOVAL/REPAIR/INSTALLATION (CONT).

b. Disassembly.

- (1) Remove three screws (1) from modulator valve body (2).
- (2) Remove modulator valve body (2) while holding oil transfer plate (3) and separator plate (4) together.

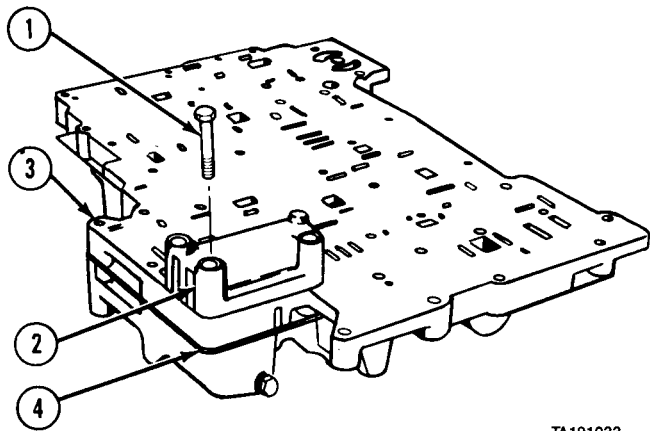

TA191033

NOTE

Turn transfer plate and separator plate over before placing on work surface.

- (3) Hold oil transfer plate (3) and separator plate (4) together and remove from control valve body (5).

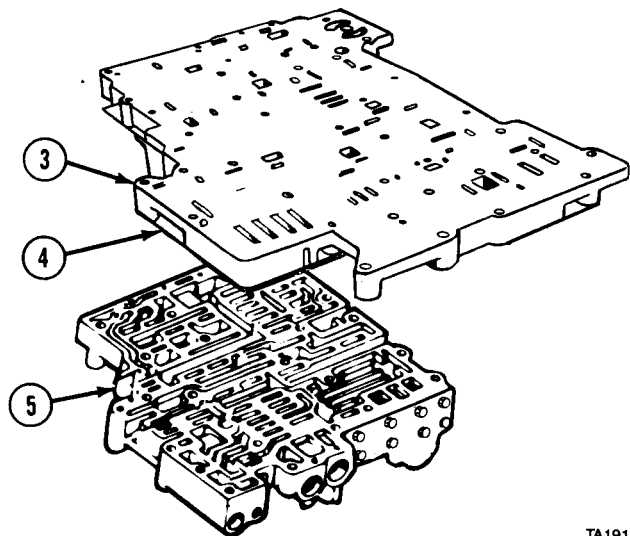

TA191034

- (4) Lift separator plate (4) from oil transfer plate (3).

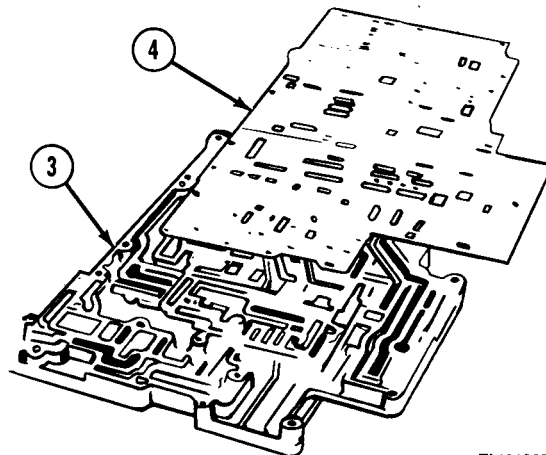

TA191035

Transmission Maintenance Instructions (Cont)

NOTE

Record and identify check balls by size and location.

- (5) Remove check balls (6, 7, 8, 9, and 10).
- (6) Soldier A removes retaining pin (11) from check valve pin (12) while Soldier B presses down on cup washer (13).
- (7) Remove cup washer (13), spring (14), lubrication check valve (15) and check valve pin (12) from oil transfer plate (3).

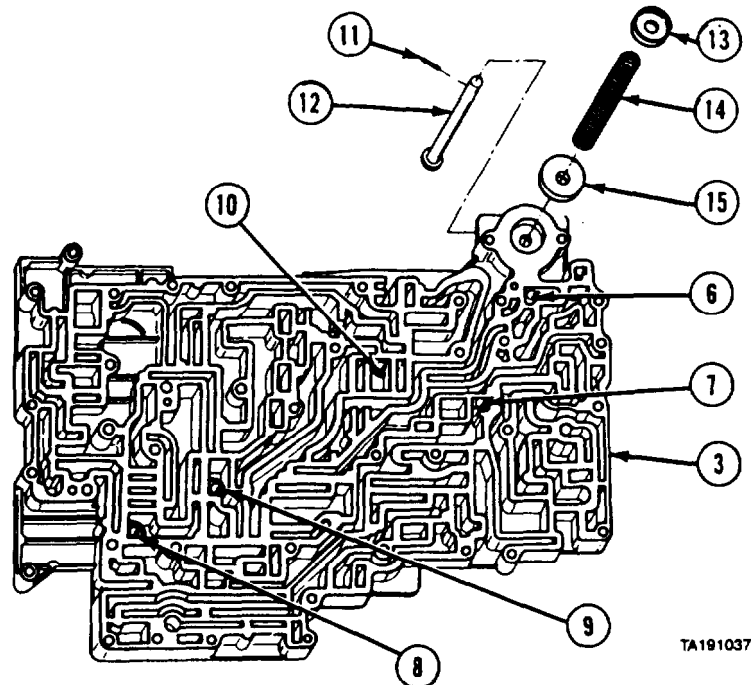

TA191037

WARNING

All valves are under spring tension. Release springs slowly to avoid personal injury.

CAUTION

Do not use magnets to remove valve bodies. Magnetized valve bodies may not work properly.

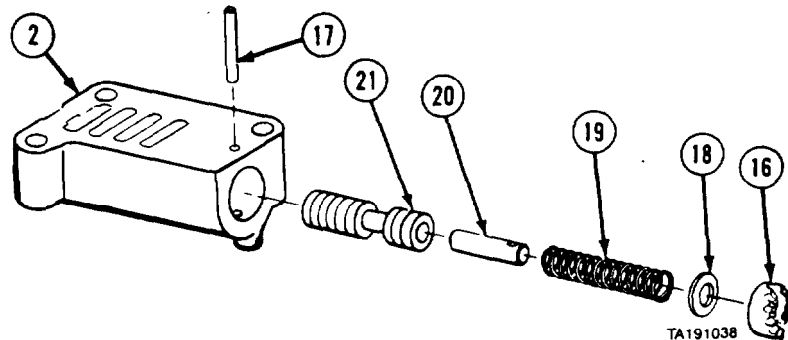

TA191038

NOTE

- Tag and mark all parts before removing.
 - Record each notch on adjusting ring that touches retaining pin.
- (8) Press adjusting ring (16) inward and remove retaining pin (17) from modulator valve body (2).
 - (9) Remove adjusting ring (16), washer (18), spring (19), valve stop (20) and valve (21) from modulator valve body (2).

Transmission Maintenance Instructions (Cont)

7-20. CONTROL VALVE BODY REMOVAL/REPAIR/INSTALLATION (CONT).

- (10) Remove priority valve (22), spring (23), and valve stop (24) from control valve body (5).
- (11) Remove six screws (25).
- (12) Remove last two screws (25) evenly while holding down trimmer valve cover (26). Remove trimmer valve cover.
- (13) Remove plug (27) and governor screen assembly (28) from control valve body (5).

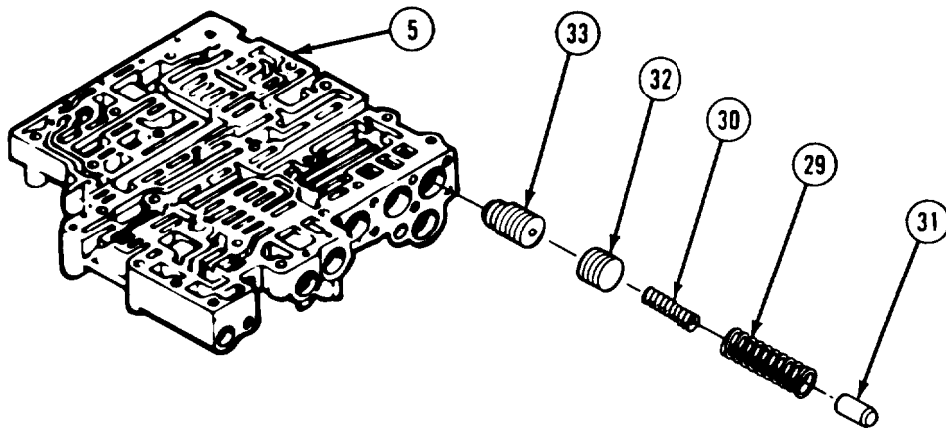
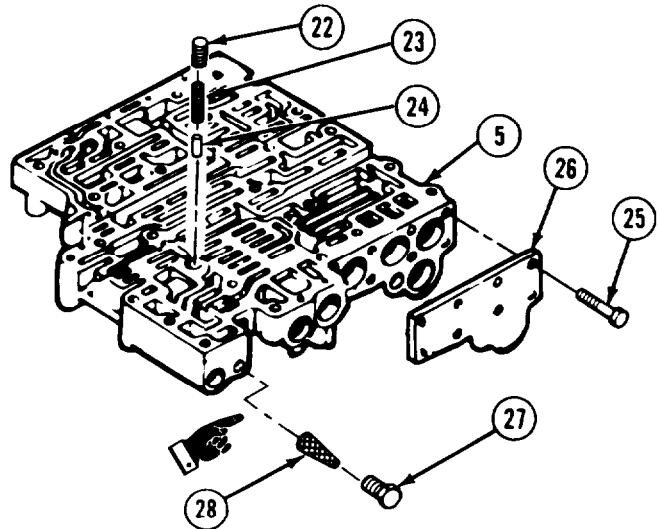

- (14) Remove two springs (29 and 30), valve stop (31), trimmer plug (32), and third clutch trimmer valve (33) from control valve body (5).

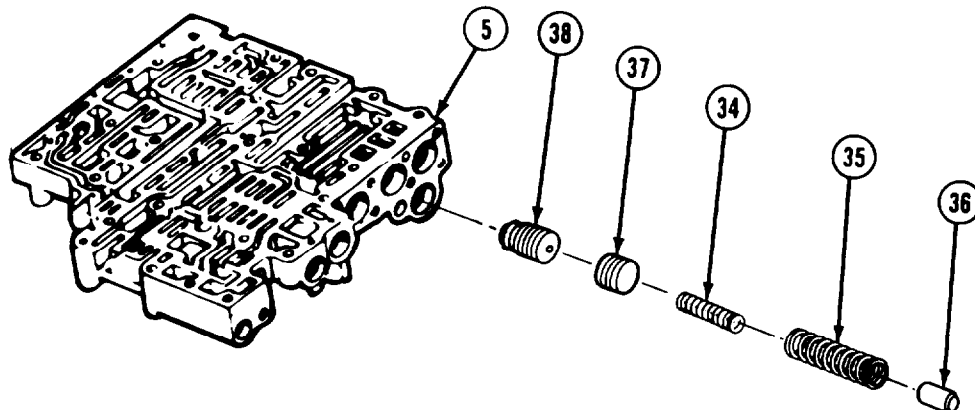

- (15) Remove two springs (34 and 35), valve stop (36), plug (37), and first clutch trimmer valve (38) from control valve body (5).

Transmission Maintenance Instructions (Cont)

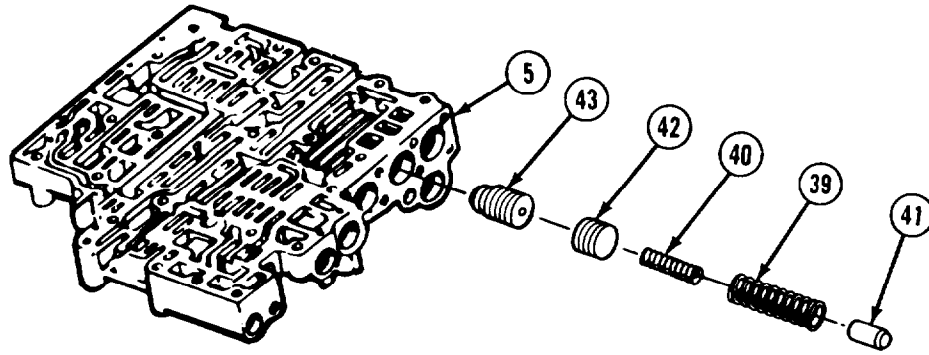

- (16) Remove two springs (39 and 40), valve stop (41), plug (42), and second clutch trimmer valve (43) from control valve body (5).

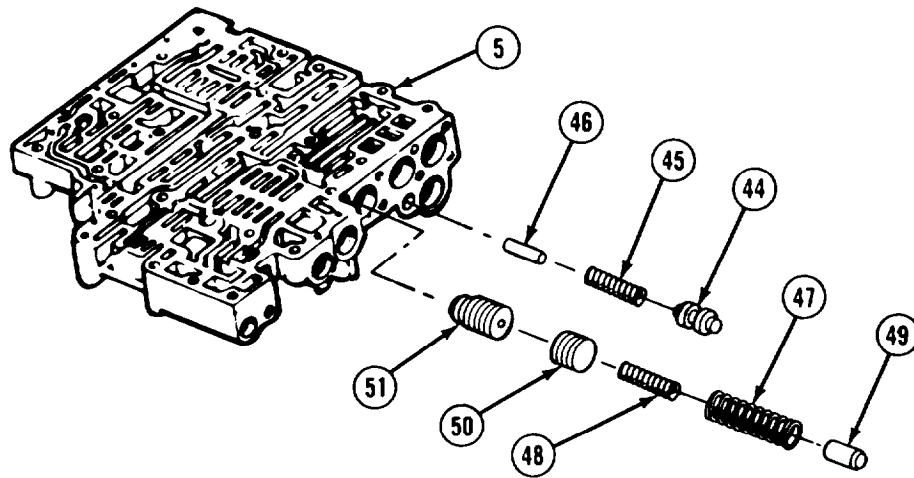

- (17) Remove accumulator valve (44), spring (45), and valve stop (46).
- (18) Remove two springs (47 and 48), valve stop (49), plug (50), and fourth clutch trimmer valve (51) from control valve body (5).
- (19) Remove retaining pin (52), valve stop (53), spring (54), and two-three relay valve (55) from control valve body (5).

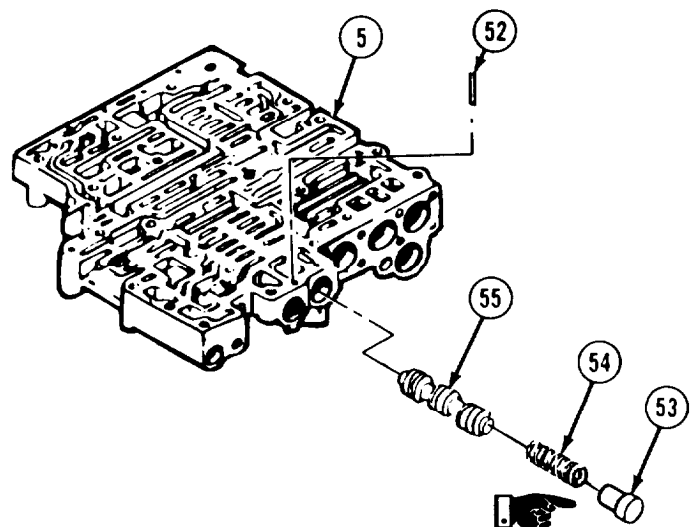

Transmission Maintenance Instructions (Cont)

7-20. CONTROL VALVE BODY REMOVAL/REPAIR/INSTALLATION (CONT).

(20) Remove retainer pin (56), spring spacer (57), spring (58), and one-two , relay valve (59).

(21) Remove retaining pin (60), spring (61), valve stop (62), and accumulator valve (63).

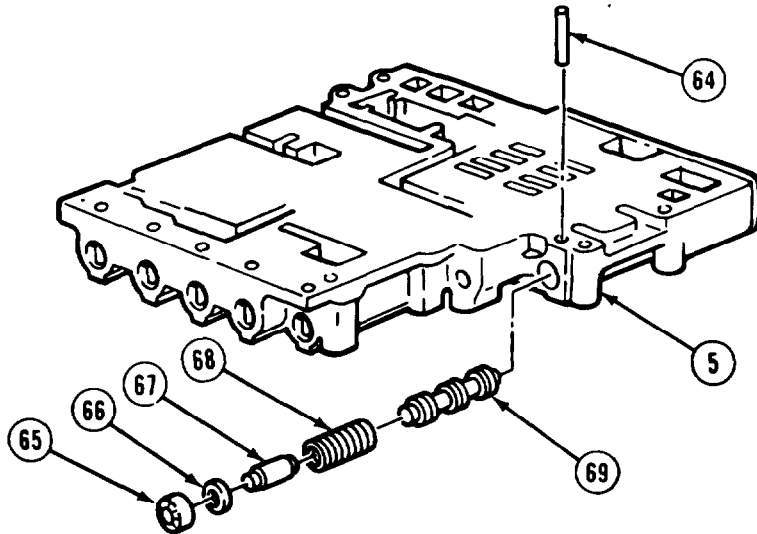
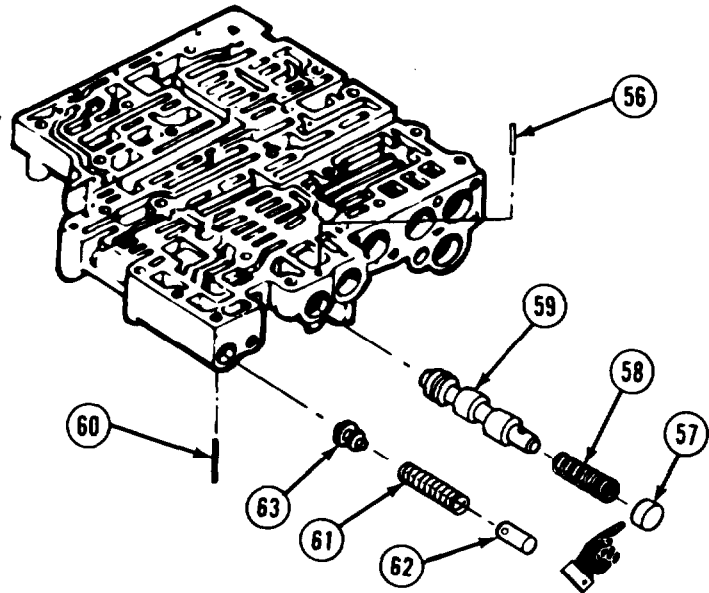

NOTE

Record each notch on adjusting rings that touch retaining pins.

(22) Remove retaining pin (64), adjusting ring (65), washer (66), valve stop (67), valve spring (68), and regulator valve (69) from control valve body (5).

Transmission Maintenance Instructions (Cont)

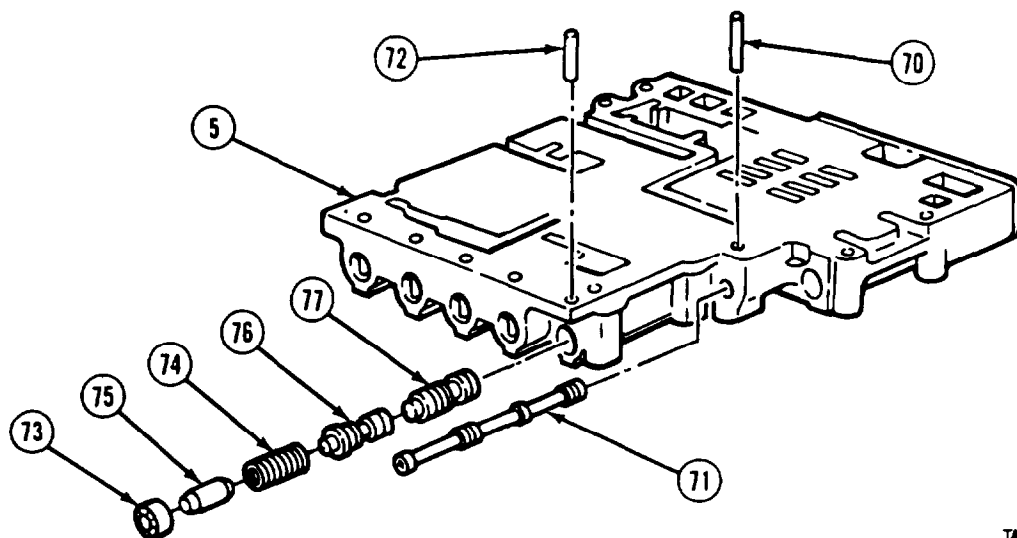

TA191048

- (23) Remove retaining pin (70) and selector valve (71).
 (24) Remove retaining pin (72), adjusting ring (73) valve spring (74) valve stop (75) one-two modulator valve (76), and one-two shift valve (77) from control valve body (5).

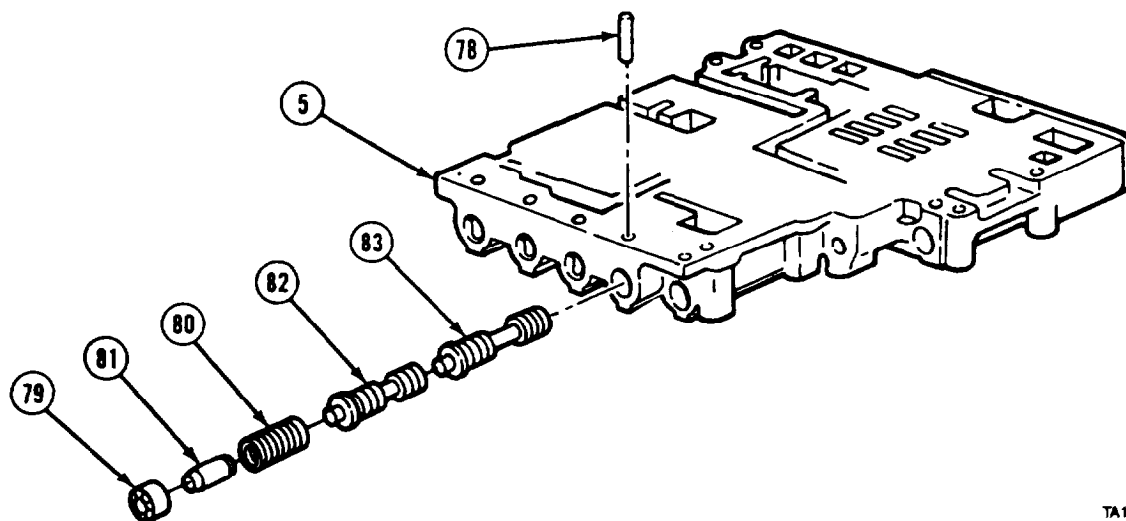

TA191049

- (25) Remove retaining pin (78) adjusting ring (79), valve spring (80) valve stop (81), two-three modulator valve (82), and two-three shift valve (83) from control valve body (5).

Transmission Maintenance Instructions (Cont)

7-20. CONTROL VALVE BODY REMOVAL/REPAIR/INSTALLATION (CONT).

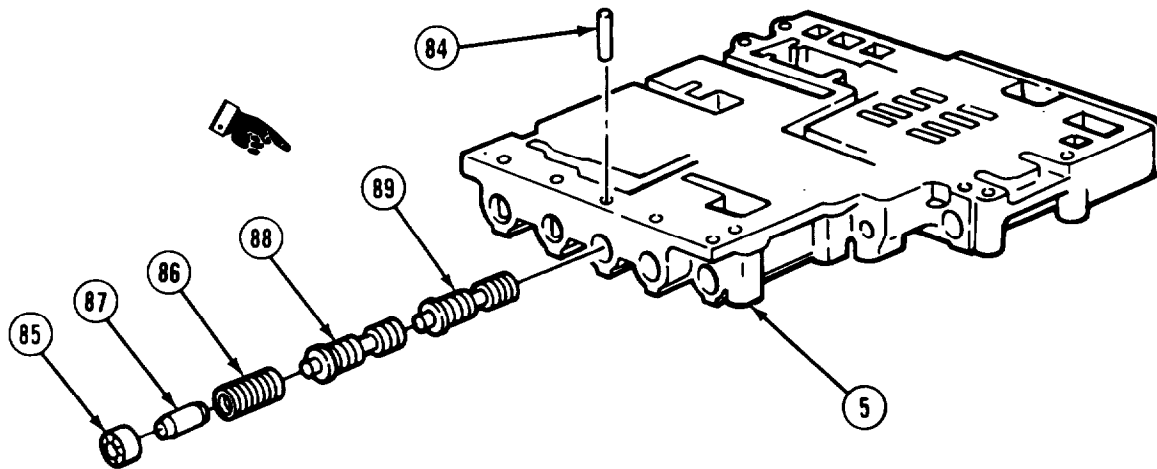

- (26) Remove retaining pin (84), adjusting ring (85), valve spring (86), valve stop (87), three-four modulator valve (88), and three-four shift valve (89) from control valve body (5).

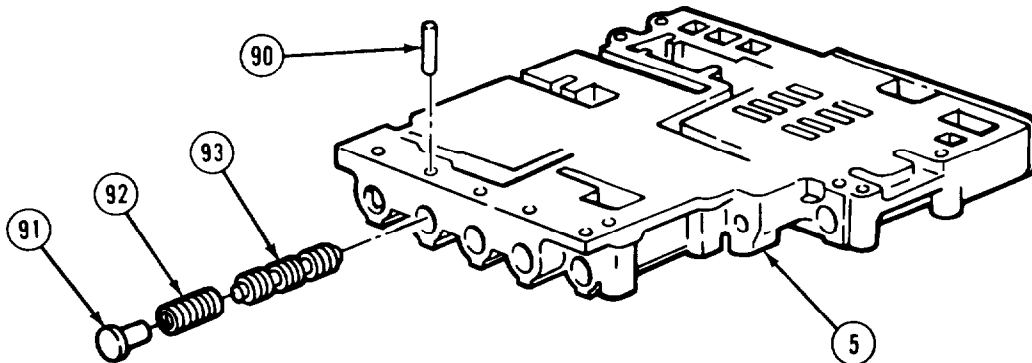

- (27) Remove retaining pin (90), valve stop (91), valve spring (92), and three-four relay valve (93) from control valve body (5).

Transmission Maintenance Instructions (Cont)

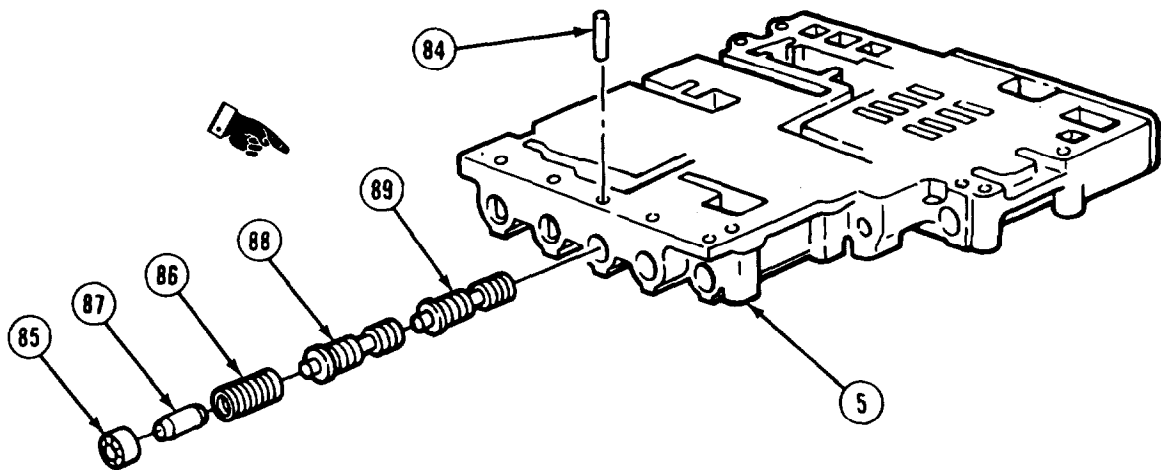

- (28) Remove retaining pin (94), valve stop (95), valve spring (96), and trimmer regulator valve (97) from control valve body (5).

c. Cleaning/Inspection.

WARNING

Adhesives, solvents, and sealing compounds can burn easily, can give off harmful vapors, and are harmful to skin and clothing. To avoid injury or death, keep away from open fire and use in well-ventilated area. If adhesive, solvent, or sealing compound gets on skin or clothing, wash immediately with soap and water.

- (1) Clean all metallic parts with drycleaning solvent.
- (2) Inspect all valves, valve stops, and plugs for damage. Replace damaged parts.
- (3) Inspect bores and surfaces of control valve body for damage.
- (4) Replace springs which do not meet load-length specifications listed in Table 7-2.

Table 7-2. Spring Load-Length Specifications

Spring	Length Without Load in. (mm)	Length Under Load in. (mm)	Load lb (N)	Text Step No.	Reference Callout No.
Lubrication check valve	2.56 (65.0)	1.97 (50.0)	35.72 to 39.48 (158.9 to 175.6)	(7)	(14)
Modulator valve	1.47 (37.3)	0.80 (20.3)	11.9 to 13.1 (52.9 to 58.3)	(9)	(19)
Priority valve	1.17 (29.7)	0.94 (23.9)	8.15 to 9.25 (36.3 to 41.2)	(10)	(23)
Third clutch trimmer valve (primary)	2.27 (57.7)	1.94 (49.3)	9.4 to 11.4 (41.8 to 50.7)	(14)	(29)
Third clutch trimmer valve (secondary)	1.45 (36.8)	1.10 (27.9)	20.7 to 25.3 (92.52 to 112.5)	(14)	(30)
First clutch trimmer valve (secondary)	1.69 (42.9)	1.10 (27.9)	32.6 to 39.8 (145.0 to 177.0)	(15)	(34)
First clutch trimmer valve (primary)	2.96 (75.2)	1.10 (27.9)	15.95 to 17.65 (70.9 to 78.5)	(15)	(35)
Second clutch trimmer valve (secondary)	1.95 (49.5)	1.10 (27.9)	29.0 to 35.4 (128.9 to 157.5)	(16)	(40)

Transmission Maintenance Instructions (Cont)

7-20. CONTROL VALVE BODY REMOVAL/REPAIR/INSTALLATION (CONT).*Table 7-2. Spring Load-Length Specifications (Cont)*

Spring	Length Without Load in. (mm)	Length Under Load in. (mm)	Load lb (N)	Text Step No.	Reference Callout No.
Second clutch trimmer valve (primary)	2.56 (65.0)	1.94 (49.3)	20 to 22 (89.0 to 97.9)	(16)	(39)
Accumulator valve	2.77 (70.4)	1.49 (37.9)	11.6 to 12.8 (51.6 to 56.9)	(17)	(45)
Fourth clutch trimmer valve (secondary)	1.45 (36.8)	1.10 (27.9)	21.7 to 25.3 (96.6 to 112.6)	(18)	(48)
Fourth clutch trimmer valve (primary)	2.27 (57.7)	1.94 (49.3)	9.4 to 11.4 (41.8 to 50.7)	(18)	(47)
2-3 Relay valve	2.18 (55.4)	1.20 (30.5)	16.2 to 19.8 (72.1 to 88.1)	(19)	(58)
1-2 Relay valve	1.52 (38.6)	1.10 (28.0)	7.2 to 6.8 (32.0 to 39.1)	(20)	(54)
Governor accumulator valve	1.84 (46.7)	(17.8)	9.6 to 10.6 (42.7 to 47.2)	(21)	(61)
Regulator valve	1.68 (42.7)	1.15 (29.2)	5.14 to 5.36 (22.9 to 23.8)	(22)	(68)
1-2 Shift valve	2.65 (67.3)	1.15 (29.2)	8.65 to 9.35 (38.5 to 41.6)	(24)	(74)
2-3 Shift valve	2.51 (63.8)	1.15 (29.2)	10.75 to 11.25 (14.6 to 15.3)	(25)	(80)
3-4 Shift valve	2.69 (68.3)	1.15 (29.2)	8.9 to 9.6 (12.1 to 13.0)	(26)	(86)
3-4 Relay valve	2.18 (55.4)	1.20 (30.5)	16.2 to 19.8 (72.1 to 88.1)	(27)	(92)
Trimmer regulator valve	1.33 (33.78)	0.86 (21.84)	2.3 to 2.54 (10.2 to 11.3)	(28)	(96)

Transmission Maintenance Instructions (Cont)

d. Assembly.

- (1) Place control valve body (1) with flat side up.
- (2) Install one-two relay valve (2), spring (3), and spring spacer (4) in bore of control valve body (1).
- (3) Press spring spacer (4) and install retaining pin (5) in control valve body (1).

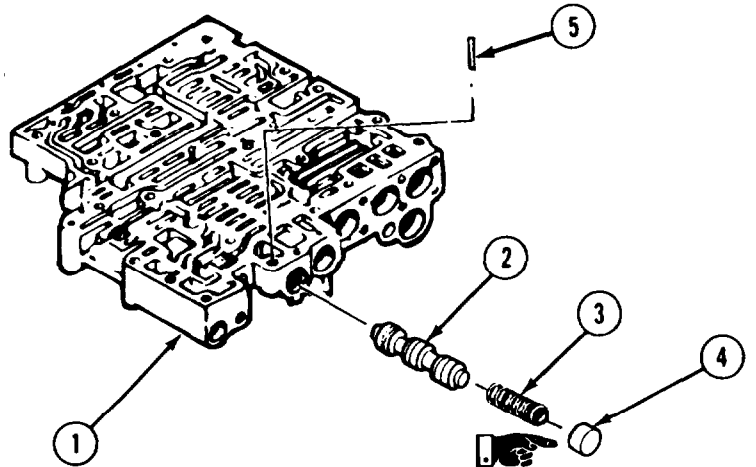

- (4) Install two-three relay valve (6), spring (7), and valve stop (8) in control valve body (1).
- (5) Press valve stop (8) and install retainer pin (9) in control valve body (1).

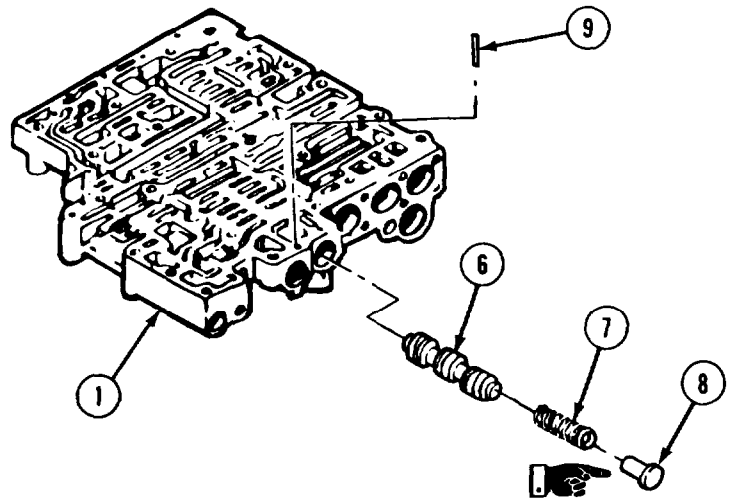

NOTE

Install four clutch trimmer valves with small end first.

- (6) Install fourth clutch trimmer valve (10), plug (11), spring (12) spring (13), and valve stop (14).
- (7) Install second clutch trimmer valve (15), plug (16), spring (17), spring (18), and valve stop (19) in control valve body (1).

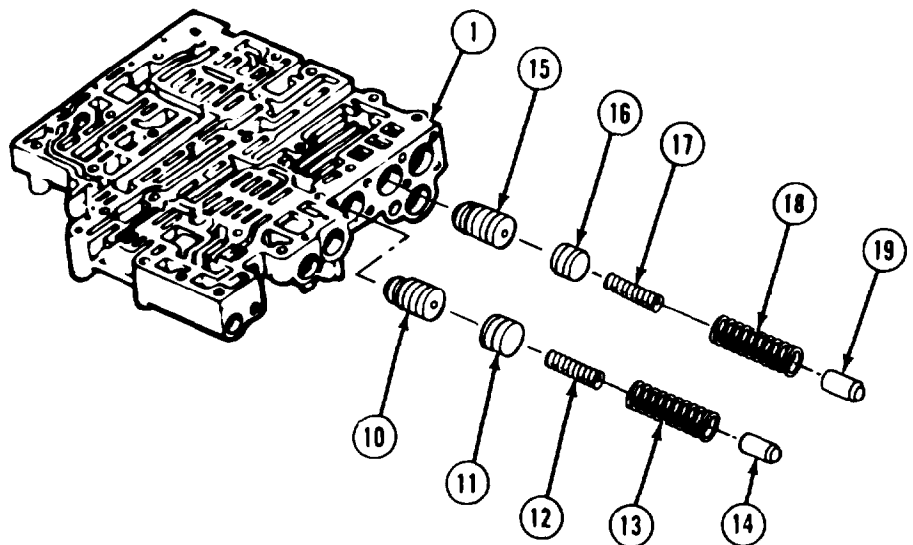

Transmission Maintenance Instructions (Cont)

7-20. CONTROL VALVE BODY REMOVAL/REPAIR/INSTALLATION (CONT).

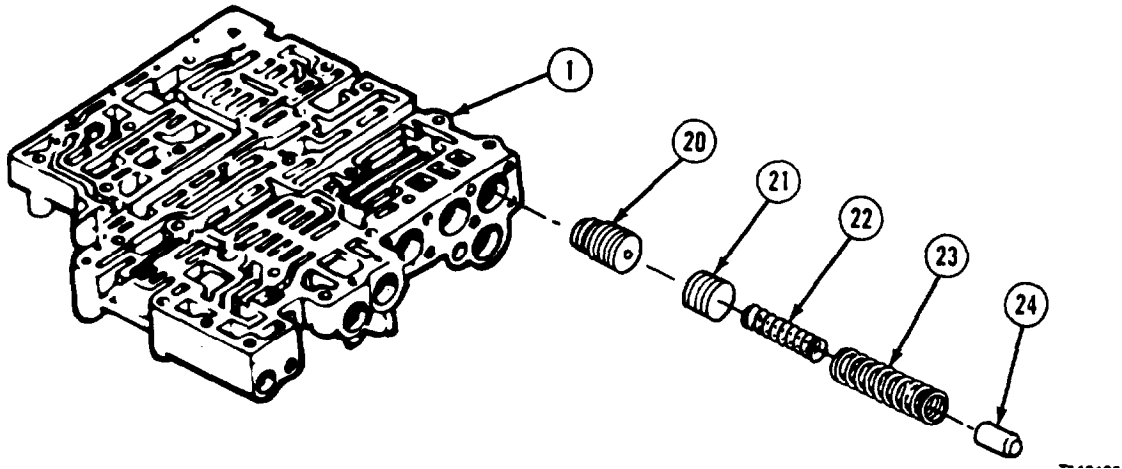

(8) Install third clutch trimmer valve (20), plug (21), spring (22), spring (23), and valve stop (24) in control valve body (1).

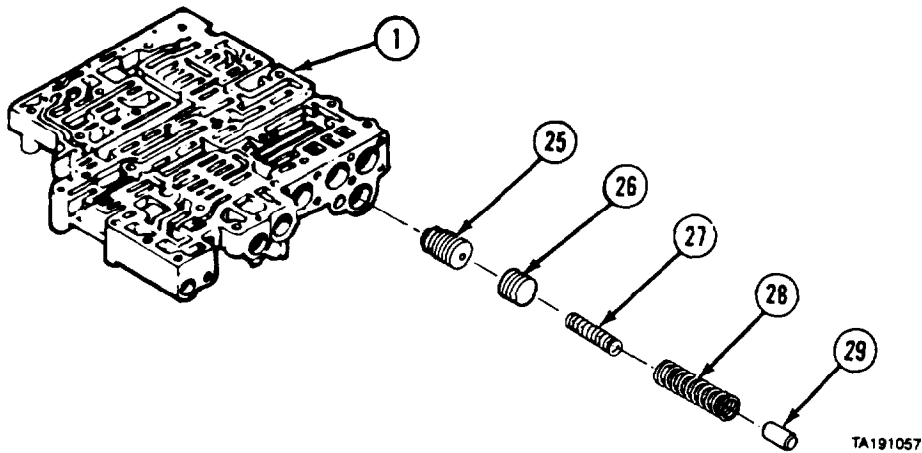

(9) Install first clutch trimmer valve (25), plug (26), secondary spring (27), primary spring (28), and valve stop (29) in control valve body (1).

(10) Install valve stop (30), spring (31), and accumulator valve (32) in control valve body (1).

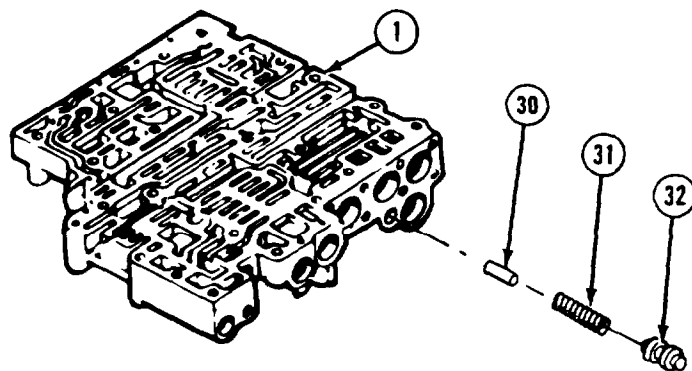

Transmission Maintenance Instructions (Cont)

- (11) Install trimmer valve cover (33) and eight screws (34) while pressing on springs. Tighten screws to 8 to 12 lb-ft (11 to 16 N•m).

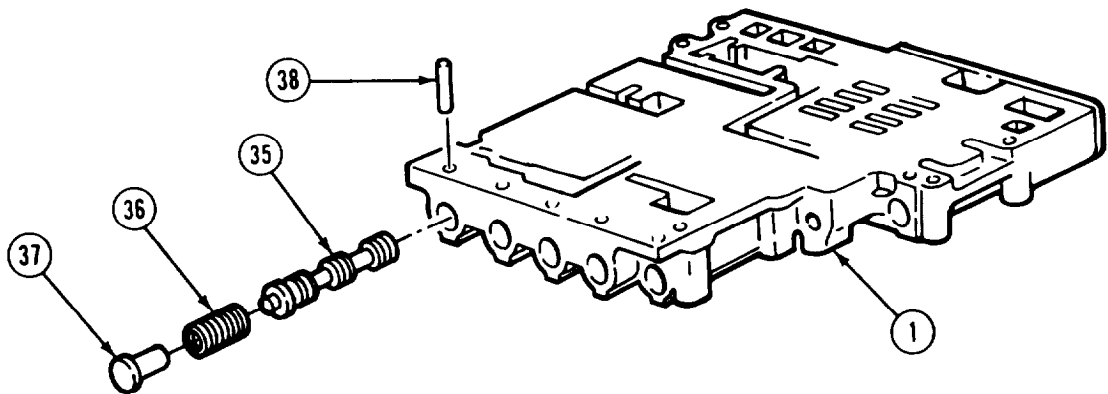
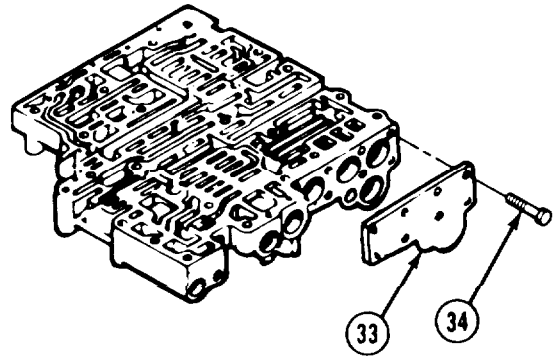

- (12) Install trimmer regulator valve (35), valve spring (36), and valve stop (37) in control valve body (1).
 (13) Press valve stop (37) and install retaining pin (38) in control valve body (1).

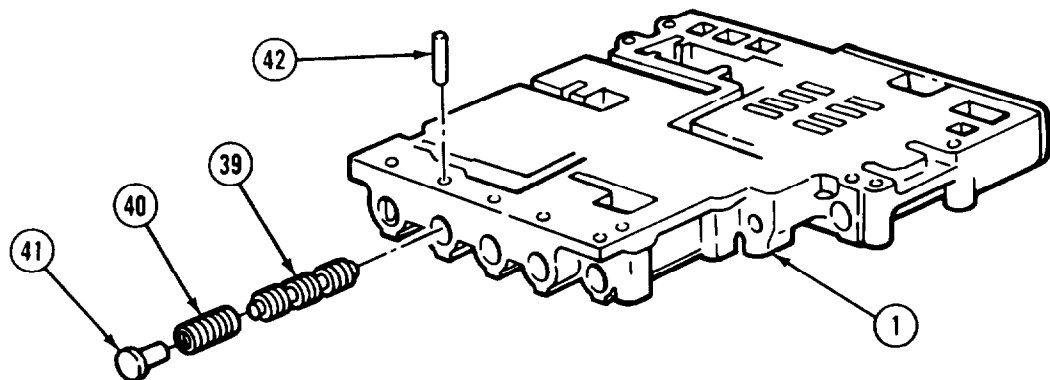

- (14) Install three-four relay valve (39), valve spring (40), and valve stop (41).
 (15) Press valve stop (41) and install retaining pin (42) in control valve body (1).

Transmission Maintenance Instructions (Cont)

17-20. CONTROL VALVE BODY REMOVAL/REPAIR/INSTALLATION (CONT).

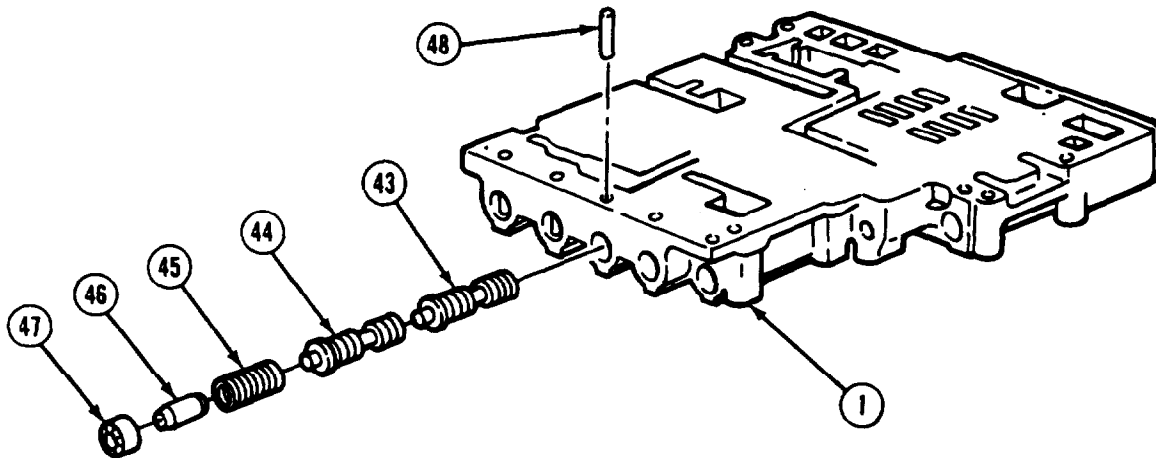

TA191082

- (16) Install three-four shift valve (43), modulator valve (44), valve spring (45), valve stop (46), and adjusting ring (47).
- (17) Aline pinhole in valve stop (46) with pinholes in control valve body (1).
- (18) Press adjusting ring (47) and install retaining pin (48) in control valve body (1).

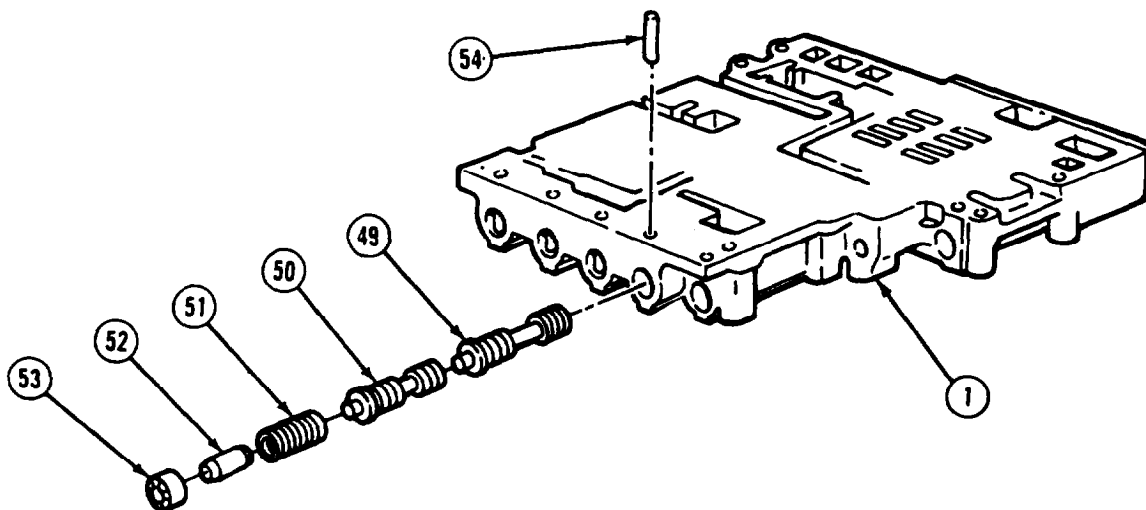

TA191083

- (19) Install two-three shift valve (49), two-three modulator valve (50), valve spring (51), valve stop (52), and adjusting ring (53).
- (20) Aline pinhole in valve stop (52) with pinholes in control valve body (1).
- (21) Press adjusting ring (53) and install retaining pin (54) in control valve body (1).

Transmission Maintenance Instructions (Cont)

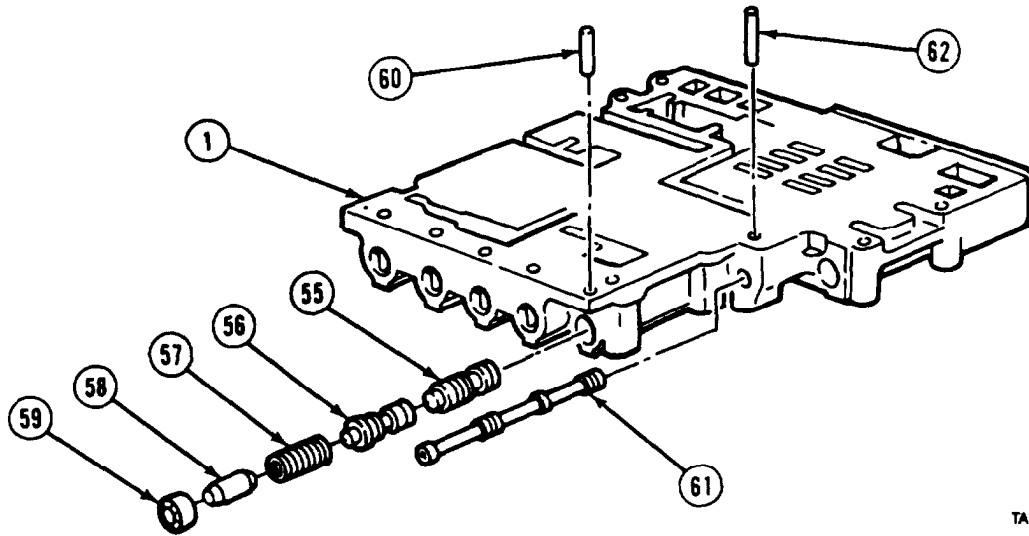

TA191084

- (22) Install one-two shift valve (55), one-two modulator valve (56), spring (57), valve stop (58), and adjusting ring (59).
- (23) Aline pinhole in valve stop (58) with pinholes in control valve body (1).
- (24) Press adjusting ring (59) and install retaining pin (60) in control valve body (1).
- (25) Install selector valve (61).
- (26) Aline pinhole in selector valve (61) with pinhole in control valve body (1).
- (27) Install retaining pin (62) in control valve body (1).

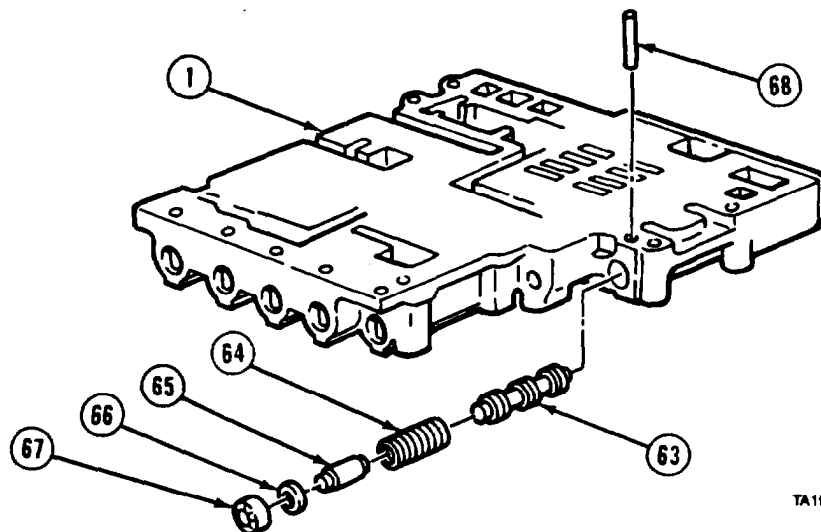

TA191085

- (28) Install regulator valve (63), valve spring (64), valve stop (65), washer (66) and adjusting
- (29) Aline pinhole in valve stop (65) with pinholes in control valve body (1).
- (30) Press adjusting ring (67) and install retaining pin (68) in control valve body (1).

Transmission Maintenance Instructions (Cont)

7-20. CONTROL VALVE BODY REMOVAL/REPAIR/INSTALLATION (CONT).

- (31) Install governor screen assembly (69) and plug (70) in control valve body (1). Tighten plug to 4 to 5 lb-ft (5 to 7 N•m).

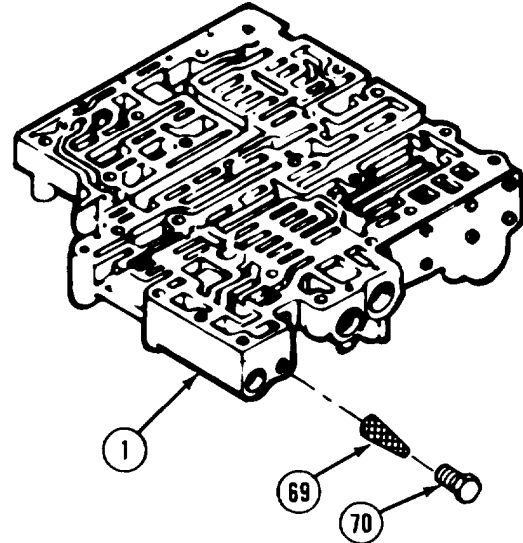

- (32) Install accumulator valve (71), spring (72), and valve stop (73) in control valve body (1).
- (33) Aline pinhole in valve stop (73) with pinholes in control valve body (1).
- (34) Press valve stop (73) and install retaining pin (74) in control valve body (1).
- (35) Install valve stop (75), spring (76), and priority valve (77) in control valve body (1).

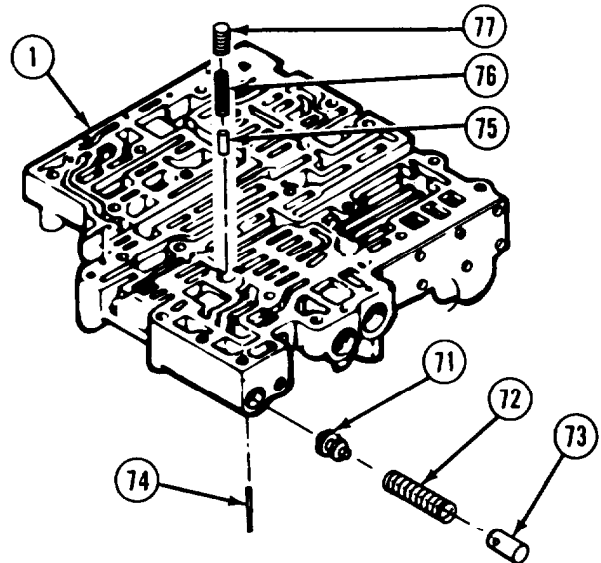

- (36) Install modulator valve (78), valve stop (79), spring (80), washer (81), and adjusting ring (82) in modulator valve body (83).
- (37) Aline pinhole in valve stop (79) with pinholes in modulator valve body (83).

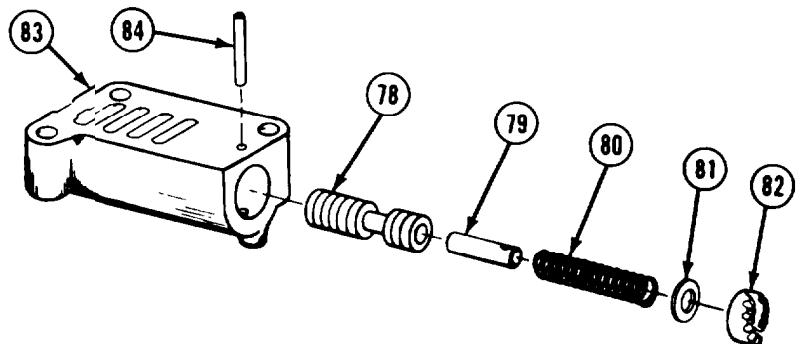

NOTE

Ensure adjusting ring (82) is in same position as before removal.

- (38) Press adjusting ring (82) and install retaining pin (84) in modulator valve body (83).

Transmission Maintenance Instructions (Cont)

- (39) Install check valve pin (85) through top side of oil transfer plate (89).
- (39.1) Install lubrication check valve (86), spring (87), and spring cup washer (88) on oil transfer plate (89) bottom side.
- (40) Soldier A installs retaining pin (90) while Soldier B presses down on spring cup washer (88).
- (41) Install four 0.25 in. (6.4 mm) check balls (91, 93, 94, and 95) and 0.3125 in. (7.94 mm) check ball (92).

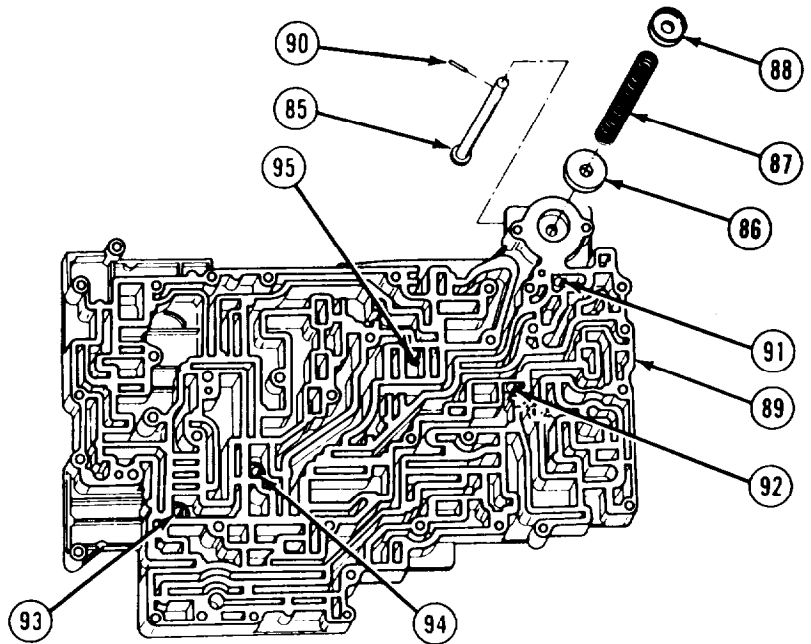

- (42) Slide separator plate (96) on oil transfer plate (89).

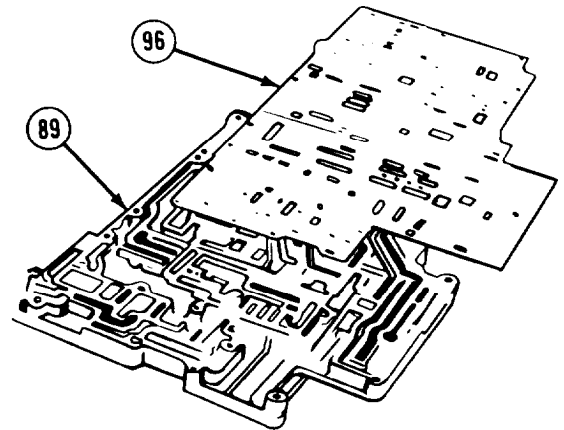

- (43) Hold separator plate (96) and oil transfer plate (89) together, turn plates over, and place on control valve body (1).

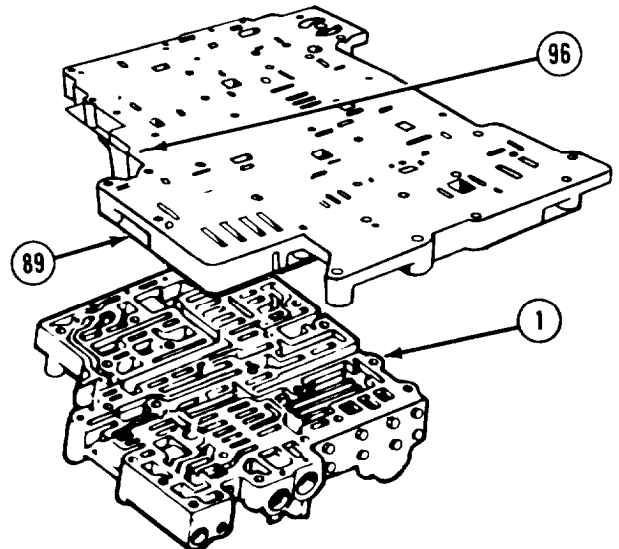

Transmission Maintenance Instructions (Cont)

7-20. CONTROL VALVE BODY REMOVAL/REPAIR/INSTALLATION (CONT).

- (44) Insert six screws (97) through oil transfer plate (89), separator plate (96), and control valve body (1) to aline screw holes.
- (45) Place modulator valve body (83) on oil transfer plate (89) and install three screws (98).
- (46) Tighten screws (98) to 8 to 12 lb-ft (11 to 16 N•m).
- (47) Remove six screws (97).

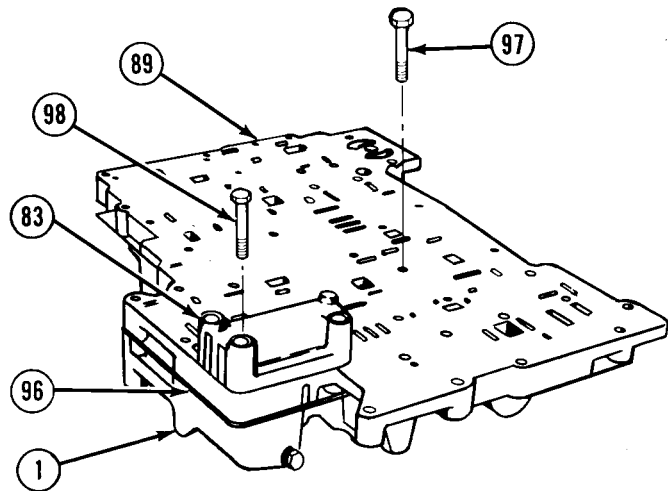

e. Installation.

WARNING

Adhesives, solvents, and sealing compounds can burn easily, can give off harmful vapors, and are harmful to skin and clothing. To avoid injury or death, keep away from open fire and use in well-ventilated area. If adhesive, solvent, or sealing compound gets on skin or clothing, wash immediately with soap and water.

CAUTION

Care must be exercised when grinding the locator boss. The transmission must remain clean and free of contamination. Failure to comply may result in damage to equipment.

NOTE

- If replacing modulator valve body with the manufacturer logo **M**, transmission housings manufactured prior to 1986 may need to be altered.
- Identify transmission housing casting date located on the right or left hand side of the transmission housing.
- If date in casting indicates casting prior to 1986, go to step (1).
- If date in casting indicates casting after 1986, go to step (1.3).
- Transmission housing described above are altered by removing material from the locator boss.

MODULATOR BODY
MANUFACTURER LOGO

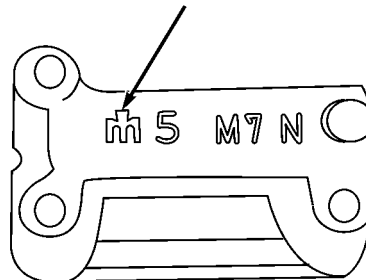

Transmission Maintenance Instructions (Cont)

- (1) Locator boss should be measured from the transmission oil track surface to the top of the locator boss prior to grinding.
- (1.1) Removing material from the housing locator boss to a dimension of 1.500 inches (38 mm) as measured from the transmission housing oil track face will be sufficient to clear the modulator valve body.
- (1.2) Clean all debris from transmission housing oil track with dry cleaning solvent.

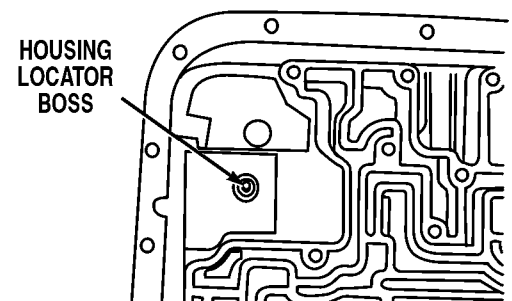
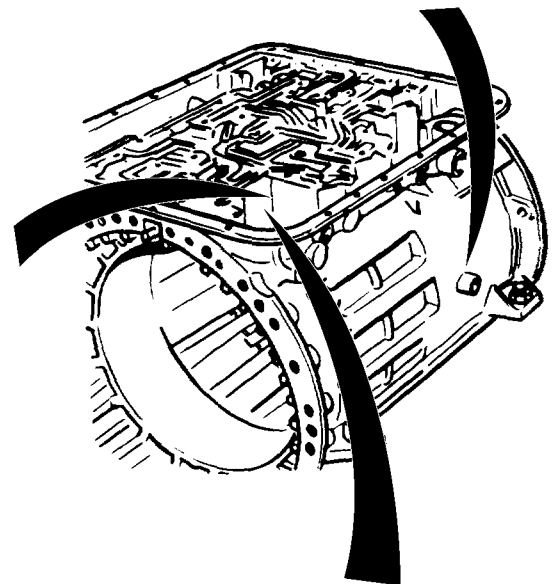
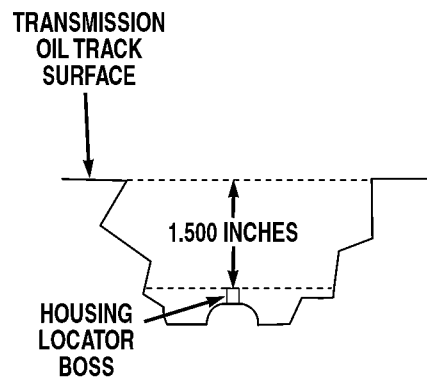
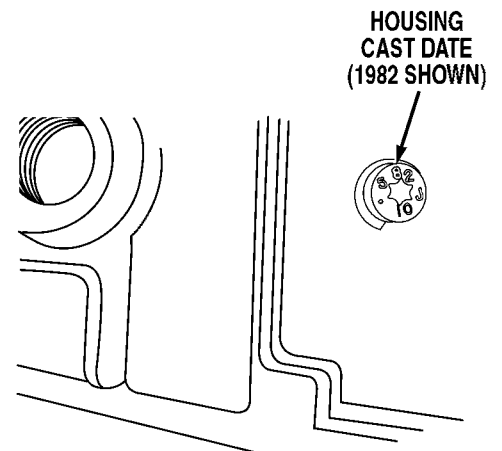

Transmission Maintenance Instructions (Cont)

7-20. CONTROL VALVE BODY REMOVAL/REPAIR/INSTALLATION (CONT).

- (1.3) Install control valve body (1) and transfer plate (2), making sure shift rack pin (3) engages slot on selector valve (4).
- (2) Install three screws (5).
- (3) Install seven screws (6).
- (4) Install two screws (7) and washers (8).
- (5) Install 15 screws (9) in control valve body (1).
- (6) Install manual detent lever (10) and screw (11) in control valve body (1).
- (7) Install oil baffle (12) and two screws (13).
- (8) Tighten screws (5, 6, 7, 9, 11, and 13) to 8 to 12 lb-ft (11 to 16 N•m).

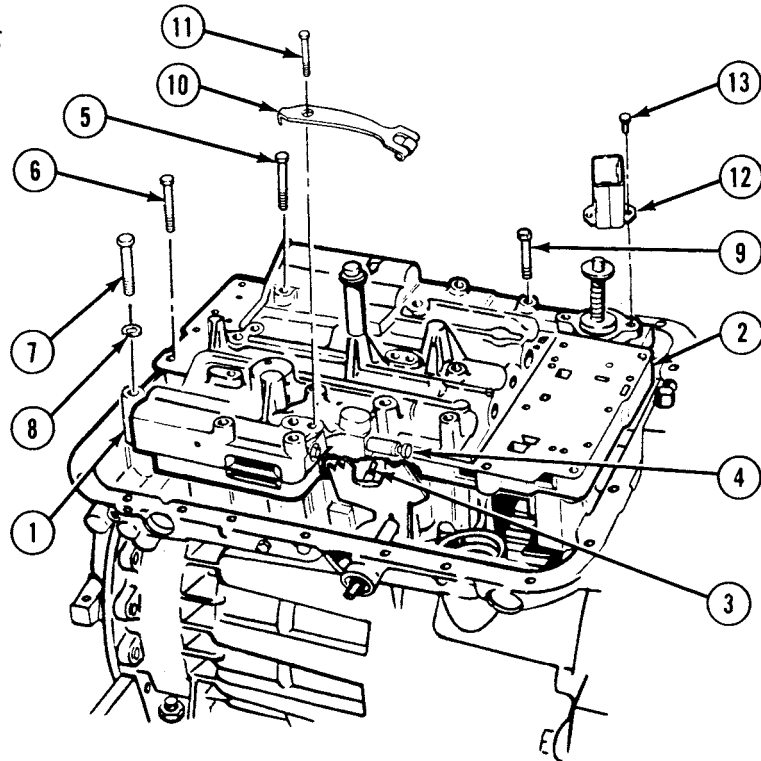

f. Follow-on Maintenance.

- (1) Install lockup cutoff valve body (para 7-22).
- (2) Install modulator valve (para 7-21).

END OF TASK

Transmission Maintenance Instructions (Cont)

7-21. MODULATOR VALVE REMOVAL/INSTALLATION.

This task covers:

- a. Removal
- b. Installation
- c. Follow-on Maintenance

INITIAL SETUP

Models
All

References
None

Test Equipment
None

Equipment Condition
TM or Para Condition Description
TM 9-2320-279-10 Shut off engine.

Special Tools
None

Special Environmental Conditions
None

Supplies
Tags, identification, Item 60, Appendix C

General Safety Instructions
None

Personnel Required
MOS 63W, Wheel vehicle repairer

Level of Maintenance
Direct Support

a. Removal.

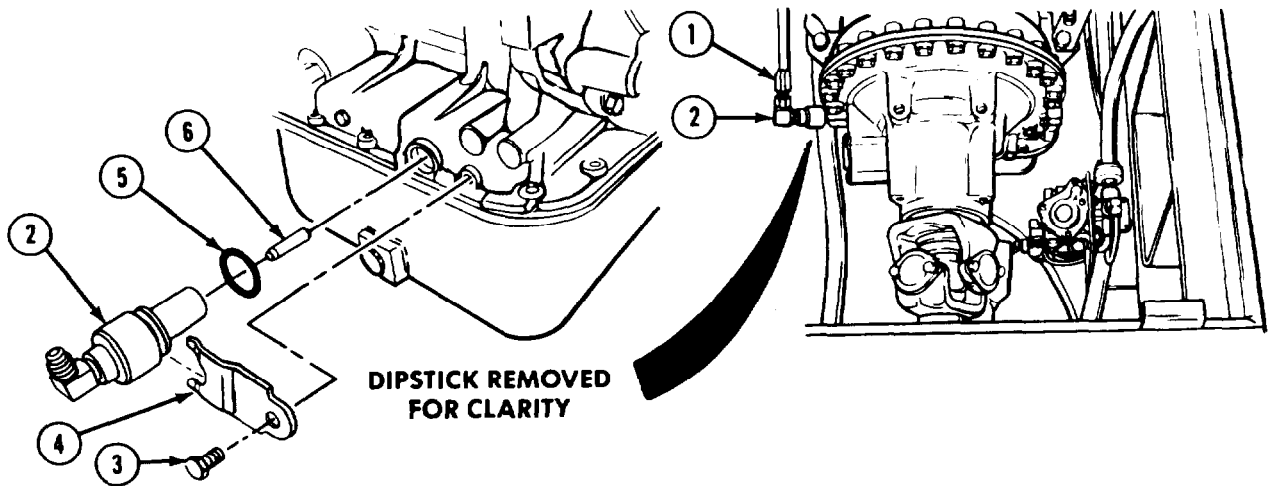

NOTE

Tag and mark hose before disconnecting.

- (1) Disconnect hose (1) from modulator valve (2).
 - (2) Remove screw (3), bracket (4), modulator valve (2), preformed packing (5), and pin (6).
- b. Installation.**
- (1) Install pin (6), preformed packing (5), modulator valve (2), bracket (4), and screw (3).
 - (2) Tighten screw (3) to 10 to 13 lb-ft (14 to 18 N•m).
 - (3) Connect hose (1) to modulator valve (2).

c. Follow-on Maintenance. None.

END OF TASK

Transmission Maintenance Instructions (Cont)

7-22. LOCKUP CUTOFF VALVE BODY REMOVAL/REPAIR/INSTALLATION.		
This task covers:		
a. Removal	d. Assembly	
b. Disassembly	e. Installation	
c. Cleaning/Inspection	f. Follow-on Maintenance	
INITIAL SETUP		
<i>Models</i>	<i>References</i>	
All	None	
<i>Test Equipment</i>	<i>Equipment Condition</i>	
None	<i>TM or Para</i>	<i>Condition Description</i>
<i>Special Tools</i>	Para 7-12	Internal filter element removed.
None	<i>Special Environmental Conditions</i>	
<i>Supplies</i>	None	
Solvent, dry cleaning, Item 57, Appendix C	<i>General Safety Instructions</i>	
Oil, lubricating, Item 46, Appendix C	None	
Tags, identification, Item 60, Appendix C	<i>Level of Maintenance</i>	
Cloth, crocus, Item 16, Appendix C	General Support	
<i>Personnel Required</i>		
MOS 63W, Wheel vehicle repairer		

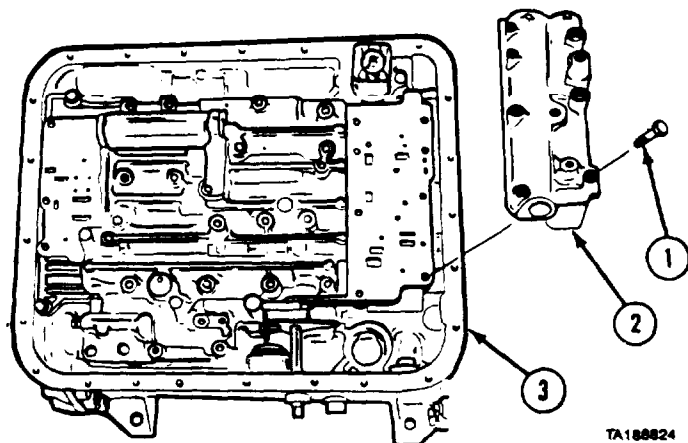

a. Removal. Remove eight screws (1) and valve (2) from transmission (3).

Transmission Maintenance Instructions (Cont)

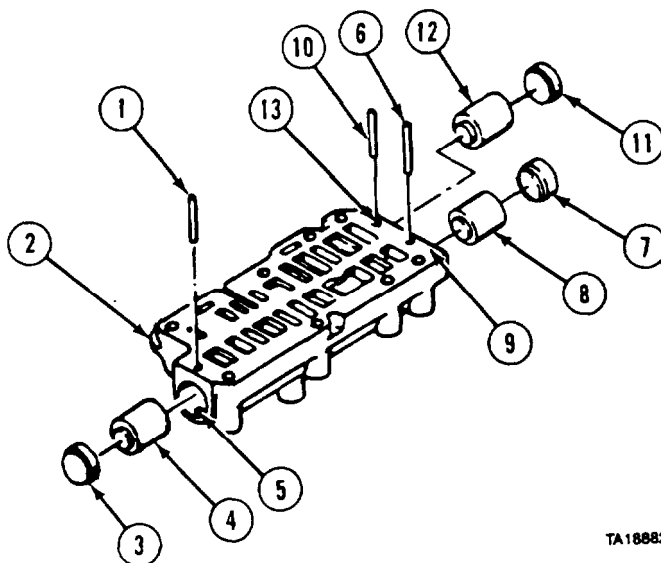
b. Disassembly.

TA188823

NOTE

When assembled, each valve should be installed in same bore from which valve was removed. Tag and mark all parts.

- (1) Remove retainer pin (1) from valve body (2).
- (2) Remove valve plug (3) and second and third clutch lockup cutoff valve (4) from bore (5).
- (3) Remove retainer pin (6) from valve body (2).
- (4) Remove valve plug (7) and first and second clutch lockup cutoff valve (8) from bore (9).
- (5) Remove retainer pin (10) from valve body (2).
- (6) Remove valve plug (11) and third and fourth clutch lockup cutoff valve (12) from bore (13).

c. Cleaning/Inspection.**WARNING**

Adhesives, solvents, and sealing compounds can burn easily, can give off harmful vapors, and are harmful to skin and clothing. To avoid injury or death, keep away from open fire and use in well-ventilated area. If adhesive, solvent, or sealing compound gets on skin or clothing, wash immediately with soap and water.

- (1) Clean valve body and valves with dry cleaning solvent.
- (2) Inspect valve body and valves for nicks, burrs, and scratches. Remove defects with crocus cloth. If scratches are deep or part is cracked, replace part.

d. Assembly.**NOTE**

Each valve should be installed in same bore from which valve was removed. When dry, check that all lockup cutoff valves move freely in their bores.

Apply lubricating oil to all parts.

- (1) Apply lubricating oil to valve body (2).
- (2) Install valve (12) and valve plug (11) in bore (13).
- (3) Install retainer pin (10) in valve body (2).
- (4) Install valve (8) and valve plug (7) in bore (9).
- (5) Install retainer pin (6) in valve body (2).
- (6) Install valve (4) and valve plug (3) in bore (5).
- (7) Install retainer pin (1) in valve body (2).

Transmission Maintenance Instructions (Cont)

7-22. LOCKUP CUTOFF VALVE BODY REMOVAL/REPAIR/INSTALLATION (CONT).

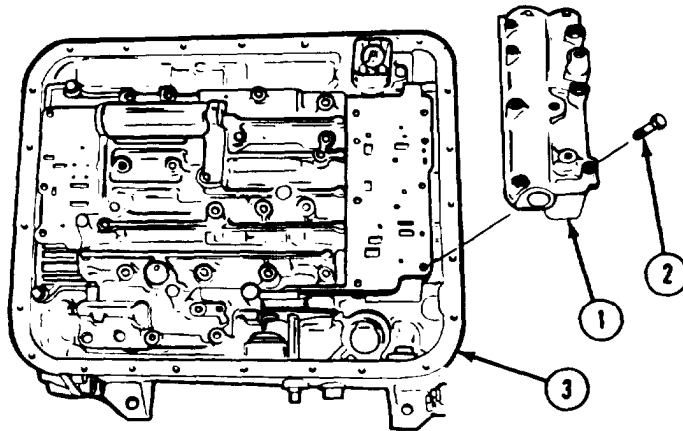

- e. **Installation.** Install valve (1) with eight screws (2) in transmission (3). Tighten screws to 8 to 12 lb-ft (11 to 16 N•m).
- f. **Follow-on Maintenance.** Install internal filter element. (para 7-12).

END OF TASK

7-23. GOVERNOR REMOVAL/INSTALLATION.	
This task covers:	
a. Removal	c. Follow-on Maintenance
b. Installation	
INITIAL SETUP	
<i>Models</i> All	<i>References</i> None
<i>Test Equipment</i> None	<i>Equipment Condition</i> TM or Para Condition Description TM 9-2320-279-20 Batteries disconnected.
<i>Special Tools</i> None	<i>Special Environmental Conditions</i> None
<i>Supplies</i> None	<i>General Safety Instructions</i> None
<i>Personnel Required</i> MOS 63W, Wheel vehicle repairer	<i>Level of Maintenance</i> Direct Support

Transmission Maintenance Instructions (Cont)

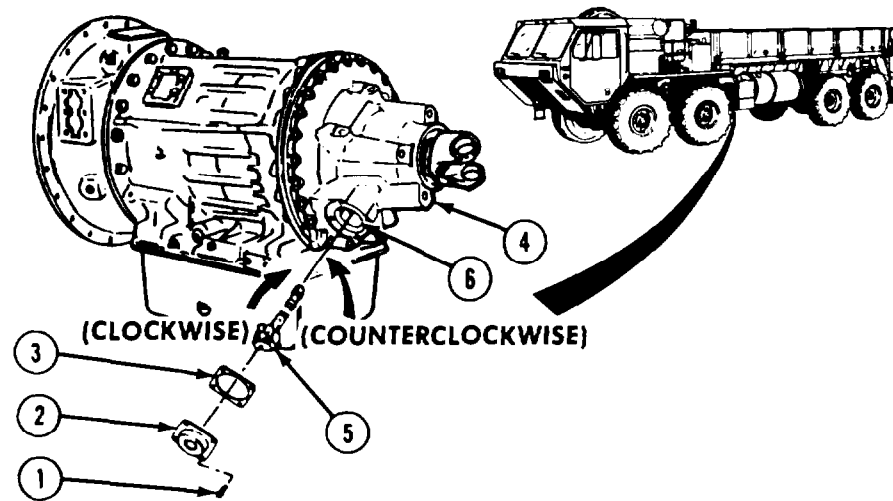
a. *Removal.*

- (1) Remove four screws (1), cover (2), and gasket (3) from transmission (4).
- (2) Turn governor (5) clockwise and remove from transmission (4).

b. *Installation.*

- (1) Turn governor (5) counterclockwise in port (6) to install.
- (2) Aline holes in gasket (3) and cover (2) with holes in port (6).
- (3) Install four screws (1), cover (2), and gasket (3) in transmission (4). Tighten screws to 10 to 13 lb-ft (14 to 18 N•m).

- c. *Follow-on Maintenance.* Connect batteries (TM 9-2320-279-20).

END OF TASK

CHAPTER 8 TRANSFER CASE MAINTENANCE

Contents	Para	Page
General	8-1	8-1
Transfer Case Removal/Installation	8-2	8-2
Transfer Case Mounting Brackets Removal/Installation	8-3	8-11
Transfer Case Repair	8-4	8-12
Oil Seal Removal/Installation	8-5	8-28
Top Input Shaft Repair	8-6	8-29
CenterShaftRepair	8-7	8-34
Lower Rear Output Shaft Repair	8-8	8-36
Lower Front Output Shaft Repair	8-9	8-38
Upper Shift Rod Assembly Repair	8-10	8-41
Lower Shift Rod Assembly Repair	8-11	8-42
HI-LO Range Transfer Case Lock-up Valve Repair	8-12	8-44
Traction Control Valve Repair	8-13	8-45
Lockout Shift Chamber Removal/Repair/Installation	8-14	8-47
Lubrication Pump Removal/Installation	8-15	8-52
Lubrication Pump Repair	8-16	8-54

Section I. INTRODUCTION

8-1. GENERAL. This chapter contains maintenance instructions for removal, installation, and repair of the transfer case and components at the direct support and general support maintenance level. Subassemblies and parts which must be removed before the transfer case can be removed are referenced to other paragraphs of this manual or in TM 9-2320-279-20. The HEMTT transfer is supplied as a dressed assembly including output yoke half. All HEMTTs except the M984E1 use the output yoke half supplied with the transfer. When replacing the transfer case on the M984E1 the output yoke on the new dressed transfer will have to be replaced with an M984E1 yoke end. Exchange the yoke end on the old transfer with that on the new, if the old yoke is still serviceable. If the old yoke end is not serviceable a new yoke end will have to be ordered.

Section II. TRANSFER CASE ASSEMBLY

Transfer Case Maintenance Instructions

8-2. TRANSFER CASE REMOVAL/INSTALLATION.

This task covers:

- a. Removal
- b. Installation
- c. Follow-on Maintenance

INITIAL SETUP

Models

All

Test Equipment

None

Special Tools

None

Supplies

Adhesive-sealant, silicone, Item 6, Appendix C
 Compound, sealing, Item 25, Appendix C
 Ties, cable, plastic, Item 65, Appendix C
 Oil, lubricating, Item 48, Appendix C
 Tags, identification, Item 60, Appendix C

Personnel Required

MOS 63W, Wheel vehicle repairer (2)

References

None

Equipment Condition

<i>TM or Para</i>	<i>Condition Description</i>
TM 9-2320-279-10	Transmission in neutral.
TM 9-2320-279-10	Transfer case in neutral.
LO 9-2320-279-12	Transfer case drained.
TM 9-2320-279-10	Air system drained.
TM 9-2320-279-20	Propeller shafts removed.
TM 9-2320-279-20	Speedometer sending unit removed.

Special Environmental Conditions

None

General Safety Instructions

None

Level of Maintenance

Direct Support

a. Disassembly.

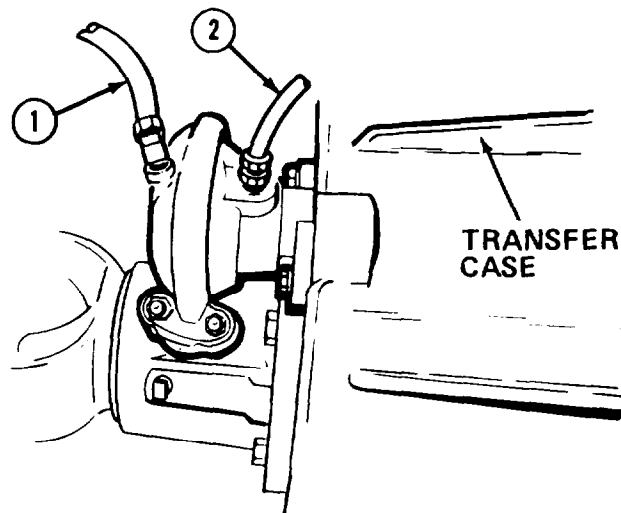
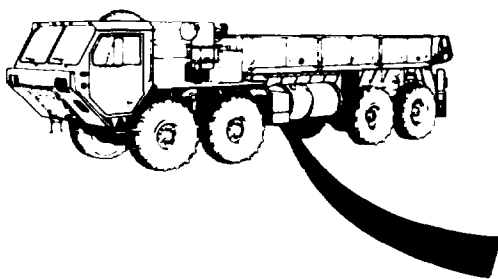

Transfer Case Maintenance Instructions (Cont)

WARNING

Axle is very heavy. Keep out from under heavy parts. Falling parts may cause serious injury or death.

- (1) Jack up rear axles and install jack stands to support rear axles.

NOTE

Tag and mark airhoses before disconnecting.

- (2) Disconnect two airhoses (1 and 2).

NOTE

Boot is black plastic cover located on top right side of transfer case.

- (3) Remove clamp (3) from boot (4).
- (4) Remove seven ratchet fasteners (5) and washers (6).
- (5) Remove boot (4) from shift cable (7).

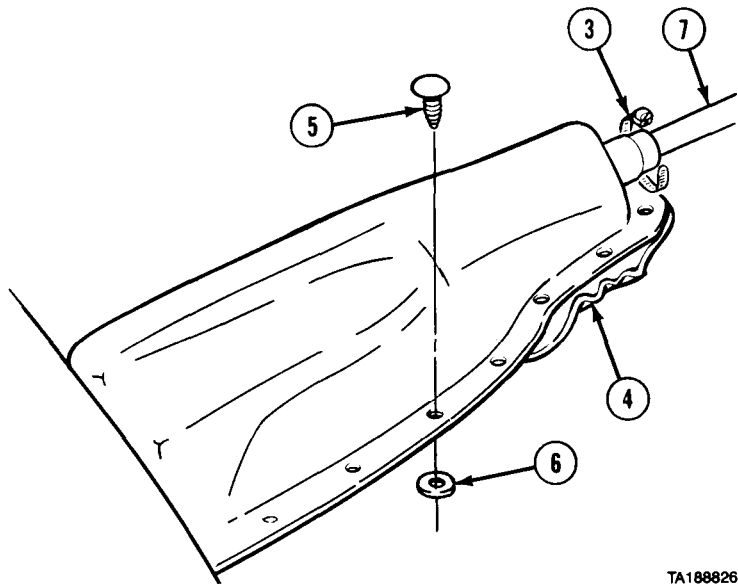

TA188826

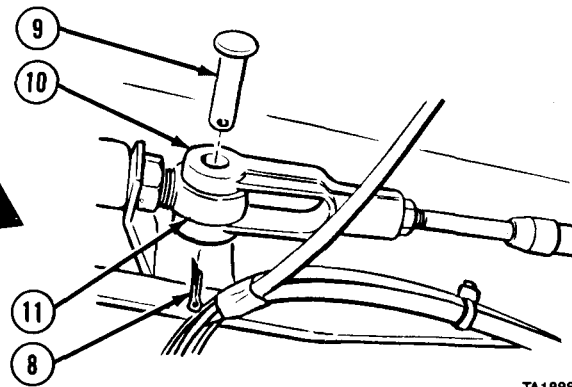
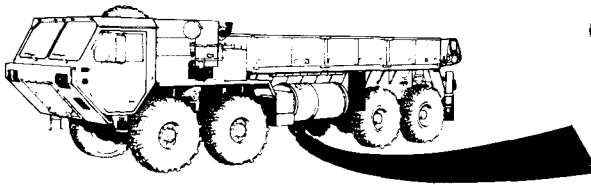

TA188827

- (6) Remove cotter pin (8) and pin (9).
- (7) Remove clevis (10) from shifter rod end (11).

Transfer Case Maintenance Instructions (Cont)

8-2. TRANSFER CASE REMOVAL/INSTALLATION (CONT).

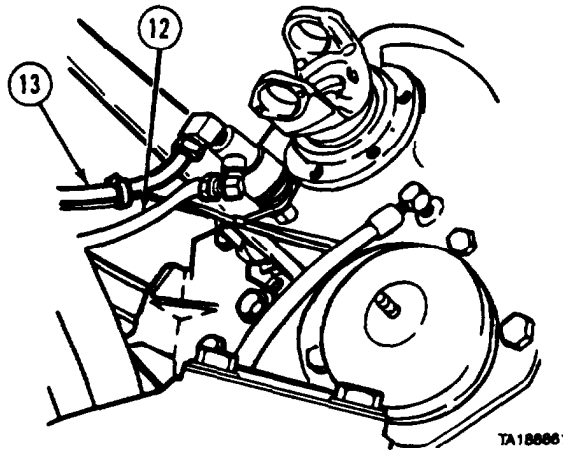

TA188861

NOTE

Cut plastic cable ties as needed.

- (8) Disconnect airhoses (12 and 13).

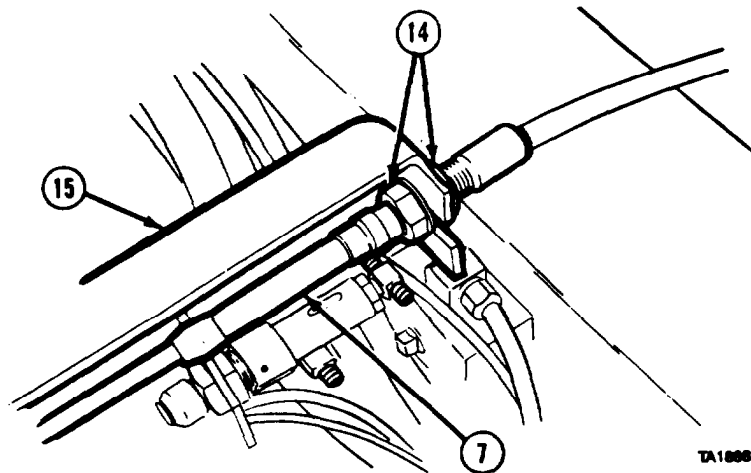

TA188828

- (9) Loosen two nuts (14) and slide shift cable (7) out of shift cable bracket (15).

Transfer Case Maintenance Instructions (Cont)

8-2. TRANSFER CASE REMOVAL/INSTALLATION (CONT).

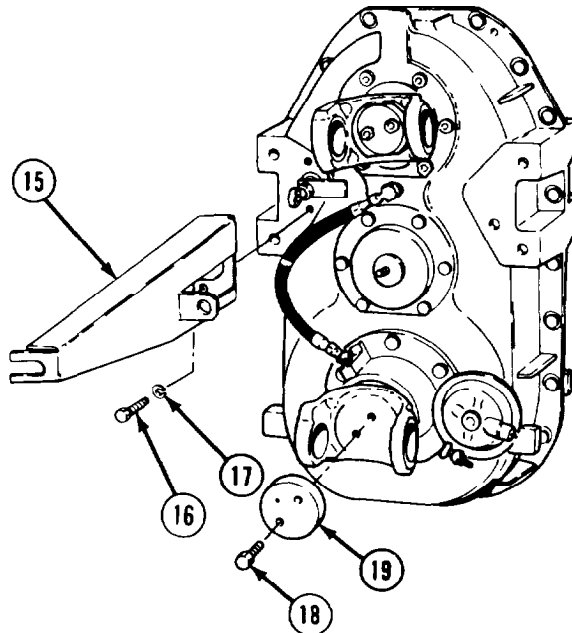

NOTE

Push valve will remain with shift cable bracket when bracket is removed.

- (10) Remove two screws (16), lockwashers (17), and shift cable bracket (15).
- (11) Remove two screws (18) and retainer washer (19).

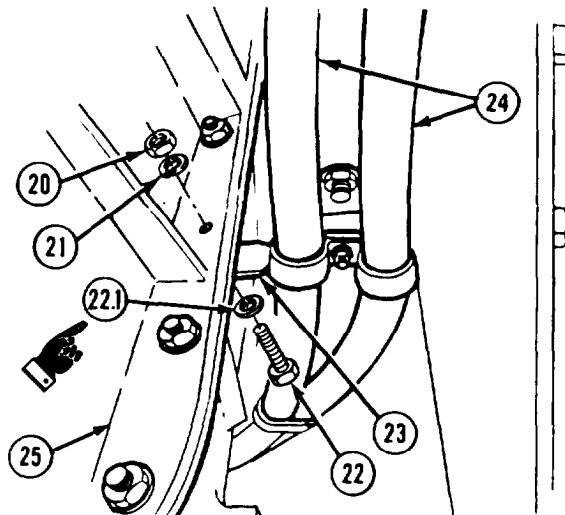

NOTE

Some models of vehicles have a washer under head of screw.

- (12) Remove nut (20), lockwasher (21), screw (22), washer (22.1), if installed, support bracket (23), and hydraulic hoses (24) from right side of transfer case (25).
- (13) Support transfer case (25) with suitable lifting device.

Transfer Case Maintenance Instructions (Cont)

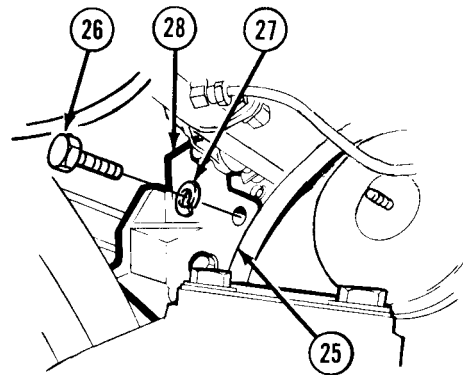
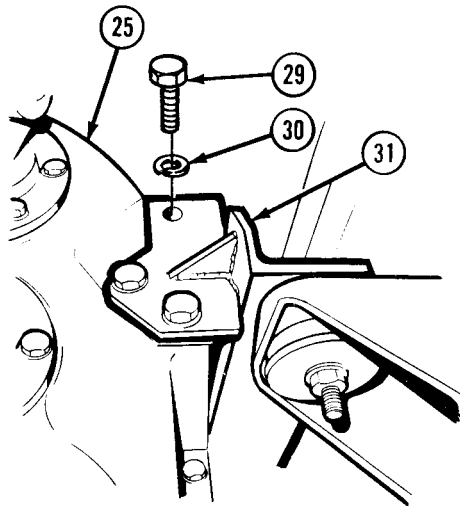

TA188832

- (14) Remove three screws (26) and lockwashers (27) from right mounting bracket (28) at front of transfer case (25).
- (15) Remove three screws (29) and lockwashers (30) from left mounting bracket (31) at front of transfer case (25).

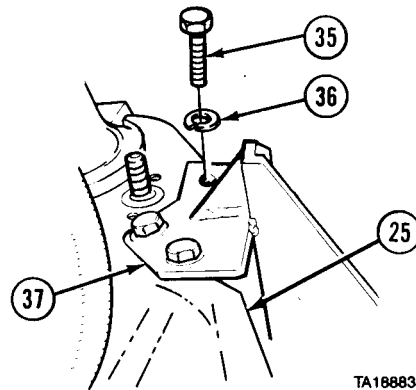
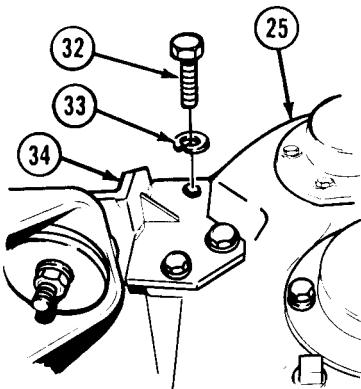

TA188833

- (16) Remove three screws (32) and lockwashers (33) from left mounting bracket (34) at rear of transfer case (25).
- (17) Remove three screws (35) and lockwashers (36) from right mounting bracket (37) at rear of transfer case (25).

WARNING

Transfer case is very heavy. Keep out from under heavy parts. Transfer case could fall causing serious injury or death.

- (18) Soldier A steadies transfer case (25) while Soldier B lowers lifting device and removes transfer case from under vehicle.

8-2. TRANSFER CASE REMOVAL/INSTALLATION (CONT).

b. Installation.

WARNING

Transfer case is very heavy. Keep out from under heavy parts. Transfer case could fall causing serious injury or death.

NOTE

On M984E1, when preparing transfer case for storage in reusable container, install 1710 series yoke. When preparing transfer case for installation on M984E1, install 1810 series yoke.

- (1) Soldier A steadies transfer case (1) on lifting device while Soldier B moves lifting device under vehicle.

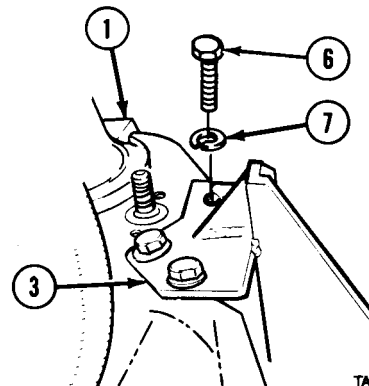
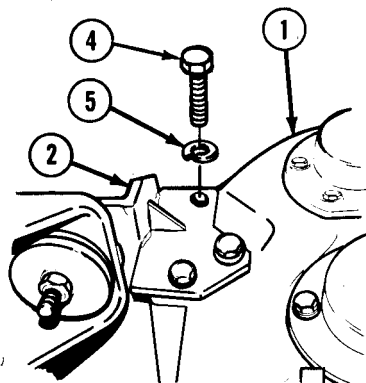
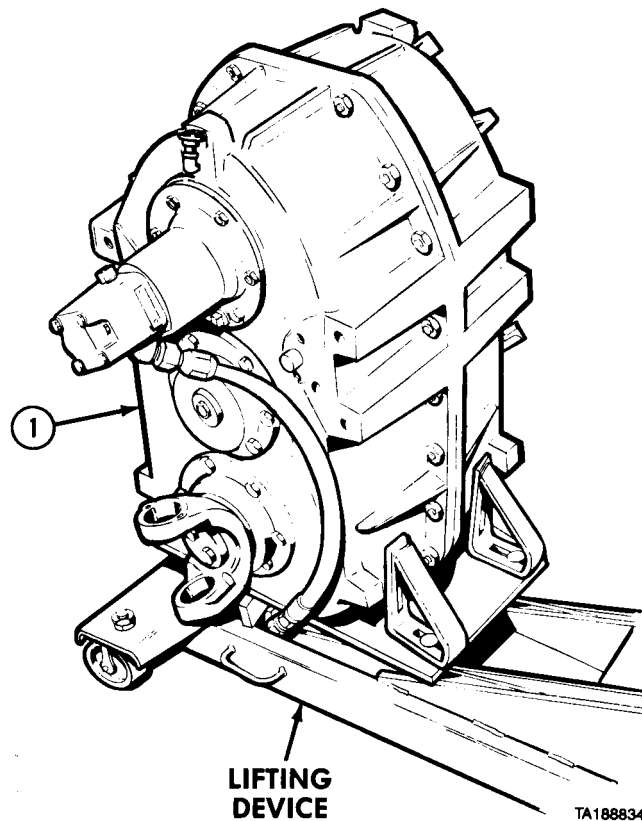

- (2) Soldier A guides transfer case (1) in left mounting bracket (2) and right mounting bracket (3) while Soldier B raises transfer case with lifting device.
- (3) Install three screws (4) and lockwashers (5) in left rear of mounting bracket (2). Do not tighten screws.
- (4) Install three screws (6) and lockwashers (7) in right rear of mounting bracket (3). Do not tighten screws.
- (5) Tighten screws (4 and 6) to 150 lb-ft (203 N·m).

Transfer Case Maintenance Instructions (Cont)

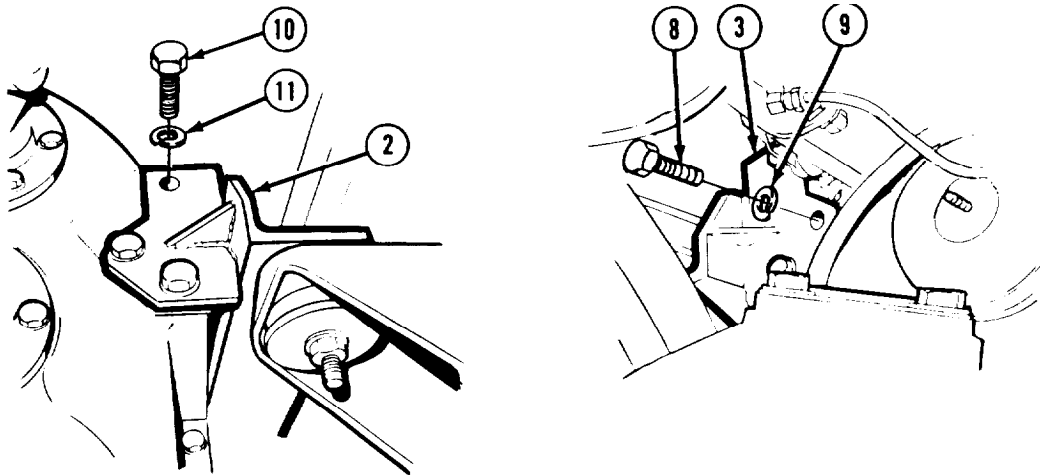

- (6) Install three screws (8) and lockwashers (9) in right front of mounting bracket (3).
- (7) Install three screws (10) and lockwashers (11) in left front of mounting bracket (2).
- (8) Lower lifting device and move lifting device aside.

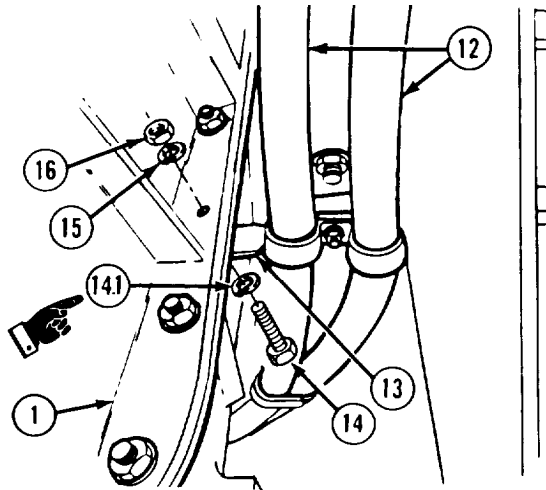

NOTE

Some models of vehicles have a washer under head of screw.

- (9) Install hydraulic hoses (12) and support bracket (13) on transfer case (1) with screw (14), washer (14.1), if removed, lockwasher (15), and nut (16).

Transfer Case Maintenance Instructions (Cont)

8-2. TRANSFER CASE REMOVAL/INSTALLATION (CONT).

- (10) Install shift cable bracket (17) with two screws (18) and lockwashers (19).

WARNING

Adhesives, solvents, and sealing compounds can burn easily, can give off harmful vapors, and are harmful to skin and clothing. To avoid injury or death, keep away from open fire and use in well-ventilated area. If adhesive, solvent, or sealing compound gets on skin or clothing, wash immediately with soap and water.

- (11) Apply silicone adhesive-sealant to end and splined surface of output shaft (20). Apply sealing compound to threads of two screws (21).

NOTE

Retaining screws may be either grade 5 or grade 8. Torque screws accordingly,

- (12) Install retainer washer (22) and two screws (21). Tighten grade 8 screws to 88 lb-ft (119 N•m). Tighten grade 5 screws to 60 lb-ft (81 N•m).

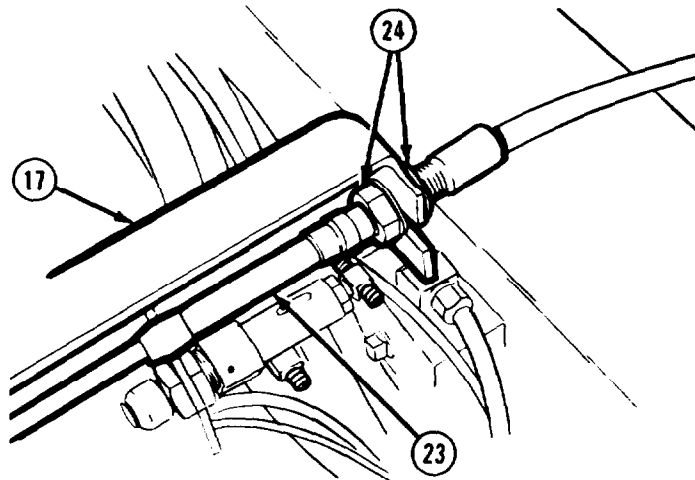
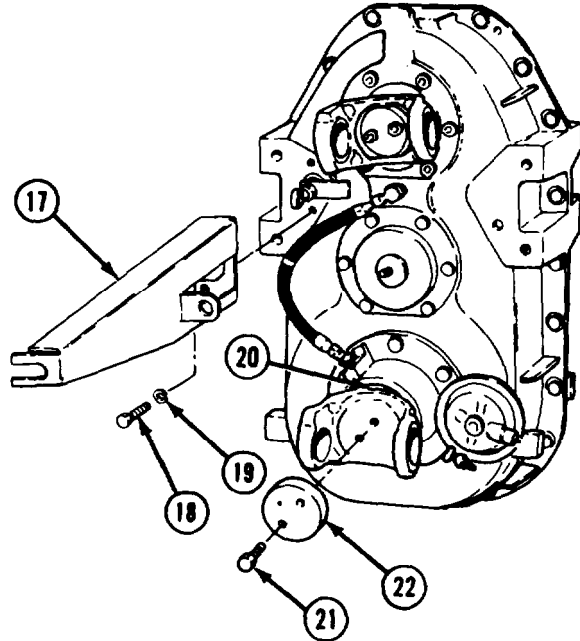

- (13) Slide shift cable (23) in slot in shift cable bracket (17). Tighten two nuts (24), one on each side of shift cable bracket slot.

Transfer Case Maintenance Instructions (Cont)

- (14) Connect airhoses (25 and 26).
- (15) Install speedometer sending unit (27)
(TM 9-2320-279-20).
- (16) Attach airhose (26) on base of sending unit (27)
with plastic cable tie.

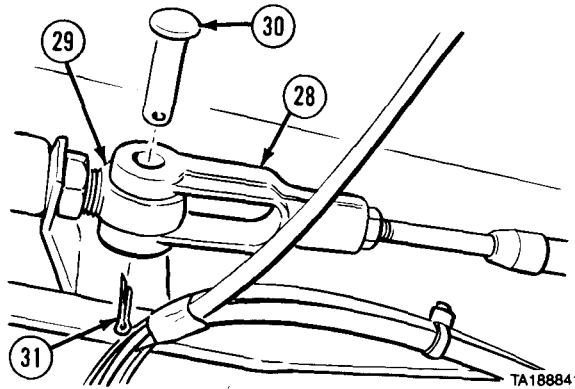
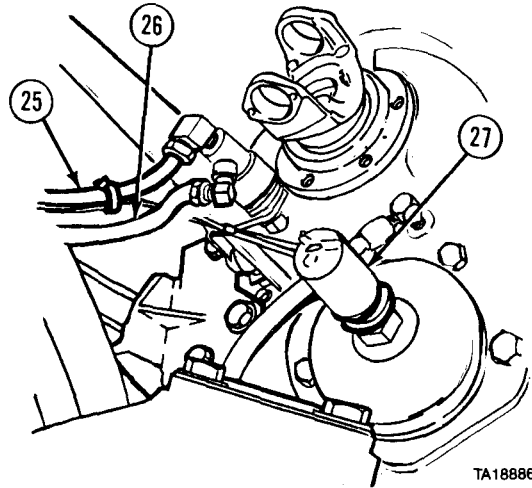

- (17) Slide clevis (28) on shifter rod end (29).
- (18) Install pin (30) and cotter pin (31).
- (19) Position boot (32) on shift cable (23).
- (20) Install seven ratchet fasteners (33) and washers (34).
- (21) Install clamp (35) on boot (32).

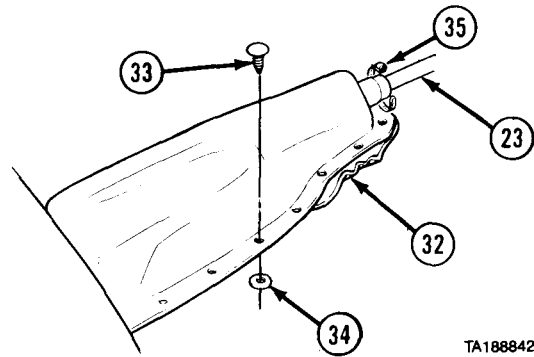

Transfer Case Maintenance Instructions (Cont)

8-2. TRANSFER CASE REMOVAL/INSTALLATION (CONT).

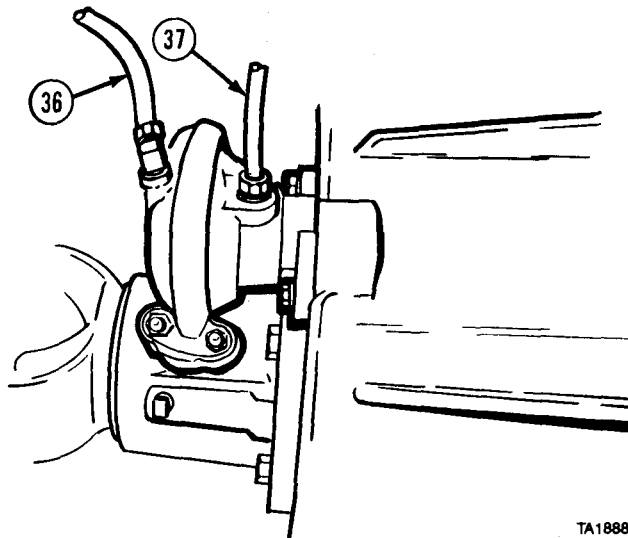

TA188843

(22) Connect two airhoses (36 and 37).

WARNING

Axle is very heavy. Keep out from under heavy parts. Falling parts may cause serious injury or death.

- (23) Jack up rear axles and remove jack stand.
- (24) Lower axles.

c. Follow-on Maintenance.

- (1) Install propeller shafts (TM 9-2320-279-20).
- (2) Fill transfer case with oil (LO 9-2320-279-12).
- (3) Start engine and build up air pressure (TM 9-2320-279-10).
- (4) Check operation of transfer case (TM 9-2320-279-10).
- (5) Shut off engine (TM 9-2320-279-10).

END OF TASK

Transfer Case Maintenance Instructions (Cont)

8-3. TRANSFER CASE MOUNTING BRACKETS REMOVAL/INSTALLATION.	
This task covers:	
a. Removal	c. Follow-on Maintenance
b. Installation	
INITIAL SETUP	
<i>Models</i>	<i>Equipment Condition</i>
All	<i>TM or Para</i> <i>Condition Description</i>
<i>Test Equipment</i>	TM 9-2320-279-20 Fuel tank removed.
None	Para 13-8 Transfer case support assembly removed.
<i>Special Tools</i>	<i>Special Environmental Conditions</i>
None	None
<i>Supplies</i>	<i>General Safety Instructions</i>
None	None
<i>Personnel Required</i>	<i>Level of Maintenance</i>
MOS 63W, Wheel vehicle repairer	Direct Support
<i>References</i>	
None	

a. Removal.

NOTE

Left and right brackets are removed and installed the same way. Right bracket does not have hose clamp.

- (1) Remove six screws (1) and washers (2) from transfer case (3)
- (2) Remove screw (4), nut (5), washer (6) and clamp (7).
- (3) Remove bracket (8).

b. Installation.

- (1) Install bracket (8) on transfer case (3) with six screws (1) and washers (2).
- (2) Install clamp (7), screw (4), washer (6), and nut (5).

c. Follow-on Maintenance.

- (1) Install transfer case support assembly (para 13-8).
- (2) Install fuel tank (TM 9-2320-279-20).

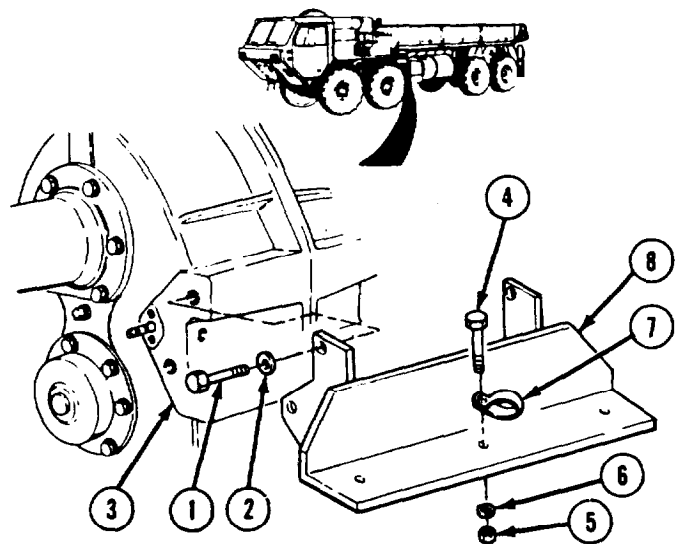

TA189089

END OF TASK

Transfer Case Maintenance Instructions (Cont)

8-4. TRANSFER CASE REPAIR.

This task covers:

- a. Disassembly
- b. Cleaning/Inspection
- c. Assembly
- d. Follow-on Maintenance

INITIAL SETUP

Models
All

References
None

Test Equipment
Dial indicator

Equipment Condition
TM or Para *Condition Description*
Transfer case mounted in transfer case stand.

Special Tools
None

TM 9-2320-279-20 Breather removed.
Para 8-5 Oil seals removed.
Para 8-14 Lockout shift chamber removed.
Para 8-15 Lubrication pump removed.

Supplies
Solvent, drycleaning, Item 57, Appendix C
Oil, lubricating, Item 46, Appendix C
Oil, lubricating, Item 48, Appendix C
Adhesive-sealant, silicone, Item 6, Appendix C
Adhesive, Item 8, Appendix C
Grease, automotive and artillery, Item 34, Appendix C
Compound, sealing, Item 26, Appendix C
Compound, sealing, pipe thread, Item 28.1, Appendix C
Tags, identification, Item 60, Appendix C

Special Environmental Conditions
None

General Safety Instructions
None

Level of Maintenance
General Support

Personnel Required
MOS 63W, Wheel vehicle repairer (2)

a. Disassembly.

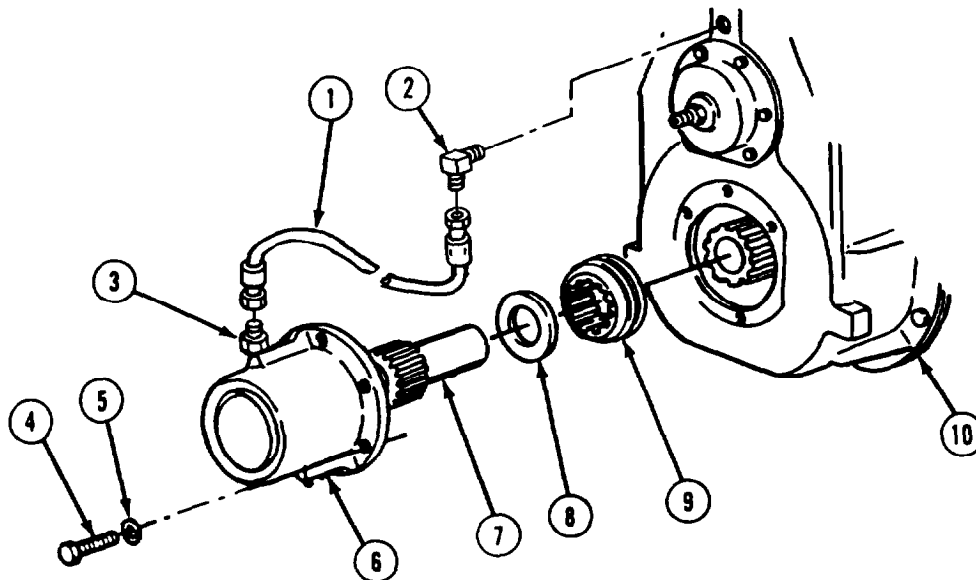

Transfer Case Maintenance Instructions (Cont)

- (1) Remove hose (1).
- (2) Remove two elbows (2 and 3).

NOTE

Note location of groove in clutch collar before removing.

- (3) Remove six screws (4), lockwashers (5), lower front bearing cap (6), lower front output shaft assembly (7), input shaft yoke spacer (8), and clutch collar (9) from transfer case (10).

- (4) Remove sleeve (11).
- (5) Remove six screws (12), lockwashers (13), end cap (14), speedometer drive shaft (15), thrust bearing (16), thrust washer (17), and spring (18).

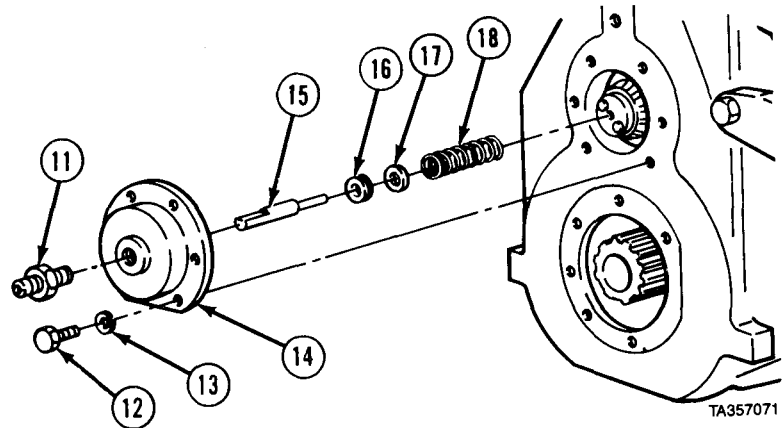

- (6) Remove two screws (19), lockwashers (20), and cover (21).
- (7) Remove plug (22), outer spring (23), and outer ball (24) from transfer case rear half (25).

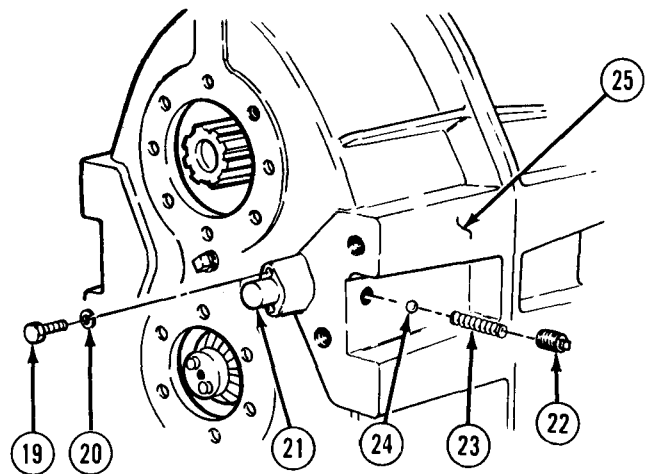

Transfer Case Maintenance Instructions (Cont)

8-4. TRANSFER CASE REPAIR (CONT).

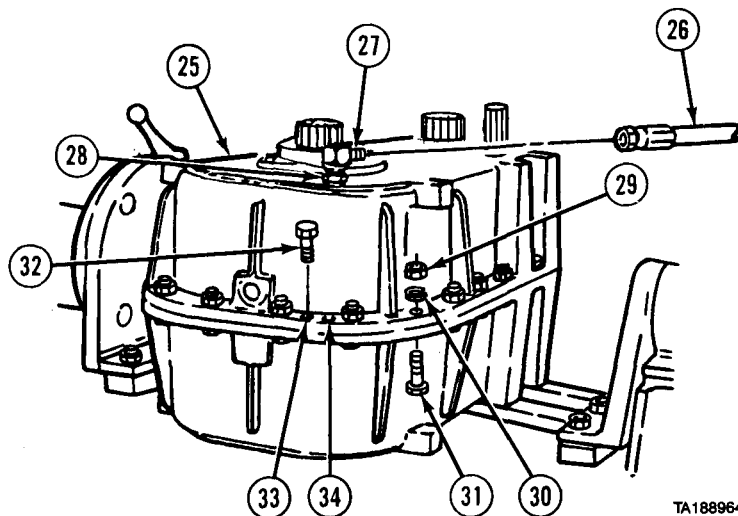

TA188964

NOTE

Input shaft yoke spacer may fall out when case is turned rear side up.

- (8) Remove hose (26) and elbow (27).
- (9) Remove adapter and strainer (28).
- (10) Remove 19 nuts (29), lockwashers (30), and screws (31).
- (11) Install two screws (32) in transfer case rear half jackscrew holes (33) next to dowels (34).
- (12) Tighten screws (32) alternately to force transfer case rear half (25) off dowels (34). Remove screws.

CAUTION

Lift rear case half straight up to prevent possible damage to shift rod.

NOTE

Inner detent ball on shift rod will fall in front case half during separation.

- (13) Using suitable lifting device and sling, lift transfer case rear half (25) off front case half (10).

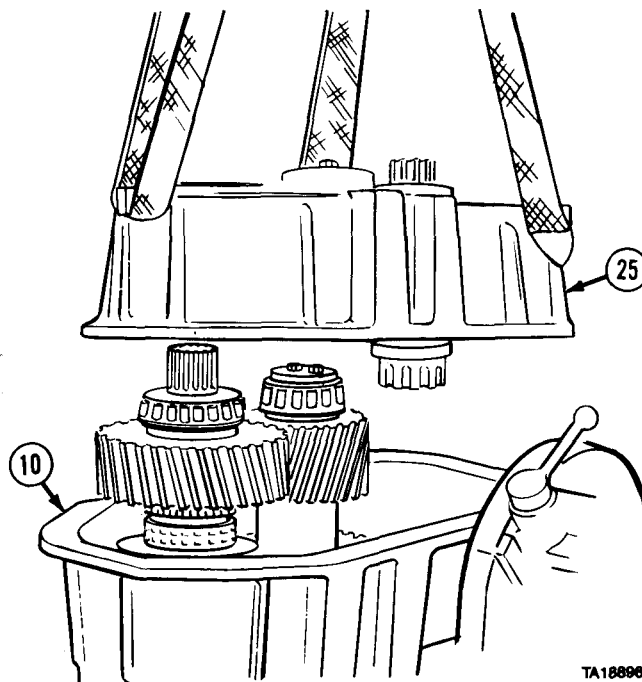

TA188966

Transfer Case Maintenance Instructions (Cont)

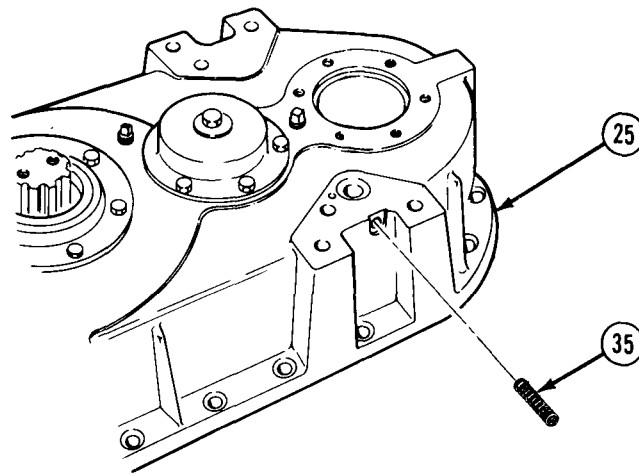

TA188967

(14) Remove inner spring (35) from transfer case rear half (25).

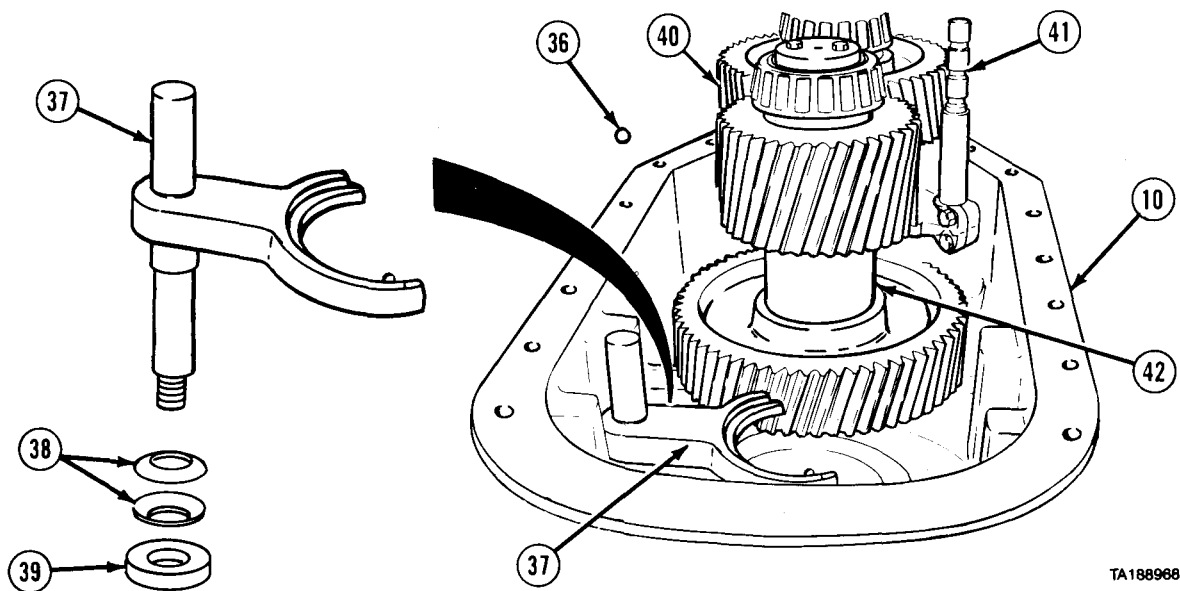

TA188968

NOTE

Check that eight spring disks and one spacer are removed with lower shift rod.

- (15) Take inner detent ball (36) out of transfer case front half (10).
- (16) Remove lower shift rod assembly (37) with eight spring disks (38) and one spacer (39) attached.
- (17) Lift top front input shaft assembly (40) and upper shift rod assembly (41) from transfer case front half (10).
- (18) Lift center shaft assembly (42) from transfer case front half (10).

Transfer Case Maintenance Instructions (Cont)

8-4. TRANSFER CASE REPAIR (CONT).

- (19) Remove six screws (43) and lockwashers (44) from transfer case rear half (25).
- (20) Using softhead hammer, drive bearing support (45) off dowels (46) and remove.
- (21) Lift lower rear output shaft assembly (47) from transfer case rear half (25).

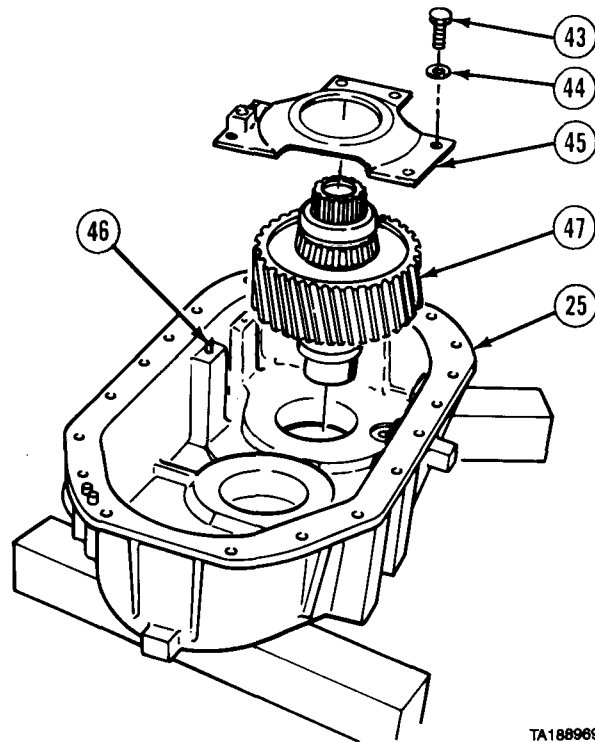

TA188969

- (22) Straighten tangs (48) of lockwasher (49) and remove locknut (50) and lockwasher.
- (23) Remove spacers (51 and 52).
- (24) Remove bearing cup (53) from bearing support (45).

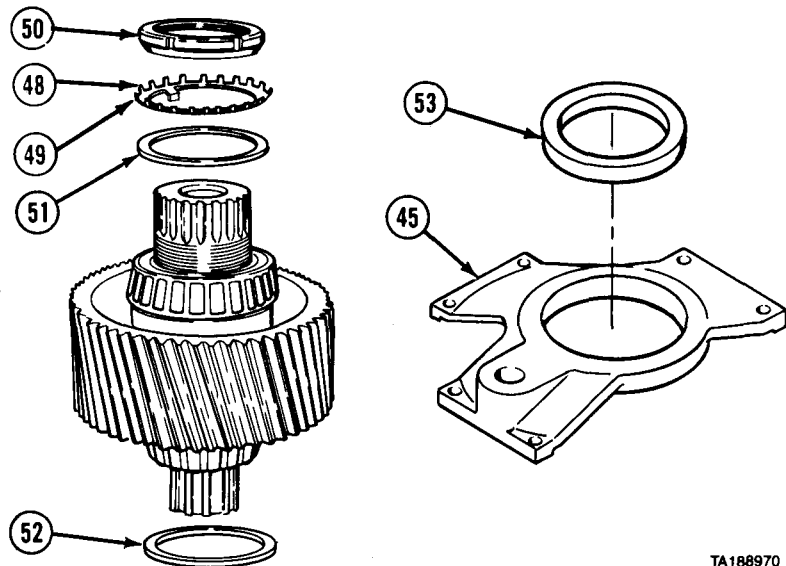

TA188970

Transfer Case Maintenance Instructions (Cont)

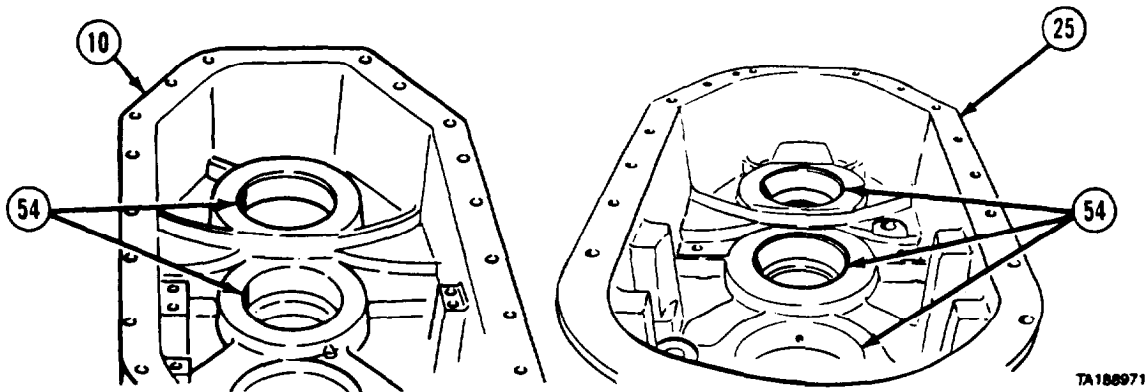

(25) Remove three bearing cups (54) from transfer case rear half (25) and two bearing cups from transfer case front half (10).

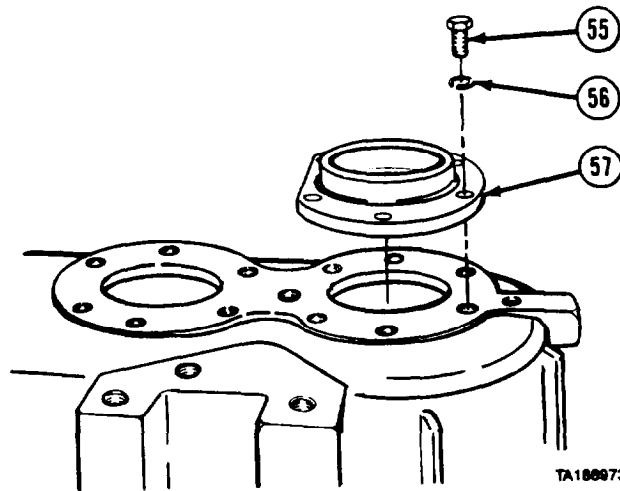

(26) Remove six screws (55), lockwashers (56), and upper end cap (57).

b. Cleaning/Inspection.

WARNING

Adhesives, solvents, and sealing compounds can burn easily, *can* give off harmful vapors, and are harmful to skin and clothing. To avoid injury or death, keep away from open fire and use in well-ventilated area. If adhesive, solvent, or sealing compound gets on skin or clothing, wash immediately with soap and water.

- (1) Clean all metal parts with dry cleaning solvent.
- (2) Clean all sealing surfaces.
- (3) Inspect all machined surfaces for damage.
- (4) Inspect both case halves for cracks or damage.
- (5) Inspect all threads for peeled or crossed condition.
- (6) Replace all oil seals and damaged parts.

Transfer Case Maintenance Instructions (Cont)

8-4. TRANSFER CASE REPAIR (CONT).

a. *Assembly.*

WARNING

Adhesives, solvents, and sealing compounds can burn easily, can give off harmful vapors, and are harmful to skin and clothing. To avoid injury or death, keep away from open fire and use in well-ventilated area. If adhesive, solvent, or sealing compound gets on skin or clothing, wash immediately with soap and water.

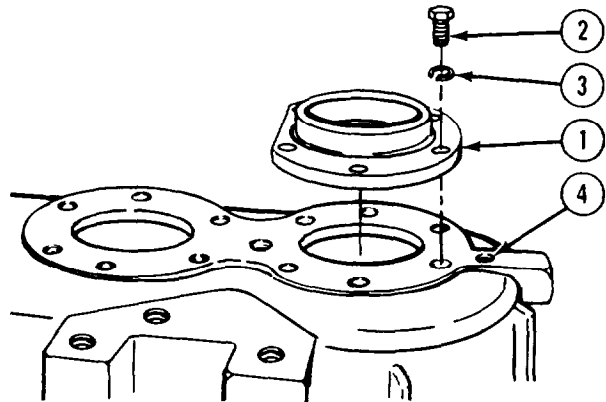

- (1) Apply light bead of adhesive to inside flange of end cap (1). Apply sealing compound to threads of six screws (2). Install six screws (2), lockwashers (3), and end cap in transfer case front half (4).

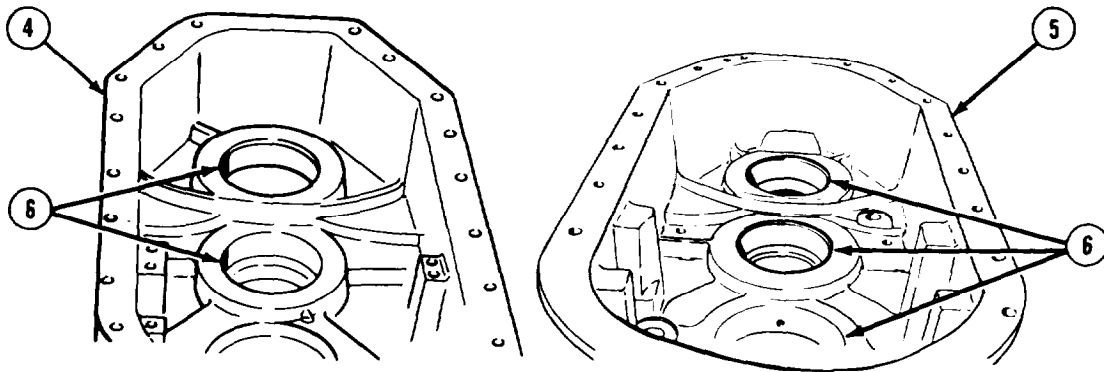

- (2) Support transfer case front and rear halves (4 and 5), open side up, on clean work surface.

NOTE

Use hammer and brass drift to seat taper bearing cups against shoulders.

- (3) Install three bearing cups (6) in transfer case rear half (5) and two bearing cups in transfer case front half (4).
- (4) Install bearing cup (7) in bearing support (8).

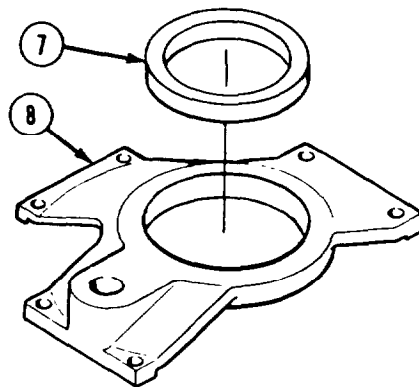

Transfer Case Maintenance Instructions (Cont)

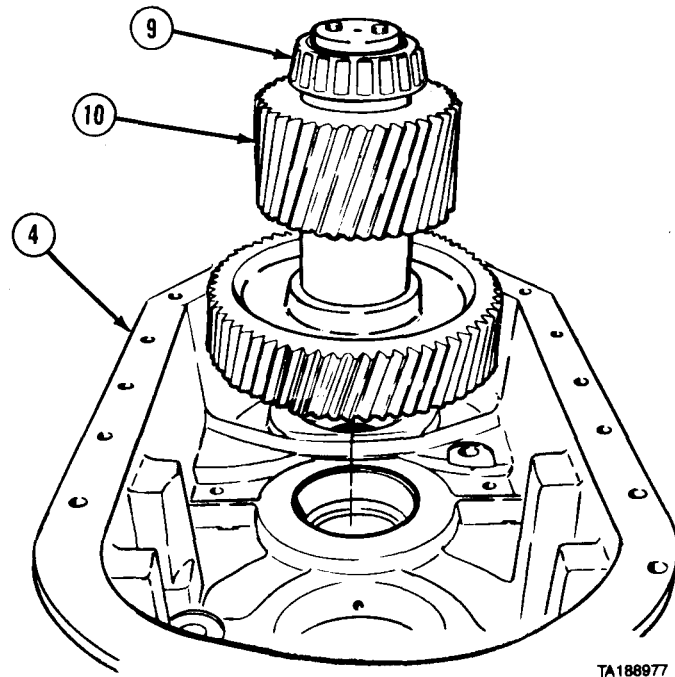

- (5) Mount transfer case front half (4) on suitable workstand.
- (6) Coat bearing cones (9) with lubricating oil (item 48).
- (7) Using suitable sling and lifting device, install center shaft assembly (10) in transfer case front half (4).

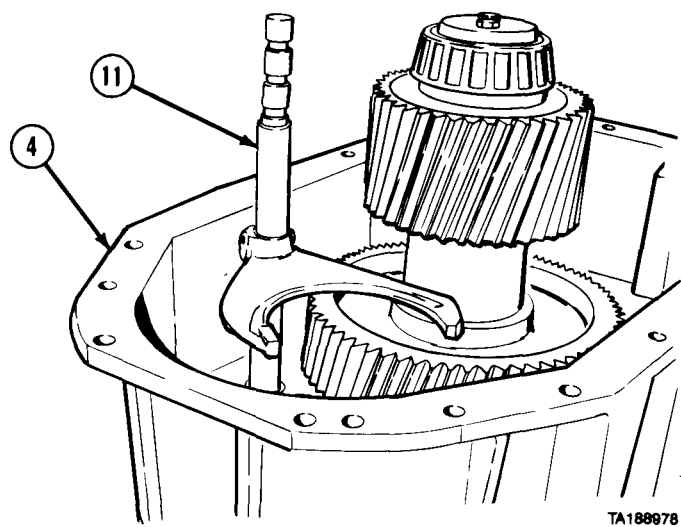

- (8) Install upper shift rod assembly (11) in transfer case front half (4) with grooved end up.

Transfer Case Maintenance Instructions (Cont)

8-4. TRANSFER CASE REPAIR (CONT).

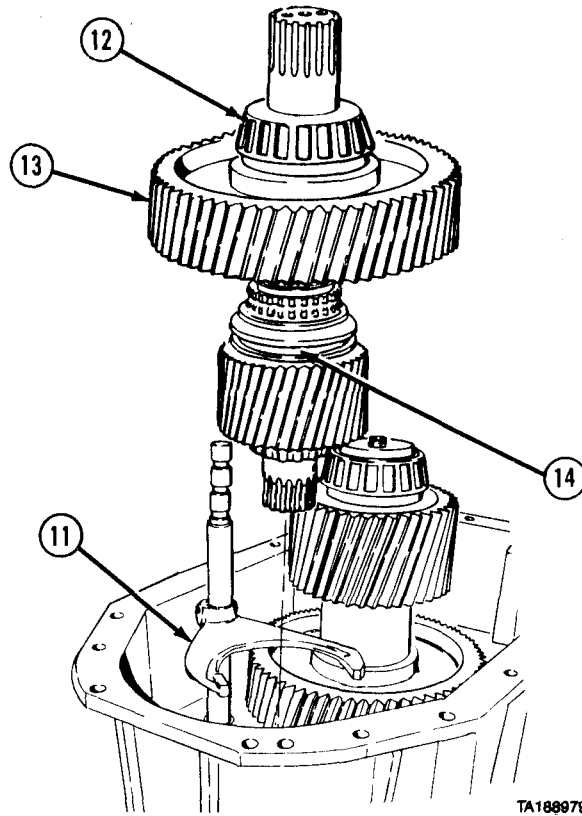

(9) Coat bearing cone (12) with lubricating oil (item 48).

CAUTION

Keep top front input shaft assembly and shaft rod assembly parallel to center shaft assembly so gears mesh properly and to prevent binding and possible damage to shift rod assembly.

(10) Using suitable sling and lifting device, install top front input shaft assembly (13) and engage upper shift rod assembly (11) in clutch collar (14).

Transfer Case Maintenance Instructions (Cont)

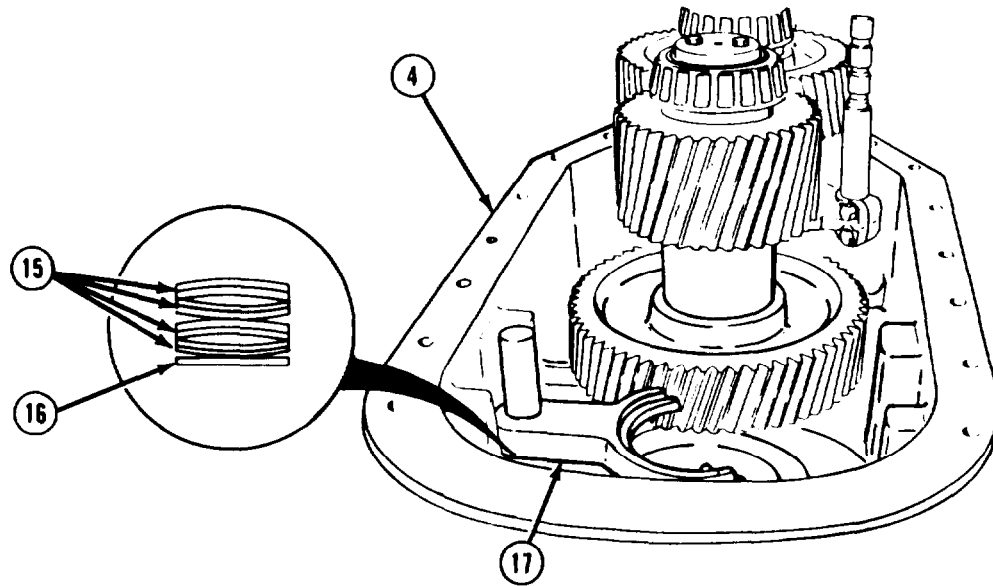

- (11) Check the eight spring disks (15) and spacer (16) are assembled on lower shift rod assembly (17) as shown.
- (12) Install lower shift rod assembly (17) in front case half (4) with spring disk end down and spacer (16) against front case half.
- (13) Install spacers (18 and 19) on lower rear output shaft assembly (20).
- (14) Install lockwasher (21) and locknut (22). Tighten locknut to 180 to 220 lb-ft (244 to 298 N•m).
- (15) Using hammer and punch, bend up tangs (23) of lockwasher (21).

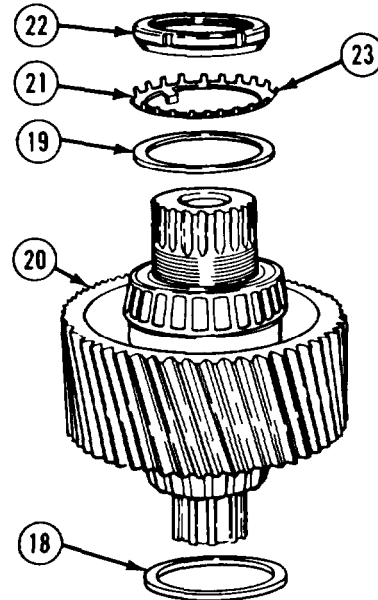

Transfer Case Maintenance Instructions (Cont)

8-4. TRANSFER CASE REPAIR (CONT).

- (16) Coat bearing cone (24) with lubricating oil (Item 48).
- (17) Using suitable sling and lifting device, install lower rear output shaft assembly (20) in transfer case rear half (5).
- (18) Install bearing support (8) with softhead hammer to seat on dowels (25).

WARNING

Adhesives, solvents, and sealing compounds can burn easily, can give off harmful vapors, and are harmful to skin and clothing. To avoid injury or death, keep away from open fire and use in well-ventilated area. If adhesive, solvent, or sealing compound gets on skin or clothing, wash immediately with soap and water.

- (19) Coat threads of six screws (26) with sealing compound and install screws and lockwashers (27). Tighten screws to 40 lb-ft (54 N•m).
- (20) Turn transfer case rear half (5) over.
- (21) Remove six screws (28), lockwashers (29), shims (31), and end cap (30). Clean off old sealant.
- (22) Add any combination of three available shims (31) to equal 0.060 in. (1.5 mm).
- (22.1) Apply sealing compound between shims (31) and install shims.

NOTE

After checking end play (steps (23) through (26)), remove screws, lockwashers, and end cap. Apply sealing compound to threads of six screws. Repeat step (23), then go to step (27).

- (23) Install end cap (30) with six lockwashers (29) and screws (28). Tighten screws to 60 lb-ft (81 N•m).

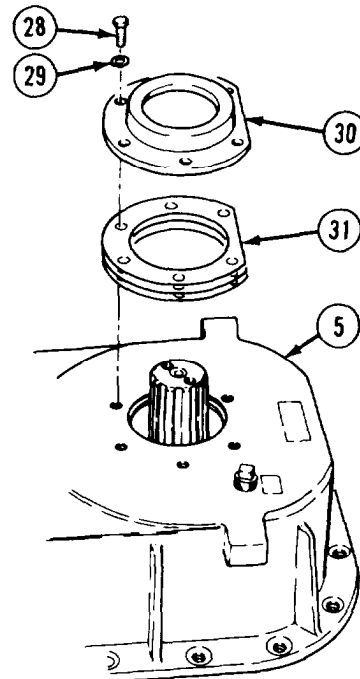
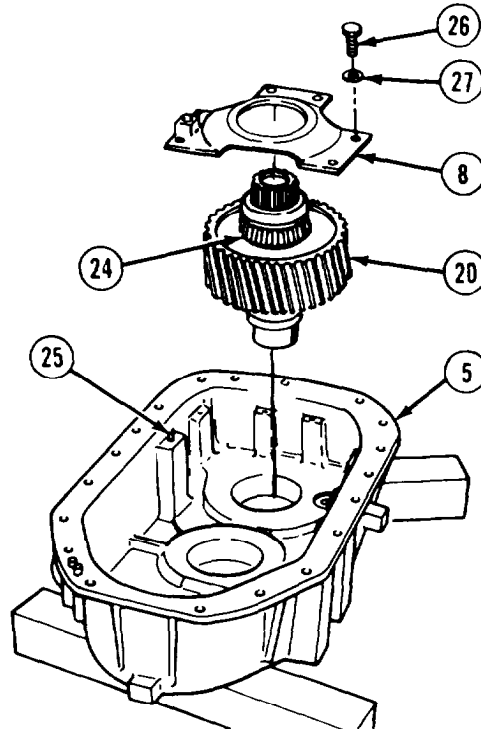

Transfer Case Maintenance Instructions (Cont)

NOTE

Rotate lower rear output shaft assembly back and forth to seat rollers before checking end play.

- (24) Mount dial indicator (32) on machined surface of bearing support (8).
- (25) Using pry bar and fulcrum, check end play of lower rear output shaft assembly (20). End play tolerance is 0.003 to 0.006 in. (0.08 to 0.15 mm).
- (26) Add or remove shims to achieve proper end play. Refer to steps (21) through (25).

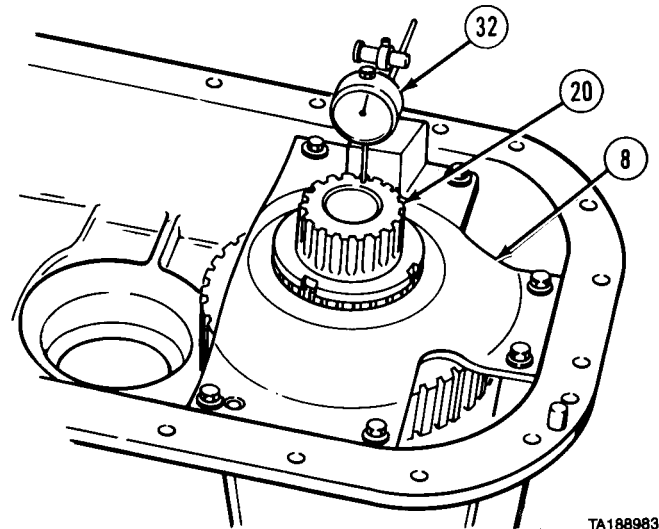

TA188983

WARNING

Adhesives, solvents, and sealing compounds can burn easily, can give off harmful vapors, and are harmful to skin and clothing. To avoid injury or death, keep away from open fire and use in well-ventilated area. If adhesive, solvent, or sealing compound gets on skin or clothing, wash immediately with soap and water.

- (27) Apply adhesive to flange of transfer case front half (4).
- (28) Using sling and suitable hoist, position transfer case rear half (5) over transfer case front half (4).

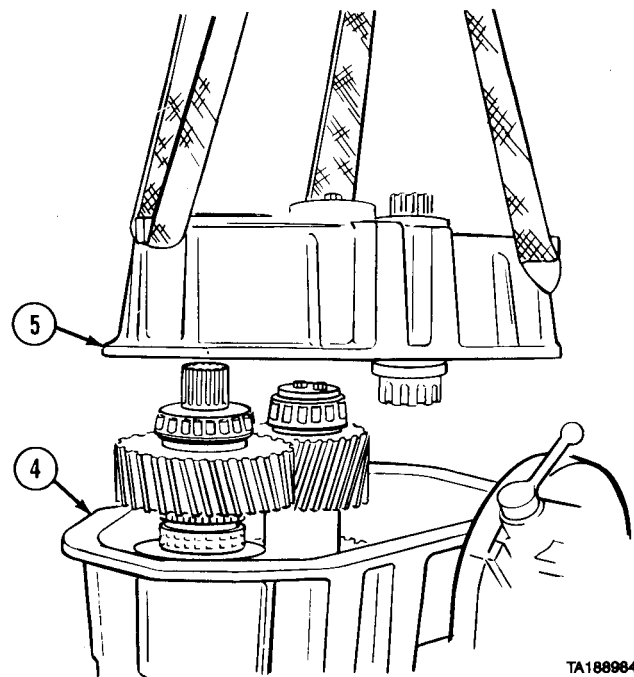

TA188984

Transfer Case Maintenance Instructions (Cont)

8-4. TRANSFER CASE REPAIR (CONT).

- (29) Lower transfer case rear half (5) on upper shift rod assembly (11) until end of upper shift rod assembly is just below detent passage (33).
- (30) Insert inner spring (34) and inner detent ball (35).

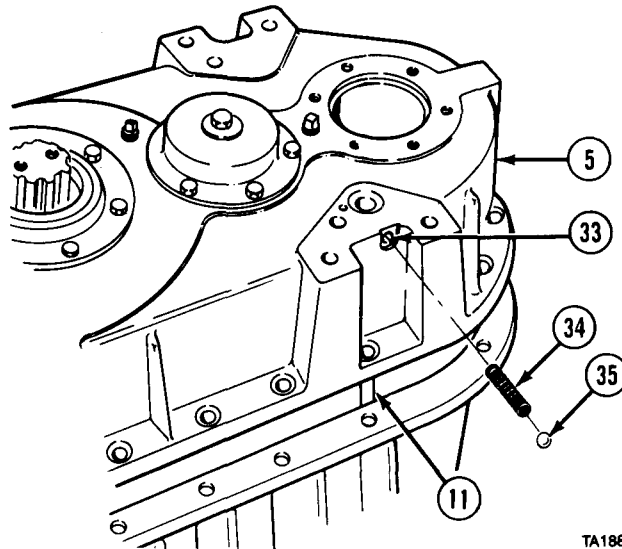

TA188965

- (31) Align transfer case rear half (5) with dowel pins (36) in transfer case front half (4).
- (32) Soldier A guides transfer case rear half (5) on dowel pins (36) while Soldier B lowers transfer case rear half.
- (33) Tap transfer case rear half (5) to seat against flange of transfer case front half (4).

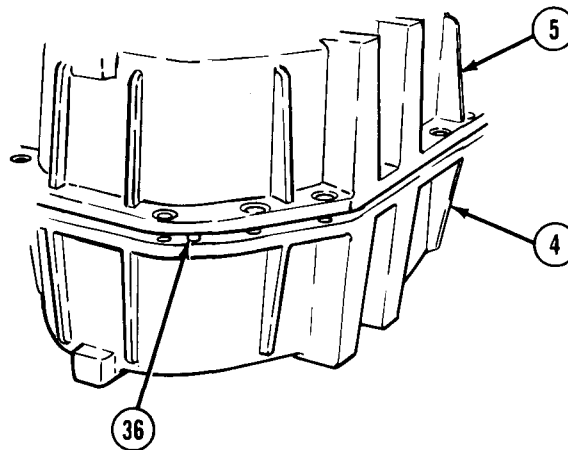

TA188966

- (34) Coat 19 screws (37) with lubricating oil (item 46) and install screws, lockwashers (38), and nuts (39). Tighten nuts to 60 lb-ft (81 N·m).

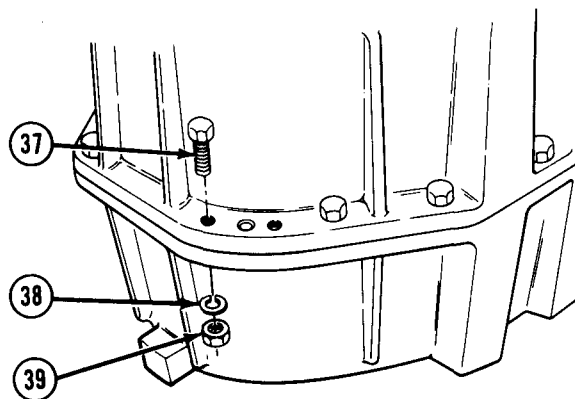

TA188967

Transfer Case Maintenance Instructions (Cont)

- (34.1) Apply pipe thread sealing compound to threads of plug (42).
- (35) Install outer ball (40), outer spring (41), and plug (42).

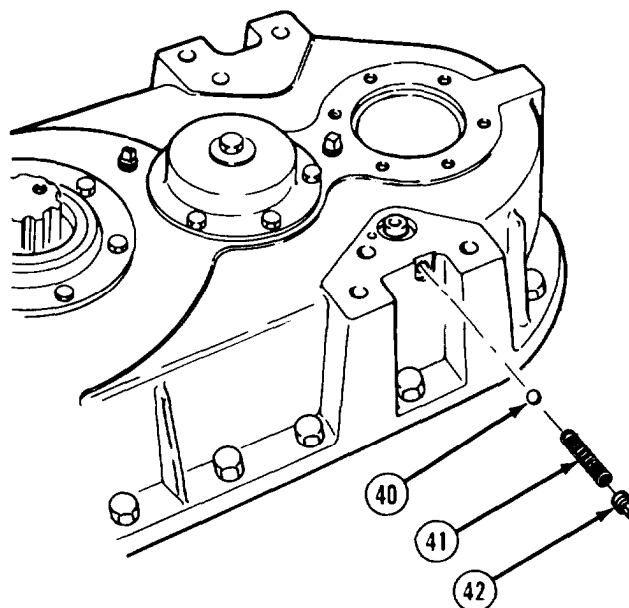

- (36) Remove six screws (43), lockwashers (44), shims (46), and end cap (45). Clean off old sealant.
- (37) Add any combination of shims (46) to equal 0.060 in. (1.5 mm).
- (37.1) Apply sealing compound between shims (46) and install shims.

NOTE

After checking end play (steps (38) through (43)), remove screws, lockwashers, and end cap. Apply sealing compound to threads of six screws. Repeat step (38), then go to step (44).

- (38) Install end cap (45) with six lockwashers (44) and screws (43). Tighten screws to 60 lb-ft (81 N•m).
- (39) Remove plug (47) from end cap (45). Clean off old sealant.
- (40) Thread a 3/8 in. x 4 in. (9.5 mm x 102 mm) long coarse-thread screw (48) through hole in end cap (45).
- (41) Mount dial indicator on machined surface with indicator shaft resting on screw (48).
- (42) Pry or lift up on screw (48) to check end play.
- (43) Add or remove any combination of three available shims (46) as needed to provide 0.003 to 0.006 in. (0.08 to 0.15 mm) end play. Refer to steps (36) through (42) to add or remove shims.
- (44) Remove screw (48).
- (45) Apply sealing compound to plug (47) and install.

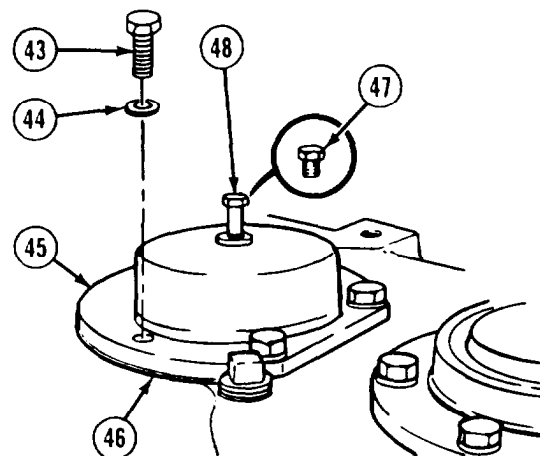

Transfer Case Maintenance Instructions (Cont)

8-4. TRANSFER CASE REPAIR (CONT).

WARNING

Adhesives, solvents, and sealing compounds can burn easily, can give off harmful vapors, and are harmful to skin and clothing. To avoid injury or death, keep away from open fire and use in well-ventilated area. If adhesive, solvent, or sealing compound gets on skin or clothing, wash immediately with soap and water.

- (45.1) Apply adhesive to mounting surface of cover (49).
- (46) Install cover (49) with two screws (50) and lockwashers (51). Tighten screws to 14 lb-ft (19 N•m).
- (47) Coat threads of adapter and strainer (52) with pipe thread sealing compound and install adapter and strainer.
- (48) Coat threads of elbow (53) with pipe thread sealing compound and install elbow and hose (54).
- (49) Turn workstand to place transfer case front half (4) up.

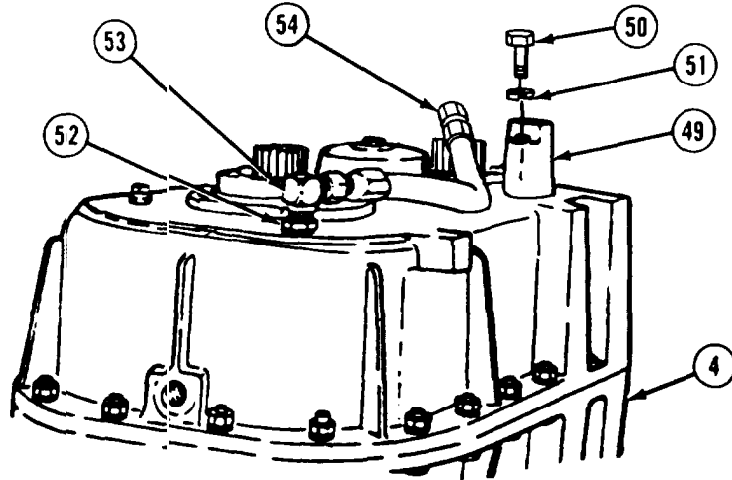

NOTE

Remove oil pump mounting from rear case half for access to shims.

- (50) To set end play of top front input shaft (13) repeat steps (40) through (43).

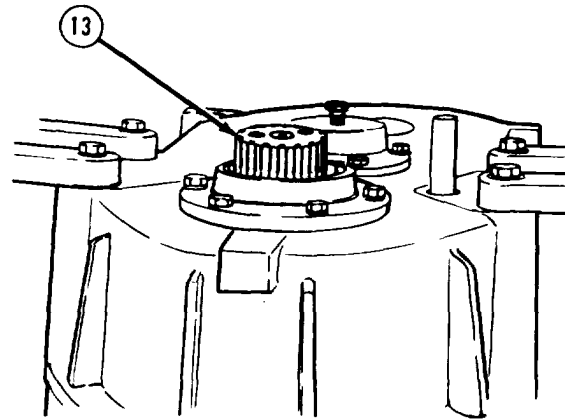

- (51) Install speedometer drive shaft (55), spring (56), thrust washer (57), and thrust bearing (58) in center shaft assembly (10).

- (52) Apply light bead of adhesive around inside flange of end cap (59) and sealing compound to threads of six screws (60). Install six screws (60), lockwashers (61), and end cap.

- (53) Apply pipe thread sealing compound to underside of nut on sleeve (62) and install in end cap (59).

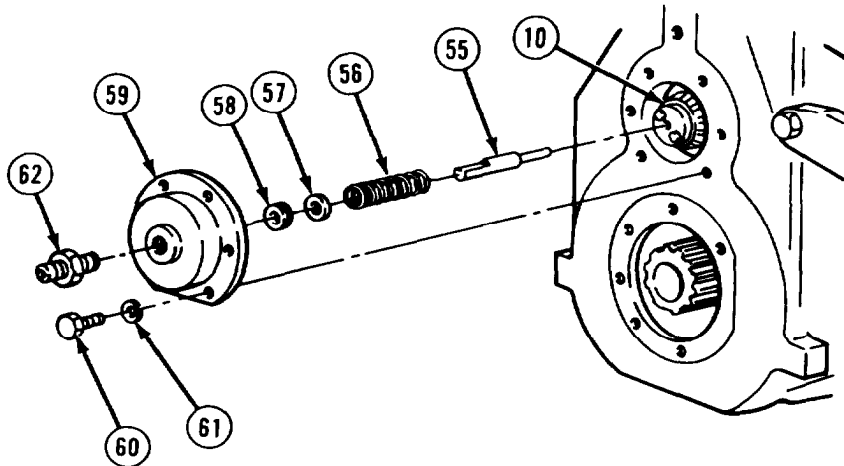

Transfer Case Maintenance Instructions (Cont)

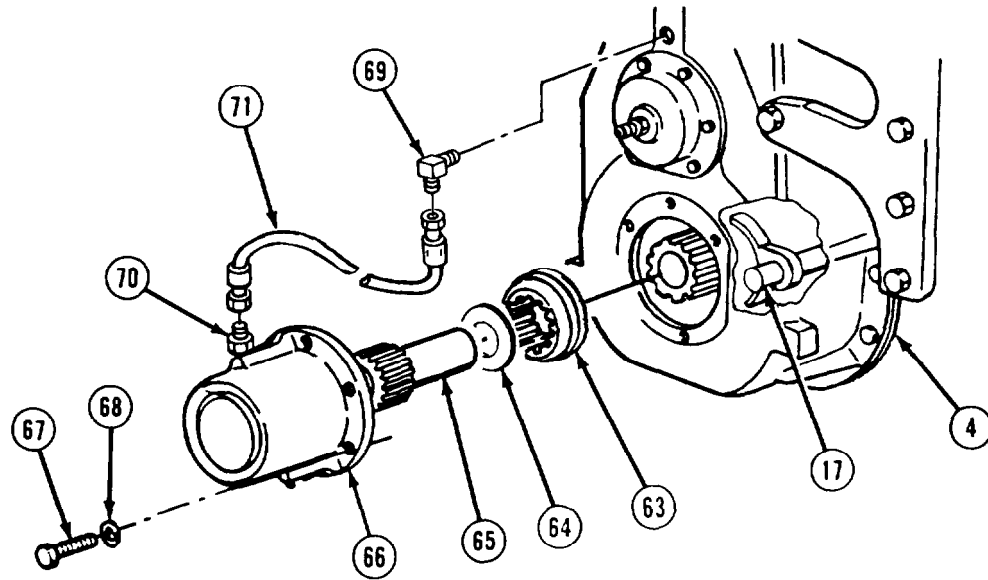

- (54) Turn workstand to place transfer case front half (4) in vertical position.
- (55) Coat groove in clutch collar (63) with grease.
- (56) Engage clutch collar (63) with lower shift rod assembly (17) so groove is in same location as noted at removal.
- (57) Install input shaft yoke spacer (64).

WARNING

Adhesives, solvents, and sealing compounds can burn easily, can give off harmful vapors, and are harmful to skin and clothing. To avoid injury or death, keep away from open fire and use in well-ventilated area. If adhesive, solvent, or sealing compound gets on skin or clothing, wash immediately with soap and water.

- (58) Coat end of lower front output shaft assembly (65) with grease. Coat inside flange of bearing cap (66) with adhesive and install.
- (59) Coat threads of six screws (67) with sealing compound and install lockwashers (68) and screws. Tighten screws to 60 lb-ft (81 N•m).
- (60) Coat thread of elbows (69 and 70) with pipe thread sealing compound and install elbows.
- (61) Install hose (71).

d. Follow-on Maintenance.

- (1) Install lubrication pump (para 8-15).
- (2) Install lockout shift chamber (para 8-14).
- (3) Install oil seals (para 8-5).
- (4) Install breather (TM 9-2320-279-20).

END OF TASK

Transfer Case Maintenance Instructions (Cont)

8-5. OIL SEAL REMOVAL/INSTALLATION

This task covers:

- a. Removal
- b. Installation
- c. Follow-on Maintenance

INITIAL SETUP

Models

All

Test Equipment

None

Special Tools

None

Supplies

Grease, automotive and artillery, Item 34, Appendix C
 Adhesive-sealant, silicone, Item 6, Appendix C
 Compound, sealing, Item 25, Appendix C

Personnel Required

MOS 63W, Wheel vehicle repairer

References

None

Equipment Condition

<i>TM or Para</i>	<i>Condition Description</i>
TM 9-2320-279-10	Shut off engine.
LO 9-2320-279-12	Transfer case oil drained.
TM 9-2320-279-20	Propeller shafts removed.

Special Environmental Conditions

None

General Safety Instructions

None

Level of Maintenance

Direct Support

a. Removal.

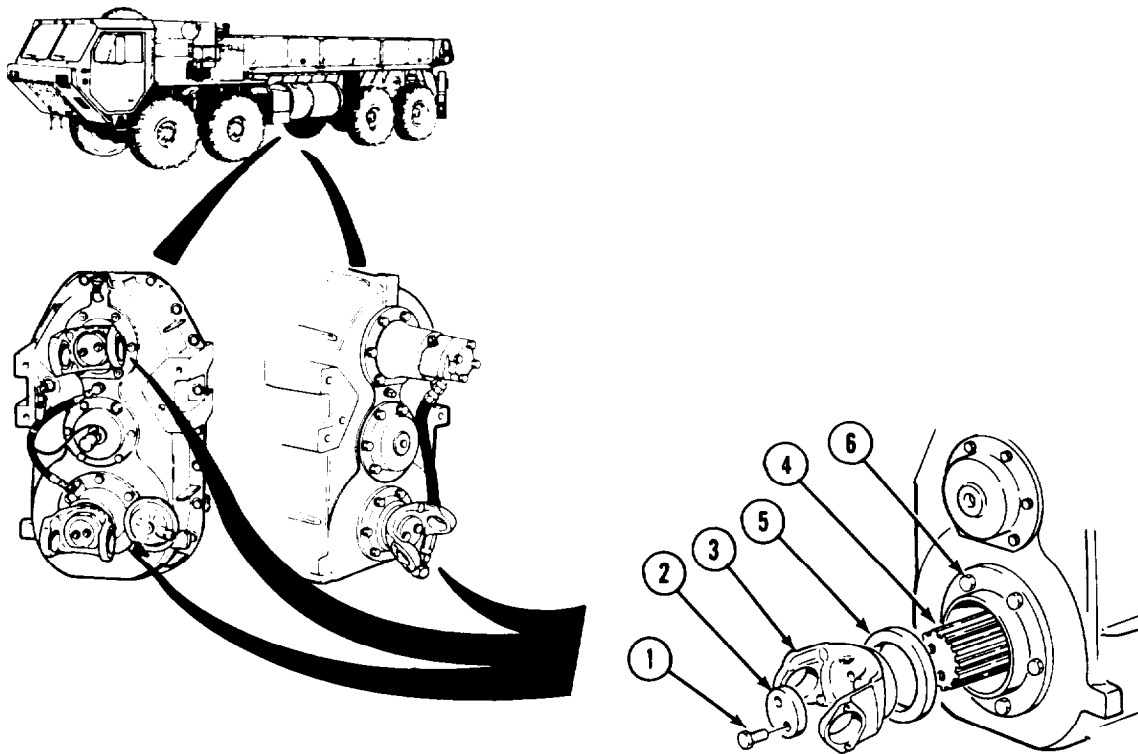

Transfer Case Maintenance Instructions (Cont)

NOTE

All three oil seals are removed and installed the same way.

- (1) Remove two screws (1) and retaining washer (2).
- (2) Remove yoke (3) from shaft (4).
- (3) Remove oil seal (5) from housing (6).

b. Installation.

- (1) Coat lip of oil seal (5) with grease.
- (2) Install oil seal (5) in housing (6).

WARNING

Adhesives, solvents, and sealing compounds can burn easily, can give off harmful vapors, and are harmful to skin and clothing. To avoid injury or death, keep away from open fire and use in well-ventilated area. If adhesive, solvent, or sealing compound gets on skin or clothing, wash immediately with soap and water.

- (3) Coat end and splined surface of shaft (4) with silicone adhesive-sealant.
- (4) Install yoke (3) and set yoke against shaft (4).

NOTE

Retaining screws may be either grade 5 or grade 8. Torque screws accordingly.

- (4.1) Apply sealing compound to threads of two screws (1).
- (5) Install retaining washer (2) and two screws (1). Tighten grade 8 screws to 88 lb-ft (119 N•m). Tighten grade 5 screws to 60 lb-ft (81 N•m).

c. Follow-on Maintenance.

- (1) Install propeller shafts (TM 9-2320-279-20).
- (2) Fill transfer case with oil (LO 9-2320-279-12).

END OF TASK

8-6. TOP INPUT SHAFT REPAIR.		
This task covers:		
a. Disassembly	c. Assembly	
b. Cleaning/Inspection	d. Follow-on Maintenance	
INITIAL SETUP	<i>References</i>	
<i>Models</i>	None	
All	<i>Equipment Condition</i>	
<i>Test Equipment</i>	<i>TM or Para</i>	<i>Condition Description</i>
None		Top input shaft on clean work surface.
<i>Special Tools</i>	<i>Special Environmental Conditions</i>	
None	None	
<i>Supplies</i>	<i>General Safety Instructions</i>	
Solvent, drycleaning, Item 57, Appendix C	None	
Oil, lubricating, Item 47, Appendix C	<i>Level of Maintenance</i>	
Grease, automotive and artillery, Item 34, Appendix C.	General Support	
Compound, sealing, Item 25, Appendix C		
Personnel Required		
MOS 63W, wheel vehicle repairer		

Transfer Case Maintenance Instructions (Cont)

8-6. TOP INPUT SHAFT REPAIR (CONT).

a. Disassembly.

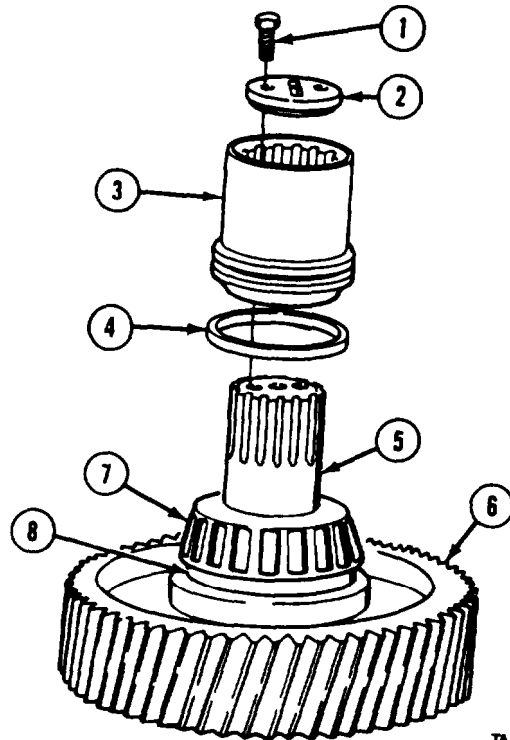

TA168908

- (1) Remove two screws (1) and pump drive plate (2).
- (2) Remove spacer (3) and piston ring (4).
- (3) Place top input shaft assembly (5) in suitable press with large gear (6) up.
- (4) Press top input shaft (5) out of bearing (7), spacer (8), and large gear (6).
- (5) Remove two needle bearings (9), spacer (10), spacer (11), and shift collar (12).

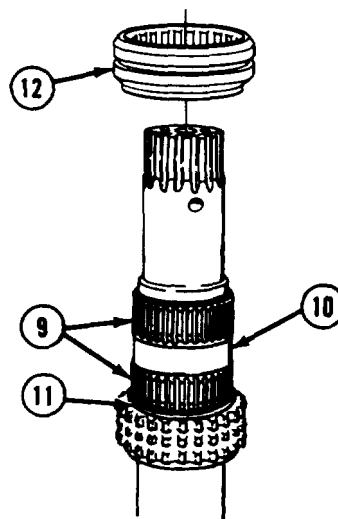

TA168905

Transfer Case Maintenance Instructions (Cont)

- (6) Turn top input shaft assembly over, and press top input shaft (5) out of bearing (13), spacer (14), and gear (15).

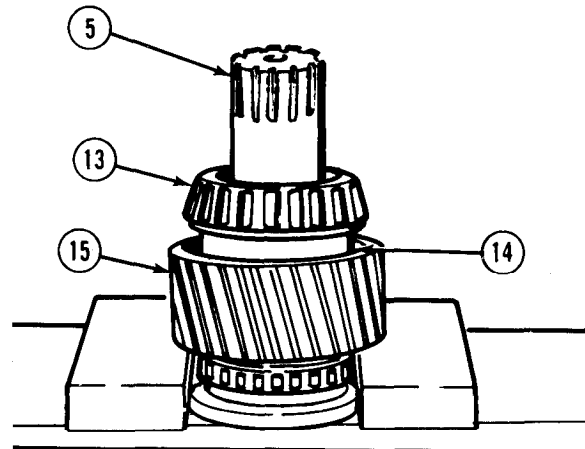

TA188912

- (7) Remove two needle bearings (16) and spacer (17).
- (8) Remove spacer (18).

b. Cleaning/Inspection.

WARNING

Adhesives, solvents, and sealing compounds can burn easily, can give off harmful vapors, and are harmful to skin and clothing. To avoid injury or death, keep away from open fire and use in well-ventilated area. If adhesive, solvent, or sealing compound gets on skin or clothing, wash immediately with soap and water.

- (1) Clean all metal parts in dry cleaning solvent.
- (2) Inspect all parts for wear or damage.
- (3) Remove nicks and burrs from machined surfaces with a fine mill file.
- (4) Replace all worn or damaged parts.

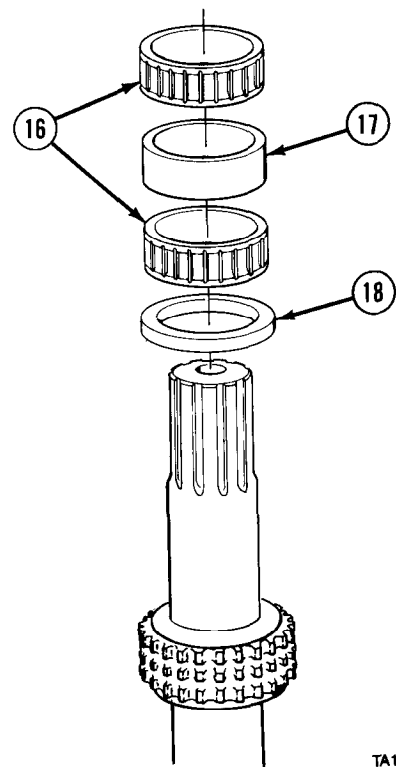

TA188906

8-6. TOP INPUT SHAFT REPAIR (CONT).

c. Assembly.

- (1) Place top input shaft (1) in press so long-spline end is up.
- (2) Install spacer (2), needle bearing (3), spacer (4), and second needle bearing.
- (3) Cover two needle bearings (3) with grease.

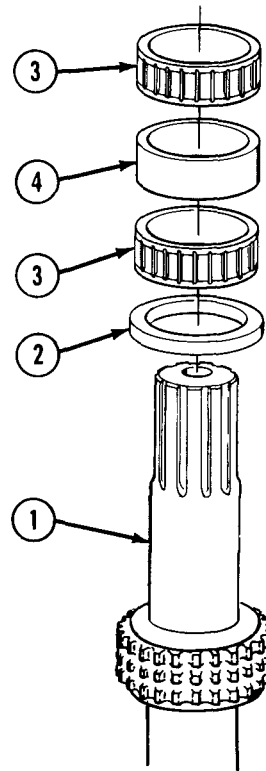

TA188910

- (4) Install gear (5) on top input shaft (1) and seat against spacer (2).
- (5) Install spacer (6).
- (6) Press bearing (7) to seat against spacer (6).

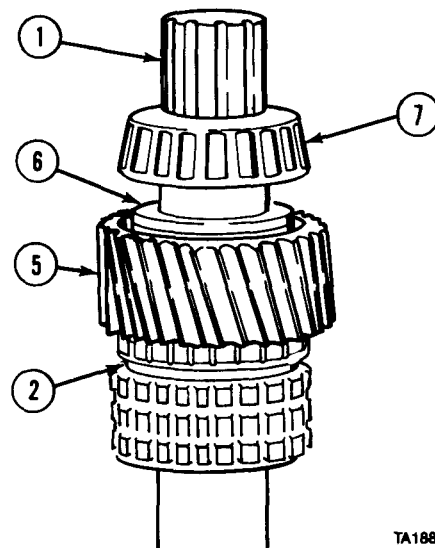

TA188911

Transfer Case Maintenance Instructions (Cont)

- (7) Turn top input shaft (1) over and install shaft collar (8) so larger taper is down.
- (8) Install gear spacer (9), needle bearing (10), spacer (11), and second needle bearing.
- (9) Coat two needle bearings (10) with grease.

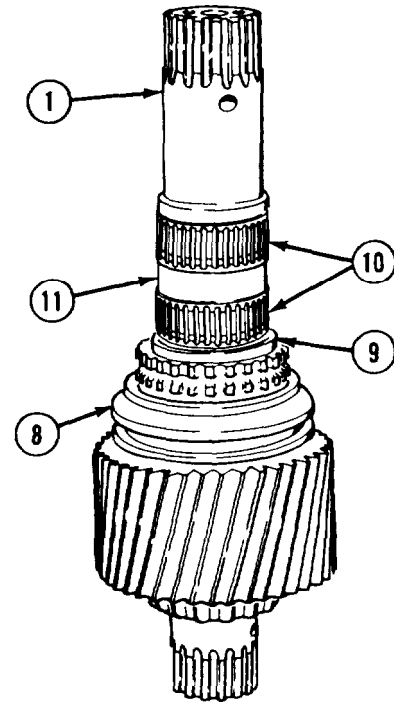

- (10) Install large gear (12) over top input shaft (1).
- (11) Install spacer (13).
- (12) Press bearing (14) to seat against spacer (13).
- (13) Install spacer (15) and piston ring (16).
- (14) Install pump drive plate (17).

NOTE

Retaining screws may be either grade 5 or grade 8. Torque screws accordingly.

- (15) Coat threads of two screws (18) with sealing compound and install. Tighten grade 8 screws to 88 lb-ft (119 N•m). Tighten grade 5 screws to 60 lb-ft (81 N•m).

d. Follow-on Maintenance. None.

END OF TASK

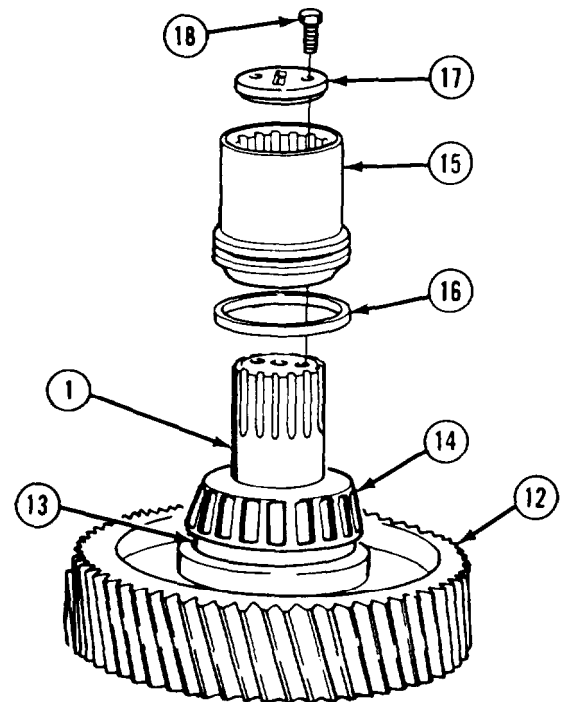

Transfer Case Maintenance Instructions (Cont)

8-7. CENTER SHAFT REPAIR

This task covers:

- | | |
|------------------------|--------------------------|
| a. Disassembly | c. Assembly |
| b. Cleaning/Inspection | d. Follow-on Maintenance |

INITIAL SETUP

Models
All

References
None

Test Equipment
None

Equipment Condition
TM or Para *Condition Description*
Center shaft on clean work surface.

Special Tools
None

Special Environmental Conditions
None

Supplies
Compound, sealing, Item 26, Appendix C
Solvent, drycleaning, Item 57, Appendix C

General Safety Instructions
None

Personnel Required
MOS 63W, Wheel vehicle repairer

Level of Maintenance
General Support

a. Disassembly.

- (1) Remove two screws (1) and retainer washer (2) from end of center shaft (3).

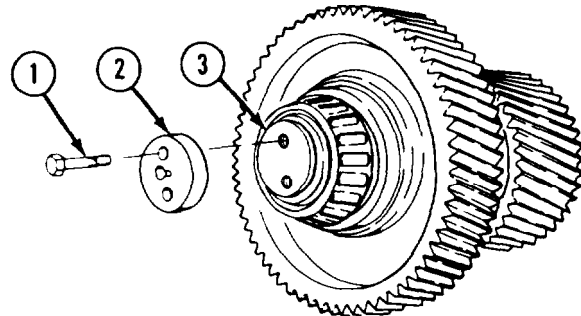

- (2) Place center shaft assembly in suitable press with large gear (4) up.
 (3) Press center shaft (3) out of bearing cone (5), spacer (6), and large gear (4).
 (4) Remove spacer (7) from center shaft (3).

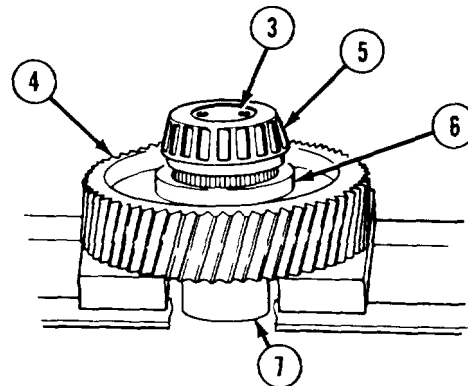

Transfer Case Maintenance Instructions (Cont)

- (5) Turn center shaft (3) over in press.
- (6) Press center shaft (3) out of bearing cone (8), spacer (9), and small gear (10).

b. Cleaning/Inspection.

WARNING

Adhesives, solvents, and sealing compounds can burn easily, can give off harmful vapors, and are harmful to skin and clothing. To avoid injury or death, keep away from open fire and use in well-ventilated area. If adhesive, solvent, or sealing compound gets on skin or clothing, wash immediately with soap and water.

- (1) Clean all metal parts in dry cleaning solvent.
- (2) Inspect all parts for wear or damage.
- (3) Remove all nicks and burrs from machined surfaces.
- (4) Replace all worn or damaged parts.

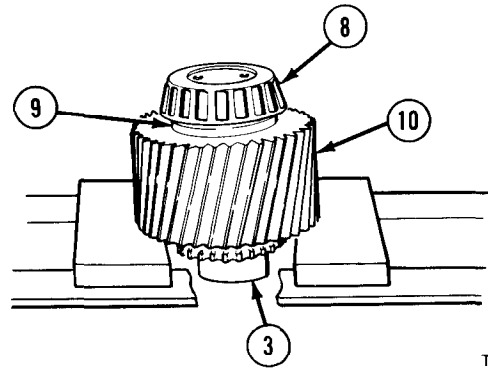

TA189093

c. Assembly.

- (1) Place center shaft (1) on clean work surface and press large gear (2) over short spline end of center shaft.
- (2) Install spacer (3) and seat against large gear (2).
- (3) Using sleeve driver, press bearing cone (4) on center shaft (1) and seat against spacer (3).

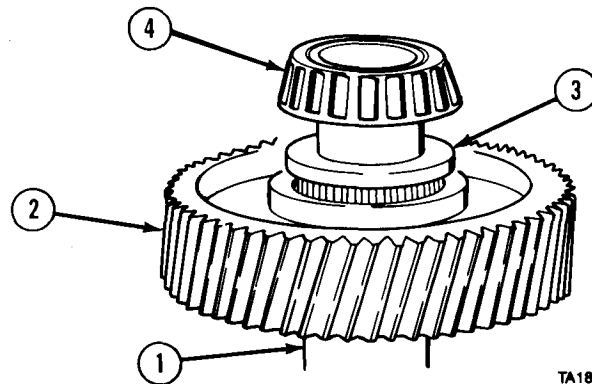

TA189084

WARNING

Adhesives, solvents, and sealing compounds can burn easily, can give off harmful vapors, and are harmful to skin and clothing. To avoid injury or death, keep away from open fire and use in well-ventilated area. If adhesive, solvent, or sealing compound gets on skin or clothing, wash immediately with soap and water.

- (4) Apply sealing compound to holes in retainer washer (5) and two screws (6).
- (5) Install retainer washer (5) and two screws (6). Tighten screws to 40 lb-ft (54 N·m).

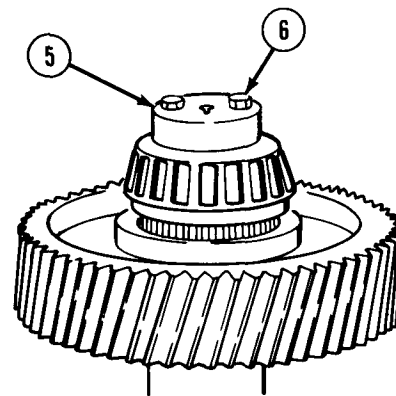

TA189085

Transfer Case Maintenance Instructions (Cont)

8-7. CENTER SHAFT REPAIR (CONT).

- (6) Turn center shaft (1) over and install spacer (7).
- (7) Press small gear (8) on center shaft (1) and install spacer (9).
- (8) Install bearing cone (10) to seat against spacer (9).

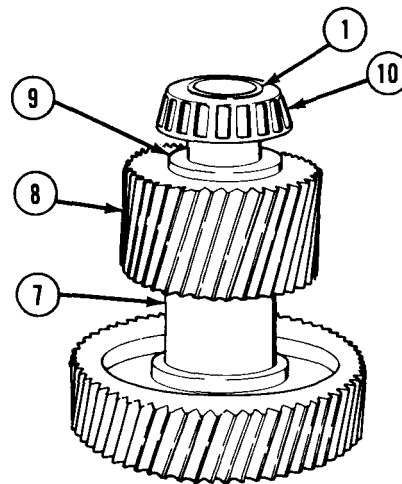

TA189098

d. Follow-on Maintenance. None.

END OF TASK

8-8. LOWER REAR OUTPUT SHAFT REPAIR.	
This task covers:	
a. Disassembly	c. Assembly
b. Cleaning/Inspection	d. Follow-on Maintenance
INITIAL SETUP	
<i>Models</i>	<i>References</i>
All	None
<i>Test Equipment</i>	<i>Equipment Condition</i>
None	<i>TM or Para</i> <i>Condition Description</i>
<i>Special Tools</i>	Lower rear output shaft on clean work surface.
None	
<i>Supplies</i>	<i>Special Environmental Conditions</i>
Solvent, dry cleaning, Item 57, Appendix C	None
Grease, automotive and artillery, Item 34, Appendix C	<i>General Safety Instructions</i>
	None
<i>Personnel Required</i>	<i>Level of Maintenance</i>
MOS 63W, Wheel vehicle repairer	General Support

Transfer Case Maintenance Instructions (Cont)

a. Disassembly.

- (1) Place lower rear output shaft assembly (1) in press with supports under gear (2).
- (2) Press lower rear output shaft (1) out of bearing cone (3), spacer (4), and gear (2).

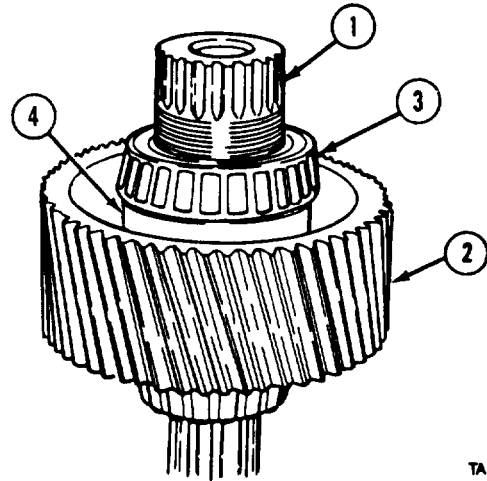

TA189180

- (3) Turn lower rear output shaft (1) over and press out of bearing cone (6).

b. Cleaning/Inspection.

WARNING

Adhesives, solvents, and sealing compounds can burn easily, can give off harmful vapors, and are harmful to skin and clothing. To avoid injury or death, keep away from open fire and use in well-ventilated area. If adhesive, solvent, or sealing compound gets on skin or clothing, wash immediately with soap and water.

- (1) Clean all metal parts in dry cleaning solvent.
- (2) Inspect all parts for wear or damage.
- (3) Remove all nicks and burrs from machined surfaces.
- (4) Replace all worn or damaged parts.

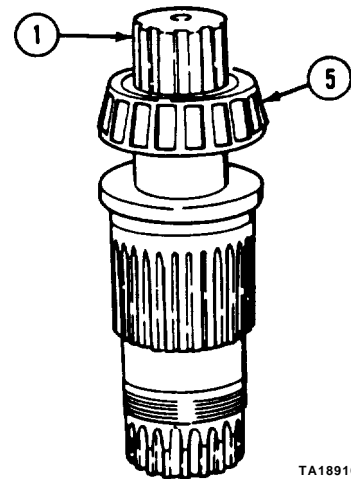

TA189163

c. Assembly.

- (1) Place lower rear output shaft (1) on clean work surface and install spacer (2).
- (2) Press bearing cone (3) on lower rear output shaft (1) and seat against spacer (2).
- (3) Coat bearing cone (3) with grease.

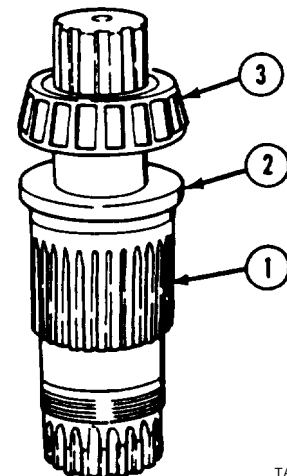

TA189162

Transfer Case Maintenance Instructions (Cont)

8-8. LOWER REAR OUTPUT SHAFT REPAIR (CONT).

- (4) Turn lower rear output shaft (1) over and press gear (4) on lower rear output shaft.
- (5) Press bearing (5) on lower rear output shaft (1) and set on gear (4).
- (6) Coat bearing (5) with grease.

d. Follow-on Maintenance. None

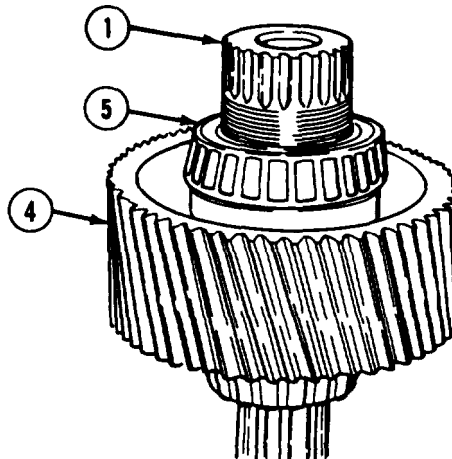

END OF TASK

8-9. LOWER FRONT OUTPUT SHAFT REPAIR.	
This task covers:	
a. Disassembly	c. Assembly
b. Cleaning/Inspection	d. Follow-on Maintenance
INITIAL SETUP	
<i>Models</i> All	<i>References</i> None
<i>Test Equipment</i> None	<i>Equipment Condition</i> TM or Para
<i>Special Tools</i> None	<i>Condition Description</i> Lower front output shaft on clean work surface.
<i>Supplies</i> Solvent, drycleaning, Item 57, Appendix C Compound, sealing, pipe thread, Item 28.1, Appendix C	<i>Special Environmental Conditions</i> None
<i>Personnel Required</i> MOS 63W, Wheel vehicle repairer	<i>General Safety Instructions</i> None
	<i>Level of Maintenance</i> General Support

Transfer Case Maintenance Instructions (Cont)

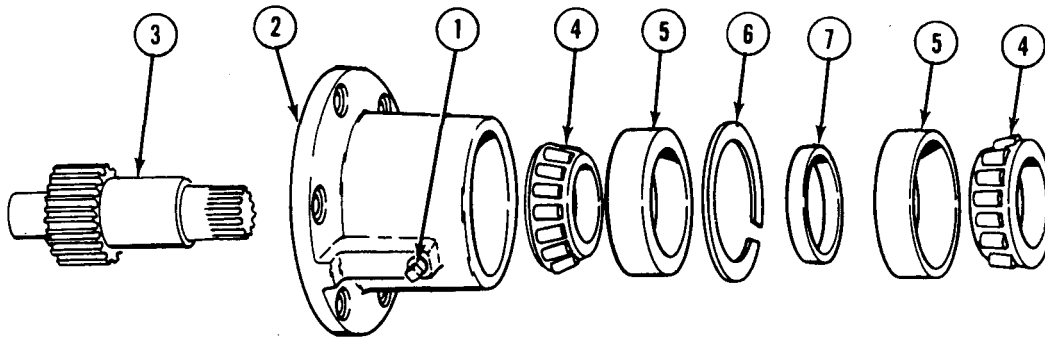
a. Disassembly.

TA189154

- (1) Remove plug (1).
- (2) Place bearing cap (2) in suitable press and press out output shaft (3).
- (3) Remove two bearing cones (4).
- (4) Press out two bearing cups (5), remove retaining ring (6), and spacer (7).

b. Cleaning/Inspection.**WARNING**

Adhesives, solvents, and sealing compounds can burn easily, can give off harmful vapors, and are harmful to skin and clothing. To avoid injury or death, keep away from open fire and use in well-ventilated area. If adhesive, solvent, or sealing compound gets on skin or clothing, wash immediately with soap and water.

- (1) Clean all metal parts in dry cleaning solvent.
- (2) Inspect all parts for wear or damage.
- (3) Remove all nicks and burrs from machined surfaces.
- (4) Replace all worn or damaged parts.

c. Assembly.

- (1) Install retaining ring (1) in bearing cap (2).
- (2) Install two bearing cups (3) and seat against retaining ring (1).

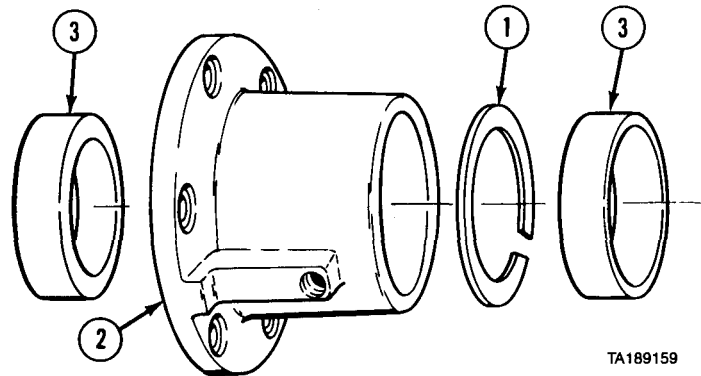

TA189159

8-9. LOWER FRONT OUTPUT SHAFT REPAIR (CONT).

- (3) Place inner bearing cone (4) on spline end of output shaft (5). Press to seat against shoulder of shaft.
- (4) Install spacer (6).

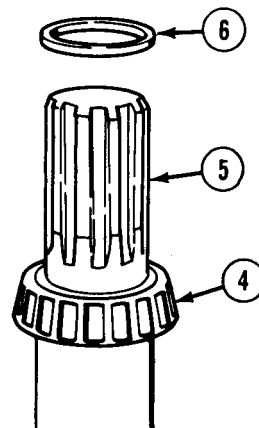

TA189156

- (5) Install bearing cap (2) on splined end of output shaft (5) until inner bearing cone (4) is firmly seated in bearing cup (3).
- (6) Place outer bearing cone (7) on spline end of output shaft (5).
- (7) Press to seat outer bearing cone (7) in outer bearing cup (3).

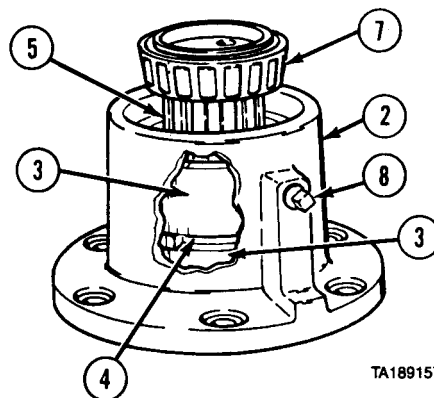

TA189157

WARNING

Adhesives, solvents, and sealing compounds can burn easily, can give off harmful vapors, and are harmful to skin and clothing. To avoid injury or death, keep away from open fire and use in well-ventilated area. If adhesive, solvent, or sealing compound gets on skin or clothing, wash immediately with soap and water.

- (8) Coat threads of plug (8) with pipe thread sealing compound and install plug.

d. Follow-on Maintenance. None.

END OF TASK

Transfer Case Maintenance Instructions (Cont)

8-10. UPPER SHIFT ROD ASSEMBLY REPAIR.	
This task covers:	
a. Disassembly	c. Assembly
b. Cleaning/Inspection	d. Follow-on Maintenance
INITIAL SETUP	
<i>Models</i> All	<i>References</i> None
<i>Test Equipment</i> None	<i>Equipment Condition</i> TM or Para
<i>Special Tools</i> None	<i>Condition Description</i> Upper shift rod assembly on clean work surface.
<i>Supplies</i> Solvent, drycleaning, Item 57, Appendix C Oil, lubricating, Item 46, Appendix C Lockwire, Item 39, Appendix C Compound, sealing, Item 26, Appendix C	<i>Special Environmental Conditions</i> None
<i>Personnel Required</i> MOS 63W, Wheel vehicle repairer	<i>General Safety Instructions</i> None
	<i>Level of Maintenance</i> General Support

a. Disassembly.

NOTE

Spacers are different in length. Mark for proper assembly.

- (1) Remove two spacers (1 and 2) from shift rod (3).
- (2) Cut lockwire (4) holding two screws (5).
- (3) Remove two screws (5) from fork (6).
- (4) Remove shift rod (3) from fork (6).

b. Cleaning/inspection.

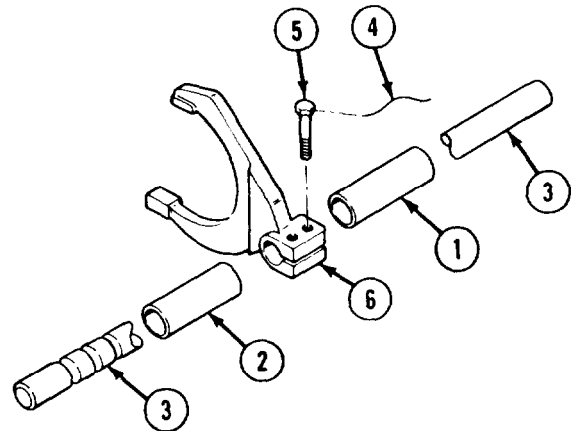

WARNING

Adhesives, solvents, and sealing compounds can burn easily, can give off harmful vapors, and are harmful to skin and clothing. To avoid injury or death, keep away from open fire and use in well-ventilated area. If adhesive, solvent, or sealing compound gets on skin or clothing, wash immediately with soap and water.

- (1) Clean all metal parts in drycleaning solvent.
- (2) Inspect all parts for wear or damage.
- (3) Replace all worn or damaged parts.

Transfer Case Maintenance Instructions (Cont)

8.10. UPPER SHIFT ROD ASSEMBLY REPAIR (CONT).

c. Assembly.

(1) Slide shift rod (1) in fork (2).

WARNING

Adhesives, solvents, and sealing compounds can burn easily, can give off harmful vapors, and are harmful to skin and clothing. To avoid injury or death, keep away from open fire and use in well-ventilated area. If adhesive, solvent, or sealing compound gets on skin or clothing, wash immediately with soap and water.

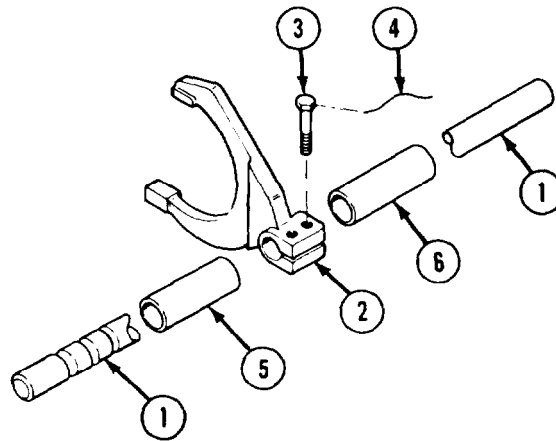

- (2) Coat threads of two screws (3) with sealing compound,
- (3) Install two screws (3). Tighten screws to 40 lb-ft (54 N•m).
- (4) Secure two screws (3) together with lockwire (4).
- (5) Install two spacers (5 and 6) on shift rod (1).

d. Follow-on Maintenance. None.

END OF TASK

8-11. LOWER SHIFT ROD ASSEMBLY REPAIR.	
This task covers:	
a. Disassembly	c. Assembly
b. Cleaning/Inspection	d. Follow-on Maintenance
INITIAL SETUP	
<i>Models</i> All	<i>References</i> None
<i>Test Equipment</i> None	<i>Equipment Condition</i> TM or Para
<i>Special Tools</i> None	<i>Condition Description</i> Upper shift rod assembly on clean work surface,
<i>Supplies</i> Solvent, drycleaning, Item 57, Appendix C Oil, lubricating, Item 46, Appendix C Lockwire, Item 39, Appendix C Compound, sealing, Item 26, Appendix C Grease, lithium, Item 36, Appendix C	<i>Special Environmental Conditions</i> None
<i>Personnel Required</i> MOS 63W, Wheel vehicle repairer	<i>General Safety Instructions</i> None
	<i>Level of Maintenance</i> General Support

Transfer Case Maintenance Instructions (Cont)

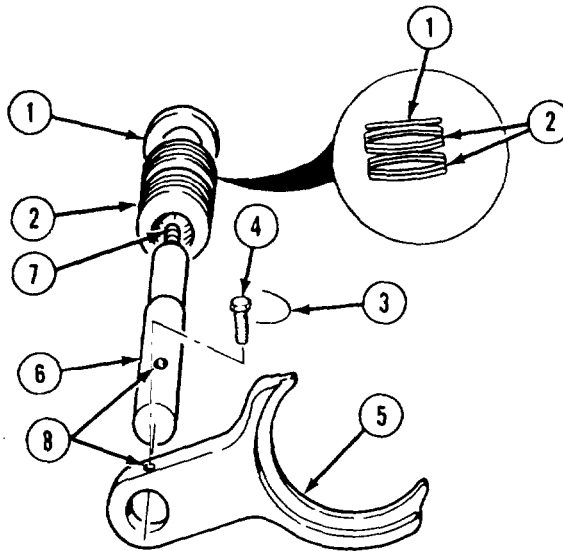
a. *Disassembly.*

- (1) Remove spacer (1) and eight spring disks (2).
- (2) Cut lockwire (3) holding screw (4).
- (3) Remove screw (4) from fork (5).
- (4) Slide shift rod (6) from fork (5).
- (5) Remove stud (7) from shift rod (6).

b. *Cleaning/Inspection.***WARNING**

Adhesives, solvents, and sealing compounds can burn easily, can give off harmful vapors, and are harmful to skin and clothing. To avoid injury or death, keep away from open fire and use in well-ventilated area. If adhesive, solvent, or sealing compound gets on skin or clothing, wash immediately with soap and water.

- (1) Clean all metal parts in drycleaning solvent.
- (2) Inspect all parts for wear or damage.
- (3) Replace all worn or damaged parts.

c. *Assembly.*

- (1) Apply lithium grease to threads of stud (7) and install stud in shift rod (6). Tighten stud to 15 lb-ft (20 N•m).
- (2) Slide shift rod (6) in fork (5).
- (3) Coat threads of screw (4) with sealing compound.
- (4) Align holes (8) and install screw (4). Tighten screw to 40 lb-ft (54 N•m).
- (5) Secure screw (4) with lockwire (3).
- (6) Install eight spring disks (2), alternating concaved surfaces, in pairs.
- (7) Install spacer (1).

d. *Follow-on Maintenance.* None.

END OF TASK

Transfer Case Maintenance Instructions (Cont)

Section III. TRANSFER CASE CONTROLS

8-12. HI-LO RANGE TRANSFER CASE LOCK-UP VALVE REPAIR.		
This task covers:		
a. Disassembly	c. Assembly	
b. Cleaning/Inspection	d. Follow-on Maintenance	
INITIAL SETUP		
<i>Models</i>	<i>Equipment Condition</i>	
All	TM or Para	<i>Condition Description</i>
<i>Test Equipment</i>		HI-LO range transfer case lock-up valve on clean work surface.
None		
<i>Special Tools</i>	<i>Special Environmental Conditions</i>	
None	None	
<i>Supplies</i>	<i>General Safety Instructions</i>	
Oil, lubricating, Item 48, Appendix C	None	
Solvent, dry cleaning, Item 57, Appendix C		
<i>Personnel Required</i>	<i>Level of Maintenance</i>	
MOS 63W, Wheel vehicle repairer	Direct Support	
<i>References</i>		
None		

a. Disassembly.

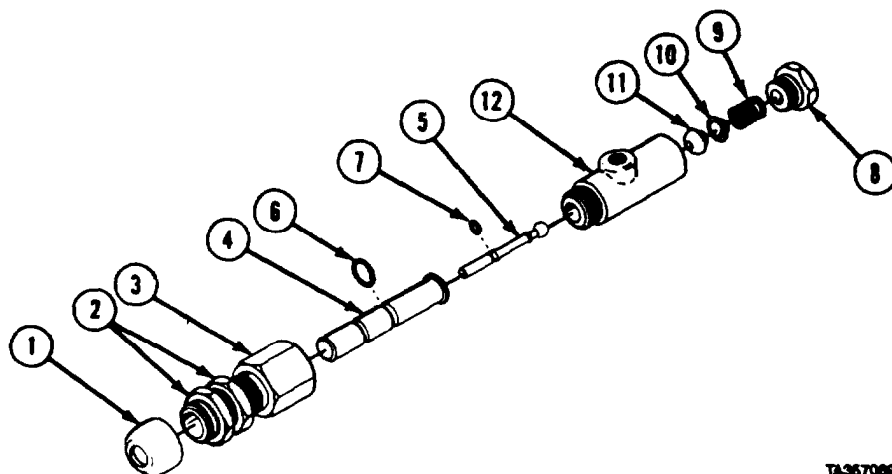

TA367008

- (1) Remove boot (1) and two nuts (2).
- (2) Remove adapter (3), plunger (4), valve stem (5), and two preformed packings (6 and 7).
- (3) Remove capnut (8), spring (9), seat (10), and inlet valve (11) from body (12).

Transfer Case Maintenance Instructions (Cont)

b. Cleaning/Inspection.

WARNING

Adhesives, solvents, and sealing compounds can burn easily, can give off harmful vapors, and are harmful to skin and clothing. To avoid injury or death, keep away from open fire and use in well-ventilated area. If adhesive, solvent, or sealing compound gets on skin or clothing, wash immediately with soap and water.

- (1) Clean all metal parts in dry cleaning solvent.
- (2) Inspect HI LO range transfer case lock-up valve for damage.
- (3) Replace damaged parts.

c. Assembly.

- (1) Install inlet valve (11), seat (10), spring (9), and capnut (8) in body (12).
- (2) Install two preformed packings (6 and 7), valve stem (5), plunger (4), and adapter (3).
- (3) Install two nuts (2) and boot (1) on adapter (3).

d. Follow-on Maintenance. None.

END OF TASK

8-13. TRACTION CONTROL VALVE REPAIR.		
This task covers:		
a. Disassembly	c. Assembly	
b. Cleaning/Inspection	d. Follow-on Maintenance	
INITIAL SETUP		
<i>Models</i>	<i>References</i>	
All	None	
<i>Test Equipment</i>	<i>Equipment Condition</i>	
None	<i>TM or Para</i>	<i>Condition Description</i>
<i>Special Tools</i>		Traction control valve on clean work surface.
None		
<i>Supplies</i>	<i>Special Environmental Conditions</i>	
Solvent, dry cleaning, Item 57, Appendix C	None	
Oil, lubricating, Item 46, Appendix C	<i>General Safety Instructions</i>	
<i>Personnel Required</i>	None	
MOS 63W, Wheel vehicle repairer	<i>Level of Maintenance</i>	
	Direct Support	

Transfer Case Maintenance Instructions (Cont)

8-13. TRACTION CONTROL VALVE REPAIR (CONT).

a. Disassembly.

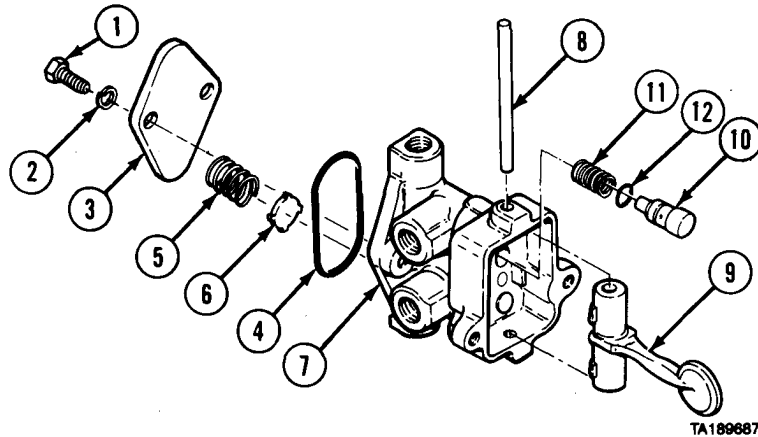

- (1) Remove two screws (1), lockwashers (2), cover (3), preformed packing (4), two springs (5), and control valves (6) from traction control valve body (7).
- (2) Drive dowel pin (8) from traction control valve body (7) and remove control valve lever (9), two plungers (10), and springs (11).
- (3) Remove two preformed packings (12) from plungers (10).

b. Cleaning/Inspection.

WARNING

Adhesives, solvents, and sealing compounds can burn easily, can give off harmful vapors, and are harmful to skin and clothing. To avoid injury or death, keep away from open fire and use in well-ventilated area. If adhesive, solvent, or sealing compound gets on skin or clothing, wash immediately with soap and water.

- (1) Clean all metal parts in dry cleaning solvent.
- (2) Inspect traction control valve body for damage.
- (3) Replace damaged parts.

c. Assembly.

- (1) Coat two preformed packings (12) with lubricating oil and install on two plungers (10).
- (2) Install two springs (11), plungers (10), and control valve lever (9) in traction control valve body (7) with dowel pin (8).
- (3) Coat preformed packing (4) with lubricating oil and install in traction control valve body (7).
- (4) Install two control valves (6), springs (5), cover (3), two lockwashers (2), and screws (1) in traction control valve body (7).

d. Follow-on Maintenance. None.

END OF TASK

Transfer Case Maintenance Instructions (Cont)

8-14. LOCKOUT SHIFT CHAMBER REMOVAL/REPAIR/INSTALLATION

This task covers:

- | | |
|------------------------|--------------------------|
| a. Removal | d. Assembly |
| b. Disassembly | e. Installation |
| c. Cleaning/Inspection | f. Follow-on Maintenance |

INITIAL SETUP

Models
All

Test Equipment
None

Special Tools
None

Supplies
Compound, sealing, pipe thread, Item 28.1, Appendix C
Tags, identification, Item 60, Appendix C
Solvent, drycleaning, Item 57, Appendix C
Oil, lubricating, Item 46, Appendix C
Compound, sealing, Item 26, Appendix C
Adhesive, Item 8, Appendix C

Personnel Required
MOS 63W, Wheel vehicle repairer (2)

References
None

Equipment Condition
TM or Para Condition Description
TM 9-2320-279-10 Shut off engine.

Special Environmental Conditions
None

General Safety Instructions
Wheels chocked.

Level of Maintenance
Direct Support

a. Removal.

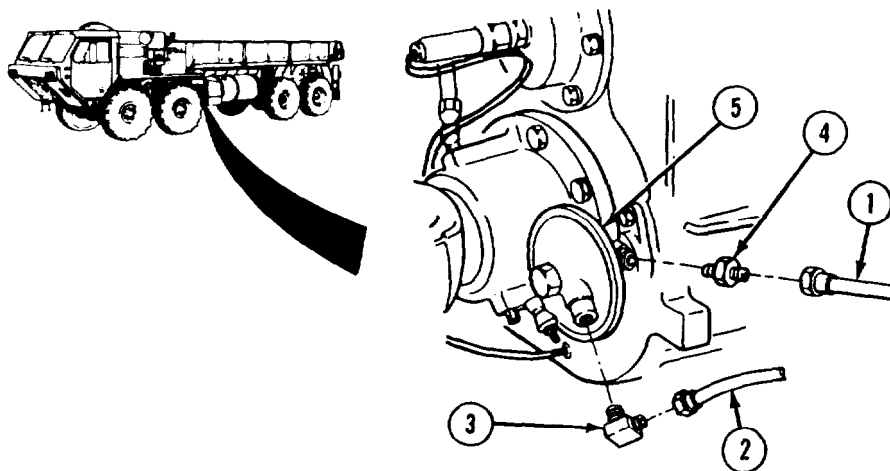

NOTE

Tag and mark airhoses before disconnecting.

- (1) Disconnect two airhoses (1 and 2).
- (2) Remove elbow (3) and connector (4) from chamber body (5).

Transfer Case Maintenance Instructions (Cont)

8-14. LOCKOUT SHIFT CHAMBER REMOVAL/REPAIR/INSTALLATION (CONT).

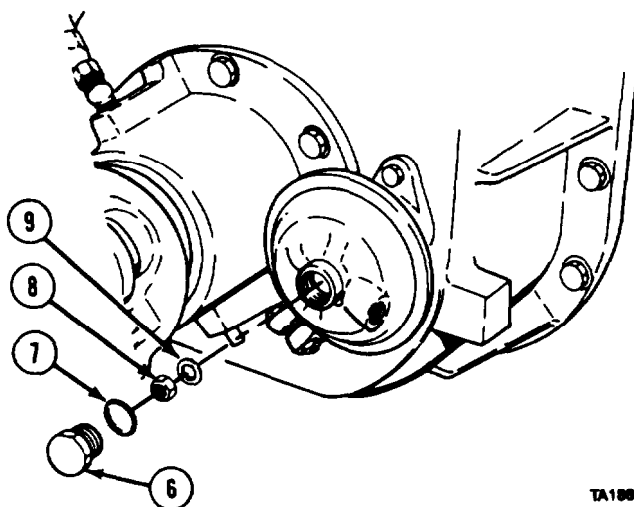

- (3) Remove plug (6) and preformed packing (7).
- (4) Remove locknut (8) and copper washer (9).

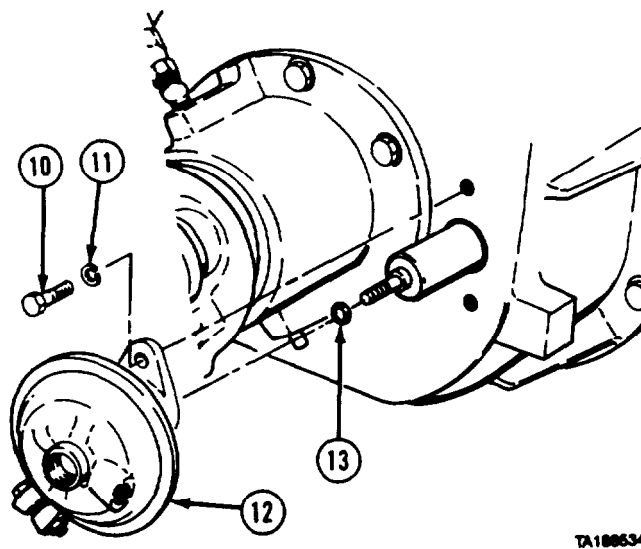

- (5) Remove two screws (10), lockwashers (11), lockout shift chamber (12), and copper washer (13).

Transfer Case Maintenance Instructions (Cont)

b. Disassembly.

WARNING

Spring inside chamber is under load. Remove ring clamp carefully to avoid personal injury.

NOTE

A vise may be used to relieve spring pressure when disassembling chamber.

- (1) Remove two nuts (1) and screws (2).
- (2) Remove ring clamp (3) and open vise.
- (3) Remove front cover (4).

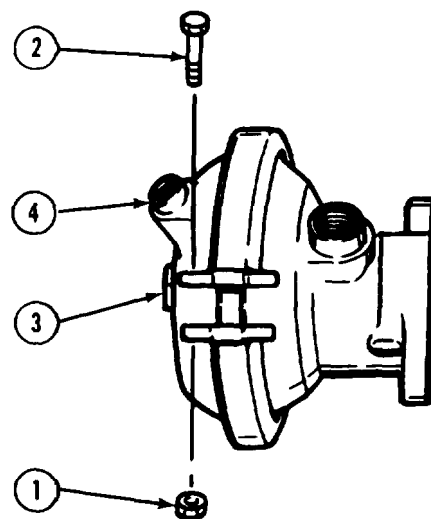

- (4) Remove diaphragm (5) and spring (6).
- (5) Remove pilot ring (7) and seal (8) from rear of chamber body (9).
- (6) Deleted.

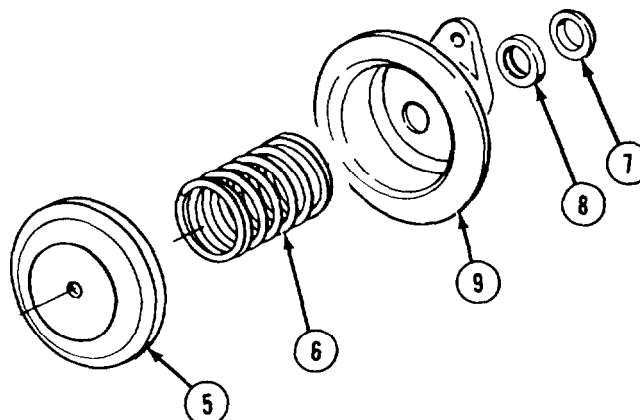

- (7) Remove nut (11), guide (12), and diaphragm (13) from air pressure plate (14).

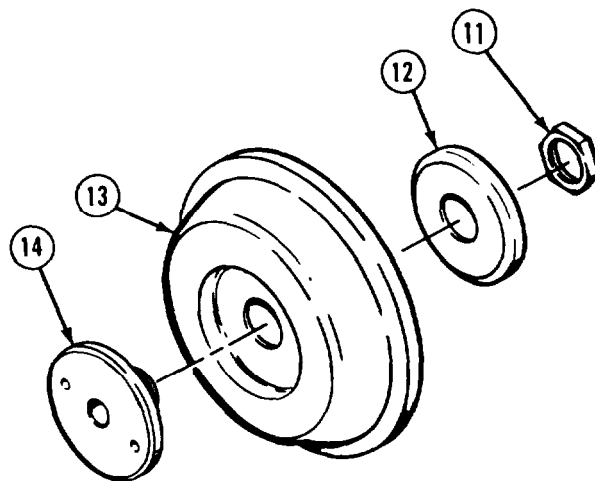

Transfer Case Maintenance Instructions (Cont)

8-14. LOCKOUT SHIFT CHAMBER REMOVAL/REPAIR/INSTALLATION (CONT).

c. Cleaning/Inspection.

WARNING

Adhesives, solvents, and sealing compounds can burn easily, can give off harmful vapors, and are harmful to skin and clothing. To avoid injury or death, keep away from open fire and use in well-ventilated area. If adhesive, solvent, or sealing compound gets on skin or clothing, wash immediately with soap and water.

- (1) Clean all metal parts in drycleaning solvent.
- (2) Inspect all metal parts for damage.
- (3) Replace damaged parts.

d. Assembly.

- (1) Install diaphragm (1), guide (2), and nut (3) on air pressure plate (4).

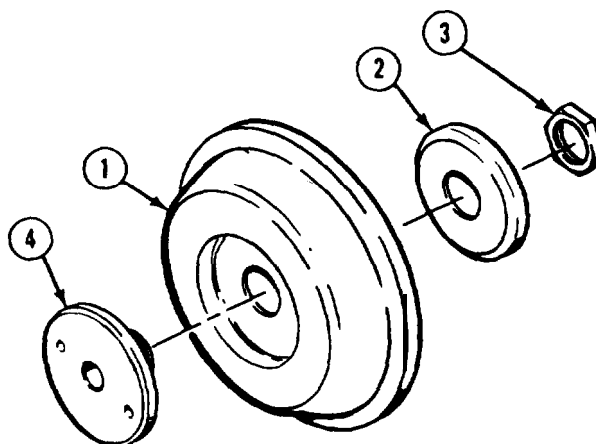

- (2) Install seal (5) and pilot ring (6) in rear of chamber body (7).

WARNING

Adhesives, solvents, and sealing compounds can burn easily, can give off harmful vapors, and are harmful to skin and clothing. To avoid injury or death, keep away from open fire and use in well-ventilated area. If adhesive, solvent, or sealing compound gets on skin or clothing, wash immediately with soap and water.

- (3) Coat rear of chamber body (7) with adhesive.

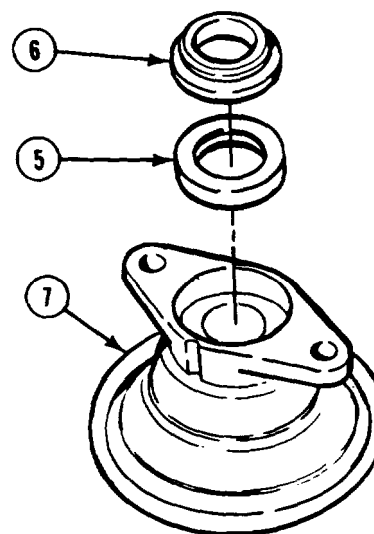

Transfer Case Instructions (Cont)

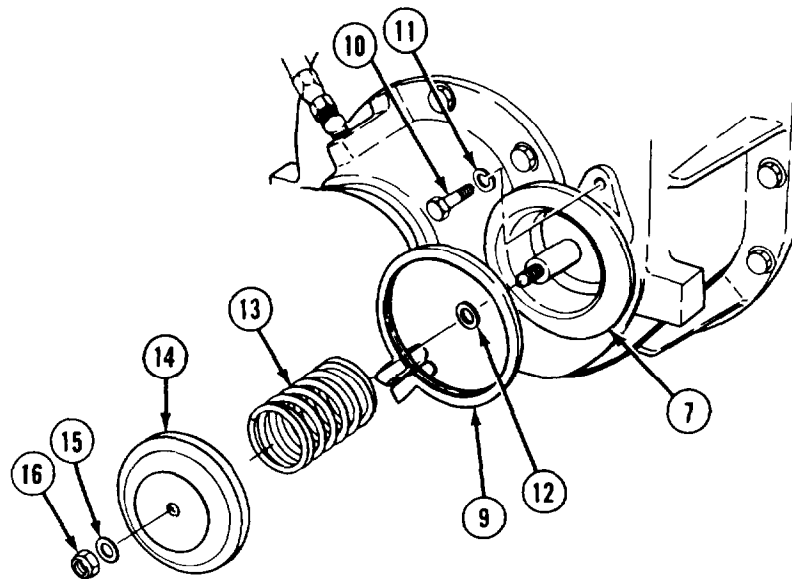

- (4) Place ring clamp (9) on rear part of chamber body (7).

WARNING

Adhesives, solvents, and sealing compounds can burn easily, can give off harmful vapors, and are harmful to skin and clothing. To avoid injury or death, keep away from open fire and use in well-ventilated area. If adhesive, solvent, or sealing compound gets on skin or clothing, wash immediately with soap and water.

- (5) Coat threads of two screws (10) with sealing compound and install screws, lockwashers (11), and rear part of chamber body (7).

NOTE

Check that shifter shaft is completely out.

- (6) Soldier A installs copper washer (12), spring (13), and pushes diaphragm assembly (14) towards chamber body (7) while Soldier B installs copper washer (15) and locknut (16).

e. Installation.

- (1) Press cover (1) in ring clamp (2) and install two screws (3) and nuts (4).
 (2) Install preformed packing (5) and plug (6).

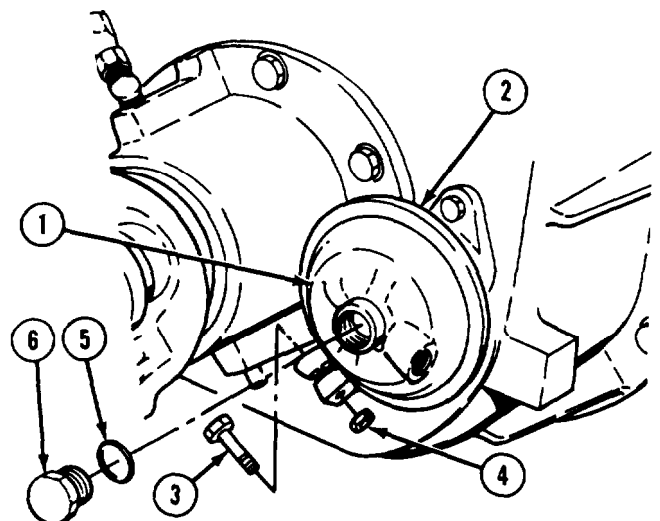

Transfer Case Maintenance Instructions (Cont)

8-14. LOCKOUT SHIFT CHAMBER REMOVAL/REPAIR/INSTALLATION (CONT).

WARNING

Adhesives, solvents, and sealing compounds can burn easily, can give off harmful vapors, and are harmful to skin and clothing. To avoid injury or death, keep away from open fire and use in well-ventilated area. If adhesive, solvent, or sealing compound gets on skin or clothing, wash immediately with soap and water.

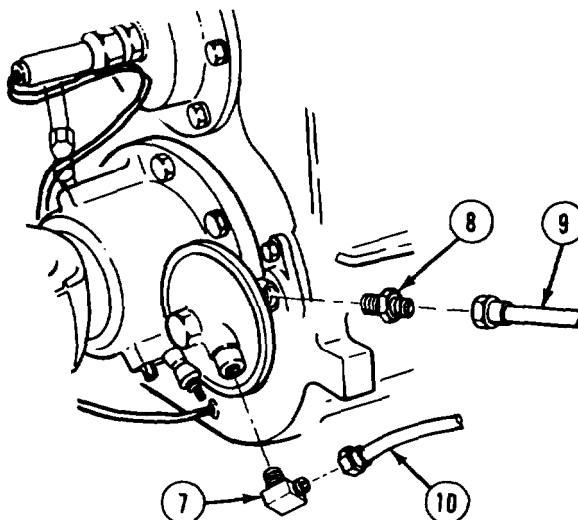

- (3) Coat threads of elbow (7) and connector (8) with pipe thread sealing compound.
- (4) Install elbow (7).
- (5) Install connector (8).
- (6) Connect two airhoses (9 and 10).

f. **Follow-on Maintenance.** Start engine, build up air pressure, check for leaks (TM 9-2320-279-10).

END OF TASK

8-15. LUBRICATION PUMP REMOVAL/INSTALLATION.	
This task covers:	
a. Removal	c. Follow-on Maintenance
b. Installation	
INITIAL SETUP	
<i>Models</i> All	<i>References</i> None
<i>Test Equipment</i> None	<i>Equipment Condition</i> TM or Para <i>Condition Description</i> TM 9-2320-279-10 Shut off engine.
<i>Special Tools</i> None	<i>Special Environmental Conditions</i> None
<i>Supplies</i> Compound, sealing, Item 26, Appendix C Compound, sealing, pipe thread, Item 28.1, Appendix C Adhesive, Item 8, Appendix C	<i>General Safety Instructions</i> None
<i>Personnel Required</i> MOS 63W, Wheel vehicle repairer	<i>Level of Maintenance</i> Direct Support

Transfer Case Maintenance Instructions (Cont)

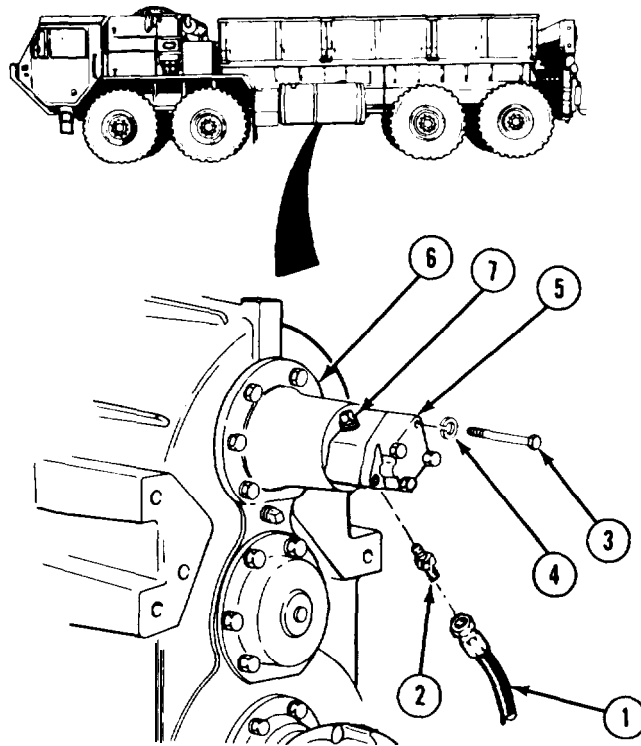
a. **Removal.**

- (1) Disconnect lubrication hose (1) from fitting (2).
- (2) Remove four screws (3) and lockwashers (4).
- (3) Remove lubrication pump (5) from bearing cover (6).
- (4) Remove fitting (2) from lubrication pump (5).
- (5) Remove plug (7).

b. **Installation.****WARNING**

Adhesives, solvents, and sealing compounds can burn easily, can give off harmful vapors, and are harmful to skin and clothing. To avoid injury or death, keep away from open fire and use in well-ventilated area. If adhesive, solvent, or sealing compound gets on skin or clothing, wash immediately with soap and water.

- (1) Coat pipe threads of fitting (2) with pipe thread sealing compound and install fitting in lubrication pump (5).
- (2) Coat pump mounting surface of bearing cover (6) with adhesive.
- (2.1) Apply sealing compound to threads of four screws (3).
- (3) Mount lubrication pump (5) on bearing cover (6) with four screws (3) and lockwashers (4). Tighten screws to 15 lb-ft (20 N•m).
- (4) Connect lubrication hose (1) to fitting (2).
- (5) Coat threads of plug (7) with pipe thread sealing compound and install plug.

c. **Follow-on Maintenance.** None.

END OF TASK

Transfer Case Maintenance Instructions (Cont)

8-16. LUBRICATION PUMP REPAIR.

This task covers:

- | | |
|------------------------|--------------------------|
| a. Disassembly | c. Assembly |
| b. Cleaning/Inspection | d. Follow-on Maintenance |

INITIAL SETUP

Models

All

Test Equipment

None

Special Tools

None

Supplies

Grease, automotive and artillery, Item 34, Appendix C
 Solvent, dry cleaning, Item 57, Appendix C
 Paper, abrasive, garnet, (emery cloth), Item 51, Appendix C

Personnel Required

MOS 63W, Wheel vehicle repairer

References

None

Equipment Condition

TM or Para

Condition Description

Lubrication pump on clean work surface.

Special Environmental Conditions

None

General Safety Instructions

None

Level of Maintenance

General Support

a. Disassembly.

- (1) Remove two screws (1), head (2) and gasket (3) from casing (4).
- (2) Remove two needle bearings (5) from head (2).
- (3) Remove gear (6) and shaft (7).
- (4) Remove shaft (8) with gear (9).

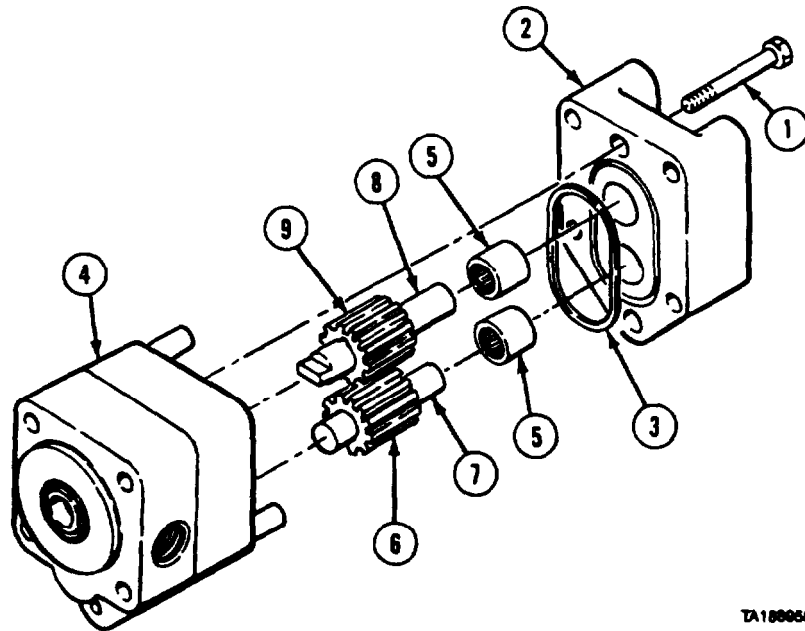

TA168058

Transfer Case Maintenance Instructions (Cont)

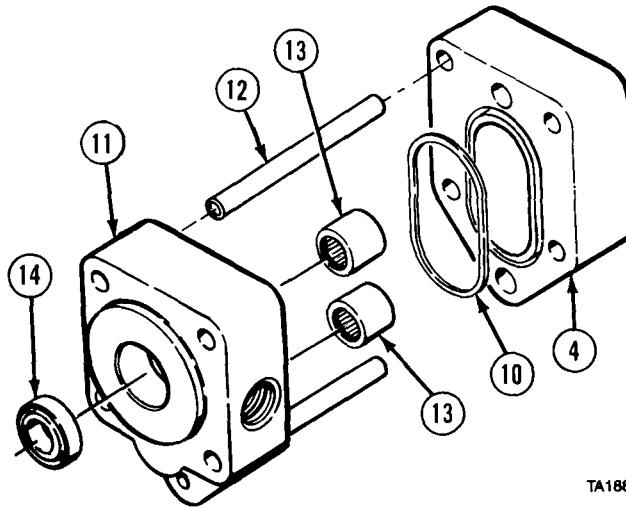

- (5) Remove casing (4) and gasket (10) from bracket (11).
- (6) Remove two alignment sleeves (12).
- (7) Remove two needle bearings (13).
- (8) Remove seal (14) from bracket (11).

b. Cleaning/Inspection.

WARNING

Adhesives, solvents, and sealing compounds can burn easily, can give off harmful vapors, and are harmful to skin and clothing. To avoid injury or death, keep away from open fire and use in well-ventilated area. If adhesive, solvent, or sealing compound gets on skin or clothing, wash immediately with soap and water.

- (1) Clean all metal parts in dry cleaning solvent.
- (2) Inspect all parts for wear or damage.
- (3) Remove light scoring by sanding with emery cloth.
- (4) Replace all worn or damaged parts.

c. Assembly.

NOTE

Install seal with lip toward bracket.

- (1) Coat seal (1) with grease and install in bracket (2).
- (2) Install two needle bearings (3) in bracket (2).
- (3) Install two alignment sleeves (4) in bracket (2).
- (4) Install gasket (5) on casing (6) and install casing on bracket (2).

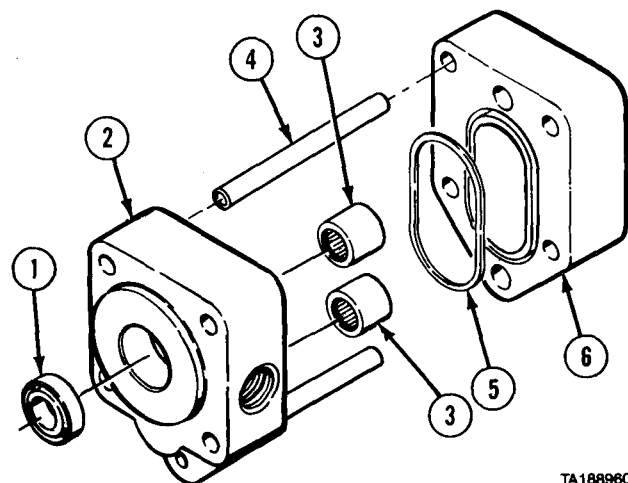

Transfer Case Maintenance Instructions (Cont)

8-16. LUBRICATION PUMP REPAIR (CONT).

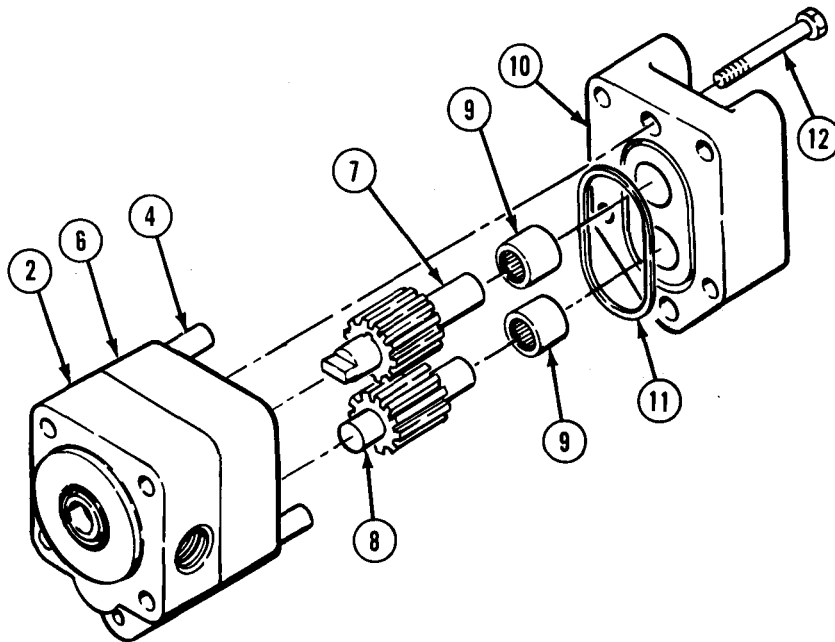

TA188961

- (5) Install shaft (7) in casing (6) and bracket (2) until end of shaft extends 1-5/8 in. (41.28 mm) beyond face of bracket.
- (6) Install shaft (8) in bracket (2).
- (7) Install two bearings (9) in head (10).
- (8) Coat gasket (11) with grease and install on head (10).
- (9) Align screw holes in head (10) with sleeves (4).
- (10) Install head (10) on casing (6) and bracket (2) with two screws (12).

d. Follow-on Maintenance. None.

END OF TASK

CHAPTER 9

AXLES NO. 1 AND NO. 2 MAINTENANCE

Contents	Para	Page
General	9-1	9-1
Axle Shaft Assembly Removal/Repair/Installation	9-2	9-2
Axle No. 1 Removal/Installation.	9-3	9-6
Axle No. 2 Removal/Installation.	9-4	9-10
Axle Housing Cover Assembly, Axle No. 2 Removal/Repair/Installation	9-5	9-14
Axles No. 1 and No. 2 Yoke and Oil Seal Removal/Installation	9-6	9-17
Differential Carrier, Axle No. 1 Removal/Installation	9-7	9-19
Differential Carrier Cover, Axle No. 2 Removal/Installation.. . . .	9-8	9-22
Differential Carrier Cover, Axle No. 2 Repair	9-9	9-26
Differential Carrier, Axle No. 2 Removal/Installation	9-10	9-35
Differential Carrier, Axle No. 1 Repair	9-11	9-38
Differential Carrier, Axle No. 2 Repair	9-12	9-56
Ball Socket Removal/Installation	9-13	9-82
Axles No. 1 and No. 2 Ball, Bushing, and Oil Seal Removal/Installation	9-14	9-94

Section I. INTRODUCTION

9-1. GENERAL. This chapter contains maintenance instructions for removal, installation, and repair of No. 1 and No. 2 axles at the direct support and general support maintenance level. The subassemblies and parts which must be removed before the axles and their components can be removed are referenced to other paragraphs or chapters of this manual or TM 9-2320-279-20.

Section II. AXLE ASSEMBLIES

Axles No. 1 and No. 2 Maintenance Instructions

9-2. AXLE SHAFT ASSEMBLY REMOVAL/REPAIR/INSTALLATION.	
This task covers:	
a. Removal	d. Assembly
b. Disassembly	e. Installation
c. Cleaning/Inspection	f. Follow-on Maintenance
INITIAL SETUP	
<i>Models</i>	<i>References</i>
All	None
<i>Test Equipment</i>	<i>Equipment Condition</i>
None	
<i>Special Tools</i>	<i>TM or Para</i> <i>Condition Description</i>
None	LO 9-2320-279-12 Axle drained.
	TM 9-2320-279-20 Front brakeshoes removed.
<i>Supplies</i>	<i>Special Environmental Conditions</i>
Grease, automotive and artillery, Item 34, Appendix C	None
Oil, lubricating, gear, Item 44, Appendix C	<i>General Safety Instructions</i>
Solvent, dry cleaning, Item 57, Appendix C	None
Adhesive-sealant, silicone, Item 6, Appendix C	<i>Level of Maintenance</i>
<i>Personnel Required</i>	Direct Support
MOS 63W, Wheel vehicle repairer	

a. Removal.

NOTE

Right and left axle shafts and cage ring assemblies are removed the same way. Right side is shown.

- (1) Remove 10 screws (1) from axle skein (2), brake spider (3), and ball socket (4).

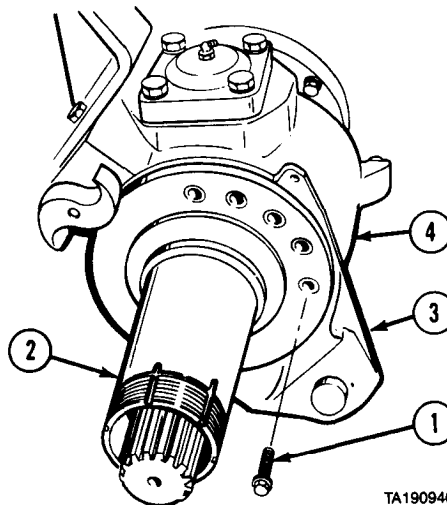

Axles No. 1 and No. 2 Maintenance Instructions (Cont)

- (2) Matchmark axle skein (2), brake spider (3), and ball socket (4).

NOTE

- It may be necessary to adjust brake camshaft to remove axle skein,
 - Pin should not be removed unless necessary
- (3) Remove axle skein (2), brake spider (3), and pin (4.1) from axle shaft assembly (5).
 - (4) Remove brake spider (3) from axle skein (2).
 - (5) Remove axle shaft assembly (5) from ball socket (4).

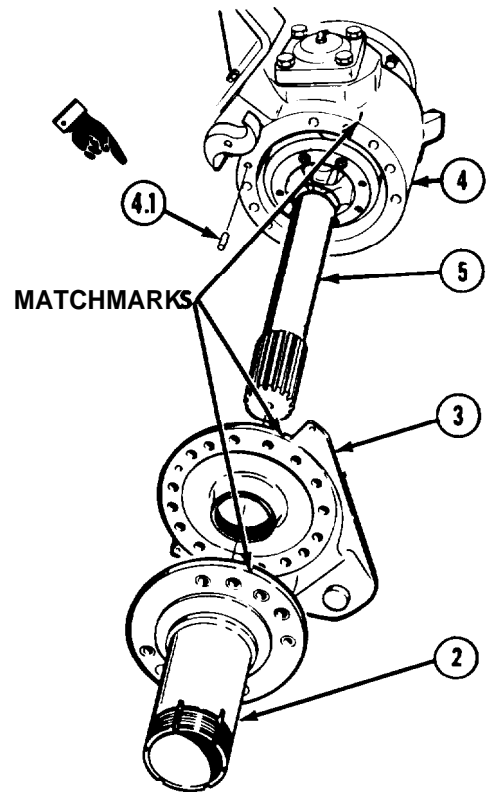

b. Disassembly.

CAUTION

Before splitting cage ring, axle shafts and cage ring halves must be marked to insure correct assembly. Cage ring halves sometimes have dowel pins to insure proper assembly, but shafts can be assembled improperly into cage ring itself. Axle shaft yoke trunnion must be replaced into same cage ring holes in order to insure proper operation.

- (1) Matchmark both halves of cage ring (1).

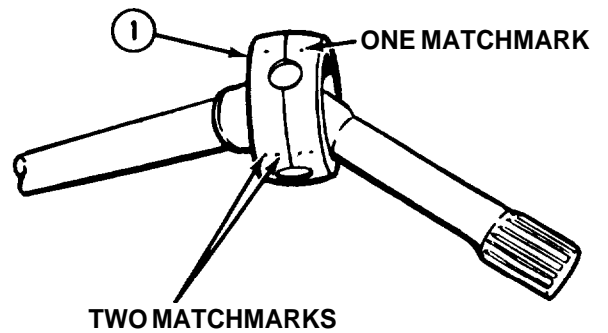

Axles No. 1 and No. 2 Maintenance Instructions (Cont)

9-2. AXLE SHAFT ASSEMBLY REMOVAL/REPAIR/INSTALLATION (CONT).

- (2) Remove eight screws (2) from cage ring halves (1).
- (3) Remove cage ring halves (1) from shafts (3 and 4).
- (4) Assemble cage ring halves (1) with eight screws (2). Tighten screws to 30 lb-ft (41 N•m).
- (5) Measure inside diameter of cage ring halves (1) and outside diameter of yokes on shafts (3 and 4). If difference is more than 0.200 in. (5.08 mm), replace cage ring halves (1) and shafts (3 and 4).
- (6) Remove eight screws (2) from cage ring halves (1).

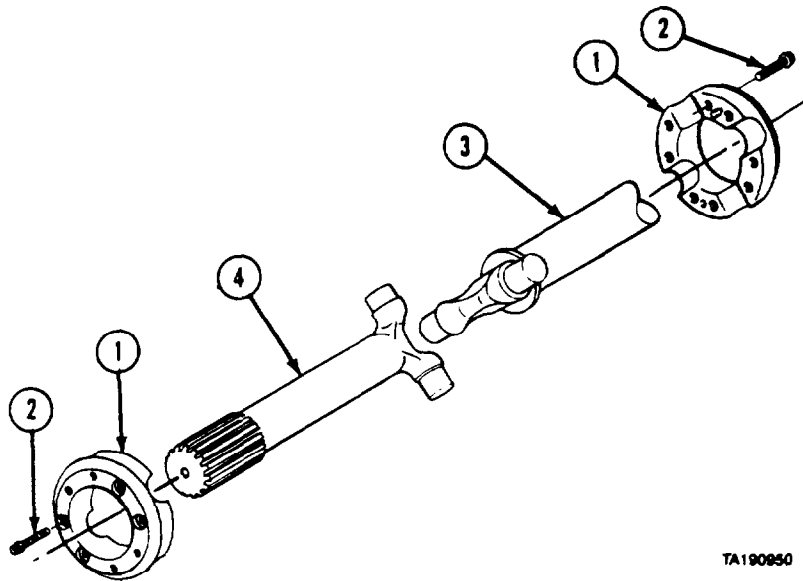

TA190850

c. Cleaning/Inspection.

WARNING

Adhesives, solvents, and sealing compounds can burn easily, can give off harmful vapors, and are harmful to skin and clothing. To avoid injury or death, keep away from open fire and use in well-ventilated area. If adhesive, solvent, or sealing compound gets on skin or clothing, wash immediately with soap and water.

- (1) Clean parts in dry cleaning solvent.
- (2) Inspect parts for damage.
- (3) Replace damaged parts.

d. Assembly.

- (1) Apply light film of grease to four trunnions (1) and two halves of cage ring (2).
- (2) Aline matchmarks and install two halves of cage ring (2) on two shafts (3 and 4).
- (3) Install eight screws (5). Do not tighten.
- (4) Move two shafts (3 and 4) to check for free side-to-side movement inside cage ring (2).
- (5) Tighten eight screws (5) to 95 lb-ft (129 N•m).

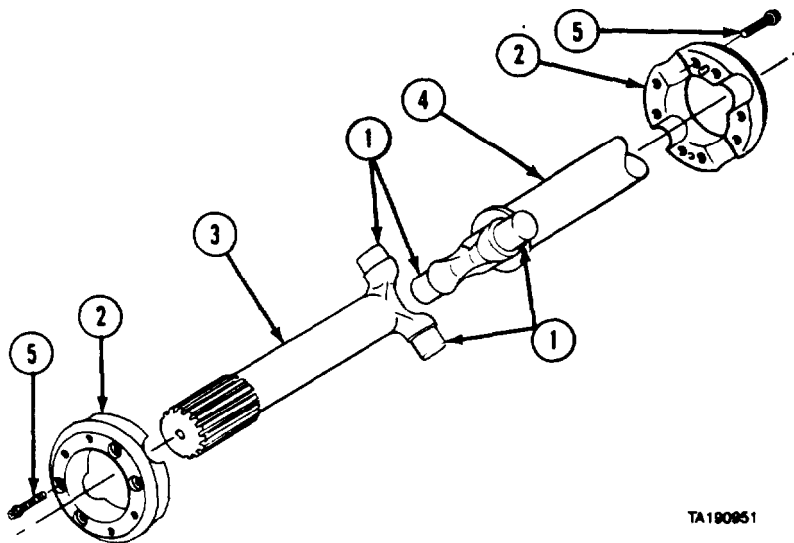

TA190851

Axles No. 1 and No. 2 Maintenance Instructions (Cont)

e. Installation.

- (1) Turn ball socket (1) to straight ahead position.
- (2) Apply thin coat of oil to polished surfaces of axle shaft assembly (2).
- (3) Pack cage ring (3) with grease.

CAUTION

Use care when installing axle shaft. Axle housing oil seal could be damaged.

- (4) Install axle shaft assembly (2) in ball socket (1) long end first.
- (5) Fill ball socket (1) and cage ring (3) with 7.5 to 8.5 lbs (3.40 to 3.86 kg) of grease.

WARNING

Adhesives, solvents, and sealing compounds can burn easily, can give off harmful vapors, and are harmful to skin and clothing. To avoid injury or death, keep away from open tire and use in well-ventilated area. If adhesive, solvent, or sealing compound gets on skin or clothing, wash immediately with soap and water.

- (6) Apply thin coat of silicone adhesive-sealant to both sides of brake spider (4) and axle skein (5).

NOTE

If pin was removed, perform step (6.1). If pin was not removed, proceed to step (7).

- (6.1) Install pin (5.1) in ball socket (1).
- (7) Aline matchmarks on brake spider (4) with marks on axle skein (5).
- (8) Install brake spider (4) and axle skein (5) over axle shaft assembly (2).
- (9) Aline matchmarks on brake spider (4) and axle skein (5) with matchmarks on ball socket (1).

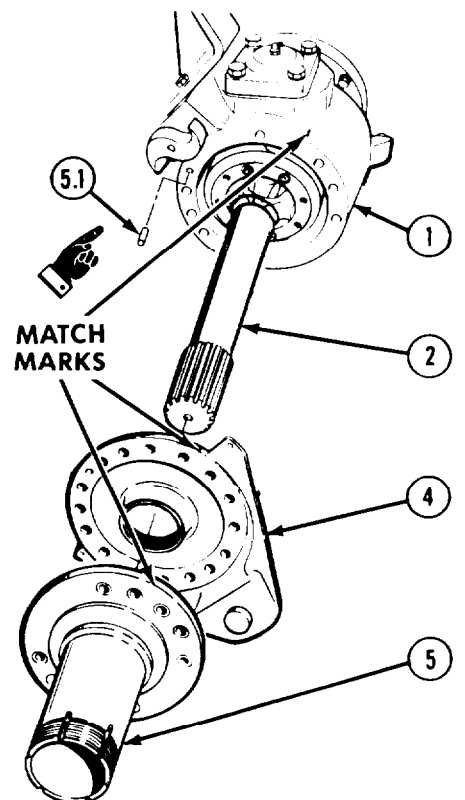
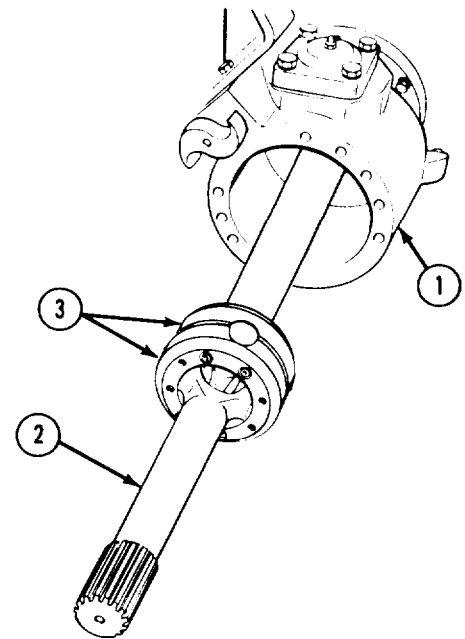

Axles No. 1 and No. 2 Maintenance Instructions (Cont)

9-2. AXLE SHAFT ASSEMBLY REMOVAL/REPAIR/INSTALLATION (CONT).

- (10) Apply silicone adhesive-sealant to underside of heads of 10 screws (6).
- (11) Install 10 screws (6). Tighten screws to 185 to 190 lb-ft (251 to 257 N•m).
- (12) Apply thin coat of grease to bearing and seal surfaces of axle skein (6).

f. Follow-on Maintenance.

- (1) Install front brakeshoes (TM 9-2320-279-20).
- (2) Fill axle (LO 9-2320-279-12).

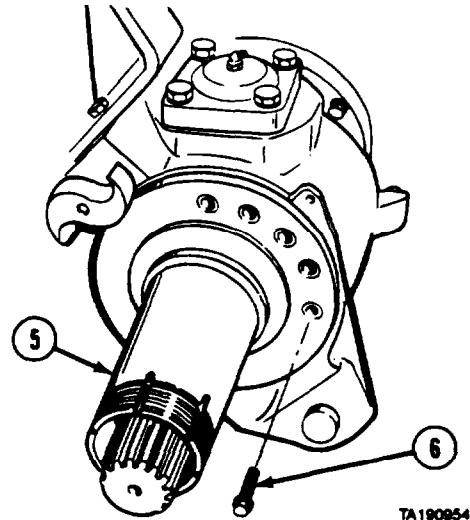

END OF TASK

9-3. AXLE NO. 1 REMOVAL/INSTALLATION.

This task covers:

- a. Removal
- b. Installation
- c. Follow-on Maintenance

INITIAL SETUP

Models

All

Test Equipment

None

Special Tools

None

Supplies

Preventive, rust, Item 53, Appendix C
oil, lubricating, Item 46, Appendix C

Personnel Required

MOS 63W, Wheel vehicle repairer (2)

References

None

Equipment Condition

TM or Para

TM 9-2320-279-20

Para 9-14

TM 9-2320-279-20

Para 14-4

Condition Description

Propeller shaft removed from No. 1 axle.

Ball and bushing removed from No. 1 axle.

Shocks removed from No. 1 axle.

Lateral torque rod removed (front only).

Special Environmental Conditions

None

General Safety Instructions

Wheels chocked.

Level of Maintenance

Direct Support

Axles No. 1 and No. 2 Maintenance Instructions (Cont)

a. Removal.

- (1) Remove three screws (1), washers (2), nuts (3), lockwashers (4), clamps (5), and two air lines (6) from three brackets (7). Move air lines out of way.
- (2) Soldier A and Soldier B secure axle to suitable lifting device.

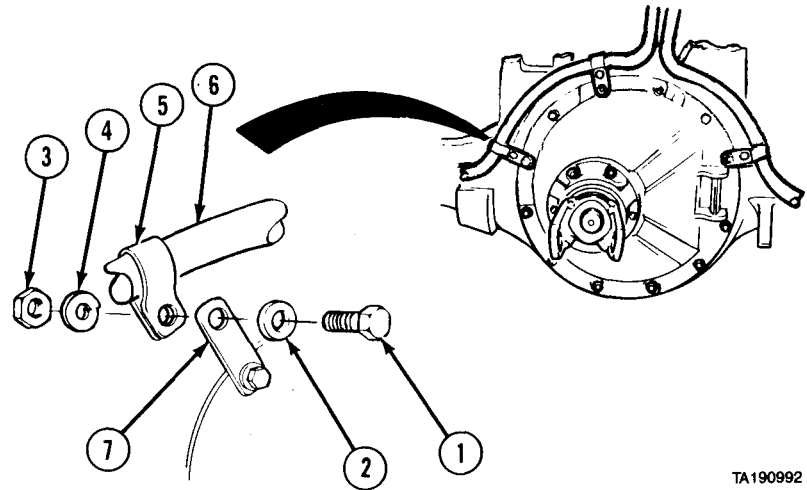

TA190992

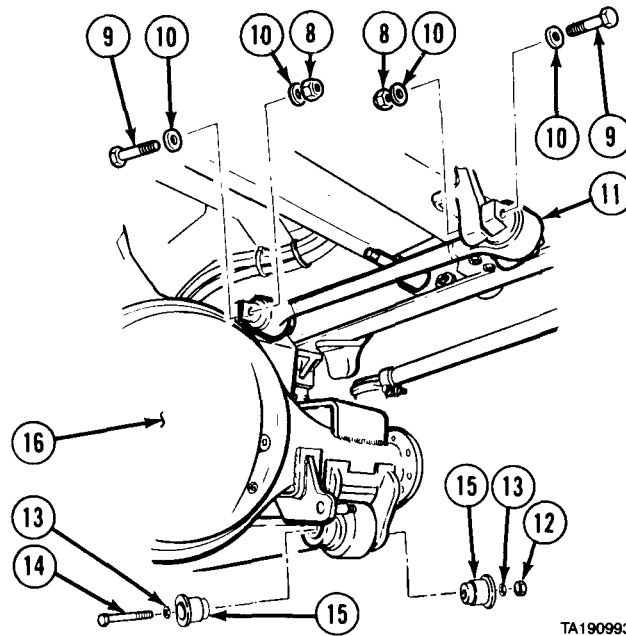

TA190993

- (3) Remove four locknuts (8), four screws (9), eight washers (10), and torque rod (11).

NOTE

Screw on right side can only be removed with inner beam end adapter.

- (4) Remove locknut (12), two washers (13), screw (14), and two beam end adapters (15) on right and left sides.
- (5) Soldier A and Soldier B remove axle (16).

Axles No. 1 and No. 2 Maintenance Instructions (Cont)

9-3. AXLE NO. 1 REMOVAL/INSTALLATION (CONT).

b. Installation.

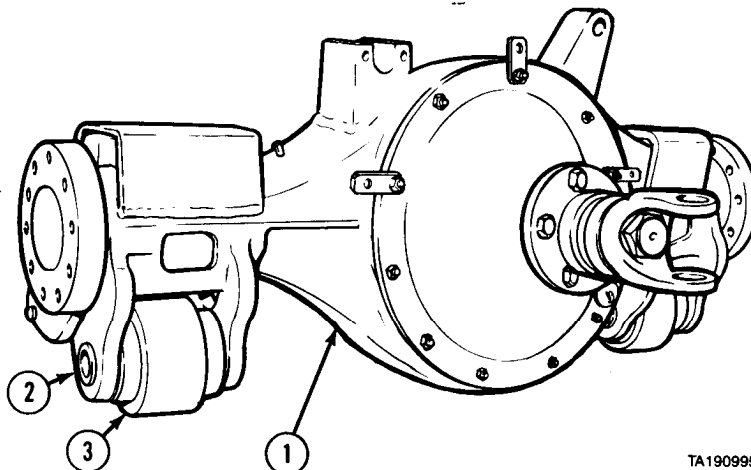

TA190995

- (1) Soldier A and Soldier B position axle (1) on suitable lifting device.
- (2) Soldier A and Soldier B install axle (1) and align holes in each axle beam hanger bracket (2) with holes in each equalizer beam (3).

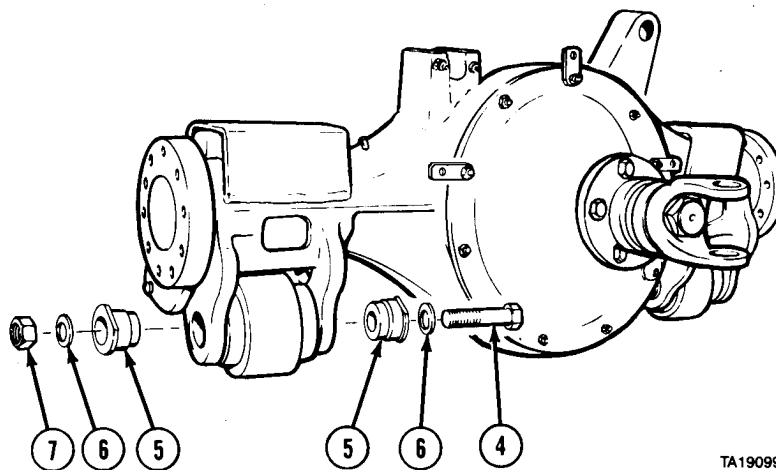

TA190996

NOTE

Screw on right side can only be installed with inner beam end adapter.

- (3) Lubricate threads of two screws (4) with oil and four beam end adapters (5) with rust preventive.
- (4) Install four beam end adapters (5), washers (6), two screws (4), and two locknuts (7) loosely.

Axles No. 1 and No. 2 Maintenance Instructions (Cont)

- (5) Lubricate threads of four screws (8) with oil. Install torque rod (9), four screws, eight washers (10), and four locknuts (11). Tighten locknuts to 95 to 130 lb-ft (129 to 176 N·m).

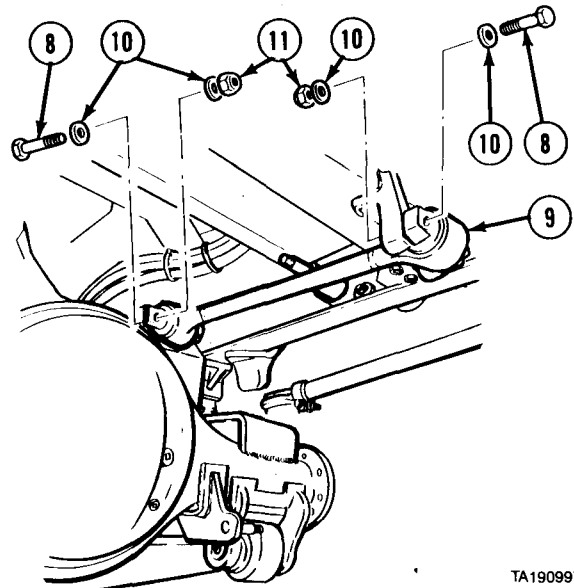

TA190997

- (6) Tighten two screws (4) and locknuts (7) to 210 to 240 lb-ft (285 to 325 N·m).
- (7) Remove lifting device from axle (1).

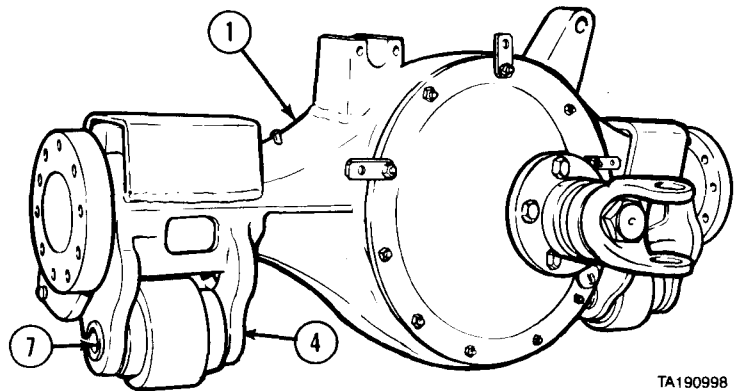

TA190998

- (8) Install two air lines (12), three clamps (13), screws (14), washers (15), lockwashers (16), and nuts (17) to three brackets (18).

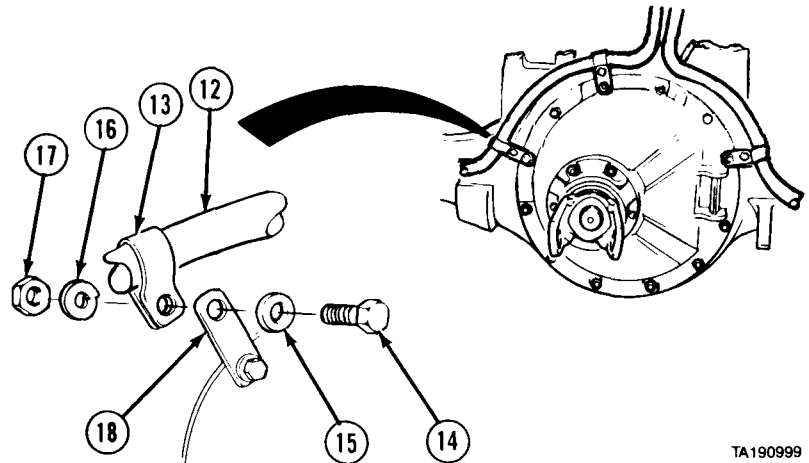

TA190999

c. Follow-on Maintenance.

- (1) Install shock absorbers (TM 9-2320-279-20).
- (2) Install lateral torque rod (para 14-4).
- (3) Install ball and bushing (para 9-14).
- (4) Install propeller shaft (TM 9-2320-279-20).
- (5) Check and fill oil in No. 1 axle (LO 9-2320-279-12).
- (6) Adjust steering toe-in (para 12-9).
- (7) Aline front axles (para 12-10).

END OF TASK

Axles No. 1 and No. 2 Maintenance Instructions (Cont)

9-4. AXLE NO. 2 REMOVAL/INSTALLATION.

This task covers:

- a. Removal
- b. Installation
- c. Follow-on Maintenance

INITIAL SETUP

Models

All

Test Equipment

None

Special Tools

None

Supplies

Preventive, rust, Item 53, Appendix C
 Oil, lubricating, Item 46, Appendix C
 Tags, identification, Item 60, Appendix C

Personnel Required

MOS 63W, Wheel vehicle repairer (2)

References

None

Equipment Condition

TM or Para

Condition Description

- | | |
|------------------|---|
| TM 9-2320-279-20 | Propeller shaft removed from No. 2 axle. |
| TM 9-2320-279-20 | Shocks removed from No. 2 axle. |
| Para 14-4 | Second lateral torque rod removed. |
| Para 9-14 | Ball and bushing removed from No. 2 axle. |

Special Environmental Conditions

None

General Safety Instructions

Wheels chocked.

Level of Maintenance

Direct Support

a. Removal.

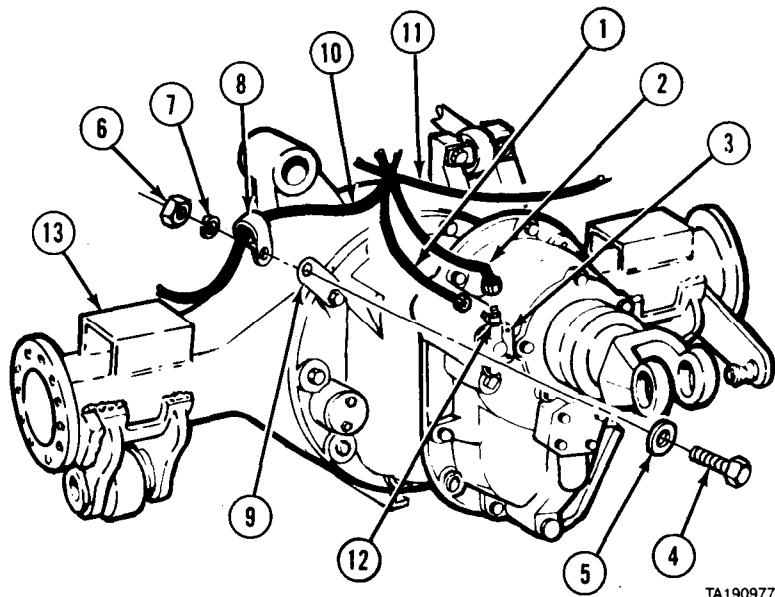
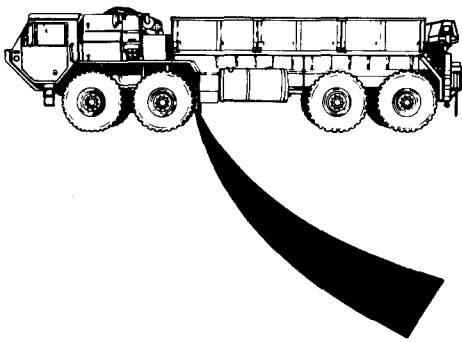

TA190977

Axles No. 1 and No. 2 Maintenance Instructions (Cont)

NOTE

Tag and mark air lines before disconnecting.

- (1) Disconnect two air lines (1 and 2) from lockout air chamber (3).
- (2) Remove three screws (4), washers (5), nuts (6), lockwashers (7), and clamps (8) from three brackets (9). Move two hoses (10 and 11) aside.
- (3) Remove fitting (12) from lockout air chamber (3).
- (4) Position suitable lifting device and secure to axle (13).

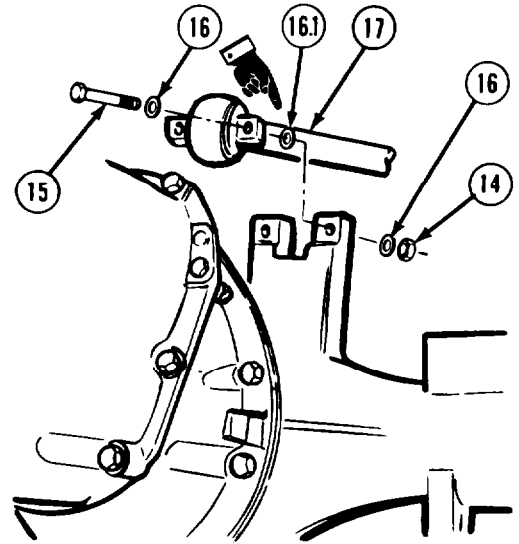

NOTE

- Do not disconnect frame end of torque rod.
 - Some models of vehicles contain washers between torque rod and axle. Perform step (5.1) for these models.
- (5) Remove two locknuts (14), screws (15), and four washers (16), and disconnect axle end of torque rod (17).
 - (5.1) Remove two locknuts (14), screws (15), four washers (16), two washers (16.1), and disconnect axle end of torque rod (17).

NOTE

Screw on left side can only be removed with inner beam end adapter.

- (6) Remove two locknuts (18), four washers (19), two screws (20), and four beam end adapters (21) from two equalizer beams (22).
- (7) Soldier A and Soldier B remove axle (13).

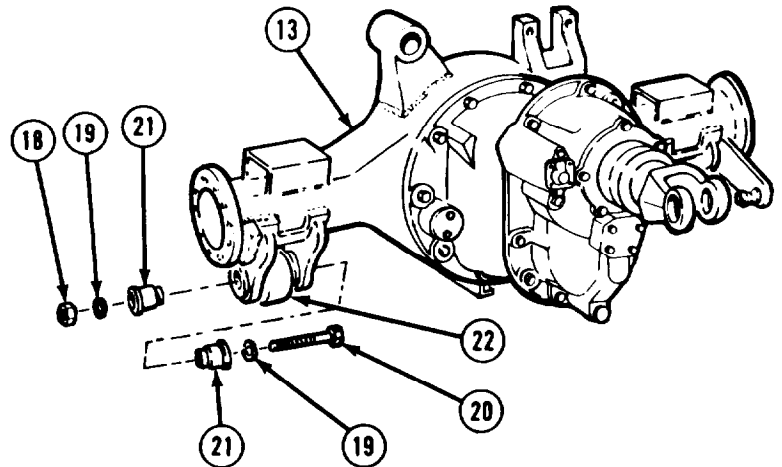

Axles No. 1 and No. 2 Maintenance Instructions (Cont)

9-4. AXLE NO. 2 REMOVAL/INSTALLATION (CONT).

b. Installation.

- (1) Secure axle (1) to suitable lifting device.
- (2) Soldier A and Soldier B install axle (1) and align holes in two axle beam hanger brackets (2) with holes in two equalizer beams (3).

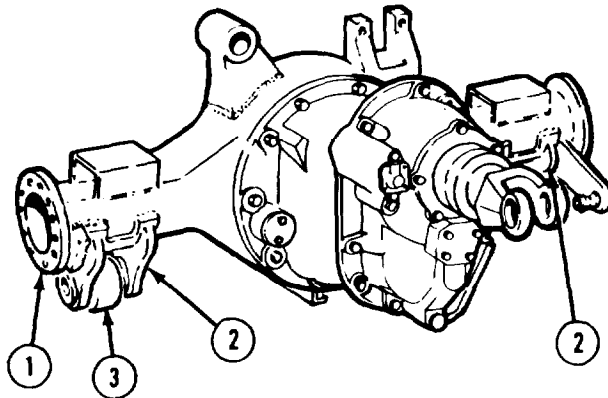

- (3) Lubricate threads of two screws (4) with oil and four beam end adapters (5) with rust preventive.

NOTE

Screw on left side can only be installed with inner beam end adapter.

- (4) Install two screws (4), four washers (5), four beam end adapters (6) and two nuts (7) loosely.

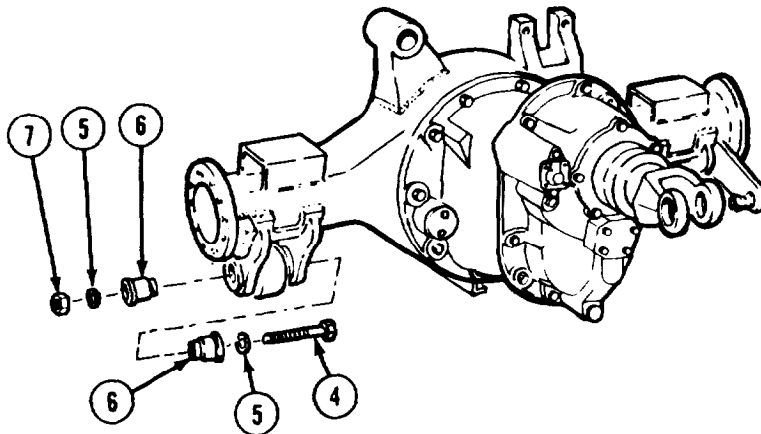

NOTE

Some models of vehicles require washers between torque rod and axle. Perform step (5.1) for these models.

- (5) Lower torque rod (8) onto axle (1). Lubricate two screws (9) with oil and install screws, four washers (10), and two locknuts (11).
- (5.1) Lower torque rod (8) onto axle (1) with two washers (8.1) positioned between torque rod and axle. Lubricate two screws (9) with oil and install screws, four washers (10), and two locknuts (11).
- (6) Tighten two locknuts (11) to 95 to 130 lb-ft (129 to 176 N•m).

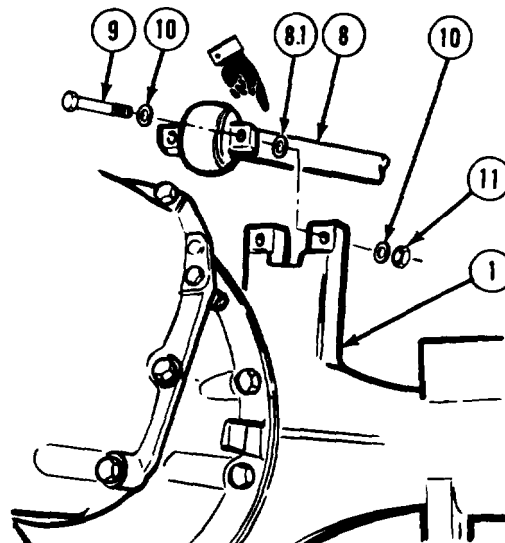

Axles No. 1 and No. 2 Maintenance Instructions (Cont)

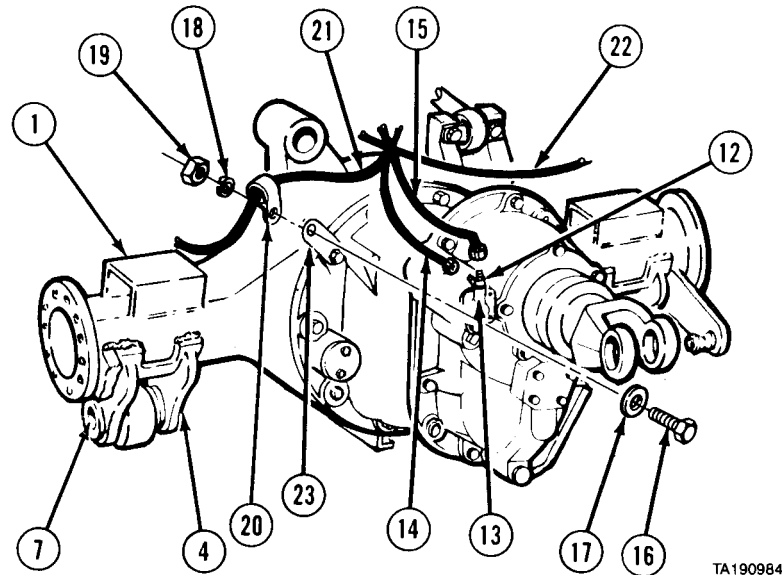

- (7) Tighten two screws (4) and nuts (7) to 210 to 240 lb-ft (285 to 325 N·m).
- (8) Remove suitable lifting device from axle (1).
- (9) Install fitting (12) to lockout air chamber (13).
- (10) Install two air lines (14 and 15) to lockout air chamber (13).
- (11) Install three screws (16), washers (17), lockwashers (18), nuts (19), clamps (20), and two hoses (21 and 22) to three brackets (23).

c. Follow-on Maintenance.

- (1) Install second lateral torque rod (para 14-4).
- (2) Install shock absorbers (TM 9-2320-279-20).
- (3) Install ball and bushing (para 9-14).
- (4) Install propeller shaft (TM 9-2320-279-20).
- (5) Check and fill No. 2 axle (LO 9-2320-279-12).
- (6) Adjust steering toe-in (para 12-9).
- (7) Aline front axle (para 12-10).

END OF TASK

Axles No. 1 and No. 2 Maintenance Instructions (Cont)

9-5. AXLE HOUSING COVER ASSEMBLY, AXLE NO. 2 REMOVAL/REPAIR/INSTALLATION.	
This task covers:	
a. Removal	d. Assembly
b. Disassembly	e. Installation
c. Cleaning/Inspection	f. Follow-on Maintenance
INITIAL SETUP	
<i>Models</i>	<i>References</i>
All	None
<i>Test Equipment</i>	<i>Equipment Condition</i>
None	<i>TM or Para</i> <i>Condition Description</i>
<i>Special Tools</i>	LO 9-2320-279-12 Axle lubrication drained.
None	Para 9-6 Yoke and oil seal removed.
<i>Supplies</i>	<i>Special Environmental Conditions</i>
Grease, automotive and artillery, GAA, Item 34, Appendix C	None
Solvent, dry cleaning, Item 57, Appendix C	<i>General Safety Instructions</i>
Adhesive-sealant, silicone, Item 6, Appendix C	None
Oil, lubricating, gear, Item 47, Appendix C	<i>Level of Maintenance</i>
<i>Personnel Required</i>	Direct Support
MOS 63W, Wheel vehicle repairer	

Axles No. 1 and No. 2 Maintenance Instructions (Cont)

a. Removal.

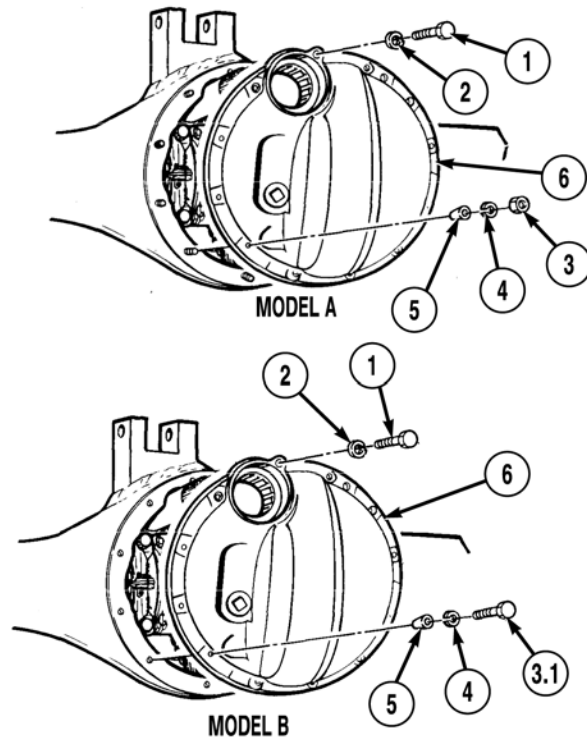
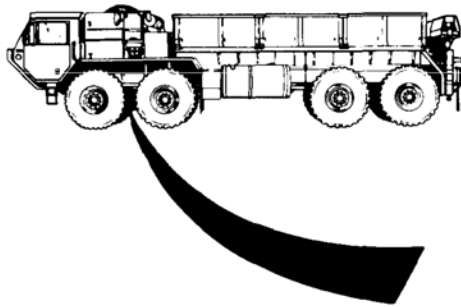

- (1) Remove screw (1) and lockwasher (2).

NOTE

- Perform step (2) for Non-A2 and A2R1 model vehicles.
 - Perform step (2.1) for A2 and A2R1 model vehicles.
- (2) Remove 11 nuts (3), lockwashers (4), and four tapered locks (5).
 - (2.1) Remove 11 screws (3.1), lockwashers (4) and four tapered locks (5).
 - (3) Remove cover (6).

Axles No. 1 and No. 2 Maintenance Instructions (Cont)

- (4) Remove bearing sleeve (7).

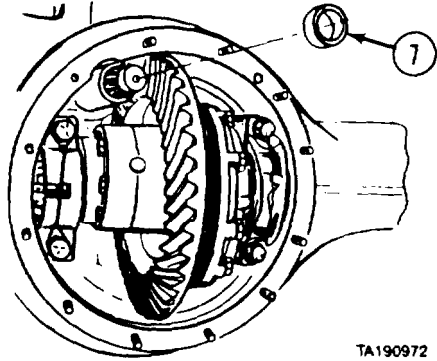

b. Disassembly.

- (1) Remove pipe plug (1) and magnetic plug (2) from cover (3).
- (2) Remove retaining ring (4).
- (3) Remove roller bearing (5).

c. Cleaning/Inspection.

WARNING

Adhesives, solvents, and sealing compounds can burn easily, can give off harmful vapors, and are harmful to skin and clothing. To avoid injury or death, keep away from open fire and use in well-ventilated area. If adhesive, solvent, or sealing compound gets on skin or clothing, wash immediately with soap and water.

- (1) Clean all metal parts with dry cleaning solvent.

WARNING

Compressed air used for cleaning purposes will not exceed 30 psi (207 kPa). Use only with effective chip guarding and personal protective equipment, goggles, shield, and gloves.

- (2) Dry metal parts, except bearings, with compressed air.
- (3) Allow bearings to air dry.
- (4) Inspect metal parts for breaks, cracks, and sharp edges.
- (5) Inspect machined parts for nicks and burrs.
- (6) Inspect bearings for loose rollers and cracked or broken races.
- (7) Coat bearing with lubricating oil.
- (8) Inspect dowel pins and mounting studs for cracks, breaks, and damaged threads.
- (9) Replace all damaged parts.

d. Assembly.

- (1) Pack roller bearing (5) with grease and install in cover (3).
- (2) Install retaining ring (4).
- (3) Install magnetic plug (2) and pipe plug (1).

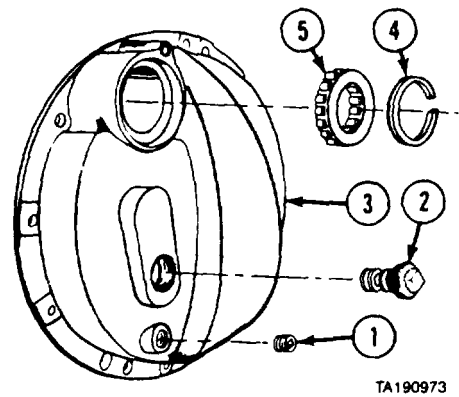

Axles No. 1 and No. 2 Maintenance Instructions (Cont)

9-5. AXLE HOUSING COVER ASSEMBLY, AXLE NO. 2 REMOVAL/REPAIR/INSTALLATION (CONT).

e. Installation.

- (1) Install bearing sleeve (1).

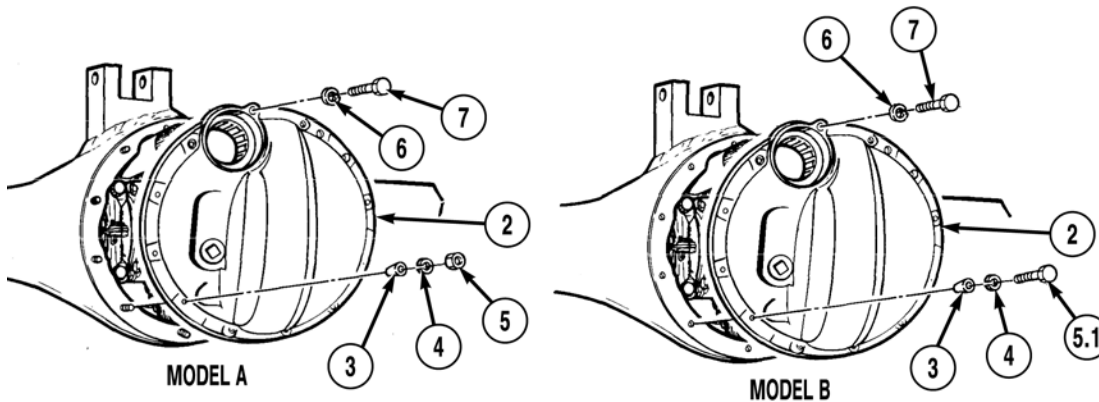
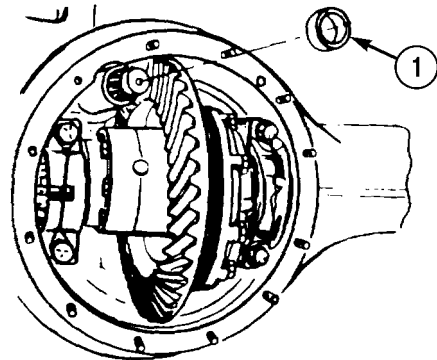

WARNING

Adhesives, solvents, and sealing compounds can burn easily, can give off harmful vapors, and are harmful to skin and clothing. To avoid injury or death, keep away from open fire and use in well-ventilated area. If adhesive, solvent, or sealing compound gets on skin or clothing, wash immediately with soap and water.

NOTE

- Perform step (2) for Non-A2 and A2R1 model vehicles.
 - Perform step (2.1) for A2 and A2R1 model vehicles.
- (2) Apply silicone adhesive-sealant and install cover (2) with four tapered locks (3), 11 lockwashers (4), and nuts (5). Tighten nuts to 55 lb-ft (75 N•m).
 - (2.1) Apply silicone adhesive-sealant and install cover (2) with four tapered locks (3), 11 lockwashers (4), and screws (5.1). Tighten screws to 55 lb-ft (75 N•m).
 - (3) Install lockwasher (6) and screw (7). Tighten screw to 40 lb-ft (54 N•m).

f. Follow-on Maintenance.

- (1) Install yoke and oil seal (para 9-6).
- (2) Fill axle (LO 9-2320-279-12).

Axles No. 1 and No. 2 Maintenance Instructions (Cont)

9-6. AXLES NO. 1 AND NO. 2 YOKE AND OIL SEAL REMOVAL/INSTALLATION.

This task covers:

- a. Removal
- b. Cleaning/Inspection
- c. Installation
- d. Follow-on Maintenance

INITIAL SETUP

Models

All

Test Equipment

None

Special Tools

- Socket, 2 1/4-in. 2BF878
- Socket, 2 7/8-in. 2BF707

Supplies

- Oil, lubricating, Item 47, Appendix C
- Solvent, dry cleaning, Item 57, Appendix C

Personnel Required

MOS 63W, Wheel vehicle repairer (2)

References

None

Equipment Condition

TM or Para *Condition Description*
 TM 9-2320-279-20 Propeller shaft removed.

Special Environmental Conditions

None

General Safety Instructions

None

Level of Maintenance

Direct Support

a. Removal.

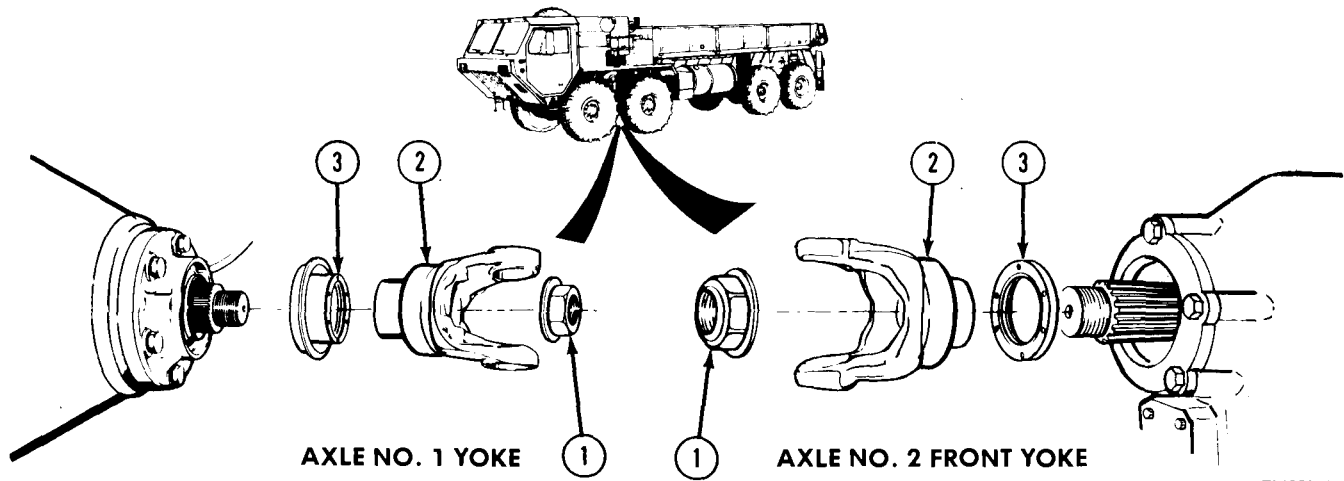

TA190941

NOTE

Differential must be locked before yoke nut can be loosened.

- (1) Set TRACTION CONTROL lever to 8 × 8 DRIVE (TM 9-2320-279-10).
- (2) Soldier A and Soldier B remove flanged nut (1) and yoke (2).
- (3) Remove oil seal (3).

Axles No. 1 and No. 2 Maintenance Instructions (Cont)

9-6. AXLES NO. 1 AND NO. 2 YOKE AND OIL SEAL REMOVAL/INSTALLATION (CONT).

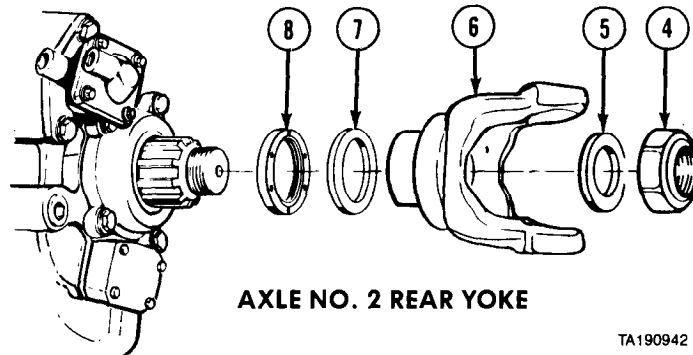

- (4) Soldier A and Soldier B remove locknut (4), washer (5), and yoke (6).
- (5) Remove spacer (7) and oil seal (8).

b. Cleaning/Inspection.

WARNING

Adhesives, solvents, and sealing compounds can burn easily, can give off harmful vapors, and are harmful to skin and clothing. To avoid injury or death, keep away from open fire and use in well-ventilated area. If adhesive, solvent, or sealing compound gets on skin or clothing, wash immediately with soap and water.

- (1) Clean yoke with dry cleaning solvent.
- (2) Check yoke for damage. Replace if damaged.
- (3) Apply light film of oil on yoke.

c. Installation.

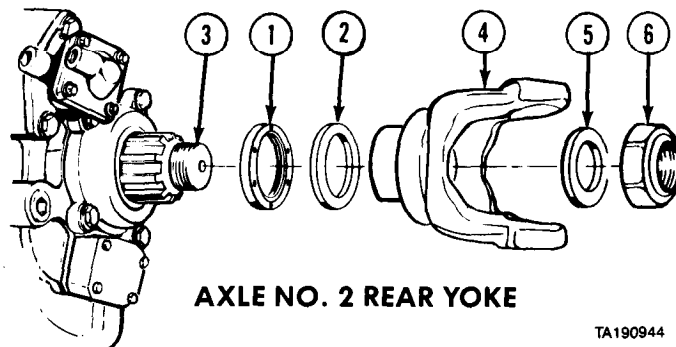

- (1) Lubricate oil seal (1) with oil. Install oil seal and spacer (2) on shaft (3).

NOTE

To tighten yoke nuts, use torque multiplier and 250 lb-ft capacity ratchet end torque wrench.

- (2) Install yoke (4) with washer (5) and locknut (6). Soldier A and Soldier B tighten nut to 840 to 1020 lb-ft (1130 to 1383 N·m).

Axles No. 7 and No. 2 Maintenance Instructions (Cont)

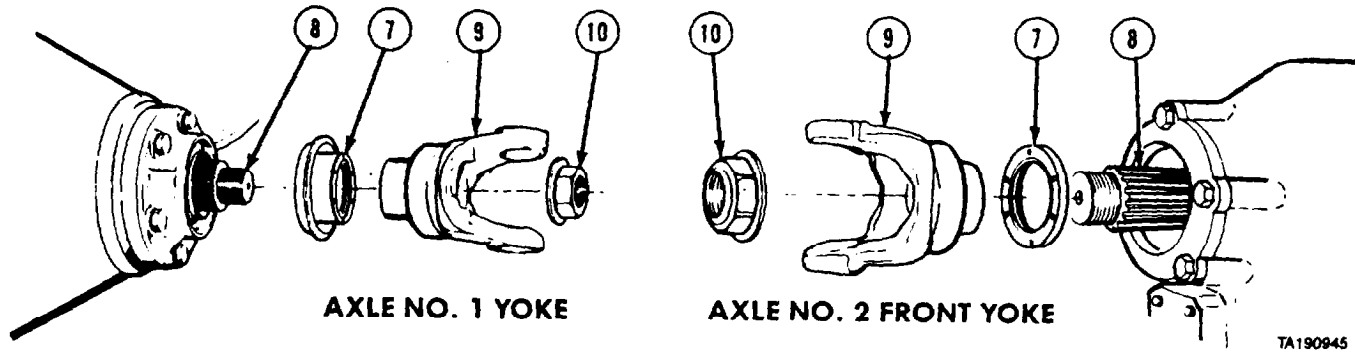

- (3) Lubricate oil seal (7) with oil. Install oil seal on shaft (8).
- (4) Install yoke (9) with flanged nut (10). Soldier A and Soldier B tighten nut to 840 to 1020 lb-ft (1139 to 1383 N•m).
- (5) Set TRACTION CONTROL lever to OFF position (TM 9-2320-279-10).

d. Follow-on Maintenance. Install propeller shaft (TM 9-2320-279-20).

END OF TASK

Section III. DIFFERENTIAL CARRIERS

9-7. DIFFERENTIAL CARRIER, AXLE NO. 1 REMOVAL/INSTALLATION.	
This task covers:	
a. Removal	c. Installation
b. Cleaning/Inspection	d. Follow-on Maintenance
INITIAL SETUP	
<i>Models</i>	<i>References</i>
All	None
<i>Test Equipment</i>	<i>Equipment Condition</i>
None	<i>TM or Para</i> <i>Condition Description</i>
<i>Special Tools</i>	Para 9-3 Axle No. 1 removed.
None	<i>Special Environmental Conditions</i>
<i>Supplies</i>	None
Solvent, dry cleaning, Item 57, Appendix C	<i>General Safety Instructions</i>
Adhesive-sealant, silicone, Item 6, Appendix C	None
<i>Personnel Required</i>	<i>Level of Maintenance</i>
MOS 63W, Wheel vehicle repairer (2)	Direct Support

9-7. DIFFERENTIAL CARRIER, AXLE NO. 1 REMOVAL/INSTALLATION (CONT).

a. Removal.

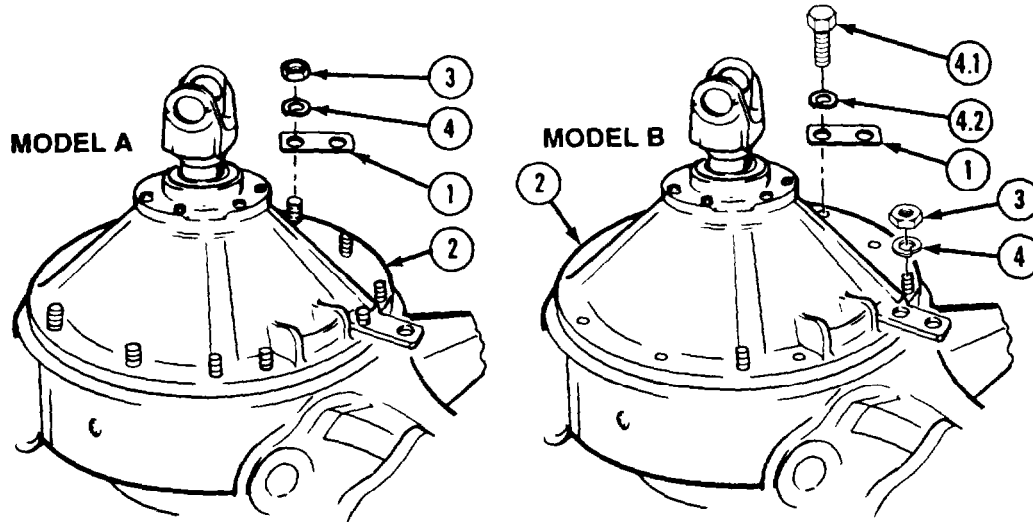

NOTE

- There are two models of axle housings: Model A and Model B. The differential carrier is mounted on Model A housing by studs, lockwashers, and nuts. The differential carrier is mounted on Model B housing by a combination of studs, lockwashers, and nuts, and screws and lockwashers.
- Do steps (1), (2), and (3) through (5) for Model A housing.
- Do steps (1) and (2.1) through (5) for Model B housing.

- (1) Mark location of air line brackets (1) on differential carrier (2).
- (2) Remove 12 nuts (3), lockwashers (4), and three air line brackets (1) from differential carrier (2).
- (2.1) Remove four nuts (3) and lockwashers (4) from differential carrier (2).
- (2.2) Tag and mark placement of 2 1/4 inch screws and 1 3/4 inch screws during removal.
- (2.3) Remove eight screws (4.1), lockwashers (4.2), and three air line brackets (1).

WARNING

Keep out from under differential carrier. Serious injury may result if differential carrier falls from lifting device.

CAUTION

Do not strike differential carrier to loosen if stuck. Tap around edge of flange to avoid damage.

- (3) Attach lifting device to differential carrier (2).
- (4) Soldier A removes differential carrier (2) while Soldier B operates lifting device.
- (5) Mount differential carrier (2) on stand. Remove lifting device.

Axles No. 1 and No. 2 Maintenance Instructions (Cont)

b. Cleaning/Inspection.

- (1) Scrape dirt and old sealant from mounting surface (1) on axle housing (2).

WARNING

Adhesives, solvents, and sealing compounds can burn easily, can give off harmful vapors, and are harmful to skin and clothing. To avoid injury or death, keep away from open fire and use in well-ventilated area. If adhesive, solvent, or sealing compound gets on skin or clothing, wash immediately with soap and water.

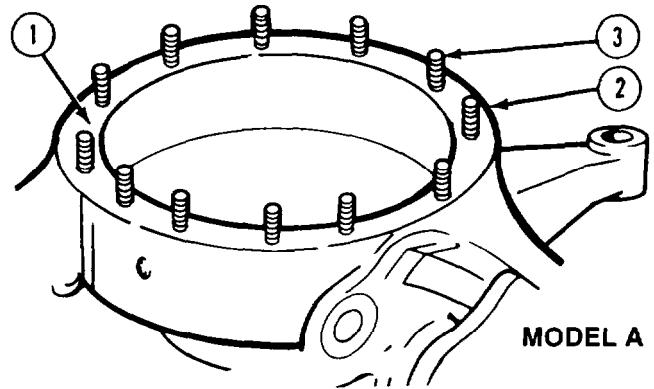

- (2) Use drycleaning solvent to clean axle housing (2).
- (3) Use clean cloth to wipe dry.
- (4) Inspect mounting studs (3) for cracks, breaks, and damaged threads. Replace if damaged.
- (5) Inspect axle housing (2) for cracks or damage. Replace if damaged.

c. Installation.

WARNING

Keep out from under differential carrier. Serious injury may result if differential carrier falls from lifting device.

- (1) Attach suitable lifting device to differential carrier (1).
- (2) Soldier A removes differential carrier (1) from stand while Soldier B operates lifting device.
- (3) Apply silicone adhesive-sealant in pattern illustrated on mounting surface (2) of axle housing (3).

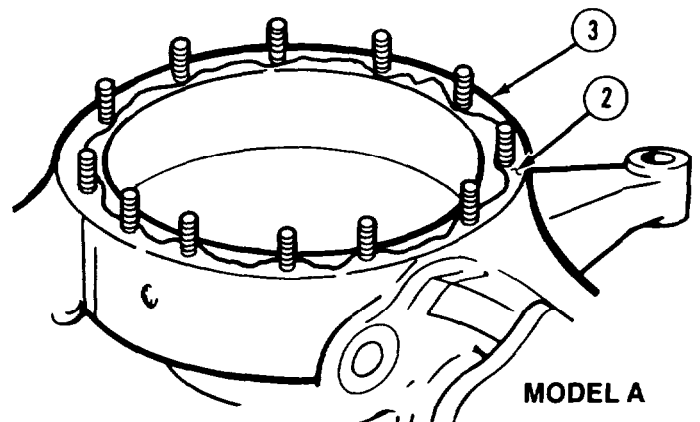
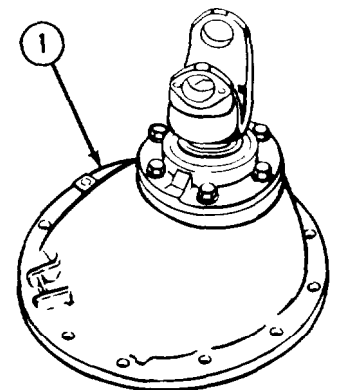

Axles No. 1 and No. 2 Maintenance Instructions (Cont)

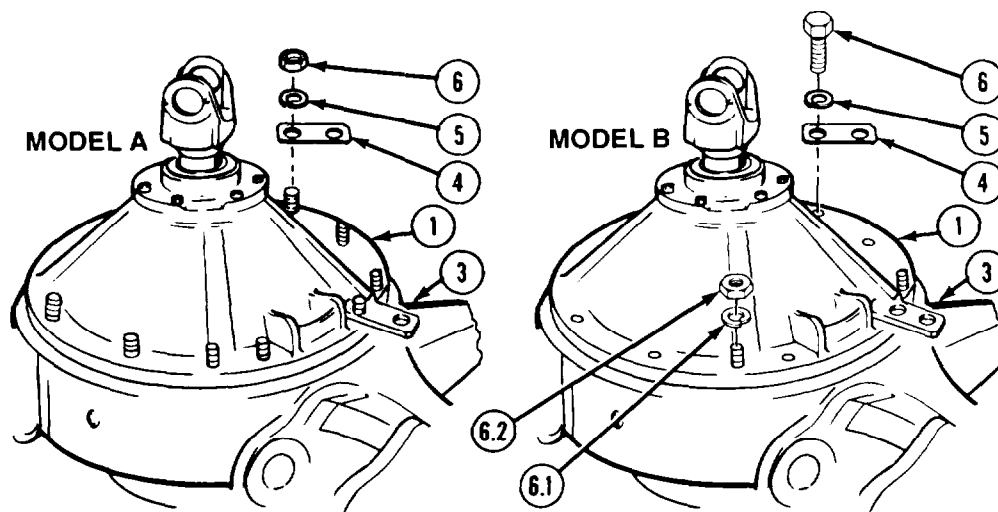

- (4) Install differential carrier (1) on axle housing (3).

NOTE

- There are two models of axle housings: Model A and Model B. The differential carrier is mounted on housing A by studs, lockwashers, and nuts. The differential carrier is mounted on housing B by a combination of studs, lockwashers, and nuts, and screws and lockwashers.
- Do steps (5) and (6) for housing A.
- Do steps (5.1), (5.2), and (6) for housing B.

- (5) Install three air line brackets (4), 12 lockwashers (5), and nuts (6). Tighten nuts to 180 lb-ft (244 N•m).

NOTE

Ensure 2 1/4 inch and 1 3/4 inch screws are positioned as tagged and marked during removal.

- (5.1) Install three air line brackets (4), eight lockwashers (5), and screws (6).
 (5.2) Install four lockwashers (6.1) and nuts (6.2) on differential carrier. Tighten nuts to 180 lb-ft (244 N•m).
 (6) Remove lifting device from differential carrier (1).

d. Follow-on Maintenance.

- (1) Install No. 1 axle (para 9-3).
 (2) Fill axle (LO 9-2320-279-12).

END OF TASK

Axles No. 1 and No. 2 Maintenances Instructions (Cont)

9-8. DIFFERENTIAL CARRIER COVER, AXLE NO. 2 REMOVAL/INSTALLATION.

This task covers:

- a. Removal
- b. Installation
- c. Follow-on Maintenance

INITIAL SETUP

Models
All

Test Equipment
Indicator, dial J7872

Special Tools
Socket, 2 7/8-in. IM 923

Supplies
Solvent, drycleaning, Item 57, Appendix C
Adhesive-sealant, silicone, Item 6, Appendix C
Oil, lubricating, Item 46, Appendix C
Tags, identification, Item 60, Appendix C
Compound, sealing and thread locking, Item 25, Appendix C

Personnel Required
MOS 63W, Wheel vehicle repairer (2)

References
None

Equipment Condition

TM or Para	Condition	Description
LO 9-2320-279-12	Axle drained.	
TM 9-2320-279-20	Propeller shafts removed.	

Special Environmental Conditions
None

General Safety Instructions
None

Level of Maintenance
Direct Support

a. Removal

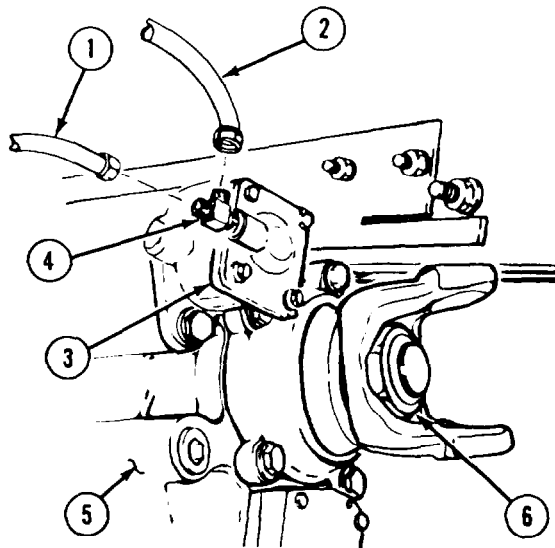
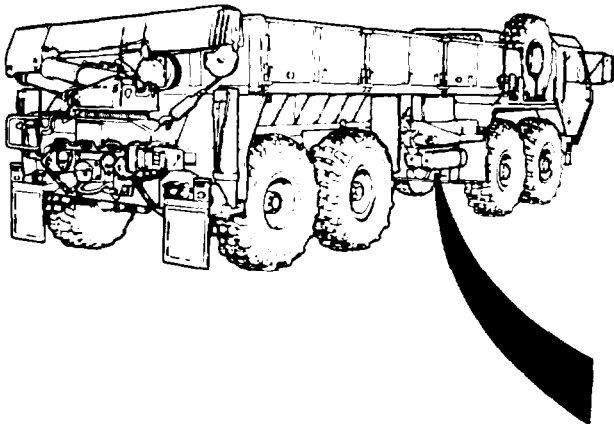

Axles No. 1 and No. 2 Maintenance Instructions (Cont)

NOTE

Tag and mark air lines before disconnecting.

- (1) Disconnect two air lines (1 and 2) from lockout air chamber (3).
- (2) Remove fitting (4) from lockout air chamber (3).
- (3) Support differential carrier cover (5) with suitable lifting device.
- (4) Loosen locknut (6).

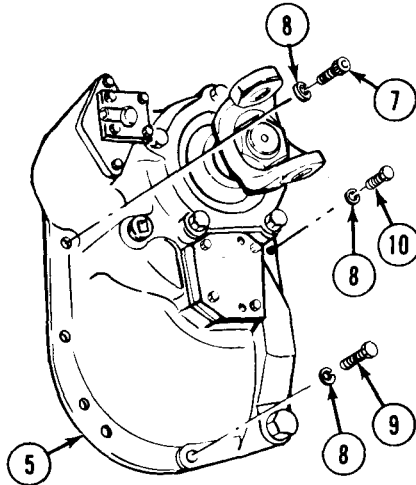

TA190917

- (5) Matchmark and remove screw (7) and lockwasher (8) from differential carrier cover (5).
- (6) Matchmark and remove screw (9) and lockwasher (8) from differential carrier cover (5).
- (7) Remove eight screws (10) and lockwashers (8) from differential carrier cover (5).

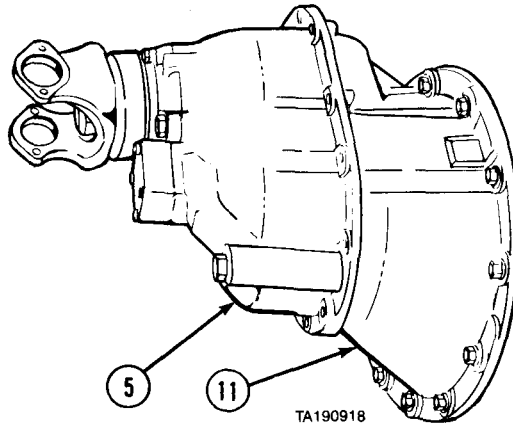

TA190918

- (8) Soldier A and Soldier B remove differential carrier cover (5) from differential carrier (11).

9-8. DIFFERENTIAL CARRIER COVER, AXLE NO. 2 REMOVAL/INSTALLATION (CONT).

b. Installation.

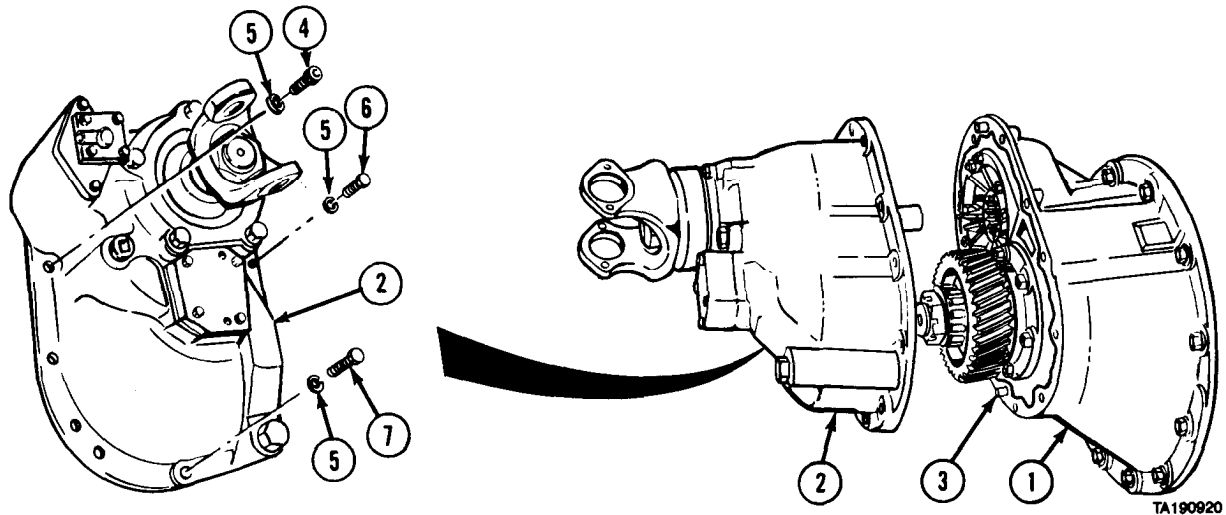

WARNING

Adhesives, solvents, and sealing compounds can burn easily, can give off harmful vapors, and are harmful to skin and clothing. To avoid injury or death, keep away from open fire and use in well-ventilated area. If adhesive, solvent, or sealing compound gets on skin or clothing, wash immediately with soap and water.

CAUTION

Dirt or old sealant can damage differential carrier parts. Do not let dirt or sealant fall into differential carrier.

- (1) Clean differential carrier (1) mounting surface with dry cleaning solvent. Use cloth to wipe surface dry.
- (2) Apply line of silicone adhesive-sealant on differential carrier (1) mounting surface.

CAUTION

Turn yoke to mesh gears and avoid damage to bearing.

- (3) Soldier A and Soldier B align differential carrier cover (2) on two dowel pins (3) and install cover on differential carrier (1).
- (4) Coat threads of screw (4) with oil and install lockwasher (5) and screw in differential carrier cover (2). Tighten screws finger-tight.
- (5) Coat threads of eight screws (6) with oil and install lockwashers (5) and screws in differential carrier cover (2). Tighten screws finger-tight.
- (6) Coat threads of screw (7) with oil and install lockwasher (5) and screw in differential carrier cover (2). Tighten screw finger-tight.
- (7) Tighten screws (4, 6, and 7) evenly, then tighten to 110 to 125 lb-ft (149 to 170 N·m).

Axles No. 1 and No. 2 Maintenance Instructions (Cont)

NOTE

To tighten yoke nut, use torque multiplier and 250 lb-ft capacity ratchet end torque wrench.

- (8) Tighten locknut (8) to 840 to 1020 lb-ft (1 139 to 1 383 N•m).
- (9) Attach dial indicator to yoke (9).
- (10) Push yoke (9) in, then pry yoke away from bearing cover (10) and read amount of end play on dial indicator. Allowable end play is 0.003 to 0.007-in. (0.08 to 0.18 mm).
- (11) Remove dial indicator from yoke (9).

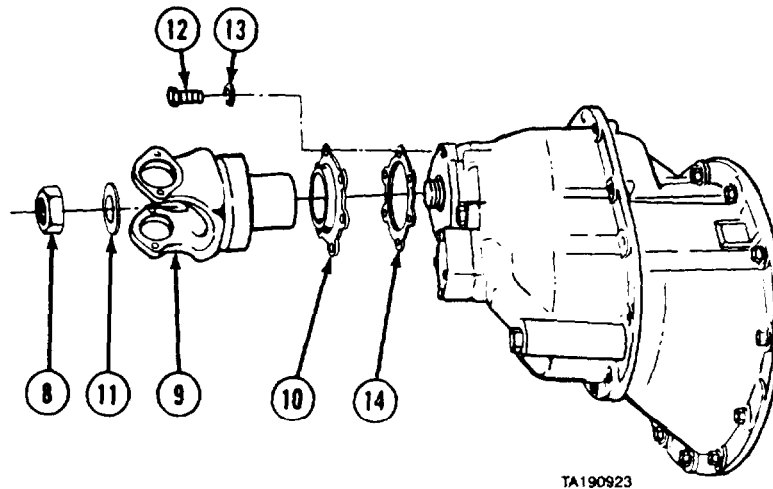
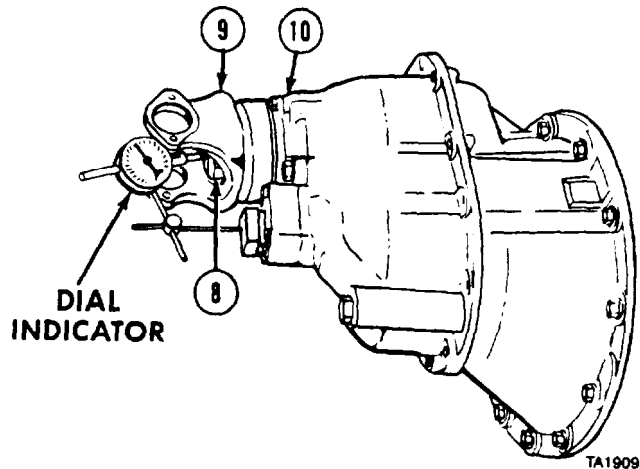

NOTE

- Steps (12) through (18) are performed only if end play adjustment is required.
- If measured end play is more than allowable amount, shims must be removed. If measured end play is less than allowable amount, shims must be added.

- (12) To correct amount of end play, remove locknut (8), washer (11), and yoke (9).
- (13) Remove five screws (12) and lockwasher (13) from bearing cover (10).
- (14) Remove bearing cover (10).
- (15) Add or remove shims (14) as necessary.
- (16) Install bearing cover (10) over shims (14).
- (17) Apply thread locking compound to five screws (12) and install lockwashers (13) and screws. Tighten screws to 75 to 86 lb-ft (102 to 115 N•m).
- (18) Install yoke (9), washer (11), and locknut (8). Using 2 7/8-in. socket, tighten nut to 840 to 1020 lb-ft (1 139 to 1 383 N-m).

Axles No. 1 and No. 2 Maintenance Instructions (Cont)

9-8. DIFFERENTIAL CARRIER COVER, AXLE NO. 2 REMOVAL/INSTALLATION (CONT).

- (19) Install fitting (15) in lockout air chamber (16).
- (20) Connect two air lines (17 and 18) to lockout air chamber (16).

c. Follow-on Maintenance.

- (1) Install propeller shafts (TM 9-2320-279-20).
- (2) Fill axle (LO 9-2320-279-12).

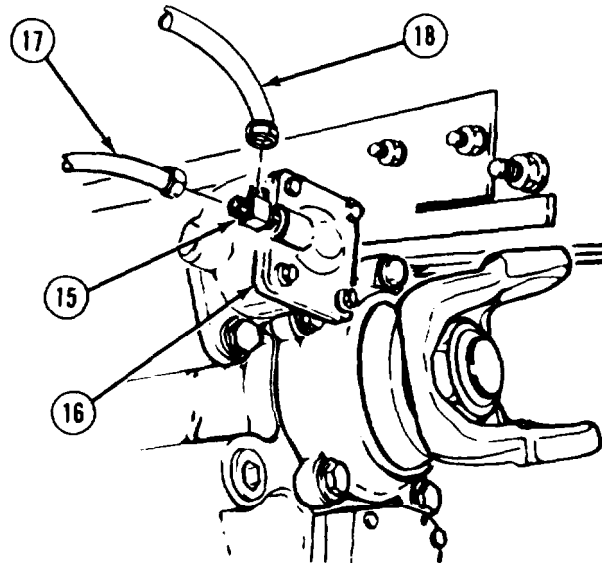

END OF TASK

9-9. DIFFERENTIAL CARRIER COVER, AXLE NO. 2 REPAIR.

This task covers:

- a. Disassembly
- b. Cleaning/Inspection
- c. Assembly
- d. Follow-on Maintenance

INITIAL SETUP

Models
All

Test Equipment
None

Special Tools
Socket, 2 7/8-in. IM 923

Supplies
Solvent, drycleaning, Item 57, Appendix C
Adhesive-sealant, silicone, Item 6, Appendix C
Oil, lubricating, gear, Item 43, Appendix C
Compound, sealing, Item 28, Appendix C

Personnel Required
MOS 63W, Wheel vehicle repairer

References
None

Equipment Condition
TM or Para *Condition Description*
Differential carrier cover on clean work surface.

Special Environmental Conditions
None

General Safety Instructions
None

Level of Maintenance
General Support

Axles No. 1 and No. 2 Maintenance Instructions (Cont)

a. Disassembly.

WARNING

Wear safety glasses to protect eyes from possible injury or blindness while removing retaining ring.

- (1) Remove retaining ring (1) and helical side gear (2) from input shaft (3).

NOTE

Thrust washer and D-washer may come off with helical side gear.

- (2) Remove thrust washer (4) and D-washer (5) from input shaft (3).
- (3) Remove two bushings (6) from helical side gear (2).

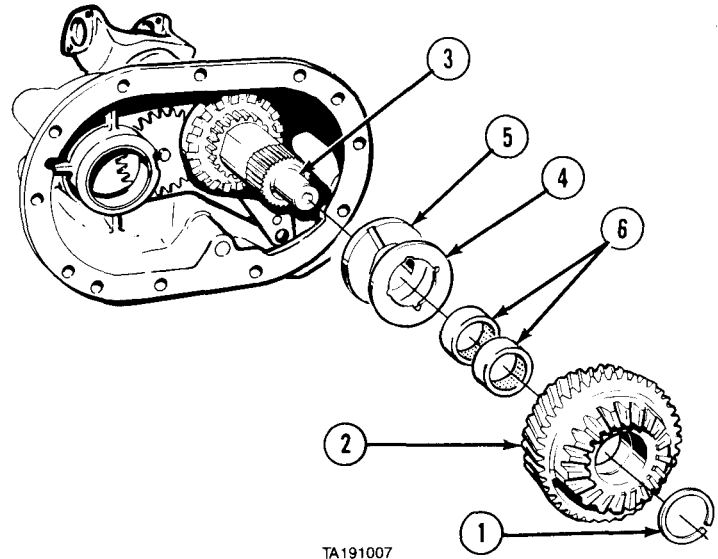

- (4) Matchmark lockout cover (7) and lockout body (8).
- (5) Remove four screws (9), lockwashers (10), and lockout cover (7).
- (6) Remove preformed packing (11) from lockout cover (7).

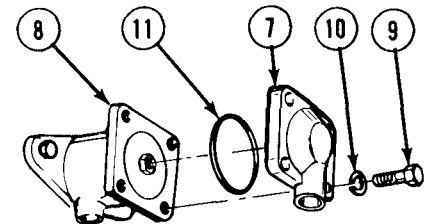
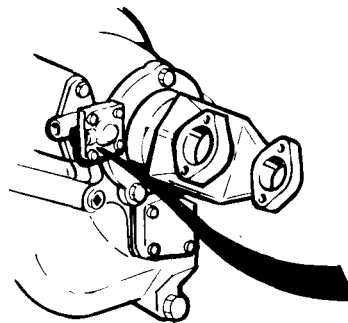

- (7) Remove nut (12) and washer (13).
- (8) Remove two screws (14), lockwashers (15), lockout body (8), and spring (16) from lockout fork (17).
- (9) Remove piston (18) from lockout body (8).
- (10) Remove two felt oilers (19), preformed packing (20), and preformed packing (21) from piston (18).

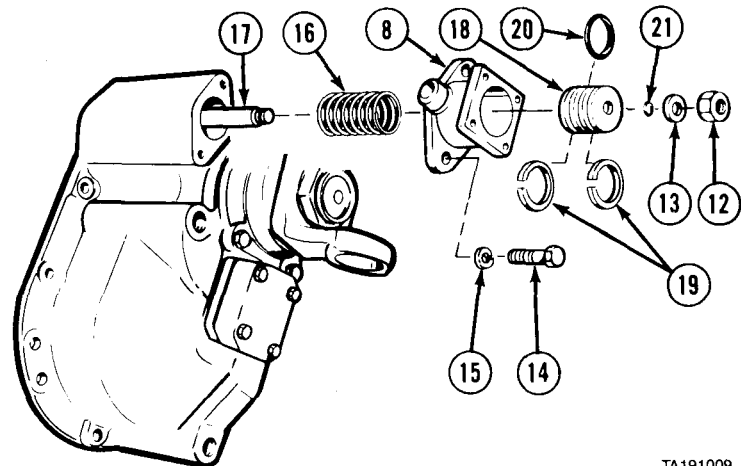

Axles No. 1 and No. 2 Maintenance Instructions (Cont)

9-9. DIFFERENTIAL CARRIER COVER, AXLE NO. 2 REPAIR (CONT).

- (11) Remove lockout fork (17) and lockout sliding clutch (22) from input shaft (3).
- (12) Remove locknut (23) from pump drive gear (24).
- (13) Remove pump drive gear (24) from differential carrier cover (25).

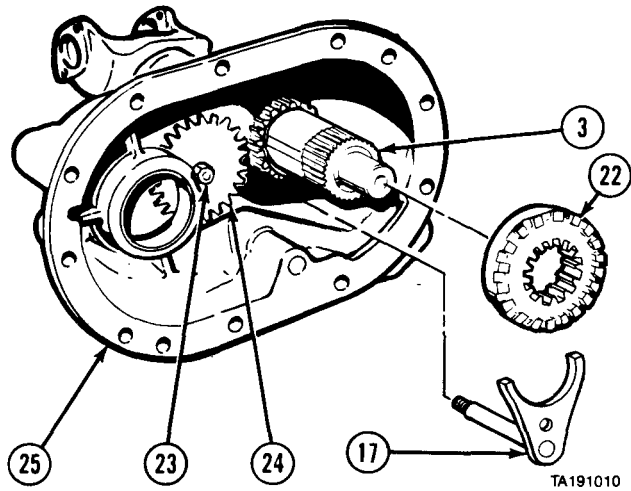

- (14) Remove four screws (26), lockwashers (27), and pump cover (28).
- (15) Remove preformed packing (29) from pump cover (28).

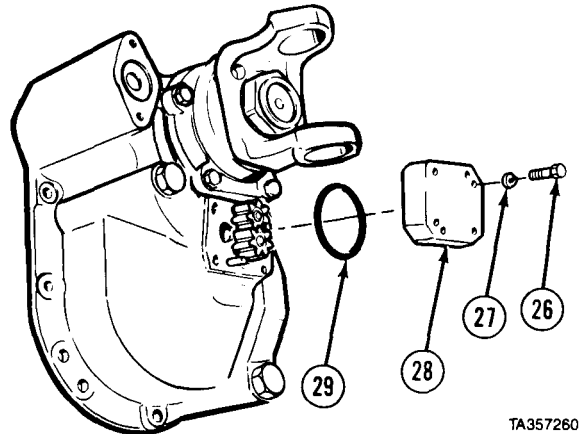

- (16) Remove threaded shaft (30) and shaft (31) from differential carrier cover (25).
- (17) Remove spacer (32) and two dowel pins (33).
- (18) Remove filter screen (34) and pipe plug (35) from differential carrier cover (25).

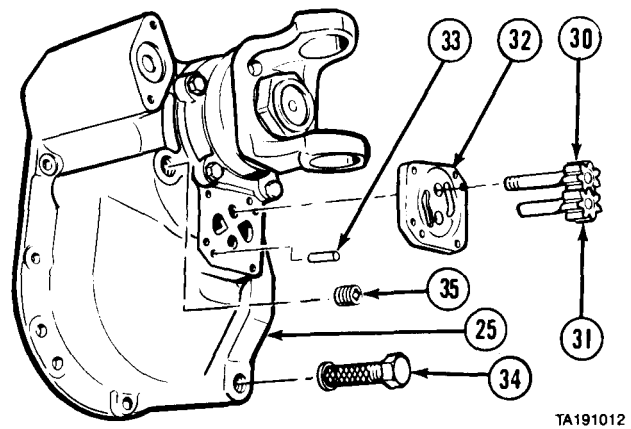

Axles No. 1 and No. 2 Maintenance Instructions (Cont)

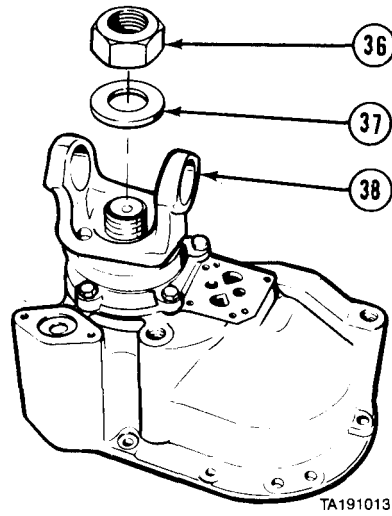

(19) Remove locknut (36), washer (37), and yoke (38).

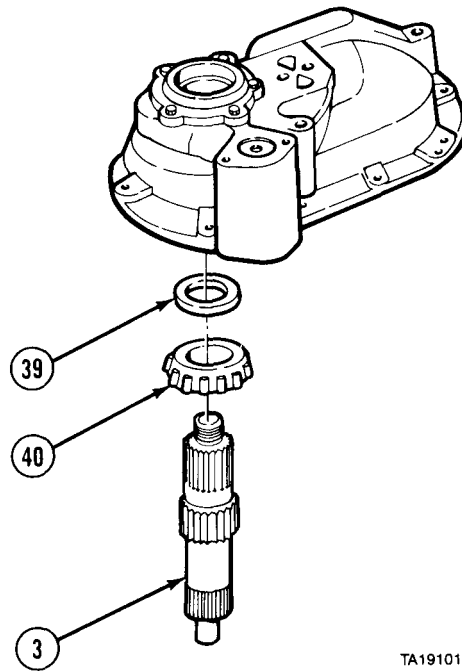

(20) Remove input shaft (3).

(21) Remove spacer (39) and bearing (40) from input shaft (3).

Axles No. 1 and No. 2 Maintenance Instructions (Cont)

9-9. DIFFERENTIAL CARRIER COVER, AXLE NO. 2 REPAIR (CONT).

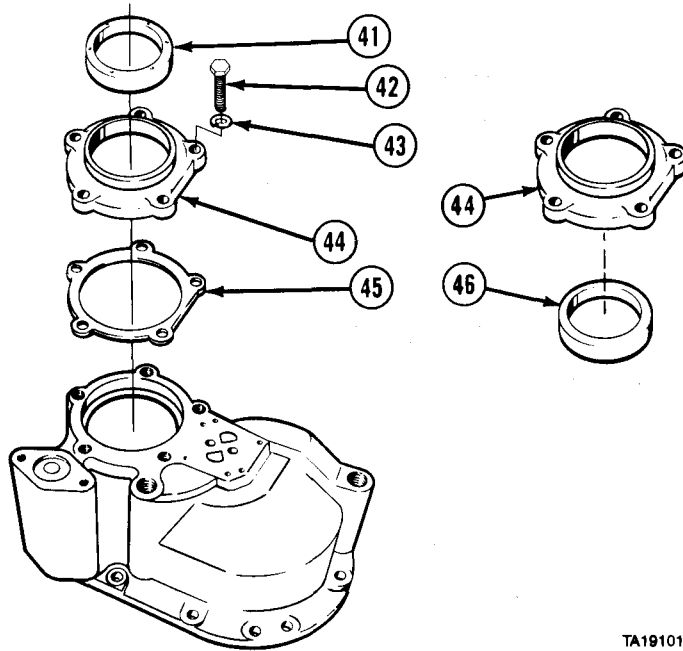

TA191015

- (22) Remove oil seal (41).
- (23) Remove five screws (42), lockwashers (43), bearing cover (44), and shims (45).
- (24) Remove bearing cup (46) from bearing cover (44).

NOTE

Support bearing and bearing race are provided as a set. Replace support bearing (para 9-12) whenever replacing bearing race.

- (25) Remove retaining ring (47) and bearing race (48) from inside differential carrier cover (25).
- (26) Remove expansion plug (49).

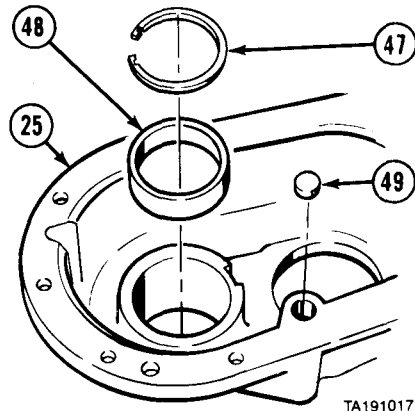

TA191017

Axles No. 1 and No. 2 Maintenance Instructions (Cont)

b. Cleaning/Inspection.

- (1) Scrape old sealant from differential carrier cover and differential carrier.

WARNING

Adhesives, solvents, and sealing compounds can burn easily, can give off harmful vapors, and are harmful to skin and clothing. To avoid injury or death, keep away from open fire and use in well-ventilated area. If adhesive, solvent, or sealing compound gets on skin or clothing, wash immediately with soap and water.

- (2) Clean all metal parts in dry cleaning solvent.
 (3) Allow bearings to air dry, then coat with lubricating oil.

WARNING

Compressed air used for cleaning purposes will not exceed 30 psi (207 kPa). Use only with effective chip guarding and personal protective equipment, goggles, shield, and gloves.

- (4) Use clean cloth or compressed air to dry all metal parts.
 (5) Inspect all metal parts for breaks, cracks, nicks, burrs, and sharp edges.
 (6) Inspect bearings for loose rollers and cracked or broken races.
 (7) Replace thrust washer removed from input shaft.
 (8) Replace two bushings removed from side gear.
 (9) Replace all damaged parts.

c. Assembly.

WARNING

Wear safety glasses to protect eyes from possible injury or blindness while installing retaining ring.

- (1) Install bearing race (1) and retaining ring (2) in differential carrier cover (3).
 (2) Install expansion plug (4).

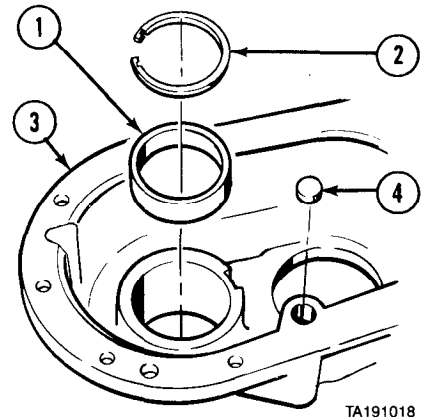

- (3) Install pipe plug (5) in differential carrier cover (3). Tighten to 40 to 60 lb-ft (54 to 81 N·m).
 (4) Install filter screen (6) in differential carrier cover (3). Tighten to 40 to 60 lb-ft (54 to 81 N·m).
 (5) Install two dowel pins (7) and spacer (8).

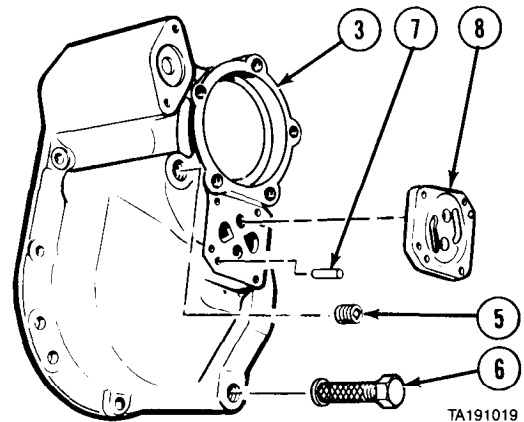

Axles No. 1 and No. 2 Maintenance Instructions (Cont)

9-9. DIFFERENTIAL CARRIER COVER, AXLE NO. 2 REPAIR (CONT).

- (6) Install preformed packing (9) in pump cover (10).
- (7) Lubricate and install threaded shaft (11) and shaft (12) in differential carrier cover (3).
- (8) Install pump cover (10), four lockwashers (13), and screws (14). Tighten screws to 85 to 102 lb-in (10 to 12 N·m).
- (9) Install pump drive gear (15) and locknut (16) on threaded shaft (11). Do not tighten.

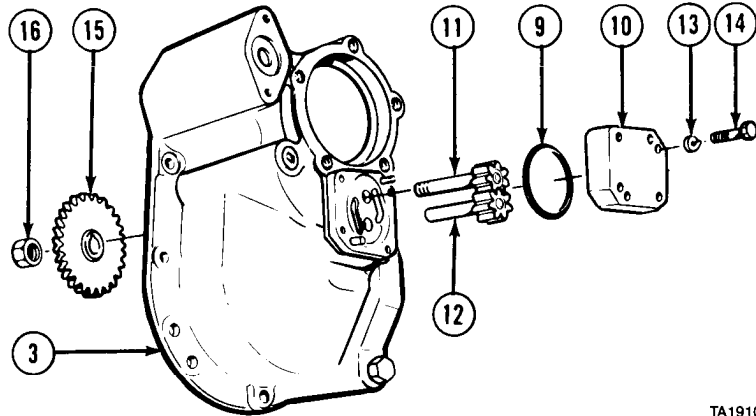

TA191020

- (10) Apply coat of oil on preformed packing (17). Install preformed packing on piston (18).
- (11) Soak two felt oilers (19) in oil and install felt oilers on piston (18).

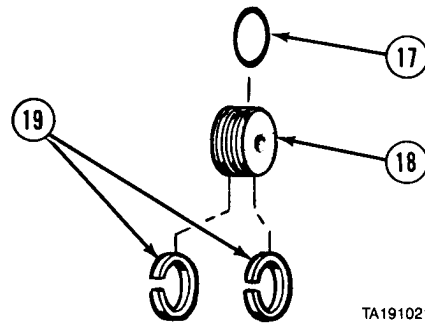

TA191021

WARNING

Adhesives, solvents, and sealing compounds can burn easily, can give off harmful vapors, and are harmful to skin and clothing. To avoid injury or death, keep away from open fire and use in well-ventilated area. If adhesive, solvent, or sealing compound gets on skin or clothing, wash immediately with soap and water.

- (12) Apply silicone adhesive-sealant on differential carrier cover (3) around mounting hole and screw holes for lockout body (20).
- (13) Install lockout body (20), two lockwashers (21), and screws (22) on differential carrier cover (3). Tighten screws to 48 to 56 lb-ft (65 to 76 N·m).
- (14) Install lockout fork (23) through back side of differential carrier cover (3) into lockout body (20).

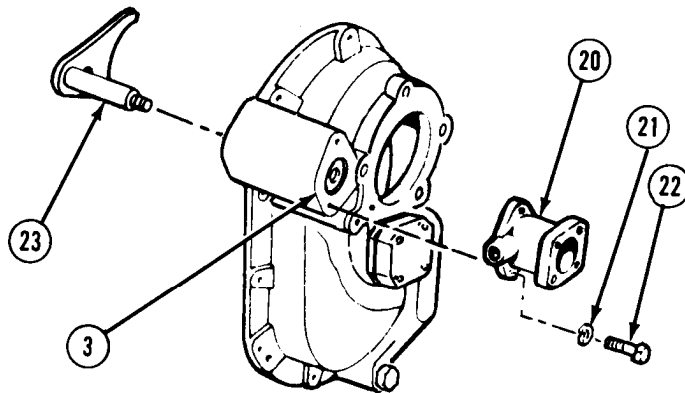

TA191022

Axles No. 1 and No. 2 Maintenance Instructions (Cont)

- (15) Install spring (24) and piston (18).
- (16) Push piston (18) against spring (24). Install preformed packing (25), washer (26), and nut (27) on lockout fork (23). Tighten nut to 20 to 26 lb-ft (27 to 35 N·m).

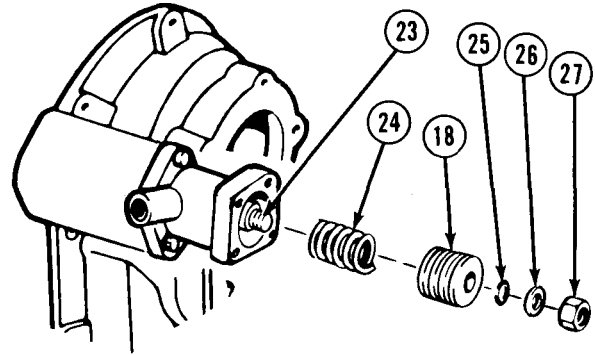

TA191023

- (17) Install preformed packing (28) in lockout cover (29).
- (18) Install four lockwashers (30), screws (31), and lockout cover (29) on lockout body (20). Tighten screws to 96 to 108 lb-in. (11 to 12 N·m).

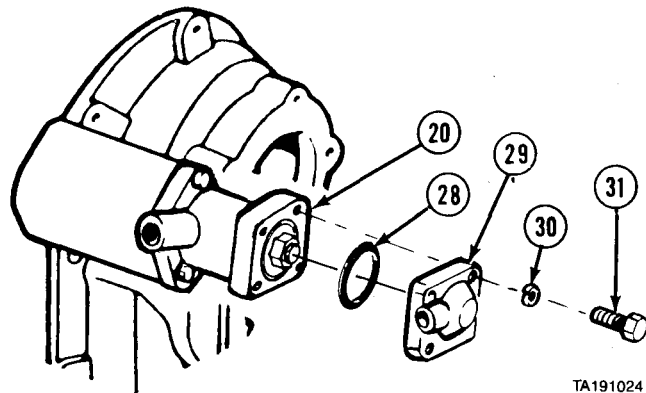

TA191024

CAUTION

Avoid damage to bearings by using press sleeve of proper size.

- (19) Install bearing (32) on input shaft (33).

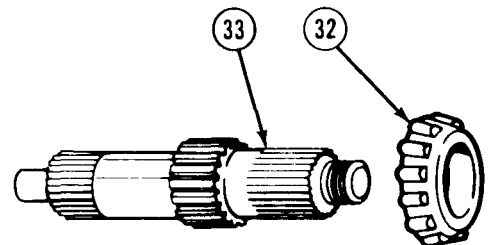

TA191025

- (20) Install two bushings (34) in helical side gear (35).

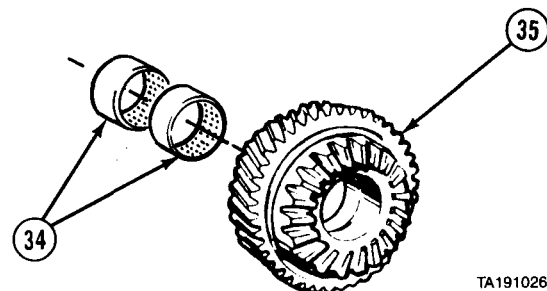

TA191026

Axles No. 1 and No. 2 Maintenance Instructions (Cont)

9-9. DIFFERENTIAL CARRIER COVER, AXLE NO. 2 REPAIR (CONT).

- (21) Install lockout sliding clutch (36) to engage lockout fork (23) inside differential carrier cover (3).
- (22) Install input shaft (33) through front of differential carrier cover (3) in lockout sliding clutch (36).

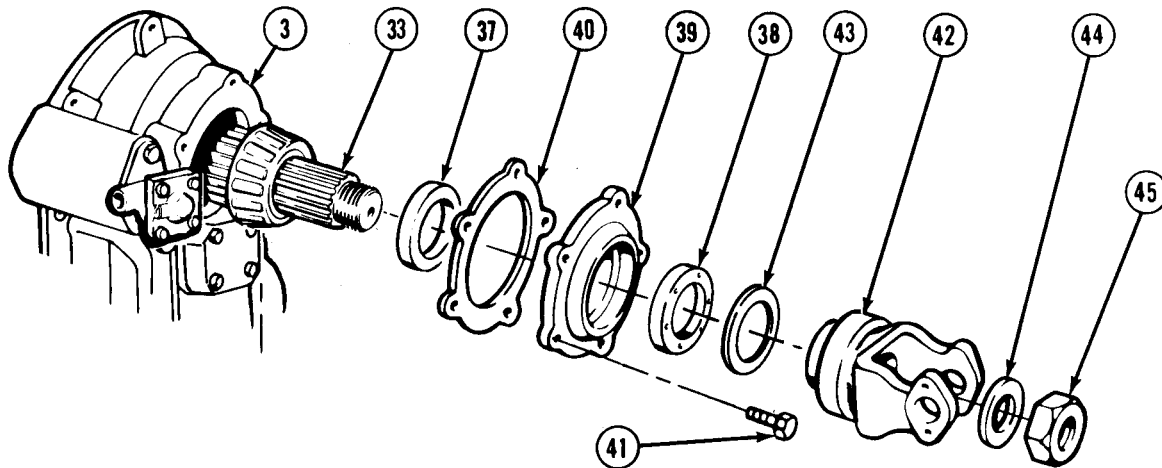
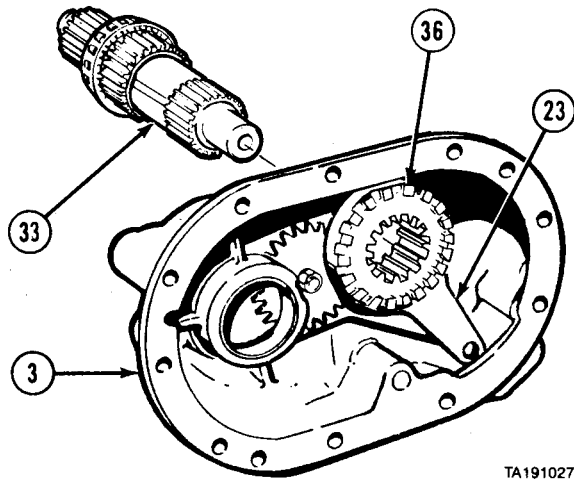

- (23) Install bearing cup (37) and oil seal (38) in bearing cover (39).
- (24) Apply sealing compound to bearing cover (39).
- (25) Aline holes in shims (40) with holes in bearing cover (39) and install shims, bearing cover, and five screws (41) on differential cover (3). Tighten screws to 75 to 85 lb-ft (102 to 115 N·m).
- (26) Apply sealing compound to outside diameter of bearing cover (39).
- (27) Lubricate shaft of yoke (42) and install spacer (43), yoke, washer (44), and locknut (45) on input shaft (33). Tighten locknut finger-tight.

Axles No. 1 and No. 2 Maintenance Instructions (Cont)

- (28) Tighten locknut (16) to 35 to 45 lb-ft (47 to 61 N•m).
- (29) install D-washer (46) and thrust washer (47) on input shaft (33).

WARNING

Wear safety glasses while installing retaining rings to protect eyes from possible injury or blindness.

- (30) Install helical side gear (35) and retaining ring (48) on input shaft (33).

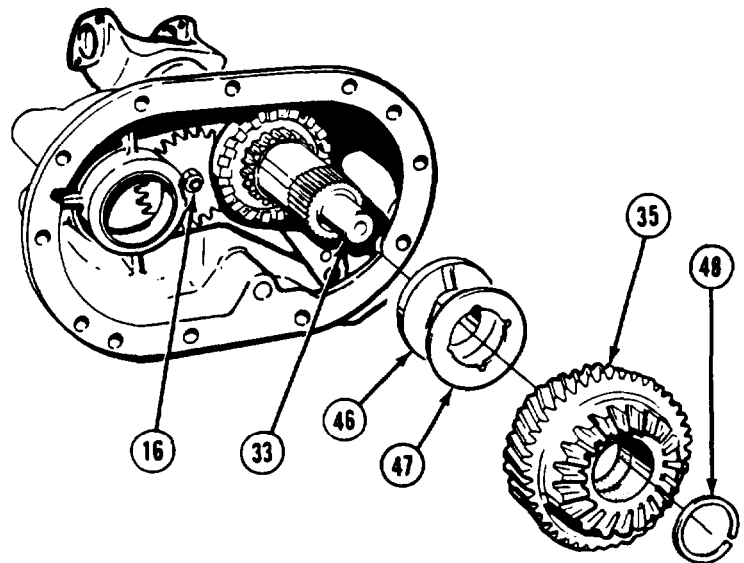

TA191029

d. Follow-on Maintenance. None.

END OF TASK

9-10. DIFFERENTIAL CARRIER, AXLE NO. 2 REMOVAL/INSTALLATION.	
This task covers:	
a. Removal	c. Installation
b. Cleaning/Inspection	d. Follow-on Maintenance
INITIAL SETUP	
<i>Models</i>	<i>Equipment Condition</i>
All	TM or Para
<i>Test Equipment</i>	Para 9-4
None	Para 9-5
<i>Special Tools</i>	Para 9-8
None	
<i>Supplies</i>	<i>Special Environmental Conditions</i>
Solvent, dry cleaning, Item 57, Appendix C	None
Adhesive-sealant, silicone, Item 6, Appendix C	<i>General Safety Instructions</i>
<i>Personnel Required</i>	None
MOS 63W, Wheel vehicle repairer (2)	<i>Level of Maintenance</i>
<i>References</i>	General Support
None	

Axles No. 1 and No. 2 Maintenance Instructions (Cont)

9-10. DIFFERENTIAL CARRIER, AXLE NO. 2 REMOVAL/INSTALLATION (CONT.).

a. Removal.

NOTE

- There are two models of axle housings: Model A and Model B. The differential carrier is mounted on Model A housing by two screws and 10 studs and nuts. The differential carrier is mounted on Model B housing by eight screws and four studs and nuts.

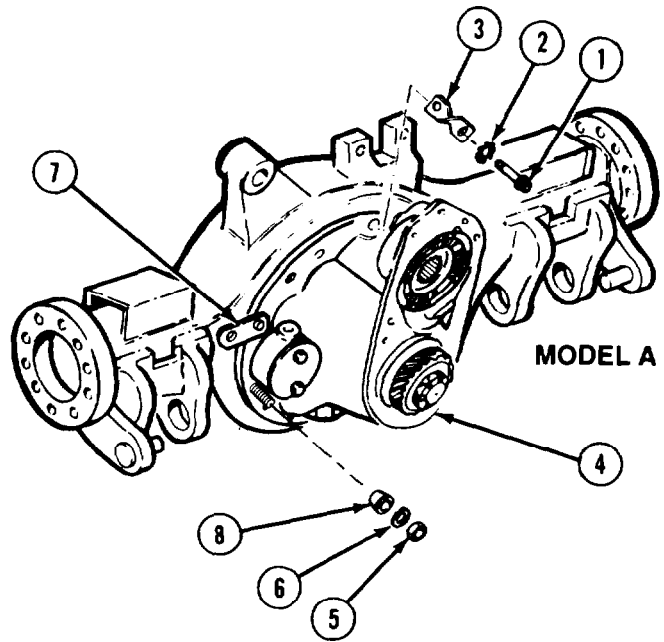

- Do steps (1) through (3) and (4) through (6) for Model A housing. Do steps (1) and (3.1) through (6) for Model B housing.

- (1) Remove two screws (1), lockwashers (2), and bracket (3) from differential carrier (4).
- (2) Remove 10 nuts (5), lockwashers (6), and two brackets (7).
- (3) Mark location and remove four tapered dowels (8).
- (3.1) Remove four nuts (5), lockwashers (6), and tapered dowels (8) from differential carrier.
- (3.2) Remove six screws (1), lockwashers (2), and two brackets (7).

WARNING

Keep out from under differential carrier. Serious injury may result if differential carrier falls from lifting device.

CAUTION

Do not strike differential carrier to loosen. Tap around edge of flange to avoid damage.

- (4) Attach lifting device to differential carrier (4).
- (5) Soldier A removes differential carrier (4) while Soldier B operates lifting device.
- (6) Mount differential carrier (4) on stand and fasten in place. Remove lifting device.

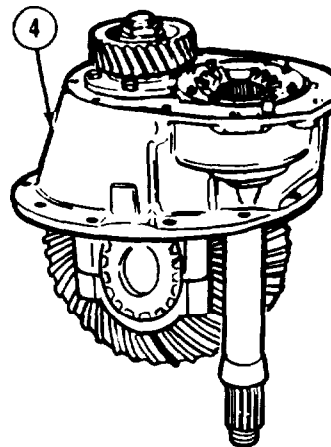

Axles No. 1 and No. 2 Maintenance Instructions (Cont)

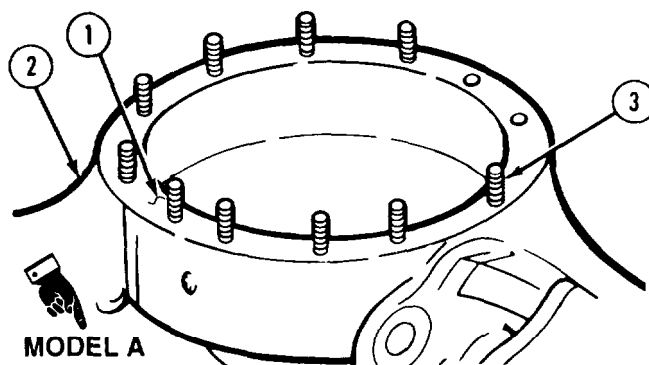
b. Cleaning/Inspection.

- (1) Scrape dirt and old sealant from mounting surface (1) on axle housing (2).

WARNING

Adhesives, solvents, and sealing compounds can burn easily, can give off harmful vapors, and are harmful to skin and clothing. To avoid injury or death, keep away from open fire and use in well-ventilated area. If adhesive, solvent, or sealing compound gets on skin or clothing, wash immediately with soap and water.

- (2) Use drycleaning solvent to clean axle housing (2).
 (3) Use clean cloth to wipe dry.
 (4) Inspect mounting studs (3) for cracks, breaks, and damaged threads. Replace if damaged.
 (5) Inspect axle housing (2) for cracks or damage. Replace if damaged.

c. Installation.**WARNING**

Keep out from under differential carrier. Serious injury may result if differential carrier falls from lifting device.

NOTE

There are two models of axle housings: Model A and Model B. The differential carrier is mounted on Model A housing by two screws and 10 studs and nuts. The differential carrier is mounted on Model B housing by eight screws and four studs and nuts.

Do steps (1) through (7), (8), and (9) for Model A housing. Do steps (1) through (6), (7.1) through (7.4), (8) and (9) for Model B housing.

- (1) Attach lifting device to differential carrier (1).
 (2) Soldier A removes differential carrier (1) from stand while Soldier B operates lifting device.

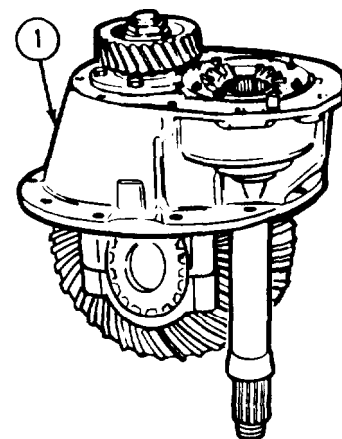

Axles No. 1 and No. 2 Maintenance instructions (Cont)

WARNING

Adhesives, solvents, and sealing compounds can burn easily, can give off harmful vapors, and are harmful to skin and clothing. To avoid injury or death, keep away from open fire and use in well-ventilated area. If adhesive, solvent, or sealing compound gets on skin or clothing, wash immediately with soap and water.

- (3) Apply silicone adhesive-sealant on inside edge of axle housing (2) mounting surface.

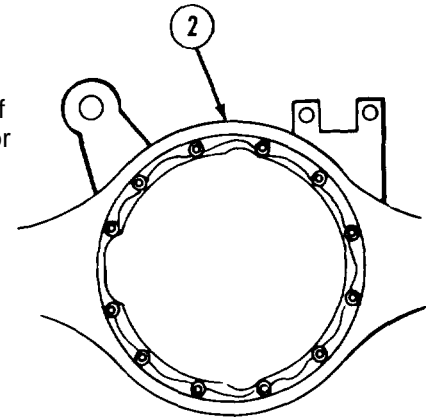

- (4) Soldier A installs differential carrier (1) in axle (2) while Soldier B operates lifting device.
- (5) Install bracket (3), two lockwashers (4), and screws (5).
- (6) Install four tapered dowels (6).
- (7) Install two brackets (7), 10 lockwashers (8), and nuts (9).
- (7.1) Install two brackets (7) and six lockwashers (4) and screws (5).
- (7.2) Install four tapered dowels (6), lockwashers (8), and nut (9).
- (7.3) Install bracket (3), two lockwashers (4), and screws (5).
- (7.4) Tighten all screws to 180 lb-ft (244 N•m).
- (8) Tighten screws (5) to 210 to 230 lb-ft (285 to 312 N•m).
- (9) Tighten nuts (9) to 150 to 170 lb-ft (203 to 231 N•m).

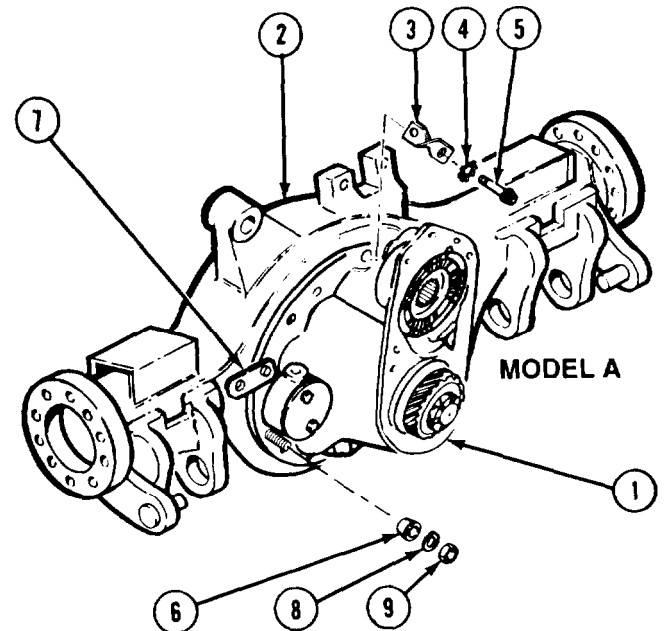

d. Follow-on Maintenance.

- (1) Install differential carrier cover (para 9-8).
- (2) Install axle housing cover assembly, No. 2 (para 9-5).
- (3) Install axle No. 2 (para 9-4).

END OF TASK

Axles No. 1 and No. 2 Maintenance Instructions (Cont)

9-11. DIFFERENTIAL CARRIER. AXLE NO. 1 REPAIR.	
This task covers:	
a. Disassembly	c. Assembly
b. Cleaning/Inspection	d. Follow-on Maintenance
INITIAL SETUP	
<i>Models</i> All	<i>Personnel Required</i> MOS 63W, Wheel vehicle repairer (2)
<i>Test Equipment</i> Indicator, dial Scale, spring, with attaching soft wire	<i>References</i> None
<i>Special Tools</i> Socket, 2 1/4-in. IM723	<i>Equipment Condition</i> TM or Para
<i>Supplies</i> Oil, lubricating, gear, Item 44, Appendix C Solvent, drycleaning, Item 57, Appendix C Dye, prussian blue, Item 32, Appendix C Lockwire, Item 39, Appendix C Adhesive-sealant, silicone, Item 6, Appendix C Compound, sealing, and thread locking, Item 25, Appendix C Compound, sealing, Item 28, Appendix C	<i>Condition Description</i> Differential carrier, axle No. 1 on clean work surface. <i>Special Environmental Conditions</i> None <i>General Safety Instructions</i> None <i>Level of Maintenance</i> General Support

Axles No. 1 and No. 2 Maintenance Instructions (Cont)

a. Disassembly.

(1) Check ring gear (1) backlash with dial indicator. Move ring gear back and forth to measure backlash. Record backlash.

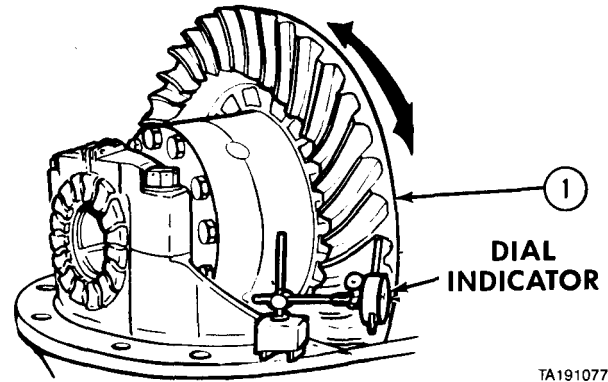

TA191077

(2) Check tooth contact pattern. Paint one-third of teeth on ring gear (1) with prussian blue dye. Roll ring gear one-third turn, then rock ring gear forward and backward to set pattern in dye. Record ring gear tooth pattern.

USED GEAR PATTERN

- POCKET MAY BE EXTENDED.
- PATTERN ALONG FACE WIDTH COULD BE LONGER.

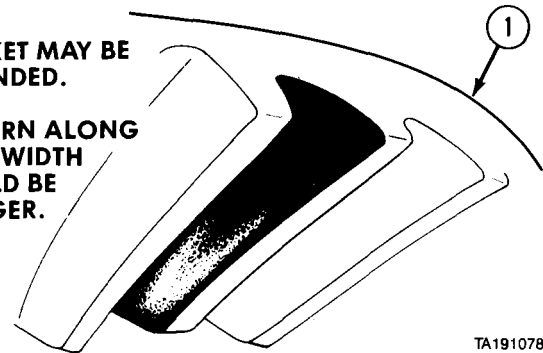

TA191078

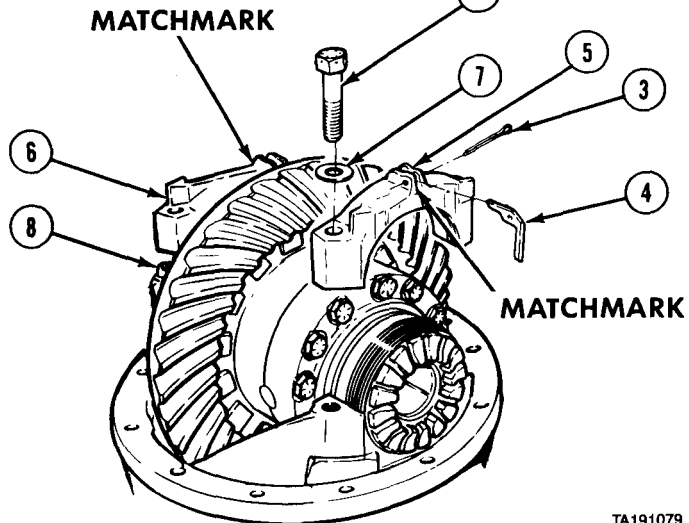
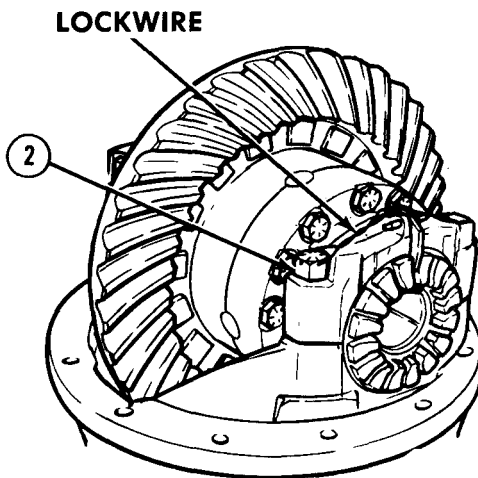

TA191079

- (3) Remove lockwire from four screws (2).
- (4) Remove two cotter pins (3) and adjuster locks (4) from bearing cap (5) and bearing cap (6). Matchmark center of bearing cap.
- (5) Remove four screws (2), washers (7), bearing cap (5), bearing cap (6), and two bushings (8). Matchmark center of bearing cap.

Axles No. 1 and No. 2 Maintenance Instructions (Cont)

9-11. DIFFERENTIAL CARRIER, AXLE NO. 1 REPAIR (CONT).

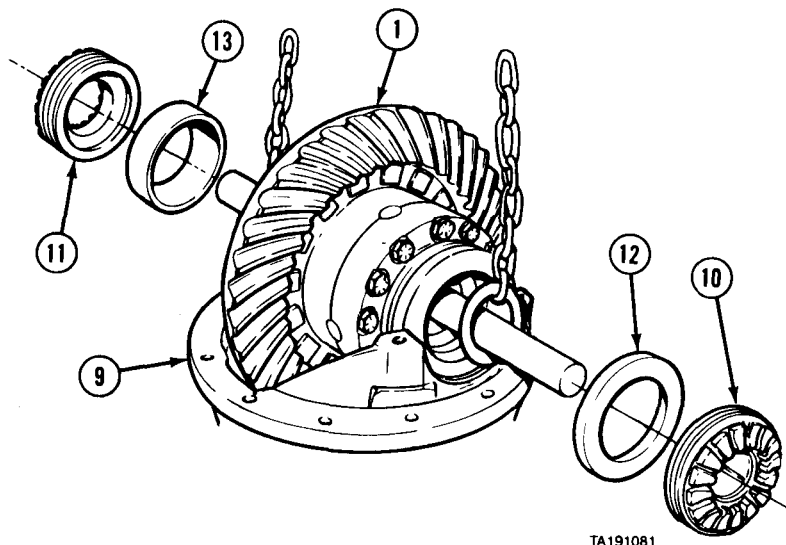

NOTE

Ring gear and assembled parts must be tilted to clear casting inside carrier.

- (6) Attach lifting device to ring gear (1) and assembled parts.
- (7) Soldier A removes ring gear (1) and assembled parts from differential carrier (9) while Soldier B operates lifting device.
- (8) Place ring gear (1) and assembled parts on clean work surface and remove lifting device.
- (9) Remove bearing adjusters (10 and 11) and bearing cups (12 and 13).
- (10) Soldier A and Soldier B place ring gear (1) and assembled parts, teeth up, on clean work surface.
- (11) Matchmark differential case flanged half (14) and differential case plain half (15).
- (12) Remove 12 screws (16) and differential case plain half (15).
- (13) Remove bearing cone (17) from differential case plain half (15).

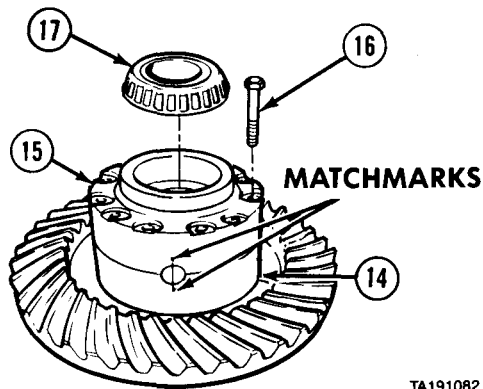

Axles No. 1 and No. 2 Maintenance Instructions (Cont)

- (14) Remove thrust washer (18) and side gear (19) from spider (20).
- (15) Remove spider (20) from differential case flanged half (14).
- (16) Remove four thrust washers (21) and side pinions (22) from spider (20).

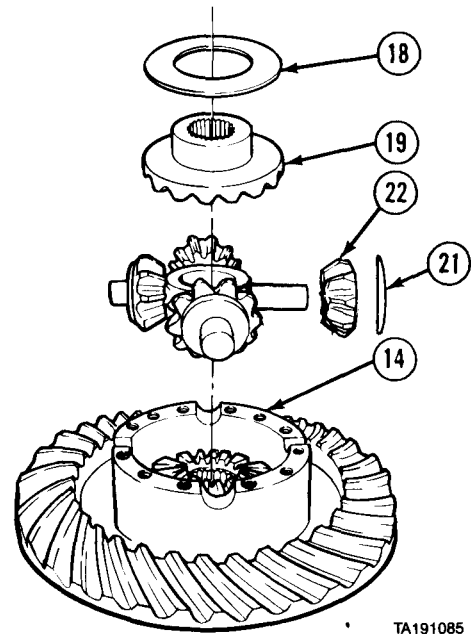

TA191085

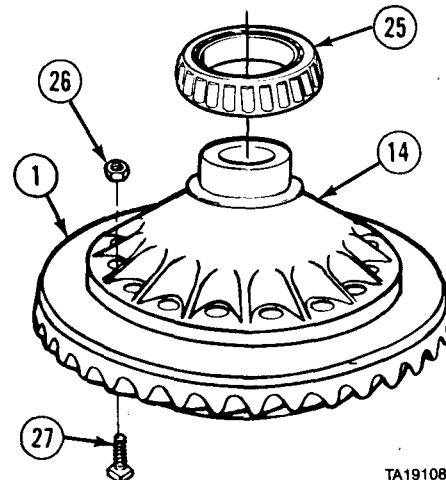
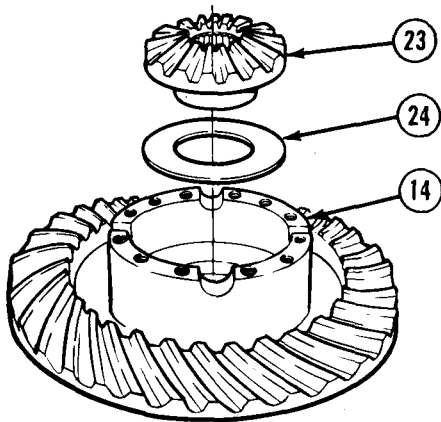

TA191087

- (17) Remove side gear (23) and thrust washer (24) from differential case flanged half (14).
- (18) Remove bearing cone (25) from differential case flanged half (14).

WARNING

Keep hands out from under ring gear. Do not allow ring gear to drop. Ring gear is heavy and can cause injury if dropped on hands.

- (19) Remove 16 nuts (26) and screws (27).
- (20) Remove ring gear (1) from differential case flanged half (14).

9-11. DIFFERENTIAL CARRIER, AXLE NO. 1 REPAIR (CONT.)

- (21) Matchmark bearing cage (28) and differential carrier (9).
- (22) Remove six screws (29) from bearing cage (28).
- (23) Remove bearing cage (28) and assembled parts from differential carrier (9).
- (24) Remove shims (30) from differential carrier (9). Record number and size of shims.
- (25) Remove locknut (31) from pinion (32).
- (26) Remove yoke (33) from pinion (32).

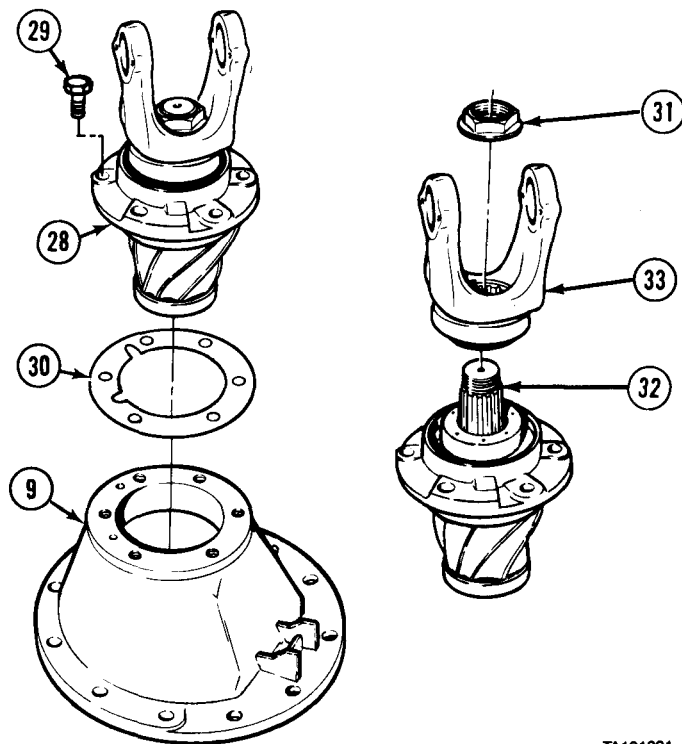

TA191091

- (27) Remove oil seal (34).
- (28) Press pinion (32) from bearing cage (28).
- (29) Remove outer bearing cone (35), outer bearing cup (36), and inner bearing cup (37) from bearing cage (28).

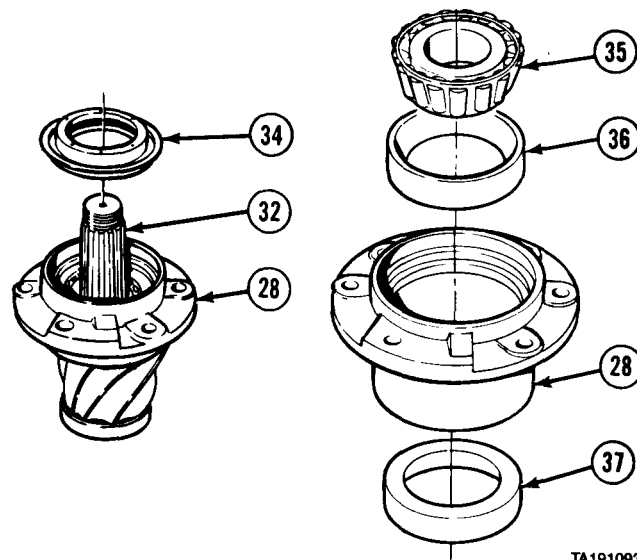

TA191093

Axles No. 1 and No. 2 Maintenance Instructions (Cont)

- (30) Remove spacer (38), spacer washer (39), and inner bearing cone (40) from pinion (32).
- (31) Remove pilot bearing (41) from pinion (32).

b. Cleaning/Inspection.

- (1) Scrape old sealant from differential carrier.

WARNING

Adhesives, solvents, and sealing compounds can burn easily, can give off harmful vapors, and are harmful to skin and clothing. To avoid injury or death, keep away from open fire and use in well-ventilated area. If adhesive, solvent, or sealing compound gets on skin or clothing, wash immediately with soap and water.

- (2) Clean all metal parts with dry cleaning solvent.

WARNING

Compressed air used for cleaning purposes will not exceed 30 psi (207 kPa). Use only with effective chip guarding and personal protective equipment, goggles, shield, and gloves.

- (3) Use clean, lint-free cloth or compressed air to dry all metal parts except bearings.
- (4) Allow bearings to air dry.
- (5) Inspect all metal parts for breaks, cracks, and sharp edges.
- (6) Inspect machined parts for nicks and burrs.
- (7) Inspect bearings for loose rollers and cracked or broken races.
- (8) Coat bearings with lubricating oil.
- (9) If pinion or ring gear is bad, replace both as a matched set.

c. Assembly.

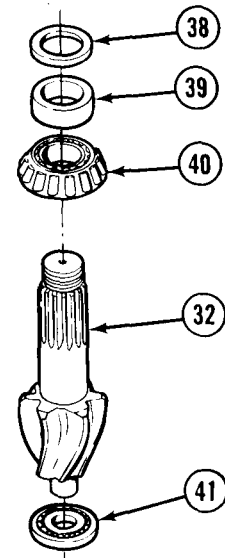

TA191095

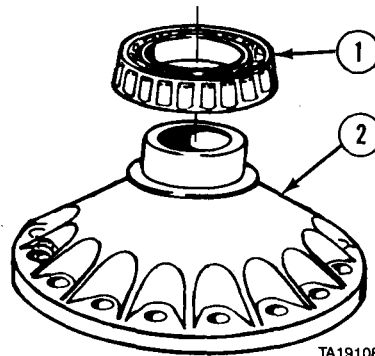

TA191088

- (1) Install bearing cone (1) on differential case flanged half (2).

Axles No. 1 and No. 2 Maintenance Instructions (Cont)

9-11. DIFFERENTIAL CARRIER, AXLE NO. 1 REPAIR (CONT).

(2) Install bearing cone (3) on differential case plain half (4).

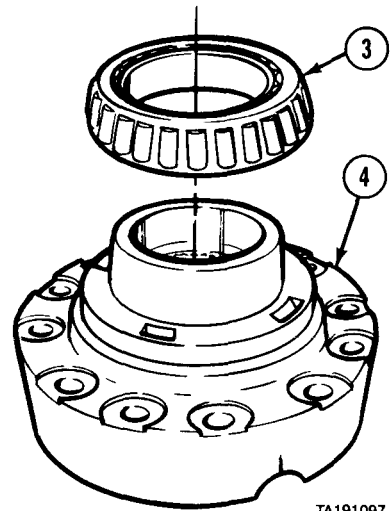

TA191097

(3) Install thrust washer (5) and side gear (6) in differential case flanged half (2).

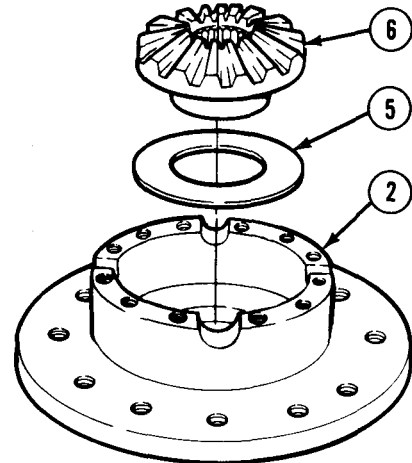

TA191098

(4) Lubricate spider (7) and install four side pinions (8) and thrust washers (9) on spider.

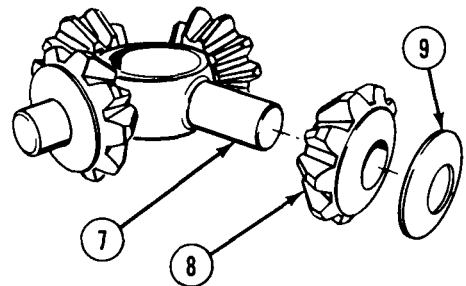

TA191099

Axles No. 1 and No.2 Maintenance Instructions (Cont)

- (5) Install spider (7) and assembled parts in differential case flanged half (2).
- (6) Turn side pinions (8) and make sure that side pinions move freely.
- (7) Install side gear (10) and thrust washer (11) on side pinions (8).

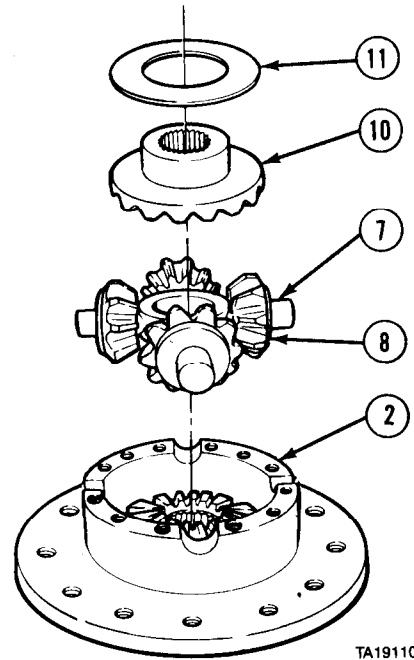

- (8) Aline matchmarks and install differential case plain half (4) on differential case flanged half (2).

WARNING

Adhesives, solvents, and sealing compounds can burn easily, can give off harmful vapors, and are harmful to skin and clothing. To avoid injury or death, keep away from open fire and use in well-ventilated area. If adhesive, solvent, or sealing compound gets on skin or clothing, wash immediately with soap and water.

NOTE

- Hub side gear should be hard to turn, but should turn smoothly with no binding or sticking.
- Place differential carrier in holding device before tightening screws.

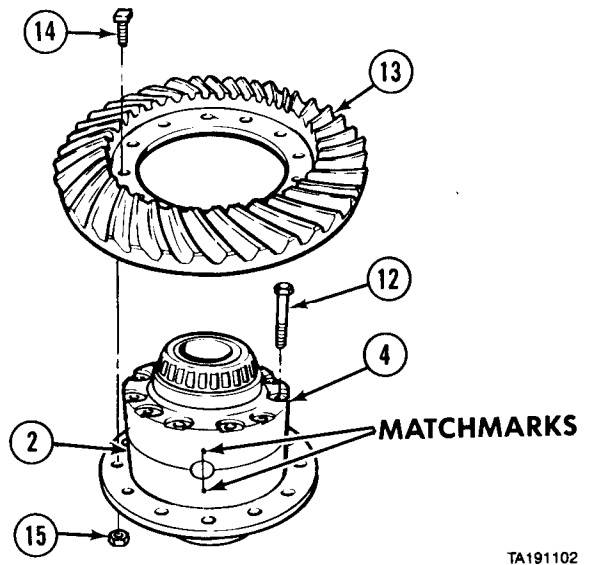

- (9) Apply sealing and thread locking compound and install 12 screws (12) in differential case plain half (4). Tighten screws equally to 165 to 195 lb-ft (224 to 264 N·m).

CAUTION

Square head of screw must be seated in machined groove of ring gear, otherwise ring gear or screws may be damaged.

- (10) Install ring gear (13) on differential case flanged half (2) with 16 screws (14) and nuts (15). Tighten nuts to 180 to 220 lb-ft (224 to 298 N·m).

Axles No. 1 and No. 2 Maintenance Instructions (Cont)

9-11. DIFFERENTIAL CARRIER, AXLE NO. 1 REPAIR (CONT).

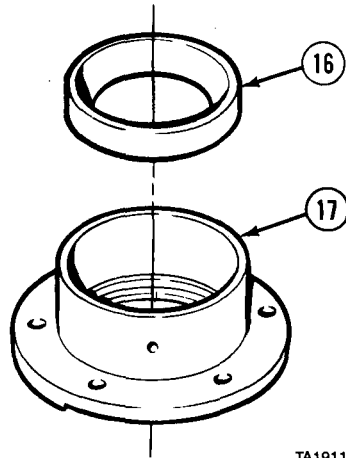

TA191103

(11) Install inner bearing cup (16) in bearing cage (17).

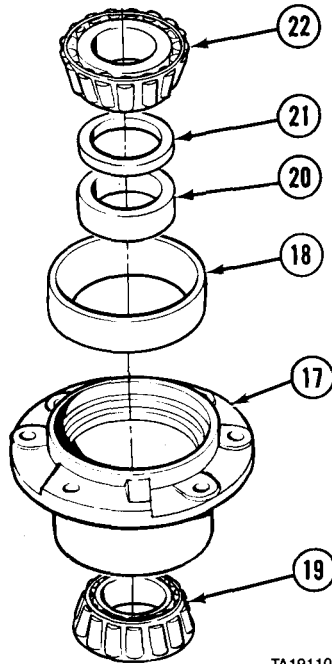

TA191104

- (12) Turn bearing cage (17) over.
- (13) Install outer bearing cup (18) in bearing cage (17).
- (14) Lubricate and install inner bearing cone (19).

NOTE

Use 0.185-in. (4.70 mm) spacer in step (15).

- (15) Install spacer washer (20) and spacer (21) in bearing cage (17).
- (16) Lubricate and install outer bearing cone (22) in outer bearing cup (18).

Axles No. 1 and No. 2 Maintenance Instructions (Cont)

(17) Position bearing cage (17) and assembled parts in press so outer bearing cone (22) is on top.

CAUTION

- Turn bearing cage back and forth while applying pressure to be sure bearings and bearing cups are well lubricated.
- If bearing cage becomes hard to turn while applying pressure, **STOP!** Bearings can be damaged if too much pressure is applied. Get next larger spacer and repeat step (18).

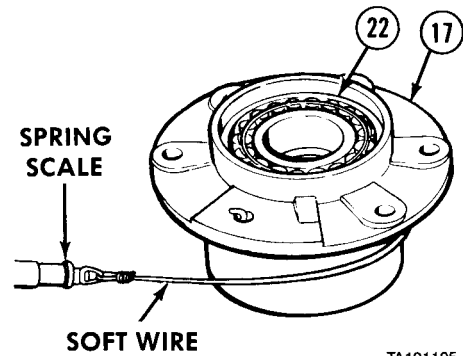

TA191105

(18) Lower press ram for load of 18.0 to 20.0 tons (16 to 18 metric tons).
 (19) Wrap soft wire around bearing cage (17) twice and fasten one end of wire in bearing cage screw hole. Fasten other end of wire to spring scale.
 (20) Pull on spring scale until bearing cage (17) begins to turn. Check that spring scale reads 3 to 7 lb (1.4 to 3.2 kg). If spring scale reading is correct, go to step (26). If reading is too low, go to step (24). If reading is too high, continue with step (21).

- (21) Remove outer bearing cone (22) and spacer (21) from bearing cage (17).
 (22) Use 0.001-in. (0.025 mm) thicker spacer (21) and install spacer and outer bearing cone (22) in bearing cage (17).
 (23) Repeat steps (17) through (20).
 (24) Remove outer bearing cone (22) and spacer (21). Use 0.001-in. (0.025 mm) thinner spacer and install spacer and outer bearing cone in bearing cage (17).
 (25) Repeat steps (17) through (20).

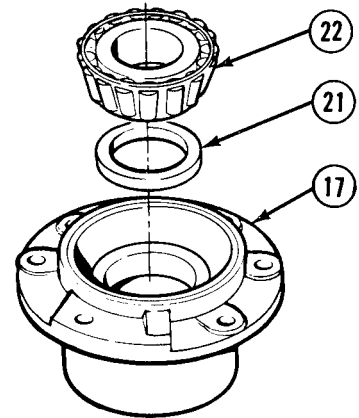

TA191106

- (26) Remove outer bearing cone (22), spacer (21), spacer washer (20), and inner bearing cone (19) from bearing cage (17).
 (27) Get spacer (21) 0.001-in. (0.025 mm) thicker than last spacer used and set aside.

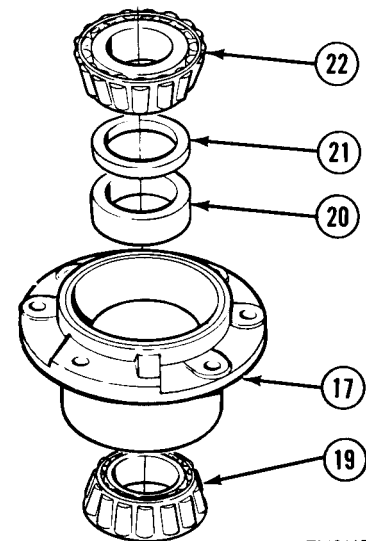

TA191107

9-11. DIFFERENTIAL CARRIER, AXLE NO. 1 REPAIR (CONT).

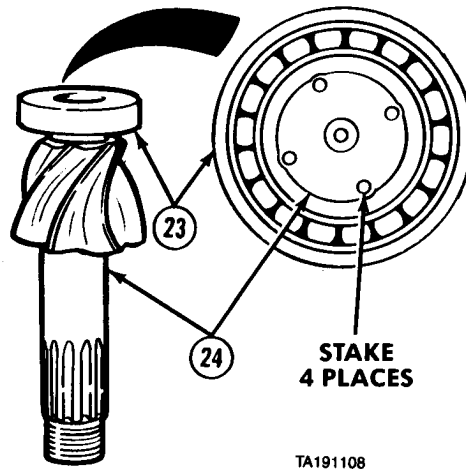

- (28) Lubricate and install pilot bearing (23) on pinion (24).
- (29) Stake pilot bearing (23) and pinion (24) as shown in pattern.

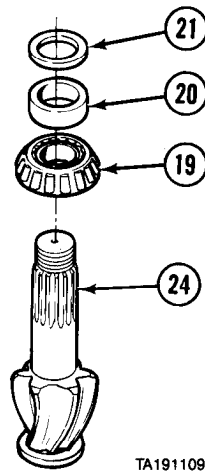

- (30) Lubricate and install inner bearing cone (19) on pinion (24).
- (31) Install spacer washer (20) and spacer (21) on pinion (24).

Axles No. 1 and No. 2 Maintenance Instructions (Cont)

- (32) Install bearing cage (17) on pinion (24).
- (33) Lubricate and install outer bearing cone (22) on pinion (24).
- (34) Install yoke (25) and locknut (26) on pinion (24). Tighten locknut to 840 to 1020 lb-ft (1 139 to 1 383 N·m).
- (35) Measure pinion bearing preload with yoke (25) in vise. Wrap soft wire around bearing cage (17) twice and fasten one end of wire in bearing cage screw hole. Fasten other end of wire to spring scale.
- (36) Pull on spring scale until bearing cage (17) begins to turn. Check that spring scale reads 5 to 12 lb (2.3 to 5.5 kg).
- (37) Remove locknut (26) and yoke (25). If reading is correct, go to step (48). If reading is too low, go to step (43). If reading is too high, go to step (38).

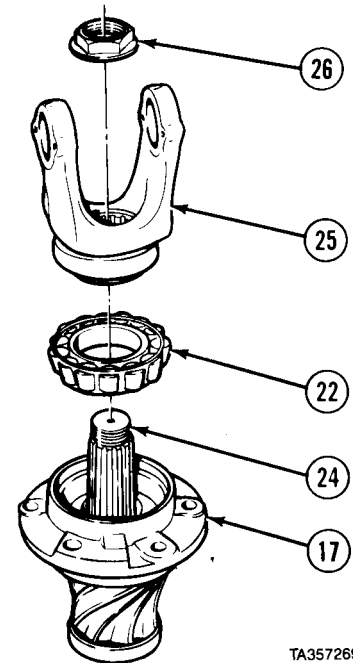

- (38) Remove pinion (24) from bearing cage (17).
- (39) Remove outer bearing cone (22) and spacer (21).
- (40) Install pinion (24) in bearing cage (17).
- (41) Use 0.001-in (0.025 mm) thicker spacer (21) and install spacer and outer bearing cone (22) on pinion (24).
- (42) Repeat steps (34) through (37).
- (43) Remove pinion (24) from bearing cage (17).
- (44) Remove outer bearing cone (22) and spacer (21).
- (45) Install pinion (24) in bearing cage (17).
- (46) Use 0.001-in (0.025 mm) thinner spacer (21) and install spacer and outer bearing cone (22) on pinion (24).
- (47) Repeat steps (34) through (37).
- (48) Install oil seal (27), yoke (25), and locknut (26) on pinion (24). Tighten locknut to 840 to 1020 lb-ft (1 139 to 1 383 N·m).

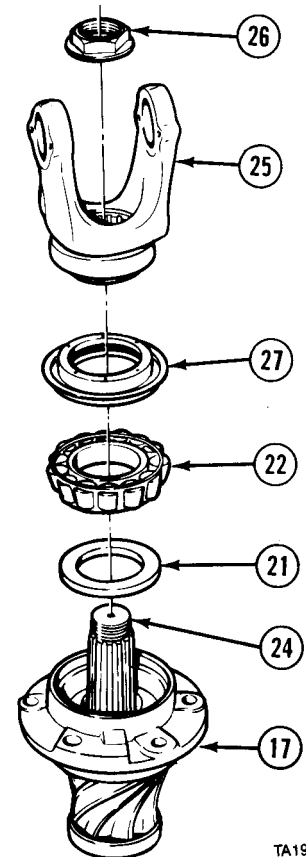

9-11. DIFFERENTIAL CARRIER, AXLE NO. 1 REPAIR (CONT).

WARNING

Adhesives, solvents, and sealing compounds can burn easily, can give off harmful vapors, and are harmful to skin and clothing. To avoid injury or death, keep away from open fire and use in well-ventilated area. If adhesive, solvent, or sealing compound gets on skin or clothing, wash immediately with soap and water.

(49) Apply sealing compound to flange of cage (17) and differential carrier (28).

NOTE

If gear set is reused, install same shims as removed. If new gear set is used, install 0.023-in. (0.6 mm) shim pack.

(50) Install shims (29) on differential carrier (28).

(51) Aline matchmarks and install bearing cage (17) on differential carrier (28).

(52) Apply thread locking compound and install six screws (30) to differential carrier (28). Tighten screws to 160 to 176 lb-ft (217 to 239 N·m).

(53) Apply coat of sealing compound around outside edge of shims (29).

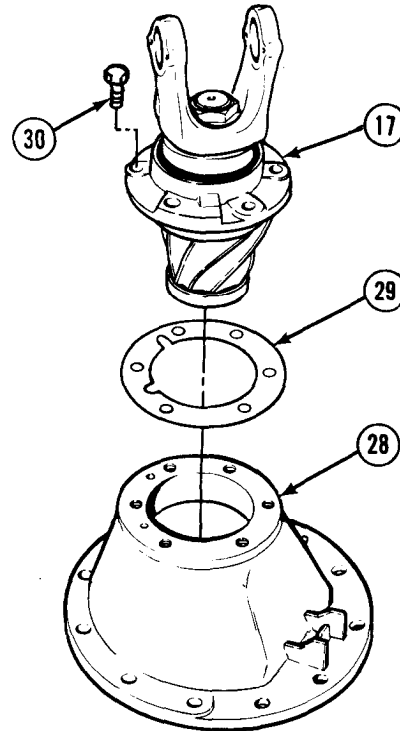

TA191113

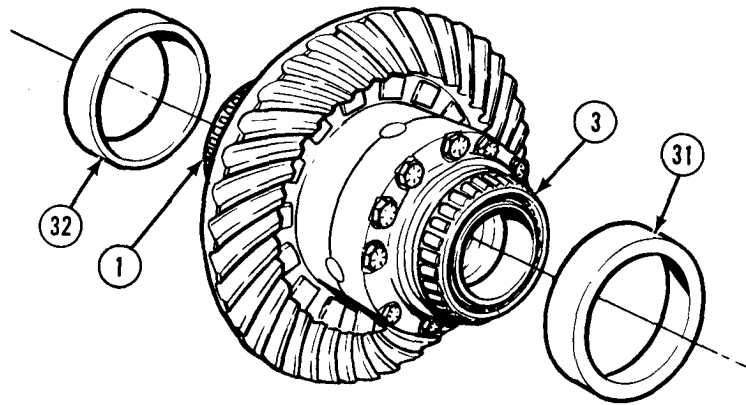

TA191115

(54) Lubricate bearing cones (1 and 3) with oil and install bearing cups (31 and 32) on bearing cones.

Axles No. 1 and No. 2 Maintenance Instructions (Cont)

NOTE

Ring gear must be tilted to clear casting inside carrier.

- (55) Attach suitable lifting device to ring gear (13).
- (56) Soldier A guides assembled ring gear (13) into differential carrier (28) until ring gear teeth mesh with pinion inside carrier while Soldier B operates lifting device.
- (57) Remove lifting device.

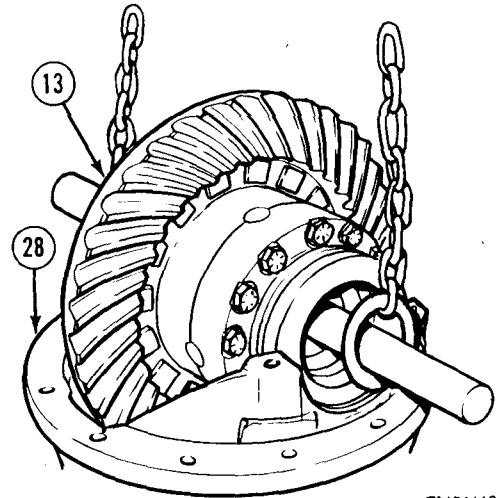

TA191116

- (58) Install bearing cap (33), two washers (34), and screws (35) on differential carrier (28). Tighten screws finger-tight.
- (59) Install two bushings (36), bearing cap (37), two washers (34), and screws (35). Tighten screws finger-tight.

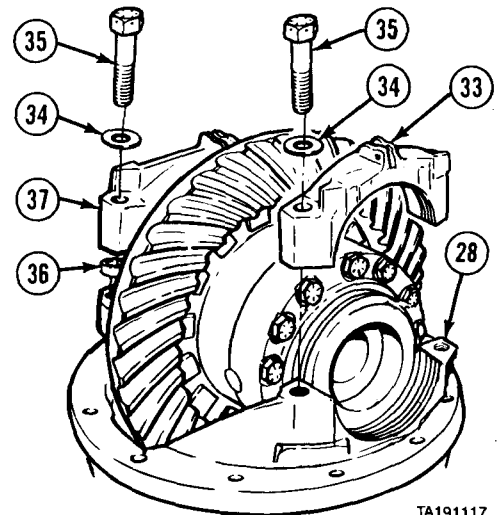

TA191117

CAUTION

Threads on bearing adjusters can be damaged if bearing adjusters are not installed carefully.

- (60) Install bearing adjuster (38) finger-tight.
- (61) Install bearing adjuster (39) finger-tight.
- (62) Tighten four screws (35) to 40 to 50 lb-ft (54 to 68 N·m).

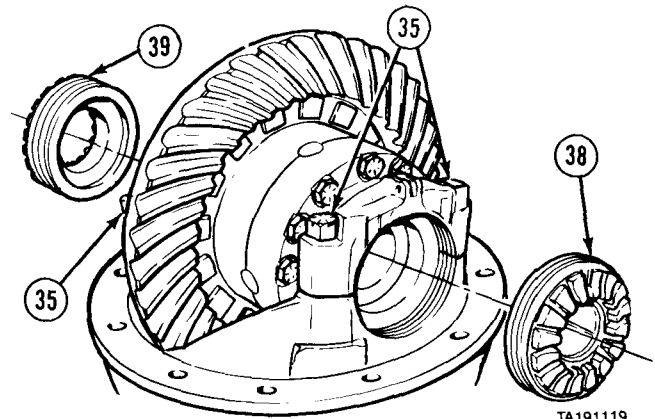

TA191119

Axles No. 1 and No. 2 Maintenance Instructions (Cont)

NOTE

Aline notch in bearing adjusters with mark on bearing caps.

- (63) Tighten bearing adjuster (38) until one thread shows.
- (64) Tighten bearing adjuster (39) until ring gear (13) cannot be rocked back and forth toward two bearing adjusters (38 and 39) and there is no backlash.
- (65) Rotate ring gear (13) and check for bind. If ring gear binds, loosen bearing adjuster (39) then tighten until ring gear does not bind.
- (66) Tighten bearing adjuster (38) until bearing adjuster contacts bearing cup or resists turning.
- (67) Tighten bearing adjuster (38) two or three notches until ring gear (13) has backlash.

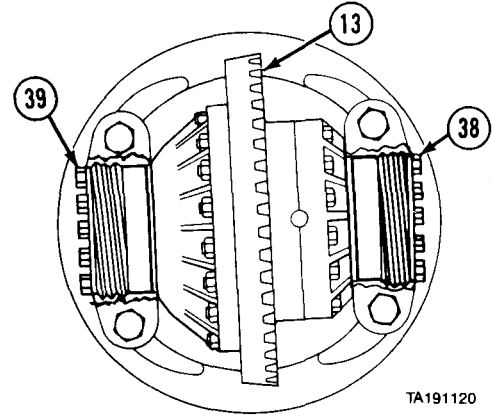

TA191120

NOTE

If old pinion and ring gear are used, backlash should be the same as recorded in disassembly step (1). If new pinion and ring gear are used, backlash should be 0.008 to 0.018 in. (0.203 to 0.457 mm).

- (68) Move ring gear (13) back and forth to measure backlash. If backlash is correct, go to step (77). If there is too much backlash, go to step (73). If there is not enough backlash, continue with step (69).

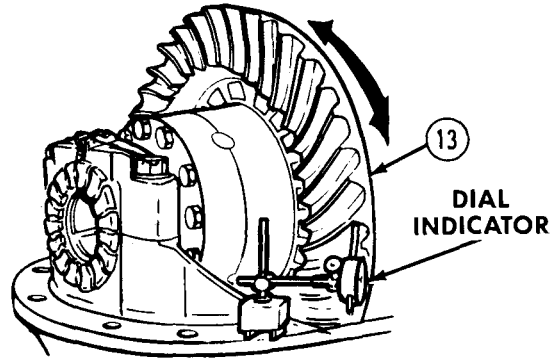

TA191121

- (69) To add backlash, loosen bearing adjuster (38) five or six notches.
- (70) Loosen bearing adjuster (39) one notch.
- (71) Tighten bearing adjuster (38) until bearing adjuster resists movement, then tighten two or three more notches.
- (72) Repeat step (68).
- (73) To remove backlash, loosen bearing adjuster (38) five or six notches.
- (74) Tighten bearing adjuster (39) one notch.
- (75) Tighten bearing adjuster (38) until bearing adjuster resists movement, then tighten two or three more notches.
- (76) Repeat step (68).

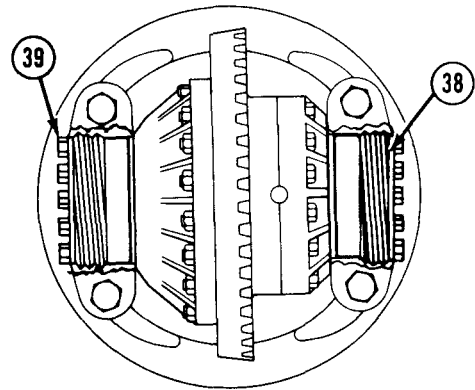

TA191122

Axles No. 1 and No. 2 Maintenance Instructions (Cont)

- (77) Paint one-third of teeth on ring gear (13) with prussian blue dye.
- (78) Roll ring gear (13) one-third turn, then rock ring gear forward and backward to set pattern in dye.

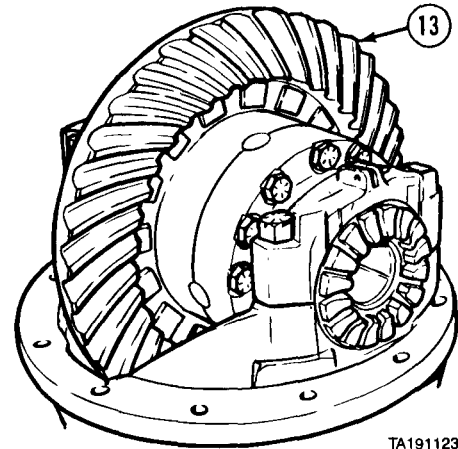

TA191123

CORRECT PATTERN (NEW GEARING)

- **COULD VARY IN LENGTH. PATTERN SHOULD COVER 1/2 TOOTH OR MORE (FACE WIDTH).**
- **PATTERN SHOULD BE EVENLY CENTERED BETWEEN TOOTH TOP LAND AND ROOT.**

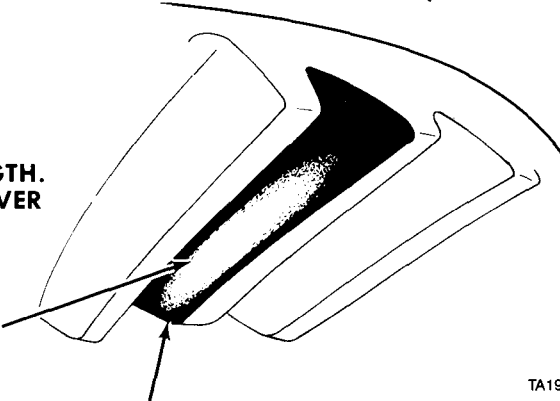

TA191124

- **PATTERN SHOULD BE CLEAR OF TOOTH TOE.**

NOTE

- A correct gear pattern for a used pinion and ring gear is clear of the toe and centers evenly along the face of gear tooth, but can be any length and shape and is acceptable as long as pattern does not run off gear tooth at any point.
- If gear pattern was correct at disassembly, then gear pattern after assembly should be the same.
- If pattern is not the same, review steps (80) through (83) and adjust backlash as required until pattern that was recorded at disassembly is reached.
- If pattern was incorrect (pattern runs off gear tooth) at disassembly then, after assembly, review steps (80) through (83) and adjust backlash as required until correct gear pattern (pattern does not run off gear teeth) is reached.
- Remember, a correct gear pattern for a used pinion and ring gear does not have to match PATTERN A (correct pattern for new gearing).
- If new pinion and ring gear are used, tooth pattern should be like correct pattern A above. If tooth pattern does not look like A, check pattern B through E to find one that looks close to ring gear tooth pattern, then do step that follows incorrect pattern.

- (79) If tooth contact is like pattern A, do not adjust. Go to step (84).

Axles No. 1 and No. 2 Maintenance Instructions (Cont)

9-11. DIFFERENTIAL CARRIER, AXLE NO. 1 REPAIR (CONT).

(80) If tooth contact is like pattern B, add backlash, steps (69) through (72). Repeat steps (77) and (78).

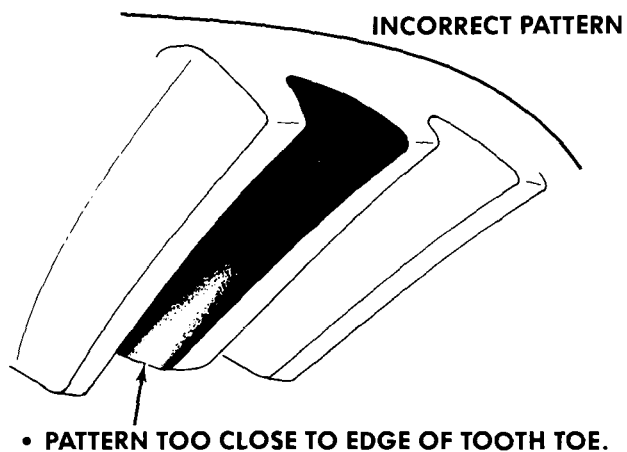

PATTERN B

TA191125

(81) If tooth contact pattern is like pattern C, remove backlash, steps (73) through (76). Repeat steps (77) and (78).

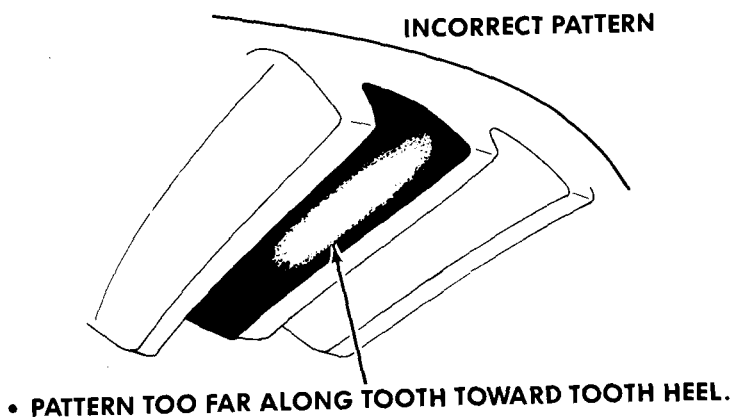

PATTERN C

TA191126

NOTE

To add or remove shims in steps (82) and (83), remove ring gear and differential assembly (steps (4) through (9) in Disassembly) and pinion (steps (20) through (22) in Disassembly). Add or remove shims, then install pinion, ring gear, and differential assembly (steps (49) through (67)).

(82) If tooth contact is like pattern D, move pinion closer to ring gear (13) by removing shims. Repeat steps (68) through (79).

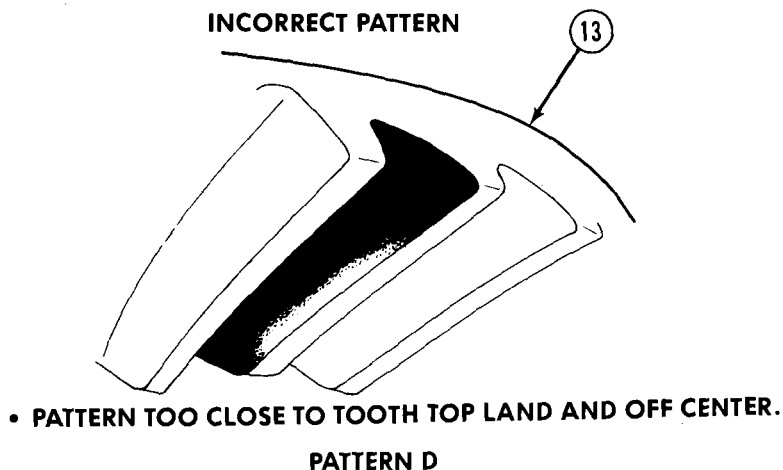

PATTERN D

TA191127

Axles No. 1 and No. 2 Maintenance Instructions (Cont)

(83) If tooth contact is like pattern E, move pinion away from ring gear (13) by adding shims. Repeat steps (68) through (79).

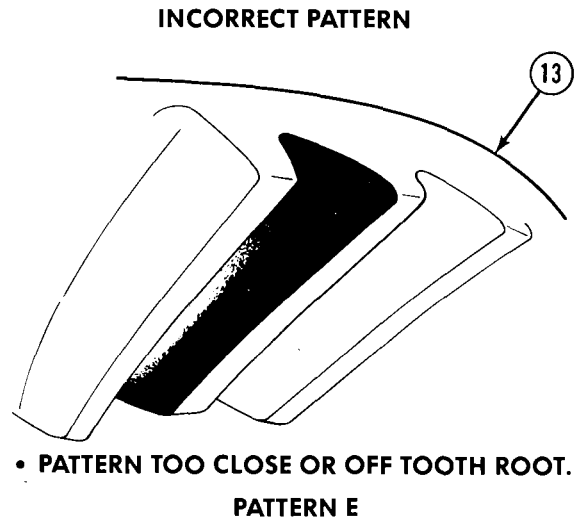

TA191128

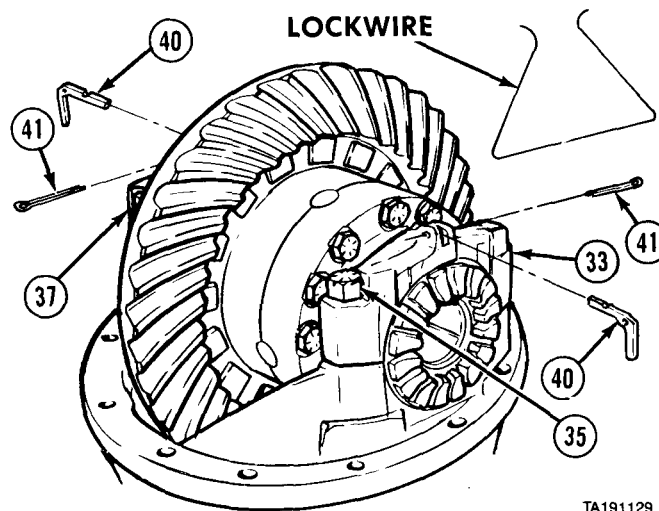

(84) Tighten four screws (35) to 370 to 430 lb-ft (502 to 583 N·m).

NOTE

Bearing adjuster may be turned slightly to aline lock.

- (85) Install adjuster lock (40) and cotter pin (41) on bearing cap (33).
- (86) Install adjuster lock (40) and cotter pin (41) on bearing cap (37).
- (87) Install lockwire on four screws (35).

d. Follow-on Maintenance. None.

END OF TASK

Axles No. 1 and No. 2 Maintenance Instructions (Cont)

9-12. DIFFERENTIAL CARRIER, AXLE NO. 2 REPAIR.

This task covers:

- a. Disassembly
- b. Cleaning/Inspection
- c. Assembly
- d. Follow-on Maintenance

INITIAL SETUP

Models

All

Test Equipment

Indicator, dial
Scale, spring, with attaching soft wire

Special Tools

None

Supplies

Oil, lubricating, gear, Item 44, Appendix C
Solvent, dry cleaning, Item 57, Appendix C
Dye, prussian blue, Item 32, Appendix C
Lockwire, Item 39, Appendix C
Adhesive-sealant, silicone, Item 6, Appendix C
Compound, sealing and thread locking, Item 25, Appendix C
Compound, sealing, Item 28, Appendix C

Personnel Required

MOS 63W, Wheel vehicle repairer (2)

References

None

Equipment Condition

<i>TM or Para</i>	<i>Condition Description</i>
	Differential carrier, axle No. 2 on clean work surface.

Special Environmental Conditions

None

General Safety Instructions

None

Level of Maintenance

General Support

a. Disassembly.

WARNING

Edges of inter-axle differential are very sharp. Wear gloves while handling to avoid personal injury.

- (1) Remove inter-axle differential (1).
- (2) Remove output shaft (2) and assembled parts from differential carrier (3).

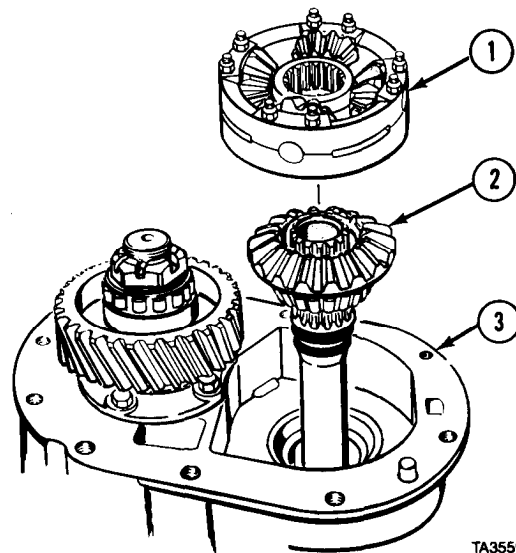

TA355927

Axles No. 1 and No. 2 Maintenance Instructions (Cont)

- (3) Matchmark inter-axle differential case halves (4 and 5).
- (4) Remove eight screws (6) and locknuts (7).
- (5) Separate two case halves (4 and 5).
- (6) Remove four thrust washers (8), side pinions (9), and bushings (10) from spider (11).

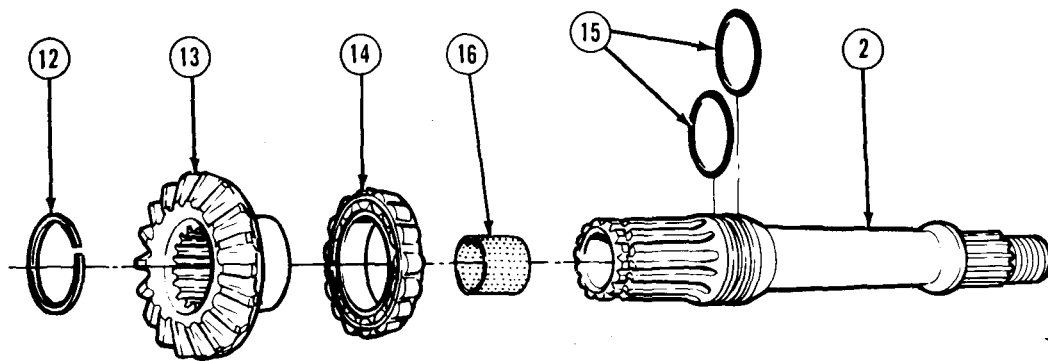
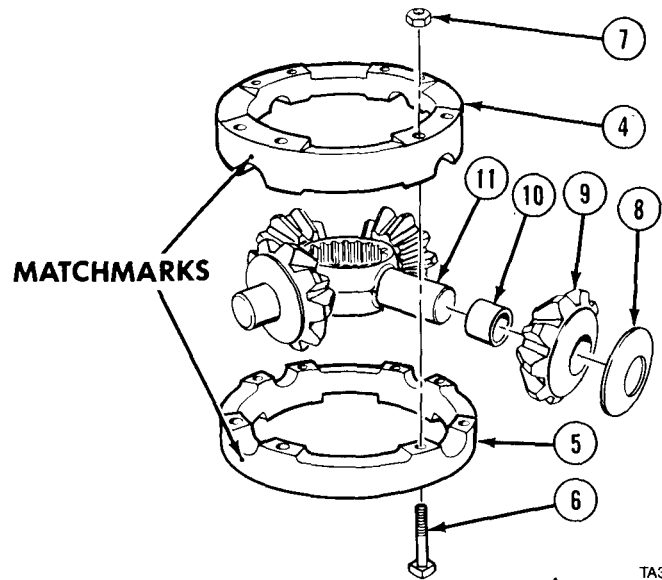

WARNING

Wear safety glasses while removing retaining rings to protect eyes from possible injury or blindness.

- (7) Remove retaining ring (12), side gear (13), and bearing cone (14) from output shaft (2).
- (8) Remove bearing cone (14) from side gear (13).
- (9) Remove two preformed packings (15) from output shaft (2).
- (10) Remove bushing (16) from output shaft (2).

Axles No. 1 and No. 2 Maintenance Instructions (Cont)

9-12. DIFFERENTIAL CARRIER, AXLE NO. 2 REPAIR (CONT).

(11) Check ring gear (17) backlash with dial indicator. Move ring gear back and forth to measure backlash. Record backlash.

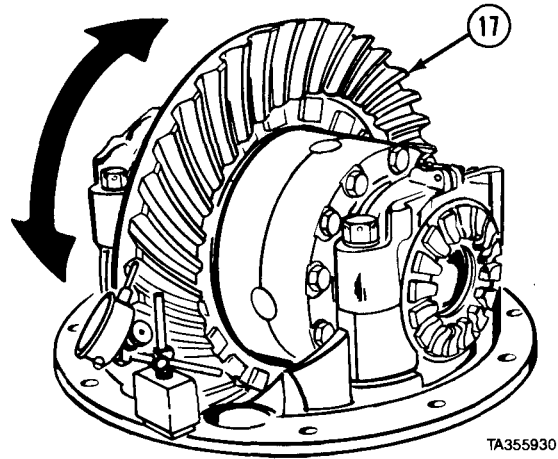

(12) Check tooth contact pattern. Paint one-third of teeth on ring gear (17) with prussian blue dye. Roll ring gear one-third turn, then rock ring gear forward and backward to set pattern in dye. Record ring gear tooth pattern.

• POCKET MAY BE EXTENDED.

• PATTERN ALONG FACE WIDTH COULD BE LONGER.

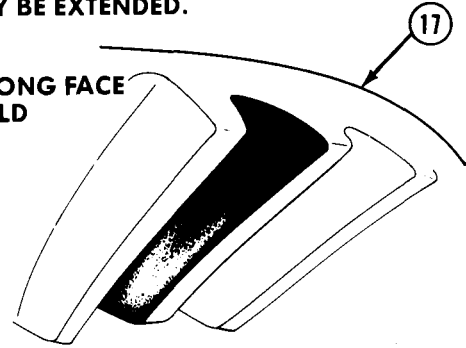

- (13) Remove roll pin (18).
- (14) Loosen locknut (19).
- (15) Remove bearing cup (20) from differential carrier (3).

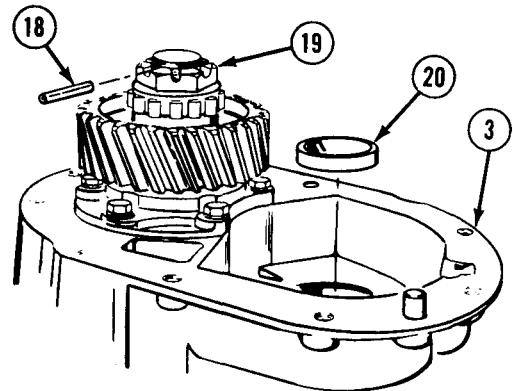

Axles No. 1 and No. 2 Maintenance Instructions (Cont)

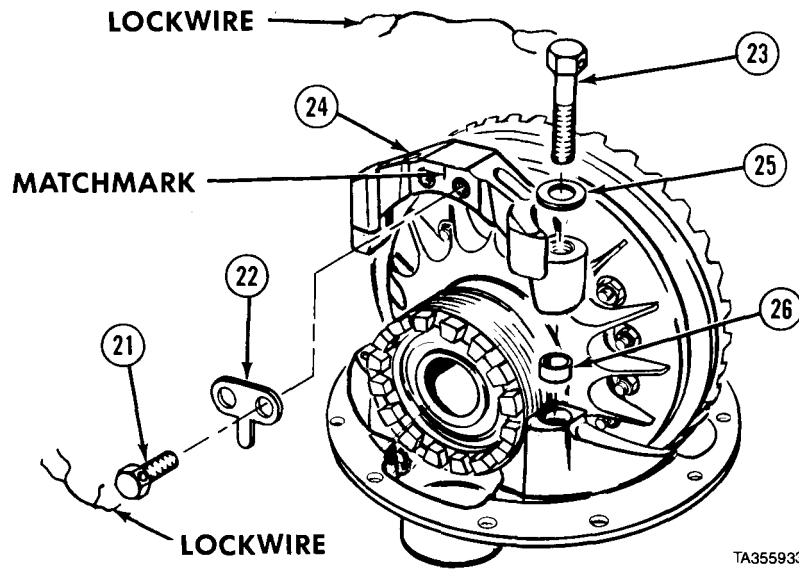

- (16) Remove lockwire from two screws (21).
- (17) Remove two screws (21) and adjuster lock (22).
- (18) Remove lockwire from two screws (23).
- (19) Matchmark center of bearing cap (24) and remove two screws (23), washers (25), and bearing cap.
- (20) Remove two bushings (26).

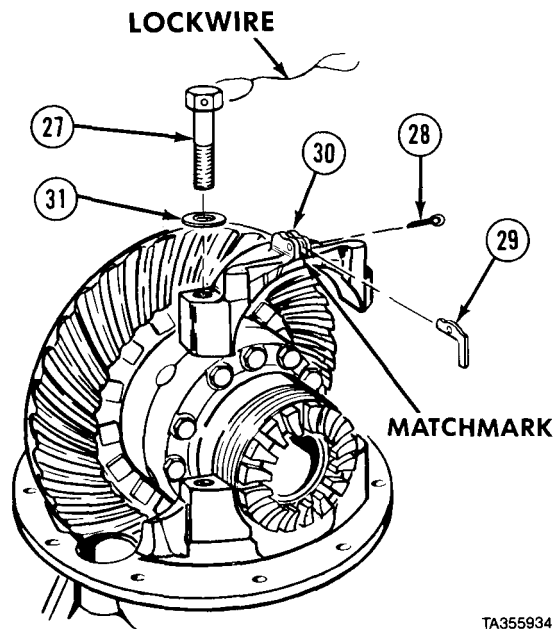

- (21) Remove lockwire from two screws (27).
- (22) Remove cotter pin (28) and adjuster lock (29) from bearing cap (30).
- (23) Matchmark center of bearing cap (30) and remove two screws (27), washers (31), and bearing cap.

Axles No. 1 and No. 2 Maintenance Instructions (Cont)

9-12. DIFFERENTIAL CARRIER, AXLE NO. 2 REPAIR (CONT).

WARNING

Side of ring gear away from gear teeth must be lifted first to prevent gear from catching on carrier casting.

- (24) Soldier A removes ring gear (17) and differential (32) as an assembly from differential carrier (3) while Soldier B operates lifting device.
- (25) Place ring gear on clean work surface and remove lifting device.

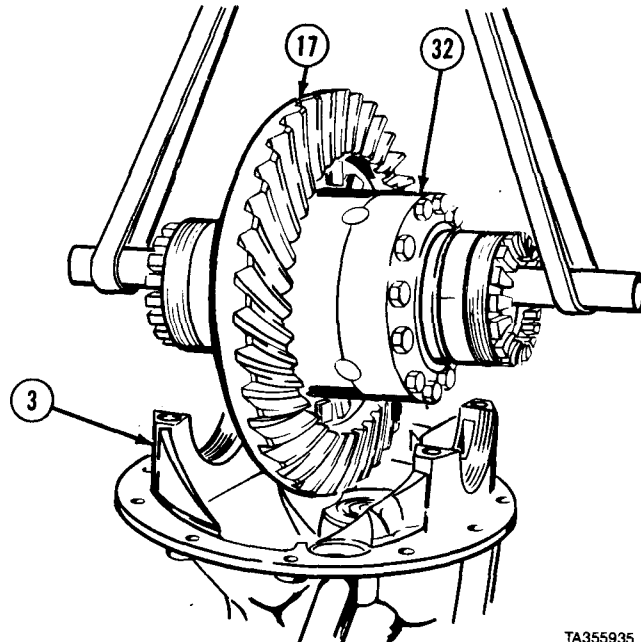

TA355935

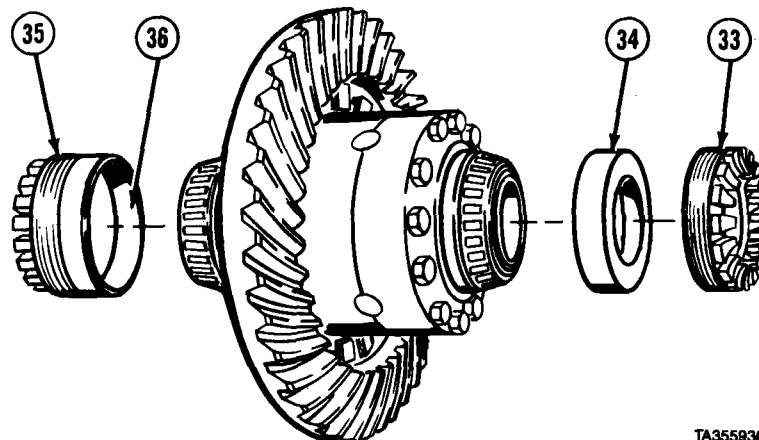

TA355936

- (26) Remove bearing adjuster (33) and bearing cup (34).
- (27) Remove bearing adjuster (35) and bearing cup (36) as an assembly.

Axles No. 1 and No. 2 Maintenance Instructions (Cent)

(28) Remove bearing cup (36) from bearing adjuster (35).

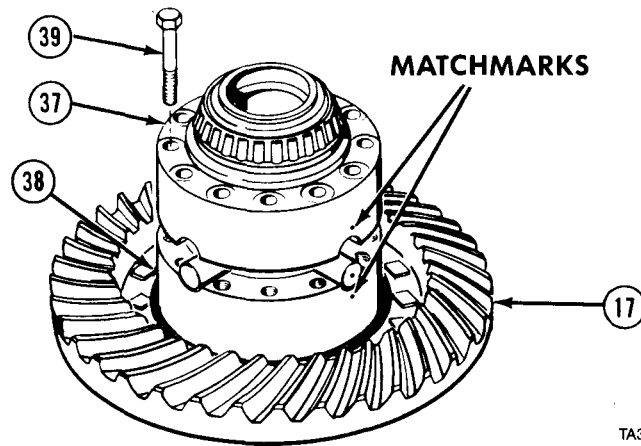
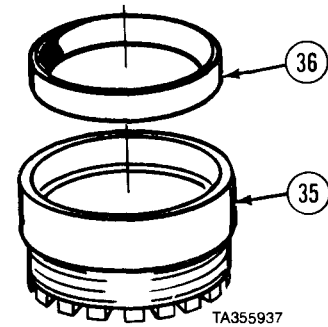

(29) Position ring gear (17), teeth up, on clean work surface.

(30) Matchmark differential case plain half (37) and differential case flanged half (38).

(31) Remove 12 screws (39) and differential case plain half (37).

(32) Remove bearing cone (40) from differential case plain half (37).

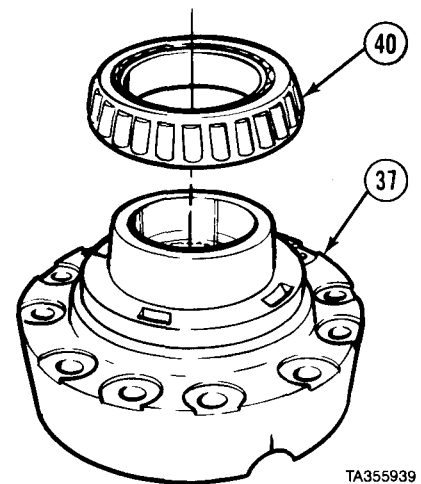

Axles No. 1 and No. 2 Maintenance Instructions (Cont)

9-12. DIFFERENTIAL CARRIER, AXLE NO. 2 REPAIR (CONT).

- (33) Remove thrust washer (41) and side gear (42) from spider (43).
- (34) Remove spider (43) from differential case flanged half (38).

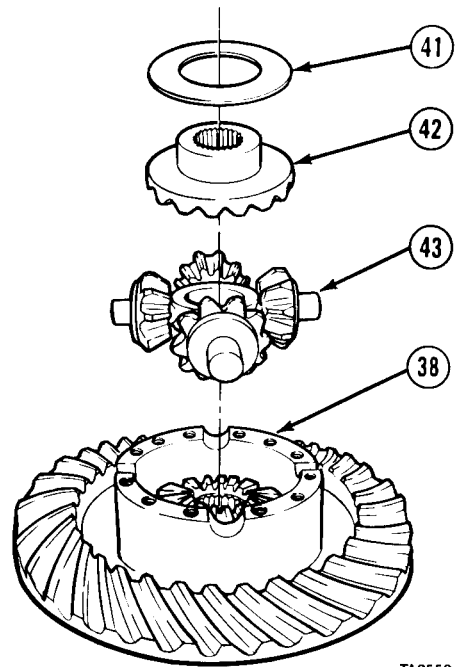

TA355940

- (35) Remove four thrust washers (44) and side pinions (45) from spider (43).

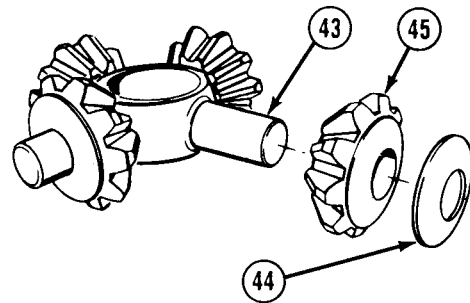

TA355942

- (36) Remove side gear (46) and thrust washer (47) from differential case flanged half (38).

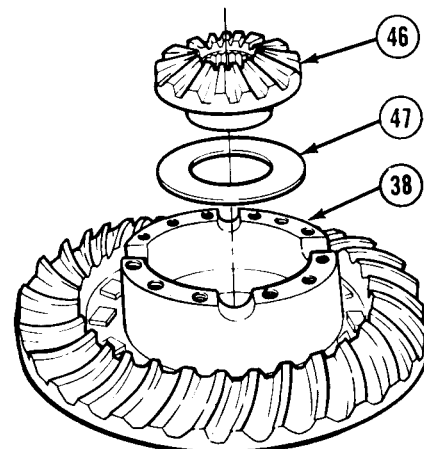

TA355943

Axles No. 1 and No. 2 Maintenance Instructions (Cont)

(37) Remove bearing cone (48) from differential case flanged half (38).

WARNING

Keep hands out from under ring gear. Do not allow ring gear to drop. Ring gear is heavy and can cause injury if dropped on hands.

(38) Remove 16 nuts (49) and screws (50).

(39) Remove ring gear (17) from differential case flanged half (38).

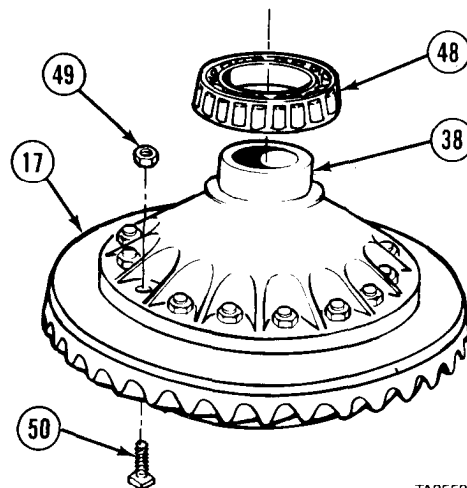

TA355944

NOTE

- It may be necessary to remove bearing cage assembly with pinion gear and press pinion from pinion gear.
- Support bearing and bearing race are provided as a set. Replace bearing race (para 9-9) whenever support bearing is replaced.

(40) Remove locknut (19), pinion gear (51) and support bearing (52) from pinion (53).

(41) Remove six screws (54) and lockwashers (55).

(42) Remove bearing cage (56) and attached parts from differential carrier (3).

(43) Remove shims (57) from differential carrier (3) and bearing cage (56). Record number and thickness of shims.

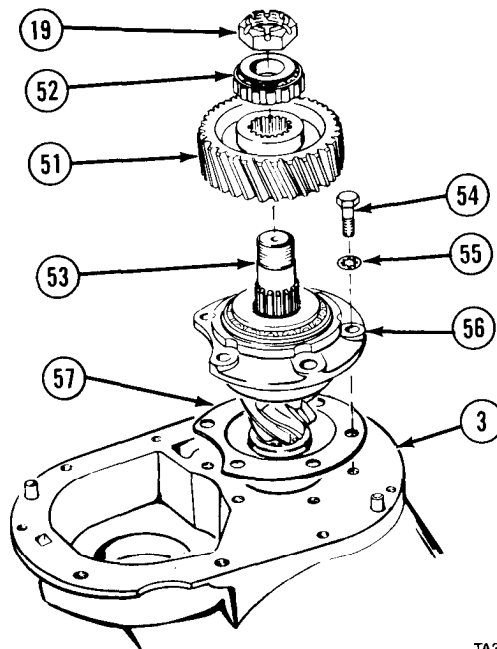

TA355946

Axles No. 1 and No. 2 Maintenance Instructions (Cont)

9-12. DIFFERENTIAL CARRIER, AXLE NO. 2 REPAIR (CONT).

(44) Press pinion (53) from bearing cage (56).

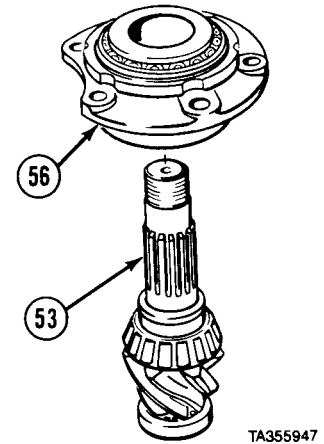

(45) Remove spacer (58) and spacer washer (59) from pinion (53).

(46) Remove inner bearing cone (60) and pilot bearing (61) from pinion (53).

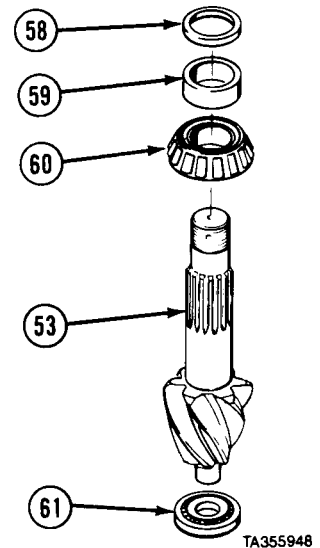

(47) Remove outer bearing cone (62) and bearing cups (63 and 64) from bearing cage (56).

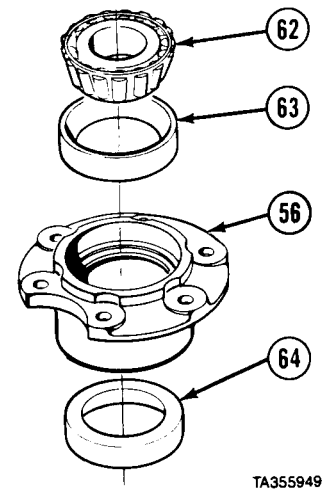

Axles No. 1 and No. 2 Maintenance Instructions (Cont)

- (48) Remove filler plug (65) from differential carrier (3).
- (49) Remove two screws (66), lockwashers (67), and cover (68).
- (50) Remove two expansion plugs (69).

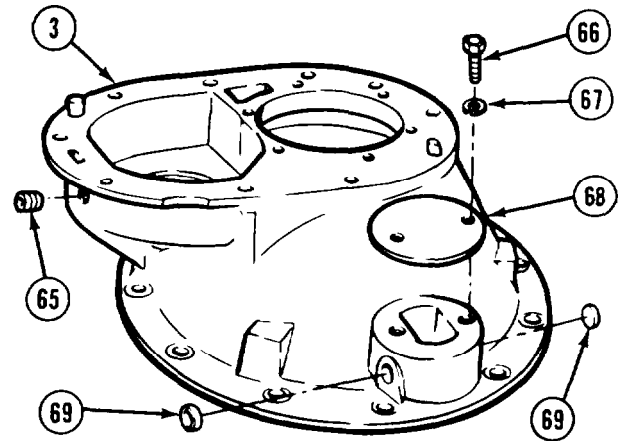
**b. Cleaning/Inspection.****WARNING**

Adhesives, solvents, and sealing compounds can burn easily, can give off harmful vapors, and are harmful to skin and clothing. To avoid injury or death, keep away from open fire and use in well-ventilated area. If adhesive, solvent, or sealing compound gets on skin or clothing, wash immediately with soap and water.

NOTE

If differential carrier housing must be replaced, the new housing will come as part of a kit. This kit will contain parts not required in this application. Refer to TM 9-2320-279-24P for proper identification of parts.

- (1) Clean all metal parts with drycleaning solvent.

WARNING

Compressed air used for cleaning purposes will not exceed 30 psi (207 kPa). Use only with effective chip guarding and personal protective equipment, goggles, shield, and gloves.

- (2) Use clean, lint-free cloth or compressed air to dry all metal parts, except bearings.
- (3) Allow bearings to air dry.
- (4) Scrape old sealant from carrier.
- (5) Inspect all metal parts for breaks, cracks, and sharp edges.
- (6) Inspect machined parts for nicks and burrs.

NOTE

If support bearing is bad, replace support bearing race (para 9-9).

- (7) Inspect bearings for loose rollers and cracked or broken races.
- (8) Coat bearings with lubricating oil.
- (9) Replace differential and output shaft bushings.
- (10) If pinion or ring gear is bad, replace both as a matched set.
- (11) Inspect dowel pins for breaks or cracks. Replace if damaged.

Axles No. 1 and No. 2 Maintenance Instructions (Cont)

9-12. DIFFERENTIAL CARRIER, AXLE NO. 2 REPAIR (CONT).

c. Assembly.

(1) Install bearing cone (1) on differential case flanged half (2).

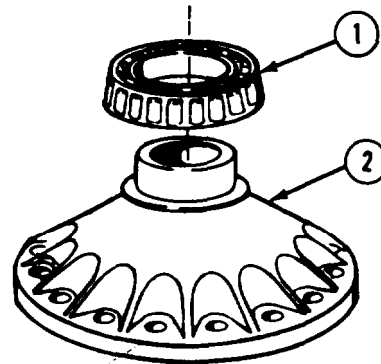

TA355951

(2) Install bearing cone (3) on differential case plain half (4).

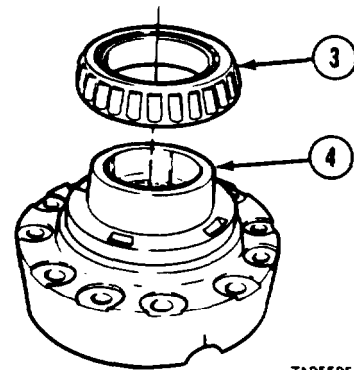

TA355952

(3) Install thrust washer (5) and side gear (6) in differential case flanged half (2).

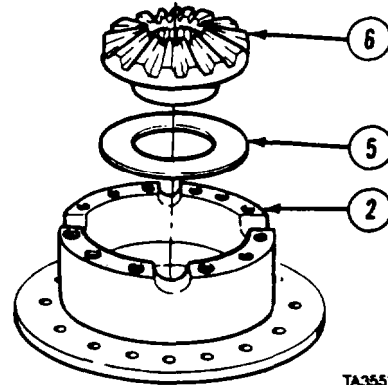

TA355953

(4) Lubricate spider (7) and install four side pinions (8) and thrust washers (9) on spider.

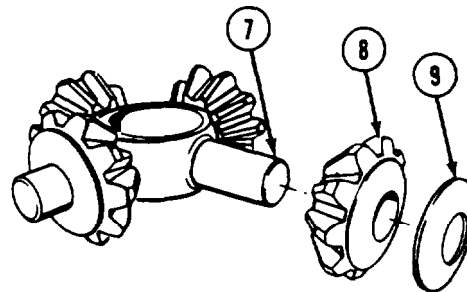

TA355954

Axles No. 1 and No. 2 Maintenance Instructions (Cont)

- (5) Install spider (7) and assembled parts in differential case flanged half (2).
- (6) Turn side pinions (8) and make sure that side pinions move freely.
- (7) Install side gear (10) and thrust washer (11) on top of four side pinions (8).

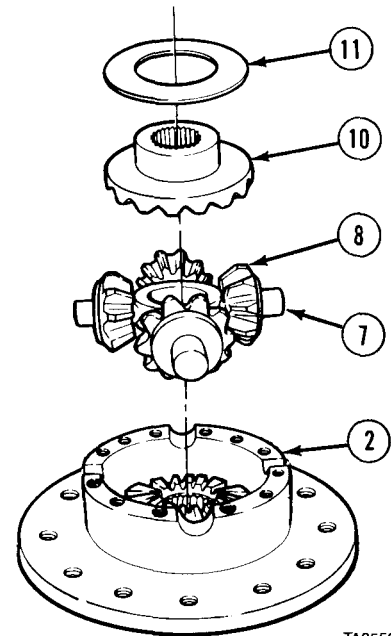

TA355956

- (8) Aline matchmarks and install differential case plain half (4) on differential case flanged half (2).

WARNING

Adhesives, solvents, and sealing compounds can burn easily, can give off harmful vapors, and are harmful to skin and clothing. To avoid injury or death, keep away from open fire and use in well-ventilated area. If adhesive, solvent, or sealing compound gets on skin or clothing, wash immediately with soap and water.

NOTE

Hub side gear should be hard to turn, but should turn smoothly with no binding or sticking.

- (9) Apply sealing and thread locking compound and install 12 screws (12) in differential case plain half (4). Tighten screws equally to 165 to 195 lb-ft (224 to 264 N·m).

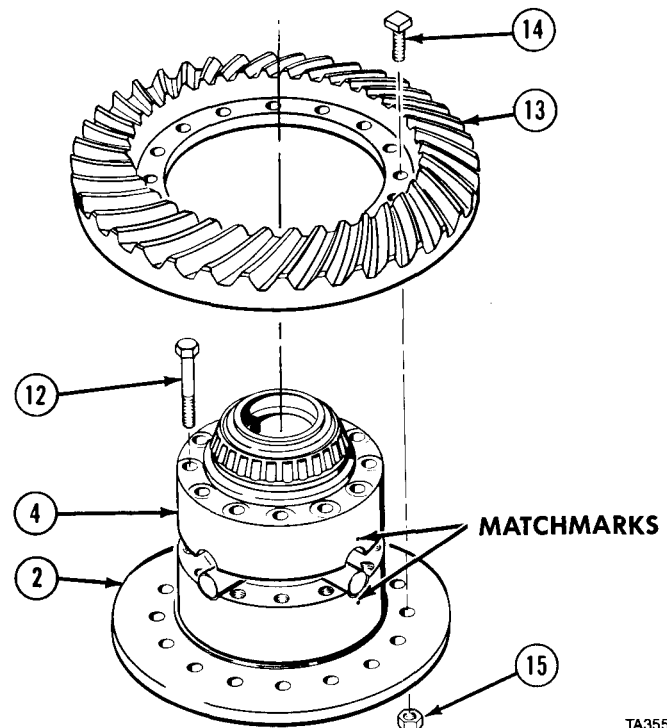

TA355957

CAUTION

Square head of screw must be seated in machined groove of ring gear, otherwise ring gear or screws may be damaged.

- (10) Install ring gear (13) on differential case flanged half (2) with 16 screws (14) and nuts (15). Tighten nuts to 180 to 220 lb-ft (244 to 298 N·m).

Axles No. 1 and No. 2 Maintenance Instructions (Cont)

9-12. DIFFERENTIAL CARRIER, AXLE NO. 2 REPAIR (CONT).

- (11) Install filler plug (16) in differential carrier (17).
- (12) Install two expansion plugs (18).
- (13) Apply adhesive-sealant to cover (19) and install with two lockwashers (20) and screws (21).
- (14) Tighten screws (21) to 35 to 45 lb-ft (47 to 61 N·m).

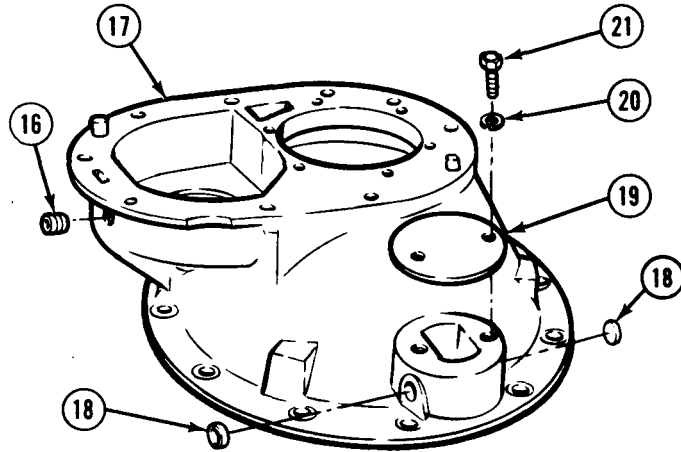

TA355958

- (15) Install inner bearing cup (22) in bearing cage (23).
- (16) Turn bearing cage (23) over.

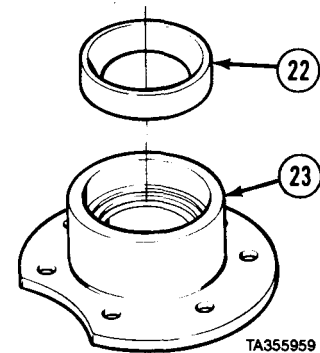

TA355959

- (17) Install outer bearing cup (24) in bearing cage (23).
- (18) Lubricate and install inner bearing cone (25).

NOTE

Use 0.185-in. (4.7 mm) spacer in step (19).

- (19) Install spacer washer (26) and spacer (27) in bearing cage (23).
- (20) Lubricate and install outer bearing cone (28).

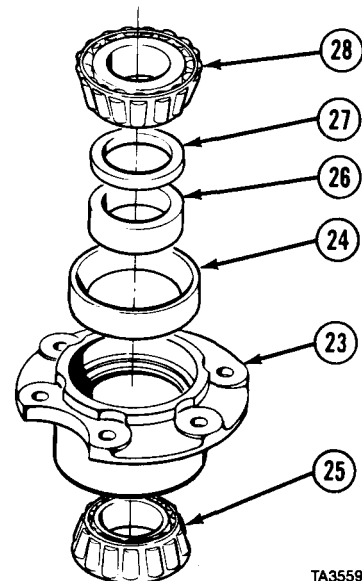

TA355960

Axles No. 1 and No. 2 Maintenance Instructions (Cont)

(21) Place bearing cage (23) and assembled parts in press so outer bearing cone (28) is on top.

CAUTION

- Turn bearing cage back and forth while applying pressure to be sure bearings and bearing cups are well lubricated.
- If bearing cage becomes hard to turn while applying pressure, **STOP!** Bearings can be damaged if too much pressure is applied. Get next larger spacer and repeat step (22).

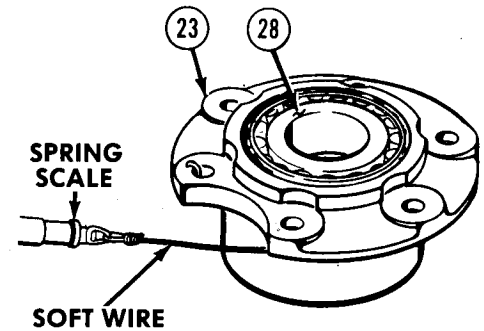

(22) Lower press ram for load of 18.0 to 20.0 tons (16.3 to 18.2 metric tons).

(23) Wrap soft wire around bearing cage (23) two times and fasten one end of wire in bearing cage screw hole. Fasten other end of wire to spring scale.

(24) Pull on spring scale until bearing cage (23) begins to turn. Check that spring scale reads 3 to 7 lb (1.3 to 3.2 kg). If spring scale reading is correct, go to step (30). If reading is too low, go to step (28). If reading is too high, continue with step (25).

(25) Remove outer bearing cone (28) and spacer (27) from bearing cage (23).

(26) Use 0.001-in. (0.025 mm) thicker spacer (27), and install spacer and outer bearing cone (28) in bearing cage (23).

(27) Repeat steps (21) through (24).

(28) Remove outer bearing cone (28) and spacer (27). Use 0.001-in. (0.025 mm) thinner spacer (27) and install spacer and outer bearing cone in bearing cage (23).

(29) Repeat steps (21) through (24).

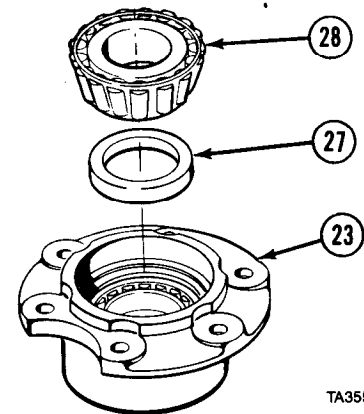

(30) Remove outer bearing cone (28), spacer (27), spacer washer (26), and inner bearing cone (25) from bearing cage (23).

(31) Get spacer (27) 0.001-in. (0.025 mm) thicker than last spacer used and set aside.

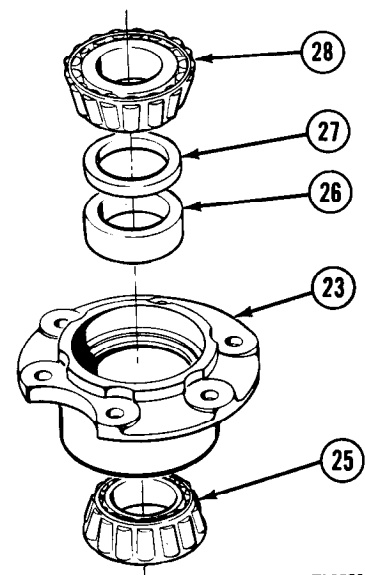

Axles No. 1 and No. 2 Maintenance Instructions (Cont)

9-12. DIFFERENTIAL CARRIER, AXLE NO. 2 REPAIR (CONT).

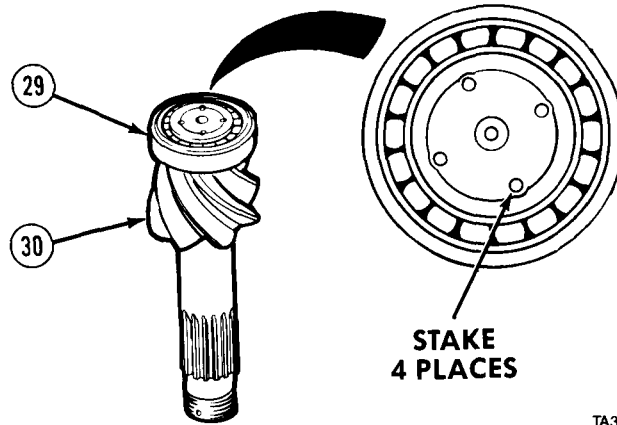

TA355964

- (32) Install pilot bearing (29) on pinion (30).
- (33) Stake pilot bearing (29) and pinion (30) as shown in pattern.

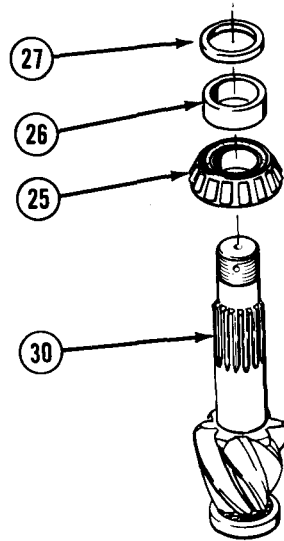

TA355965

- (34) Lubricate and install inner bearing cone (25) on pinion (30).
- (35) Install spacer washer (26) and spacer (27) on pinion (30).

Axles No. 1 and No. 2 Maintenance Instructions (Cont)

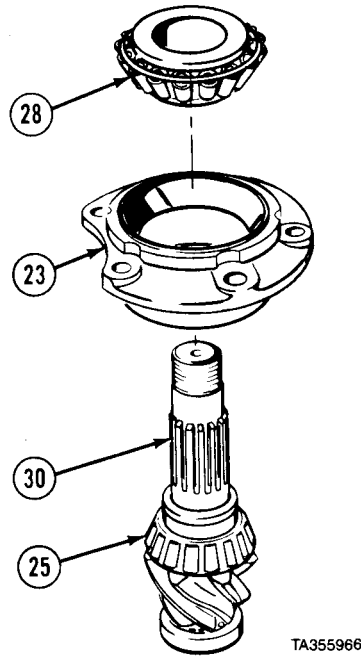

TA355966

- (36) Lubricate inner bearing cone (25) and install bearing cage (23) on pinion (30).
- (37) Lubricate and install outer bearing cone (28) on pinion (30).

NOTE

- To change spacer, remove pinion from bearing cage and outer bearing from pinion.
 - Turn bearing cage back and forth while applying pressure to be sure bearings are well lubricated.
- (38) Install pinion gear (31) on pinion (30). Position pinion in press and apply 1 to 2 tons (0.9 to 1.8 metric tons) load to pinion gear.
- (39) Turn bearing cage (23) by hand to make sure bearings are not binding. If bearings are binding, release pressure, then reapply pressure.

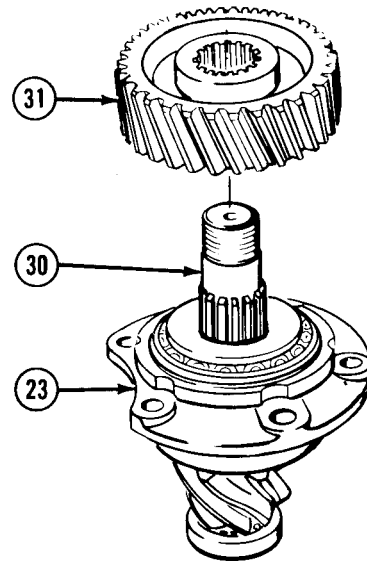

TA355967

Axles No. 1 and No. 2 Maintenance Instructions (Cont)

9-12. DIFFERENTIAL CARRIER, AXLE NO. 2 REPAIR (CONT).

- (40) Lower press ram for load of 18 to 20 tons (16.3 to 18.2 metric tons).
- (41) Measure pinion bearing preload. Wrap soft wire around bearing cage (23) twice and fasten one end of wire in bearing cage screw hole. Fasten other end of wire to spring scale.
- (42) Pull on spring scale until bearing cage (23) begins to turn. Check that spring scale reads 5 to 12 lb (2.3 to 5.5 kg). If spring scale reading is correct, go to step (49). If reading is too low, go to step (46). If reading is too high, continue with step (43).

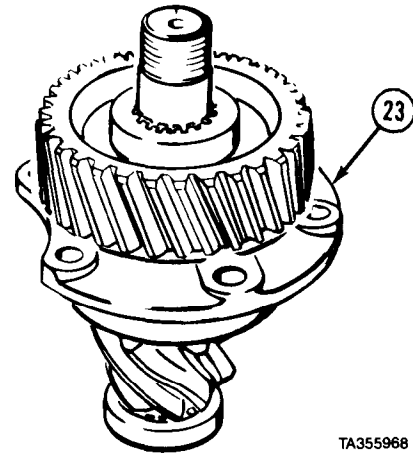

TA355968

- (43) Remove pinion (30) from bearing cage (23), pinion gear (31), and outer bearing cone (28).
- (44) Use 0.001-in. (0.025 mm) thicker spacer (27) and install bearing cage (23), spacer (27), and outer bearing cone (28) on pinion (30).
- (45) Repeat steps (38) through (42).
- (46) Remove pinion (30) from bearing cage (23), pinion gear (31), and outer bearing cone (28).
- (47) Use 0.001-in. (0.025 mm) thinner spacer (27) and install bearing cage (23), spacer (27), and outer bearing cone (28) on pinion (30).
- (48) Repeat steps (38) through (42).
- (49) Remove pinion gear (31) from pinion (30).

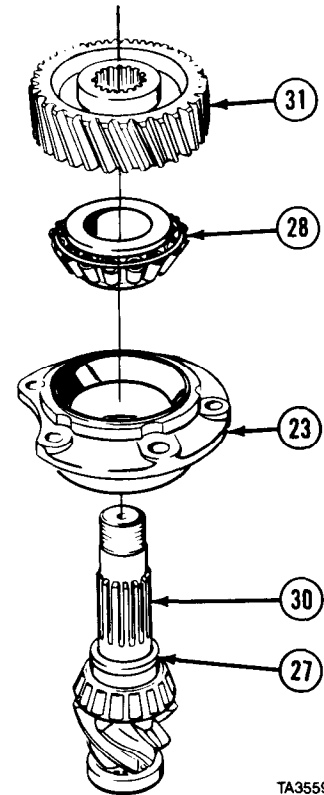

TA355969

Axles No. 1 and No. 2 Maintenance Instructions (Cont)

- (50) Install same number and size of shims (32) recorded in disassembly step (42).

WARNING

Adhesives, solvents, and sealing compounds can burn easily, can give off harmful vapors, and are harmful to skin and clothing. To avoid injury or death, keep away from open fire and use in well-ventilated area. If adhesive, solvent, or sealing compound gets on skin or clothing, wash immediately with soap and water.

- (51) Apply sealing compound to flange of bearing cage (23).
- (52) Install bearing cage (23) on differential carrier (17).

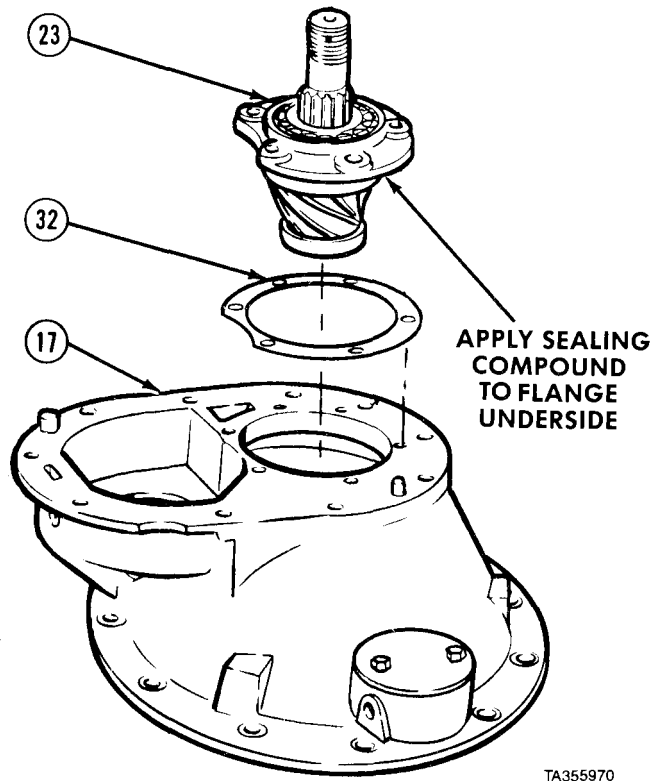

- (53) Apply thread locking compound to threads of six screws (33) and install screws and six lockwashers (34). Tighten screws to 155 to 175 lb-ft (210 to 237 N·m).
- (54) Coat outside diameter of bearing cage (23) with sealing compound.

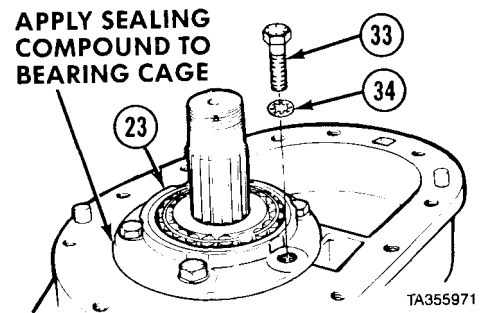

- (55) Install bearing cup (35) in bearing adjuster (36).

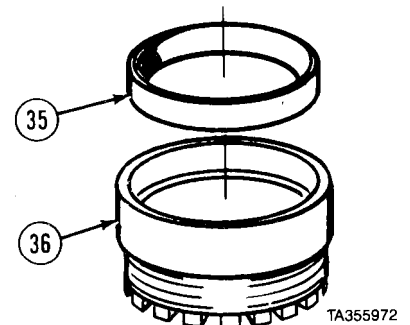

Axles No. 1 and No. 2 Maintenance Instructions (Cont)

9-12. DIFFERENTIAL CARRIER, AXLE NO. 2 REPAIR (CONT).

(56) Install two bushings (37) in differential carrier (17).

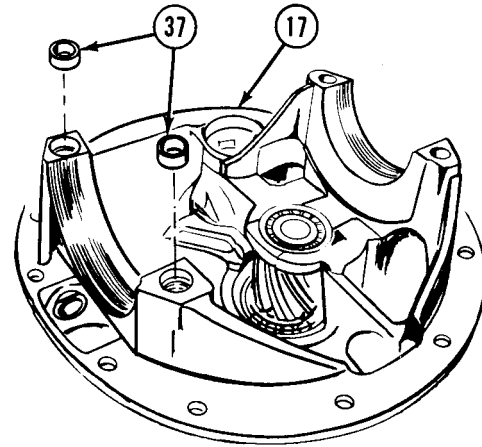

TA355973

(57) Attach suitable lifting device to assembled ring gear and differential (38).

(58) Lubricate bearing cones (1 and 3) with oil and position bearing cup (39) on bearing cone (3).

NOTE

Ring gear must be tilted to clear casting inside carrier.

(59) Soldier A installs assembled ring gear and differential (38) into differential carrier (17) while Soldier B operates lifting device.

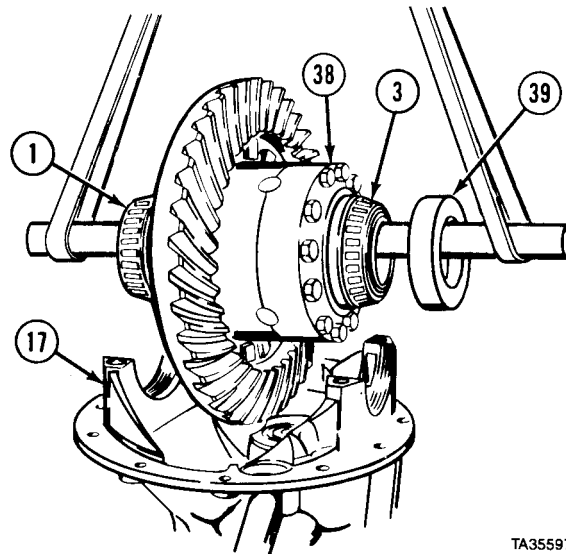

TA355974

CAUTION

Threads on bearing adjusters can be damaged if bearing adjusters are not installed carefully.

(60) Install bearing cap (40) with two screws (41) and washers (42). Tighten screws finger-tight.

(61) Install bearing cap (43) with two screws (44) and washers (45). Tighten screws finger-tight.

(62) Install bearing adjusters (36 and 46) finger-tight.

(63) Remove lifting device.

(64) Tighten four screws (41 and 44) to 40 to 50 lb-ft (54 to 68 N·m).

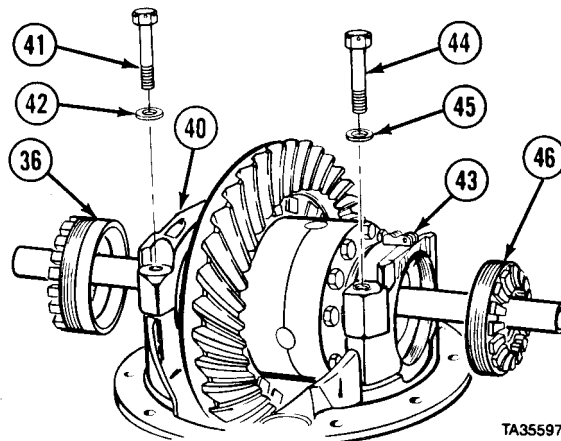

TA355975

Axles No. 1 and No. 2 Maintenance Instructions (Cont)

(65) Install pinion gear (31) on pinion (30).

NOTE

Support bearing and bearing race are provided as a set. Replace support bearing race (para 9-9) whenever support bearing is replaced.

(66) Install support bearing (47) and locknut (48). Tighten locknut to 980 lb-ft (1 329 N-m).

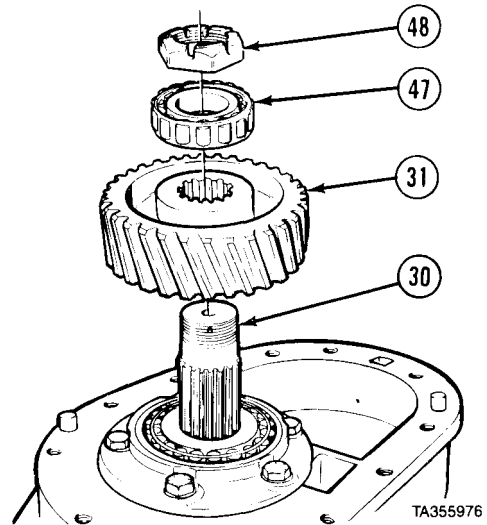

NOTE

Align notch in bearing adjusters with mark on bearing cap.

- (67) Tighten bearing adjuster (46) until one thread shows.
- (68) Tighten bearing adjuster (36) until ring gear (13) cannot be rocked back and forth toward two bearing adjusters and there is no backlash.
- (69) Rotate ring gear (13) and check for bind. If ring gear binds, loosen bearing adjuster (36) then tighten until ring gear does not bind.
- (70) Tighten bearing adjuster (46) until it contacts bearing cup or resists turning.
- (71) Tighten bearing adjuster (46) two or three more notches until ring gear (13) has backlash.

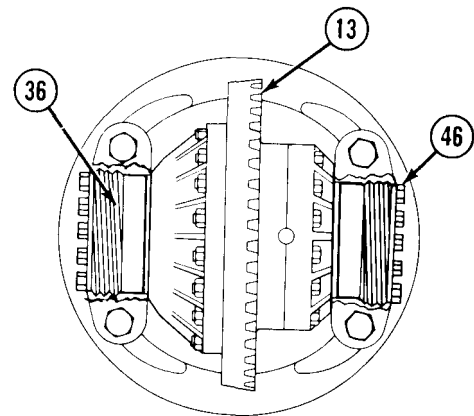

NOTE

If old pinion and ring gear are used, backlash should be the same as recorded in disassembly step (11). If new pinion and ring gear are used, backlash should be 0.008 to 0.018 in. (0.203 to 0.457 mm).

(72) Move ring gear (13) back and forth to measure backlash with dial indicator. If backlash is correct, go to step (81). If there is too much backlash, go to step (77). If there is not enough backlash, continue with step 3).

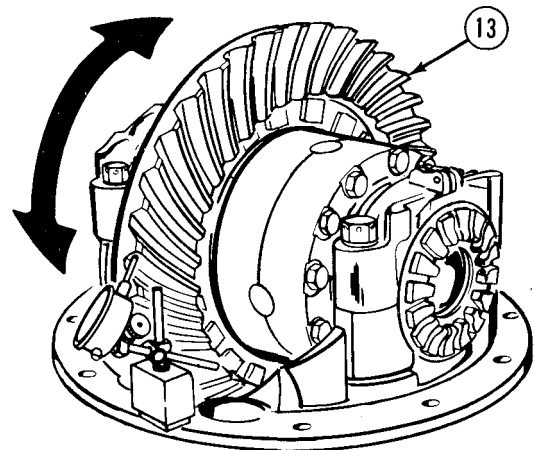

Axles No. 1 and No. 2 Maintenance Instructions (Cont)

9-12. DIFFERENTIAL CARRIER, AXLE NO. 2 REPAIR (CONT).

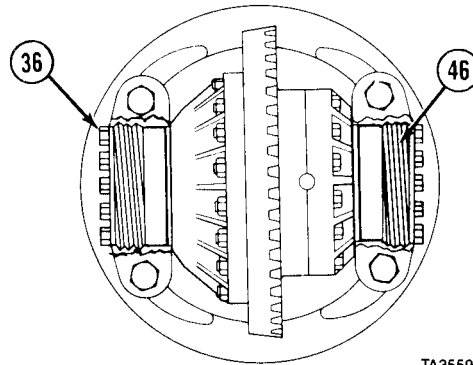

- (73) To add backlash, loosen bearing adjuster (46) five or six notches.
- (74) Loosen bearing adjuster (36) one notch.
- (75) Tighten bearing adjuster (46) until bearing adjuster resists movement, then tighten two or three more notches.
- (76) Repeat step (72).
- (77) To remove backlash, loosen bearing adjuster (46) five or six notches.
- (78) Tighten bearing adjuster (36) one notch.
- (79) Tighten bearing adjuster (46) until bearing adjuster resists movement, then tighten two or three more notches.
- (80) Repeat step (72).

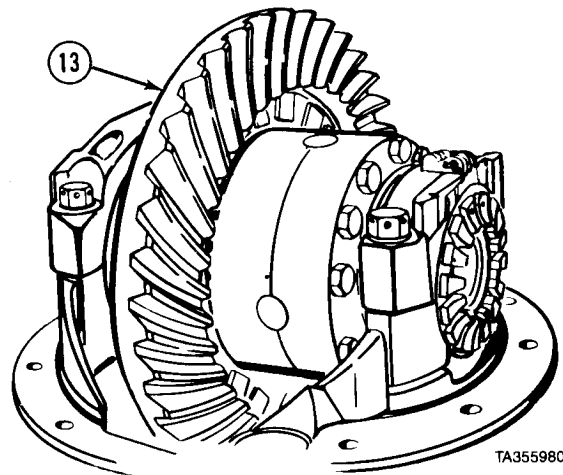

- (81) Paint one-third of teeth on ring gear (13) with prussian blue dye.
- (82) Roll ring gear (13) one-third turn, then rock ring gear forward and backward to set pattern in dye.

Axles No. 1 and No. 2 Maintenance Instructions (Cont)

CORRECT PATTERN (NEW GEARING)

- COULD VARY IN LENGTH. PATTERN SHOULD COVER 1/2 TOOTH OR MORE (FACE WIDTH).

- PATTERN SHOULD BE EVENLY CENTERED BETWEEN TOOTH TOP LAND AND ROOT.

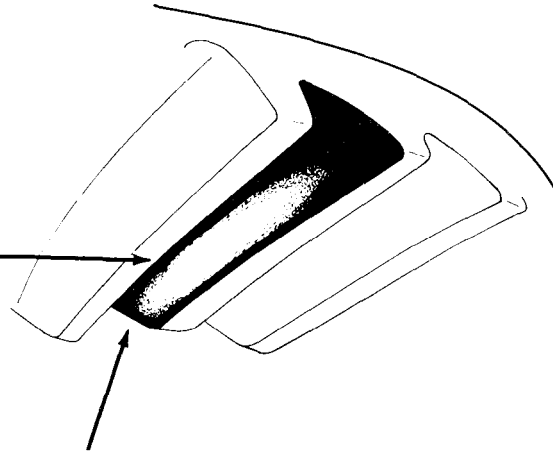

TA355981

- PATTERN SHOULD BE CLEAR OF TOOTH TOE.

PATTERN A

NOTE

- A correct gear pattern for a used pinion and ring gear is clear of the toe and centers evenly along the face of gear tooth, but can be any length and shape and is acceptable as long as pattern does not run off gear tooth at any point.
- If gear pattern was correct at disassembly, then gear pattern after assembly should be the same.
- If pattern is not the same, review steps (84) through (87) and adjust backlash as required until pattern that was recorded at disassembly is reached.
- If pattern was incorrect (pattern runs off gear tooth) at disassembly then, after assembly, review steps (84) through (87) and adjust backlash as required until correct gear pattern (pattern does not run off gear teeth) is reached.
- Remember, a correct gear pattern for a used pinion and ring gear does not have to match PATTERN A (correct pattern for new gearing).
- If new pinion and ring gear are used, tooth pattern should be like correct pattern A above. If tooth pattern does not look like A, check patterns B through E to find one that looks close to ring gear tooth pattern, then do step that follows incorrect pattern.

(83) If tooth contact is like pattern A, do not adjust. Go to step (88).

Axles No. 1 and No. 2 Maintenance Instructions (Cont)

19-12. DIFFERENTIAL CARRIER, AXLE NO. 2 REPAIR (CONT).

(84) If tooth contact is like pattern B, add backlash, steps (73) through (76). Repeat steps (81) through (83).

INCORRECT PATTERN

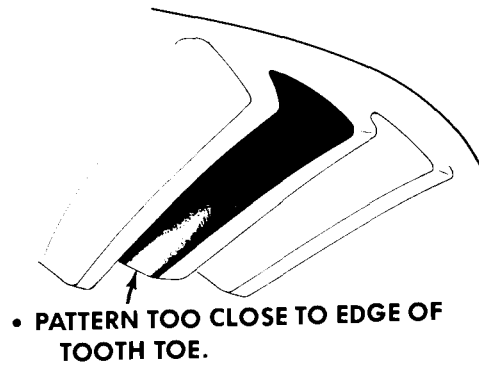

PATTERN B

TA355982

(85) If tooth contact pattern is like pattern C, remove backlash, steps (77) through (80). Repeat steps (81) through (83).

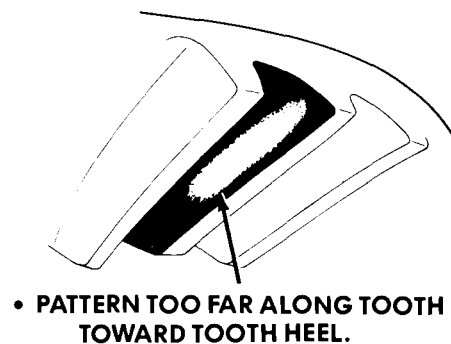

PATTERN C

TA355983

NOTE

To add or remove shims in steps (86) and (87) remove ring gear and differential assembly (steps (15) through (23) in Disassembly) and pinion (steps (39) through (42) in Disassembly). Add or remove shims, then install pinion, ring gear, and differential assembly (steps (51) through (66)).

(86) If tooth contact is like pattern D, move pinion closer to ring gear (13) by removing shims. Repeat steps (72) through (83).

INCORRECT PATTERN

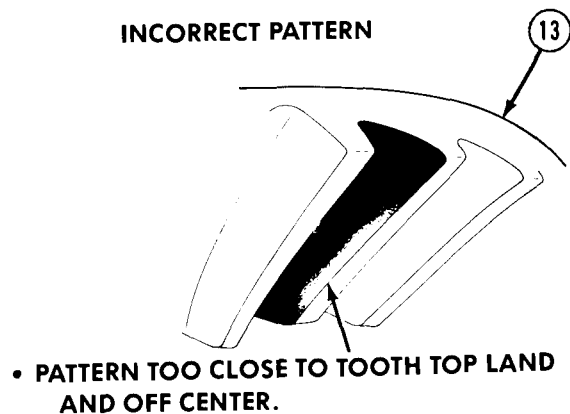

PATTERN D

TA355984

Axles No. 1 and No. 2 Maintenance Instructions (Cont)

(87) If tooth contact is like pattern E, move pinion away from ring gear (13) by adding shims. Repeat steps (72) through (83).

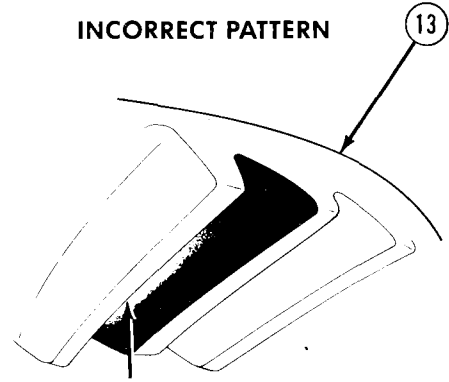

• PATTERN TOO CLOSE OR OFF TOOTH ROOT.

PATTERN E

TA355985

(88) Tighten four screws (41 and 44) to 370 to 430 lb-ft (502 to 583 N·m).

NOTE

Bearing adjuster may be turned slightly to aline adjuster locks.

(89) Install adjuster lock (49) and cotter pin (50) on bearing cap (43).

(90) Install lockwire on four screws (41 and 44).

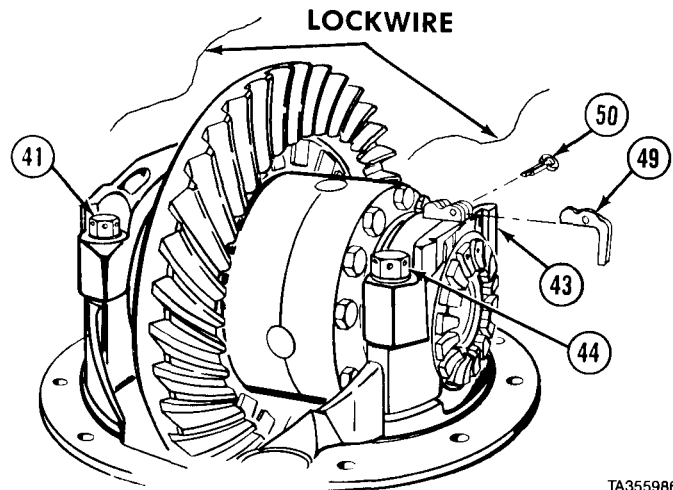

TA355986

(91) Install adjuster lock (51) with two screws (52).

(92) Install lockwire on two screws (52).

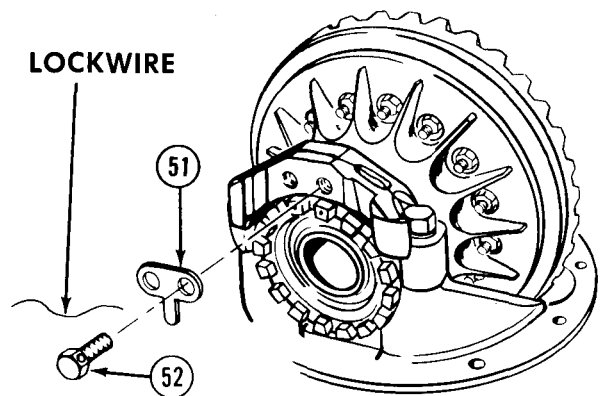

TA355987

Axles No. 1 and No. 2 Maintenance Instructions (Cont)

19-12. DIFFERENTIAL CARRIER, AXLE NO. 2 REPAIR (CONT).

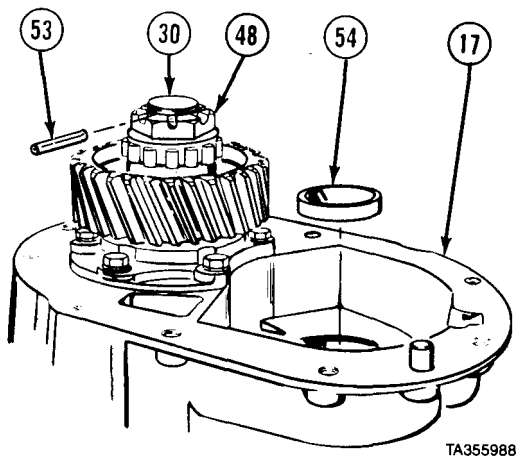

TA355988

NOTE

To install roll pin do not loosen locknut. Always tighten locknut to aline holes.

- (93) Install roll pin (53) through locknut (48) and pinion (30).
- (94) Install bearing cup (54) in differential carrier (17).

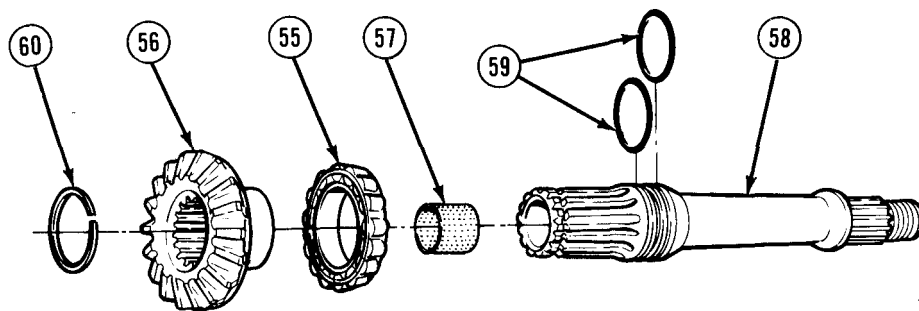

TA355989

- (95) Install bearing (55) on side gear (56).
- (96) Install bushing (57) in end of output shaft (58).
- (97) Apply lubricating oil to two preformed packings (59) and install on output shaft (58).
- (98) Install side gear (56) and assembled parts on output shaft (58).

WARNING

Wear safety glasses while installing retaining rings to protect eyes from possible injury or blindness.

- (99) Install retaining ring (60) on end of output shaft (58).

Axles No. 1 and No. 2 Maintenance Instructions (Cont)

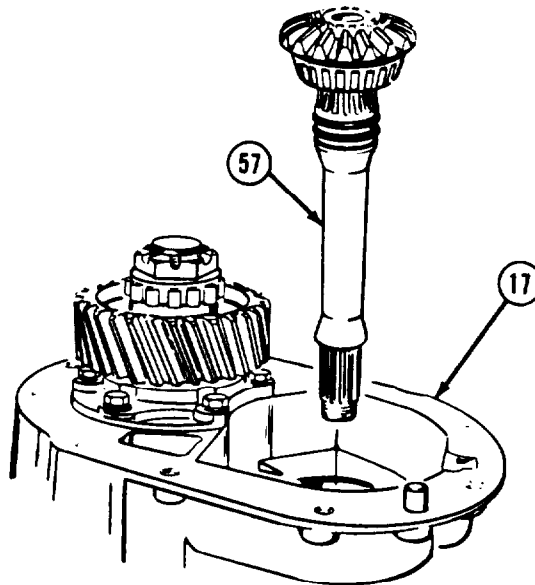

TA355990

(100) Install output shaft (58) and assembled parts in differential carrier (17).

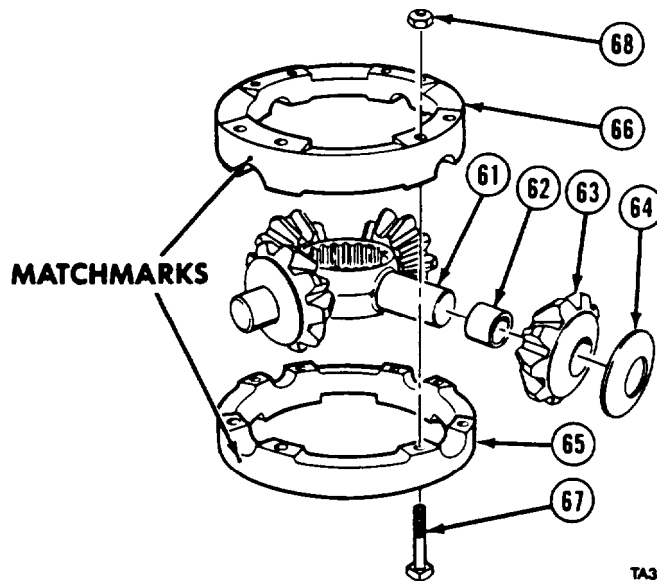

TA357283

- (101) Lubricate spider (61), four bushings (62), and side pinions (63) and install bushings, side pinions, and thrust washers (64) on spider.
- (102) Align matchmarks and install inter-axle differential case halves (65 and 66) on spider (61) with assembled parts.
- (103) Install eight screws (67) and locknuts (68) in two inter-axle differential case halves (65 and 66). Tighten locknuts to 17 to 23 lb-ft (23 to 31 N•m).

Axles No. 1 and No. 2 Maintenance Instructions (Cont)

9-12. DIFFERENTIAL CARRIER, AXLE NO. 2 REPAIR (CONT).

CAUTION

Inter-axle differential and output shaft are not secured in carrier and can fall out and be damaged if differential carrier is tipped over.

(104) Install assembled inter-axle differential (69) on side gear (56) so eight locknuts (68) face outward.

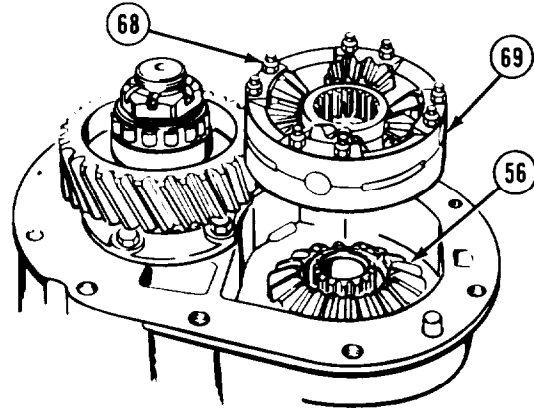

d. **Follow-on Maintenance.** None

END OF TASK

Section IV. BALL SOCKET

9-13. BALL SOCKET REMOVAL/INSTALLATION.

This task covers:

- a. Removal
- b. Cleaning/Inspection
- c. Installation
- d. Follow-on Maintenance

INITIAL SETUP

Models
All

Test Equipment
Scale, spring

Special Tools
None

Supplies
Grease, automotive and artillery, Item 34, Appendix C
Adhesive, Item 2.1, Appendix C
Adhesive-sealant, silicone, Item 6, Appendix C
Tags, identification, Item 60, Appendix C
Solvent, drycleaning, Item 57, Appendix C

Personnel Required
MOS 63W, Wheel vehicle repairer

References
None

Equipment Condition

<i>TM or Para</i>	<i>Condition Description</i>
TM 9-2320-279-10	Wheel and tire assembly removed.
LO 9-2320-279-12	Axle drained.
TM 9-2320-279-20	Brake chamber removed.
TM 9-2320-279-20	Slack adjuster and camshaft removed.
TM 9-2320-279-20	Steering arm removed.
TM 9-2320-279-20	Tie rod removed.
Para 9-2	Axle shaft assembly removed.

Special Environmental Conditions
None

General Safety Instructions
None

Level of Maintenance
Direct Support

Axles No. 1 and No. 2 Maintenance Instructions (Cont)

a. Removal.

- (1) Record number and thickness of shims (1) and remove shims from studs (2) on left-hand ball socket (3).

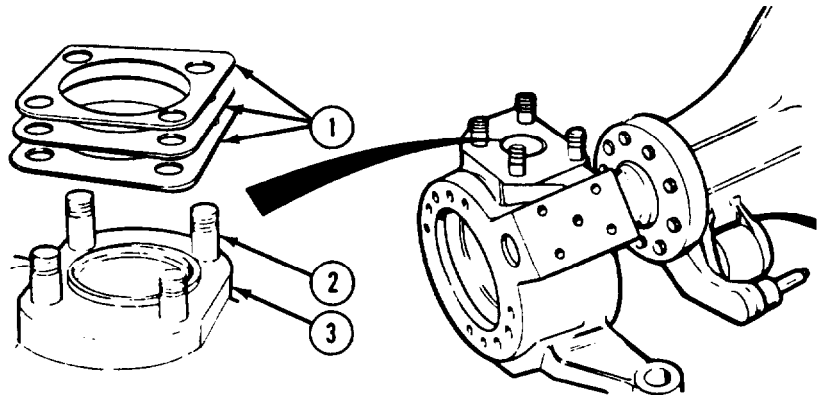

TA191142

NOTE

Steps (2) and (3) are for both left and right sides.

- (2) Remove pipe plug (4).
- (3) Remove four screws (5), lockwashers (6), bottom cover (7), and shims (8) from ball socket (3). Record number and thickness of shims.

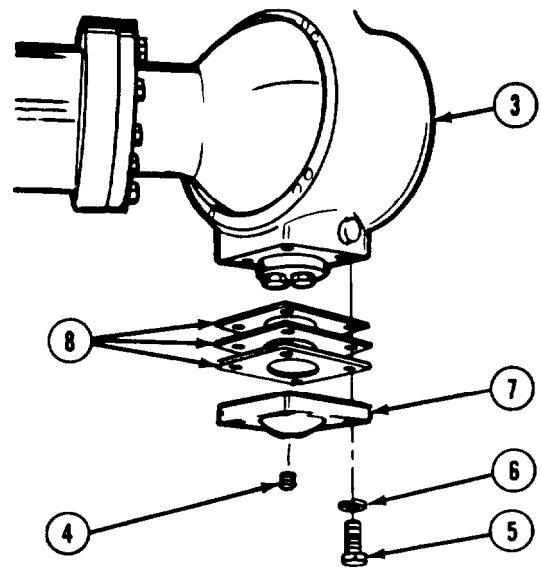

TA191143

NOTE

Steps (4) through (6) are for right side only.

- (4) Remove grease fitting (9).
- (5) Remove four screws (10), lockwashers (11), and top cover (12).
- (6) Record number and thickness of shims (13) and remove shims.

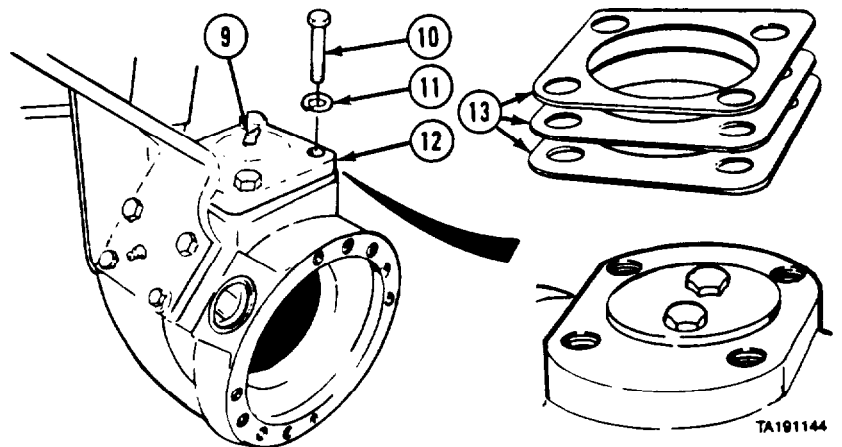

TA191144

Axles No. 1 and No. 2 Maintenance Instructions (Cont)

9-13. BALL SOCKET REMOVAL/INSTALLATION (CONT).

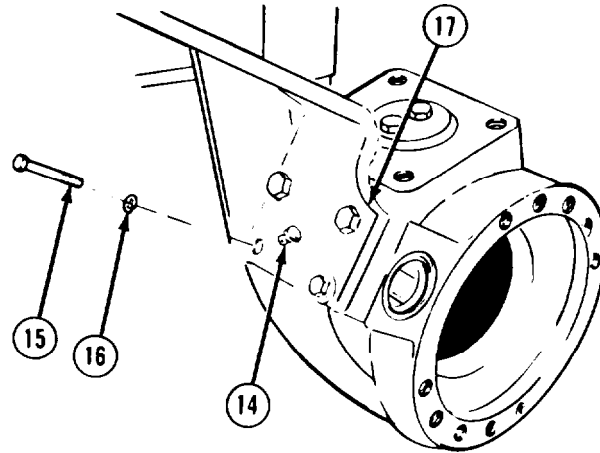

NOTE

Steps (7) through (13) are for both left and right sides.

- (7) Remove grease fitting (14).
- (8) Remove four screws (15) and lockwashers (16).
- (9) Remove brake chamber mounting bracket (17).

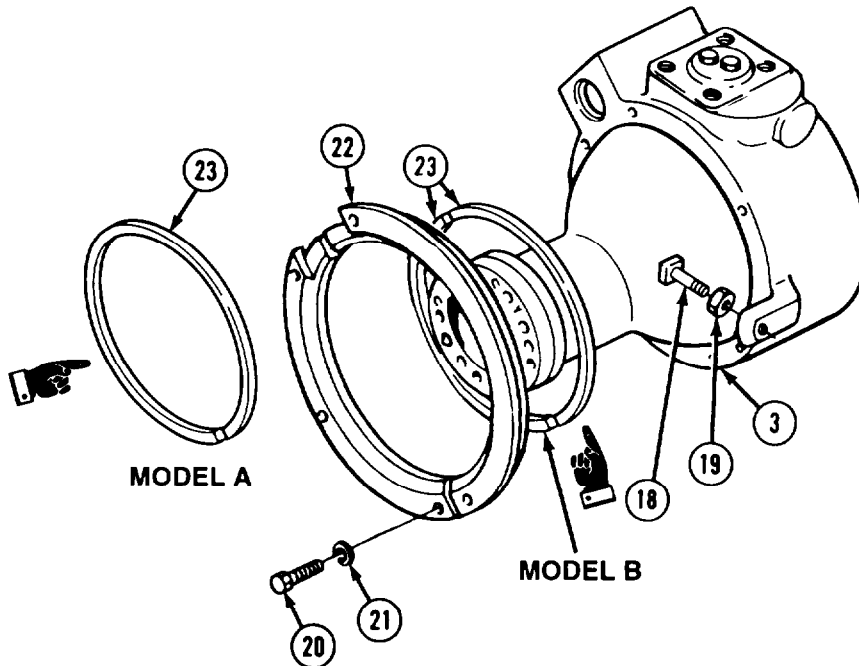

- (10) Measure and record length from top of stop bolt (18) to top of nut (19).
- (11) Remove nut (19) and stop bolt (18) from ball socket (3).
- (12) Remove six screws (20) and lockwashers (21).

NOTE

Seal halves are glued together and may be one piece on Model A or two pieces on Model B.

- (13) Remove seal retainer (22) and seal (23).

Axles No. 1 and No. 2 Maintenance Instructions (Cont)

NOTE

Step (14) is for left side only.

- (14) Remove two screws (24) and end plate (25).

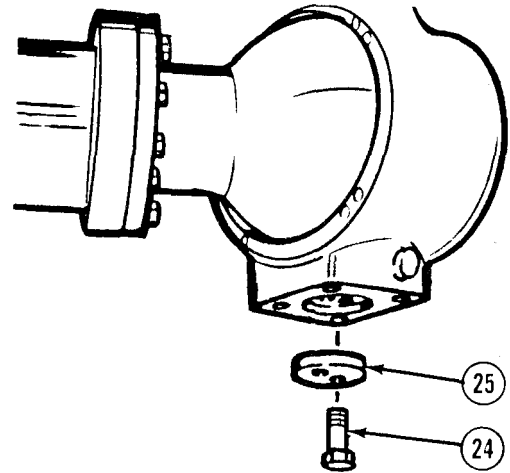

TA191148

NOTE

Steps (15) through (21) are for both left and right sides.

- (15) Remove lower axle ball trunnion (26) by driving lower axle ball trunnion upward into ball and bushing assembly (27).

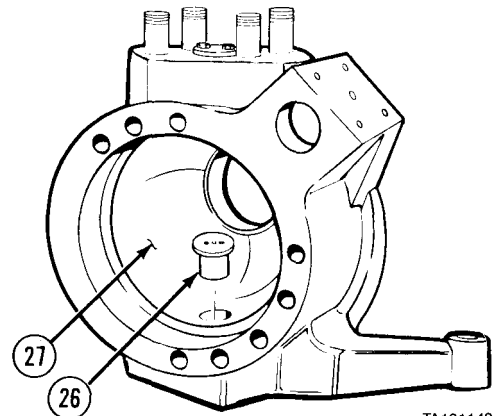

TA191149

- (16) Remove two screws (28) and end plate (29) from upper axle ball trunnion (30).
- (17) Remove upper axle ball trunnion (30) by driving upper axle ball trunnion downward into ball and bushing assembly (27).

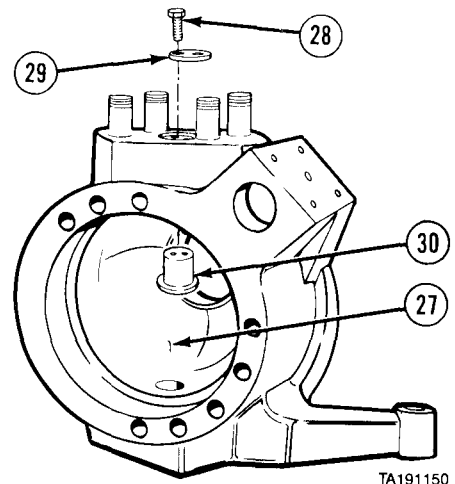

TA191150

Axles No. 1 and No. 2 Maintenance Instructions (Cont)

9-13. BALL SOCKET REMOVAL/INSTALLATION (CONT.)

CAUTION

Use sledge hammer carefully. Hammering too hard can crack ball socket or damage trunnion bearings if they are not seated while hammering.

(18) Hammer around top of ball socket (3) until upper and lower bearing cups (31 and 32) are 1/8 in. (3.18 mm) above and below ball socket surface.

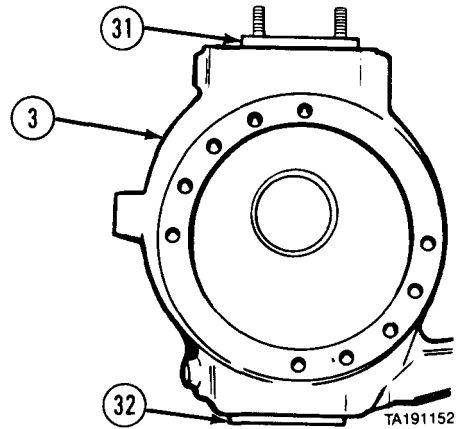

(19) Tip ball socket (3) out and up from bottom and remove from ball and bushing assembly (27).

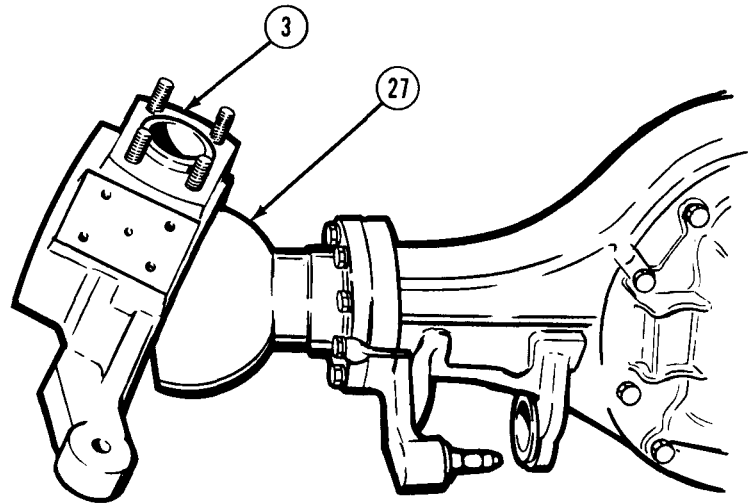

NOTE

Upper and lower bearings and bearing cups are matched sets. Tag and mark bearings and bearing cups.

(20) Remove bearings (33 and 34).

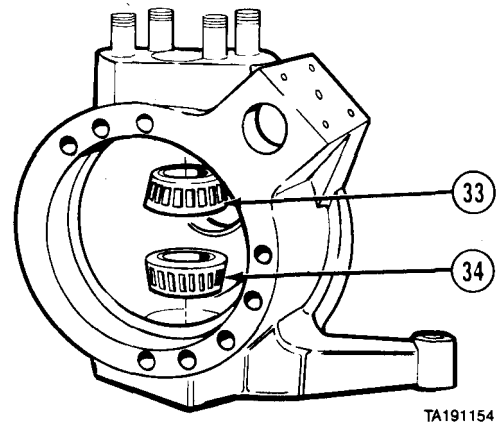

Axles No. 1 and No. 2 Maintenance Instructions (Cont)

- (21) Remove upper and lower bearing cups (31 and 32) from ball socket (3).
- (22) Remove four studs (35) from ball socket (3) on left side only.
- (23) Remove two seals (36) and bushings (37) on right and left side.

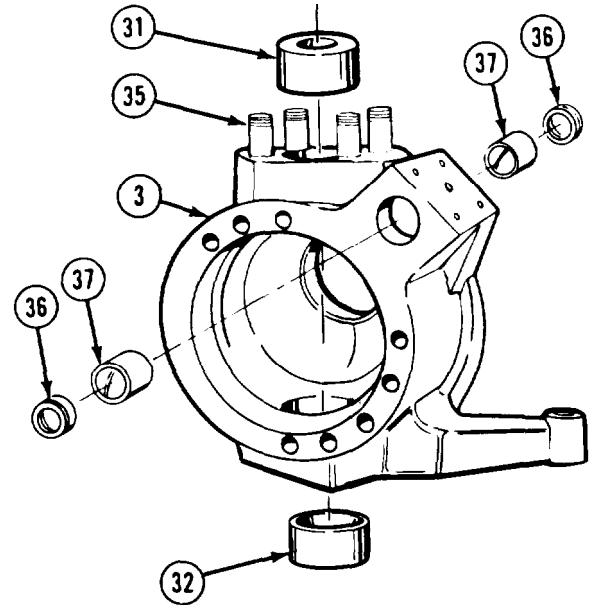

b. Cleaning/Inspection.

WARNING

Adhesives, solvents, and sealing compounds can burn easily, can give off harmful vapors, and are harmful to skin and clothing. To avoid injury or death, keep away from open fire and use in well-ventilated area. If adhesive, solvent, or sealing compound gets on skin or clothing, wash immediately with soap and water.

- (1) Clean all metal parts with drycleaning solvent.
- (2) Inspect ball socket for cracks and breaks. Replace if damaged.
- (3) Inspect bearing cups for gouges. If gouged, replace bearing cups and bearings.
- (4) Inspect bearings for loose rollers and cracked or broken races. Replace if damaged.
- (5) Inspect seals for tears. Replace torn seals.
- (6) Inspect bushings for gouges and out-of-round condition. If bushing is gouged or more than 0.050 in. (1.270 mm) out-of-round, replace.
- (7) Inspect axle ball trunnions for breaks or gouges. Replace if damaged.
- (8) Inspect studs for damaged threads and cracks or breaks. Replace if damaged.

c. Installation

NOTE

- Steps (1) through (16) are for both left and right ball sockets. Left ball socket is shown.
- Top bearing cup has small opening up and bottom bearing cup has small opening down.

- (1) Install bearing cups (1 and 2) in ball socket (3). Tap bearing cups down until bearing cups are not more than 1/8 in. (3.18 mm) above ball socket.

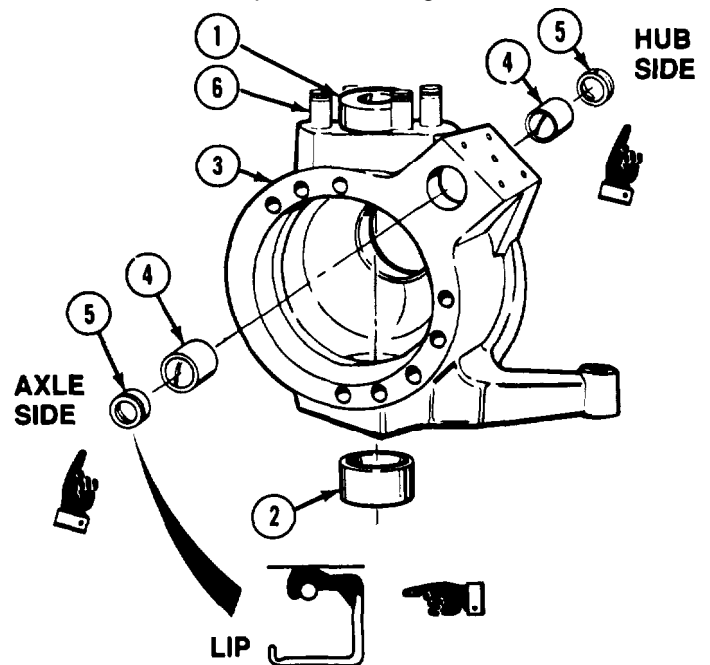

CAUTION

Lip of seal (hub side) must face toward bushing to prevent grease from entering brake area. Lip of seal (axle side) must face away from bushing to allow grease to exit socket.

- (2) Install two bushings (4) and seals (5) in ball socket (3).
- (3) Install four studs (6) in left ball socket (3).

Axles No. 1 and No. 2 Maintenance Instructions (Cont)

9-13. BALL SOCKET REMOVAL/INSTALLATION (CONT).

NOTE

Pack bearings with grease.

- (4) Install lower bearing (7) in bearing cup (2).
- (5) Install upper bearing (8) in bearing cup (1).

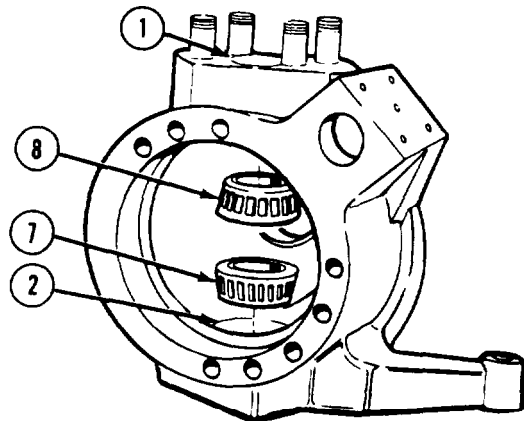

TA191158

- (6) With brake air chamber mounting surface (9) facing to the rear and mounting holes (10) facing outward, install ball socket (3) over ball and bushing assembly (11).

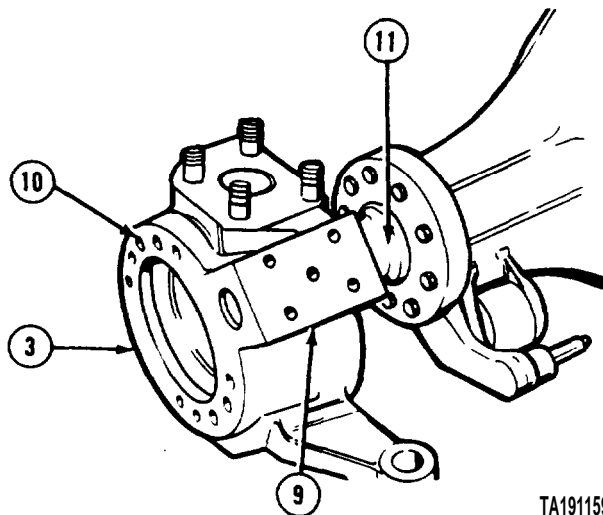

TA191159

- (7) Align ball socket (3) with trunnion holes in ball and bushing assembly (11). Install axle ball trunnions (12 and 13).
- (8) Drive bearing cups (1 and 2) flush with surface of ball and bushing assembly (11).

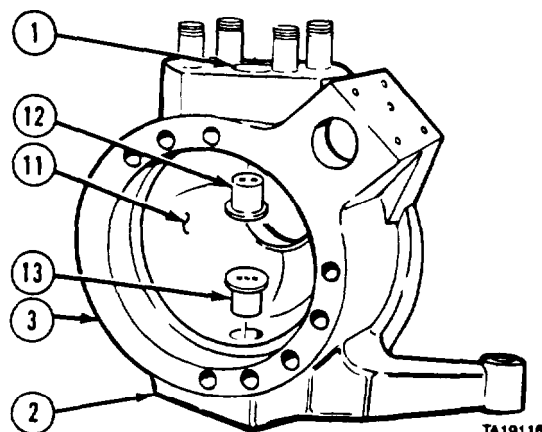

TA191160

Axles No. 1 and No. 2 Maintenance Instructions (Cont)

NOTE

Steps (9) and (10) are for left side only.

- (9) Apply light coat of grease to threads of two screws (14).
- (10) Install end plate (15) and two screws (14) on lower axle ball trunnion (13). Tighten screws to 40 lb-ft (54 N·m).

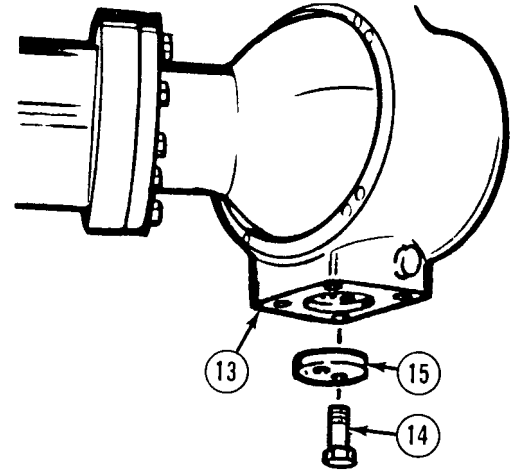

TA191161

NOTE

Install same number and thickness of shims as removed.

- (11) Install shims (16), bottom cover (17), four lockwashers (18), and screws (19).
- (12) Tighten screws (19) to 185 lb-ft (251 N·m).
- (13) Install grease fitting (20) in bottom cover (17).
- (14) Lubricate lower bearing at grease fitting (20) with grease.
- (15) Remove grease fitting (20).
- (16) Install pipe plug (21).
- (17) Apply grease to ball and bushing assembly (11) at rear of ball socket (3).

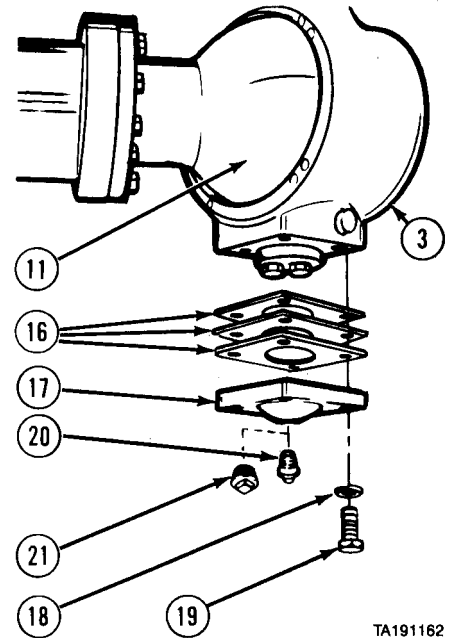

TA191162

Axles No. 1 and No. 2 Maintenance Instructions (Cont)

9-13. BALL SOCKET REMOVAL/INSTALLATION (CONT).

- (18) Install end plate (22) and two screws (23) on upper axle ball trunnion (12). Tighten screws to 40 lb-ft (54 N•m).

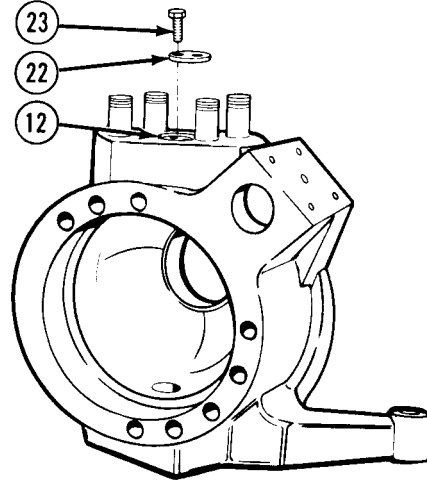

NOTE

- Steps (19) through (25) are for left ball socket only.
- Install same number and thickness of shims as removed.

- (19) Install shims (24) on four studs (6).

NOTE

Install steering arm with flange side down.

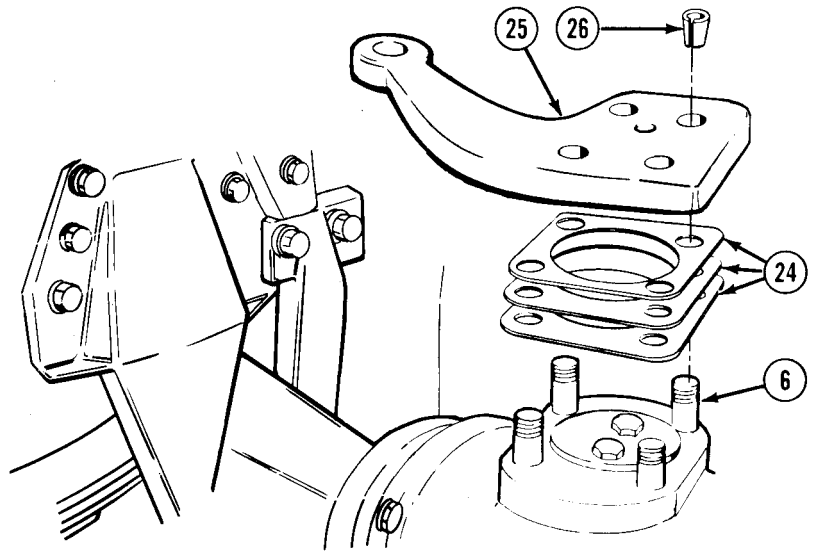

- (20) Install steering arm (25) on studs (6).
 (21) Install four dowel pins (26) in studs (6).

- (22) Secure steering arm (25) with four lockwashers (27) and nuts (28).
 (23) Tighten nuts (28) to 320 lb-ft (434 N•m).
 (24) Install grease fitting (29).
 (25) Lubricate upper bearing at grease fitting (29).

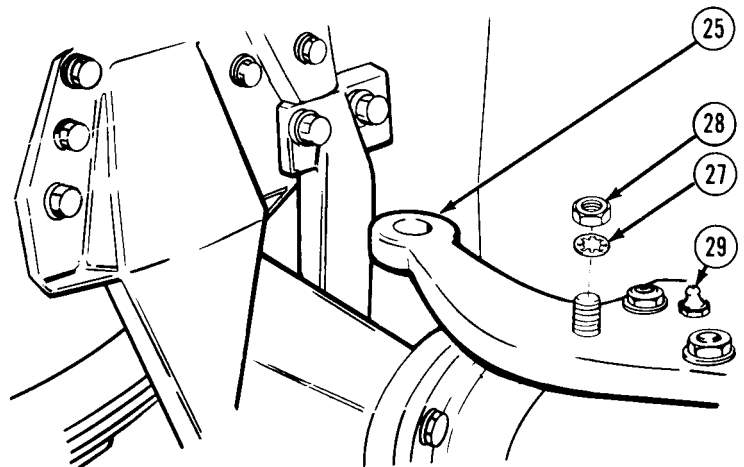

Axles No. 1 and No. 2 Maintenance Instructions (Cont)

NOTE

- Steps (26) through (28) are for right ball socket only.
 - Install same number and thickness of shims as removed.
- (26) Install shims (30), top cover (31), four lockwashers (32), and screws (33). Tighten screws to 185 to 190 lb-ft (251 to 258 N•m).
- (27) Install grease fitting (34).
- (28) Apply grease to upper axle ball trunnion through lubrication fitting (34).

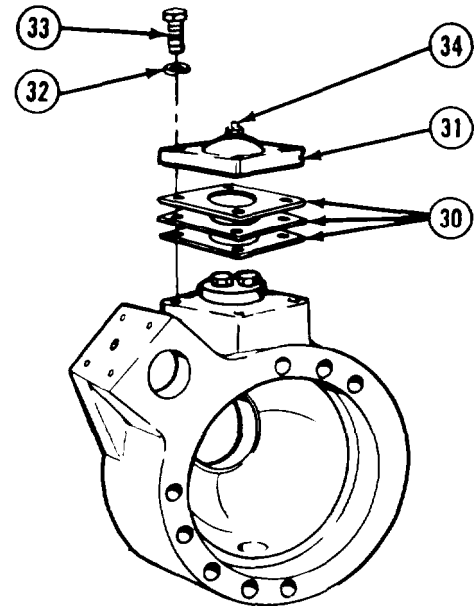

- (29) Hook spring scale on end of ball socket (3).
- (30) Pull spring scale and check that ball socket (3) will move with pull of 35 to 45 lb (16 to 20 kg). If it does, go to step (33). If less than 35 lb (16 kg) is required, go to step (31). If more than 45 lb (20 kg) is required, go to step (32).
- (31) Record number and thickness of shims and remove one shim, same thickness, from top and bottom of ball socket. Repeat step (30).
- (32) Record number and thickness of shims and add one shim, same thickness, to top and bottom of ball socket. Repeat step (30).

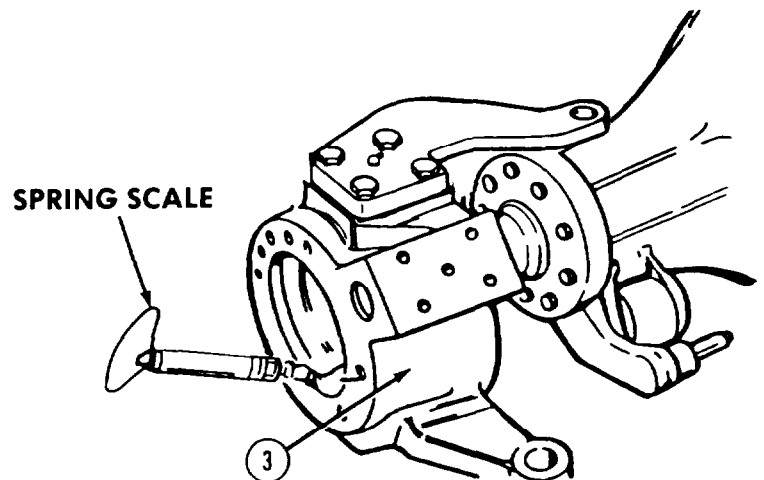

Axles No. 1 and No. 2 Maintenance Instructions (Cont)

9-13. BALL SOCKET REMOVAL/INSTALLATION (CONT).

WARNING

Adhesives, solvents, and sealing compounds can burn easily, can give off harmful vapors, and are harmful to skin and clothing. To avoid injury or death, keep away from open fire and use in well-ventilated area. If adhesive, solvent, or sealing compound gets on skin or clothing, wash immediately with soap and water.

CAUTION

Apply only one drop of adhesive to each seal joint. Excess adhesive can cause seal to become brittle and damaged.

NOTE

Cut seal ends square before installation. Be certain grooved side of seal faces upward. Seals may be one piece on Model A or two pieces glued together on Model B. Overall length should be approximately 27 in. (686 mm) long. The one piece seal should be used whenever possible. If two pieces must be used, do step (32.1). If a one piece seal is used, go to Step (33).

(32.1) Apply one drop of adhesive to each end of one seal half (34.1) and join to second seal half (34.1).

(33) Install seal (34.1) so it overlaps joint of seal retainer halves (35). Apply one drop of adhesive to one end of seal.

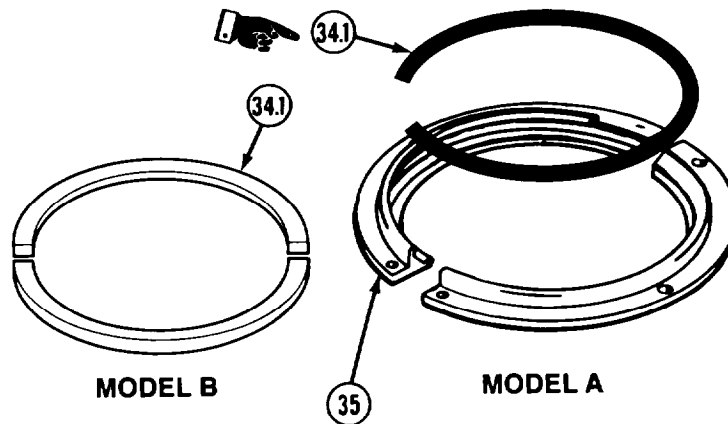

Axles No. 1 and No. 2 Maintenance Instructions (Cont)

- (34) Open second joint of seal retainer halves (35) and slide seal retainer halves over ball and bushing assembly (11).

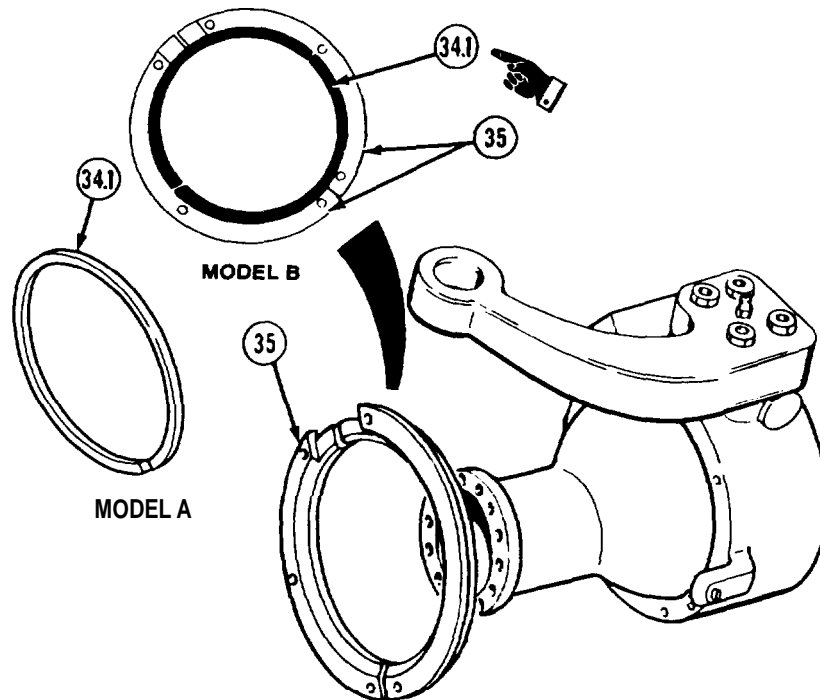
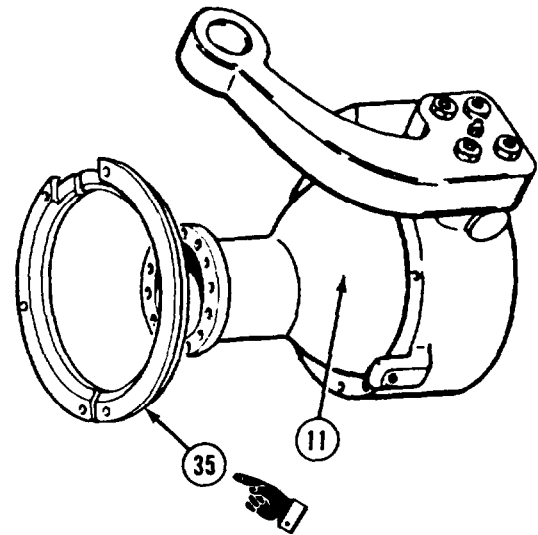

NOTE

If assembling Model A retainer, perform step (35). If assembling Model B, perform step (35.1).

- (35) Install seal retainer halves (35) and other half of seal (34.1) so it overlaps second joint and butts up against other half of seal on both ends.
- (35.1) Install seal retainer halves (35) and remainder of seal (34.1) so it overlaps second joint and butts up against other half of seal on both ends.

Axles No. 1 and No. 2 Maintenance Instructions (Cont)

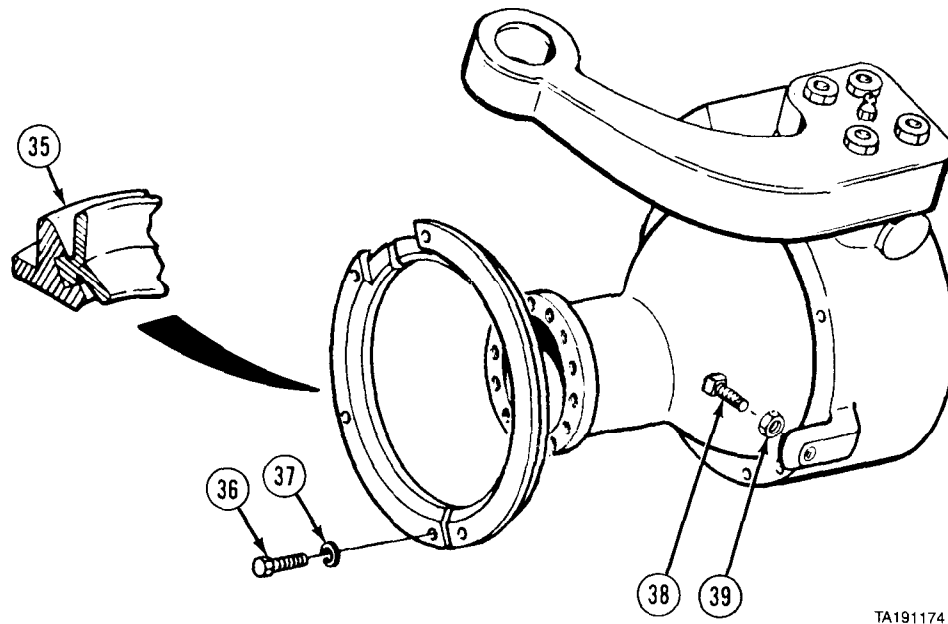
**WARNING**

Adhesives, solvents, and sealing compounds can burn easily, can give off harmful vapors, and are harmful to skin and clothing. To avoid injury or death, keep away from open fire and use in well-ventilated area. If adhesive, solvent, or sealing compound gets on skin or clothing, wash immediately with soap and water.

- (36) Apply silicone adhesive-sealant to inner sides of seal retainer halves (35) and six screws (36).
 - (37) Apply silicone adhesive-sealant between seal retainer halves (35).
 - (38) Align seal retainer halves (35) and install six lockwashers (37) and screws (36).
 - (39) Tighten six screws (36) to 25 lb-ft (34 N·m).
 - (40) Install steering stop bolt (38) and nut (39) to same measurement as recorded during removal.
- d. *Follow-on Maintenance.*
- (1) Install axle shaft assembly (para 9-2).
 - (2) Install slack adjuster and camshaft (TM 9-2320-279-20).
 - (3) Install brake chamber (TM 9-2320-279-20).
 - (4) Install tie rod (TM 9-2320-279-20).
 - (5) Install steering arm (TM 9-2320-279-20).
 - (6) Install wheel and tire assembly (TM 9-2320-279-10).
 - (7) Lubricate axle (LO 9-2320-279-12).

END OF TASK

Axles No. 1 and No. 2 Maintenance Instructions (Cont)

9-14. AXLES NO. 1 AND NO. 2 BALL, BUSHING, AND OIL SEAL REMOVAL/INSTALLATION.		
This task covers:		
a. Removal	c. Follow-on Maintenance	
b. Installation		
INITIAL SETUP		
<i>Models</i>	<i>References</i>	
All	None	
<i>Test Equipment</i>	<i>Equipment Condition</i>	
None	<i>TM or Para</i>	<i>Condition Description</i>
<i>Special Tools</i>	Para 9-13	Ball socket removed.
None	<i>Special Environmental Conditions</i>	
<i>Supplies</i>	None	
Adhesive-sealant, silicone, Item 6, Appendix C	<i>General Safety Instructions</i>	
Solvent, dry cleaning, Item 57, Appendix C	None	
<i>Personnel Required</i>	<i>Level of Maintenance</i>	
MOS 63W, Wheel vehicle repairer	Direct Support	

a. Removal.

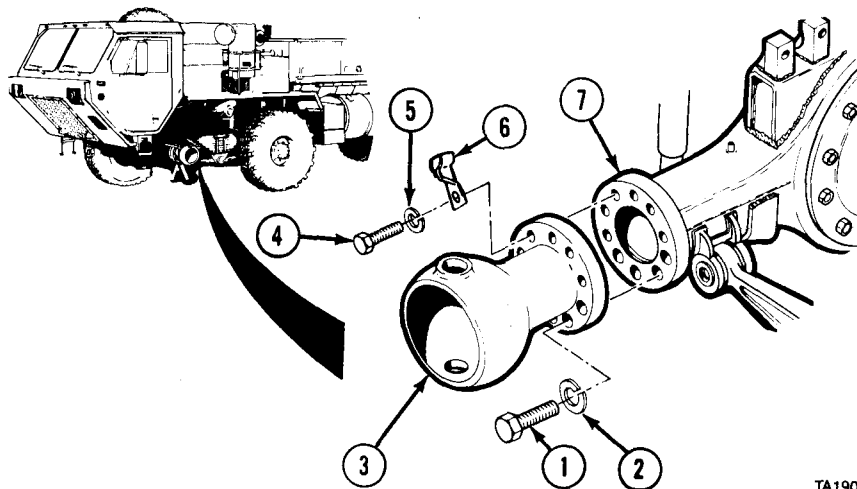

NOTE

Ball, bushing, and oil seal removal is the same for both sides of axles No. 1 and No. 2. Left side of axle No. 1 is shown.

(1) Remove four screws (1) and lockwashers (2) from bottom holes of ball and bushing assembly (3).

Axles No. 1 and No. 2 Maintenance Instructions (Cont)

WARNING

Ball and bushing assembly is heavy. Support ball and bushing assembly to keep it from falling and causing personal injury.

- (2) Remove six screws (4), lockwashers (5), and airhose mounting bracket (6).
- (3) Remove ball and bushing assembly (3) from axle housing assembly (7).
- (4) Remove old sealant from mounting face of axle housing assembly (7) and ball and bushing assembly (3).
- (5) Pry oil seal (8) from ball and bushing assembly (3).
- (6) Measure front axle outer diameter and inner diameter of axle ball bushing (9). If difference in measurement is less than 0.008 in. (0.203 mm) or more than 0.020 in. (0.508 mm), remove bushing from axle ball (10).

WARNING

Adhesives, solvents, and sealing compounds can burn easily, can give off harmful vapors, and are harmful to skin and clothing. To avoid injury or death, keep away from open fire and use in well-ventilated area. If adhesive, solvent, or sealing compound gets on skin or clothing, wash immediately with soap and water.

- (7) Clean axle ball (10) with soft, lint-free cloth and dry cleaning solvent.
- (8) Inspect axle ball (10) for scratches and grooves. Replace axle ball if damaged.

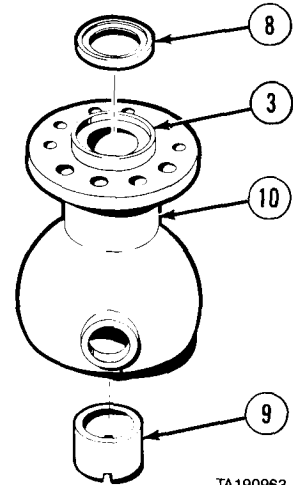

TA190963

b. Installation.

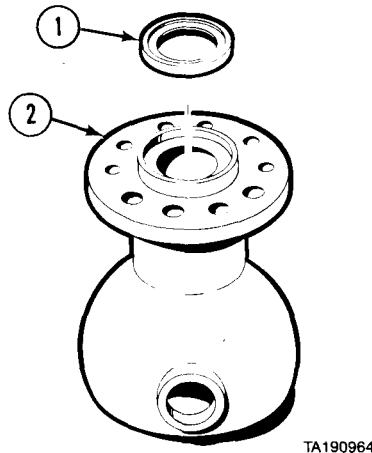

TA190964

NOTE

Installation of ball, bushing, and oil seal is the same for both sides of axles No. 1 and No. 2.

- (1) Install oil seal (1) in axle ball (2).

Axles No. 1 and No. 2 Maintenance Instructions (Cont)

9-14. AXLES NO. 1 AND NO. 2 BALL, BUSHING, AND OIL SEAL REMOVAL/INSTALLATION (CONT).

- (2) Support axle ball (2) on blocks to protect seal end of assembly.
- (3) Install axle ball bushing (3) in axle ball (2) so grease slots (4) are aligned with trunnion holes (5) and open ends of grease slots face up.

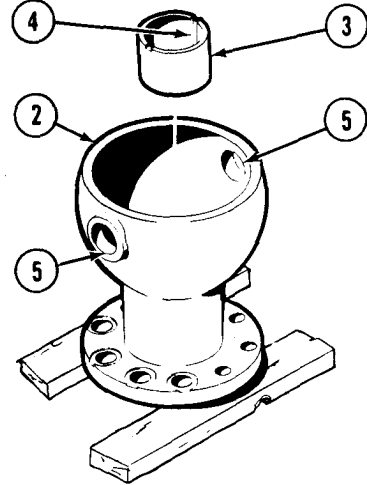

TA190965

WARNING

Adhesives, solvents, and sealing compounds can burn easily, can give off harmful vapors, and are harmful to skin and clothing. To avoid injury or death, keep away from open fire and use in well-ventilated area. If adhesive, solvent, or sealing compound gets on skin or clothing, wash immediately with soap and water.

- (4) Coat mounting face of axle housing assembly (6) with silicone adhesive-sealant.
- (5) Install ball and bushing assembly (7) and airhose mounting bracket (8) on axle housing assembly (6) with six screws (9), lockwashers (10), four screws (11), and lockwashers (12).

c. *Follow-on Maintenance.* Install ball socket (para 9-13).

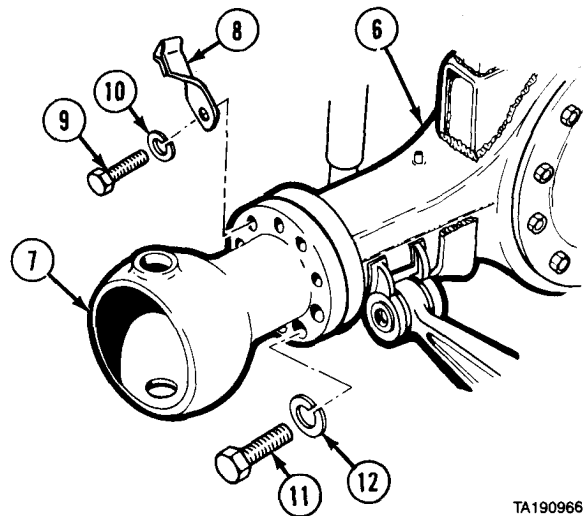

TA190966

END OF TASK

INDEX

Subject	Paragraph Figure, Table Number
A	
Adhesive and solvent warning	a
Alarm box, tilt (M983) removal/installation	6-10
Alarm, tilt warning, switch (M983) removal/installation	6-7
Alternator Repair	6-2
Army materiel, destruction of, to prevent enemy use	1-3
Arctic coolant pump test	F 2-9
Arctic heater fault codes (Model B)	F 2-10
Asbestos warning	c
Assembly, axle shaft removal/repair/installation	9-2
Assembly, axle housing cover, axle No. 2 removal/repair/installation	9-5
Attaching engine to engine stand	3-4
Attaching transmission to transmission stand	7-5
Audible and visual level warning indicators (M983) removal/installation	6-5
Axle housing cover assembly, axle No. 2 removal/repair/installation	9-5
Axle No. 1 removal/installation	9-3
Axle No. 1, differential carrier	
Removal/Installation	9-7
Repair	9-11
Axle No. 2 removal/installation	9-4
Axle No. 2, axle housing cover assembly removal/repair/installation	9-5
Axle No. 2, differential carrier	
Removal/Installation	9-10
Repair	9-12
Axle No. 2, differential carrier cover	
Removal/Installation	9-8
Repair	9-9
Axle shaft assembly removal/repair/installation	9-2
Axles No. 1 and No. 2, axle shaft assembly removal/repair/installation	9-2
Axles No. 1 and No. 2 ball, bushing, and oil seal removal/installation	9-14
Axles No. 1 and No. 2 ball socket removal/installation	9-13
Axles No. 1 and No. 2 yoke and oil seal removal/installation	9-6
B	
Ball, bushing, and oil seal, axles No. 1 and No. 2 removal/installation	9-14
Ball socket removal/installation	9-13
Batteries, terminals, and cables warning	c
Board, crane control distribution (M983) removal/installation	6-8
Body, control valve removal/repair/installation	7-20
Body, lockup cutoff valve removal/repair/installation	7-22
Box, junction and connector (M977, M985) removal/repair/installation	6-11
Box, junction and connector (M984E1) removal/repair/installation	6-11.1
Box, tilt alarm (M983) removal/installation	6-10
Brackets, mounting, transfer case removal/installation	8-3
Bushing, ball, and oil seal, axles No. 1 and No. 2 removal/installation	9-14
C	
Cab wiring harness removal/installation	6-13
Cables, power interconnecting (M983) removal/installation	6-9
Capabilities, features, and characteristics, equipment	1-11
Carbon monoxide (exhaust gas) warning	a
Care, handling, and safety	1-14
Carrier cover, differential, axle No. 2	
Removal/Installation	9-8
Repair	9-9

INDEX (CONT)

Subject	Paragraph, Figure, Table Number
Carrier, differential, axle No. 1	
Removal/Installation	9-7
Repair	9-11
Carrier, differential, axle No. 2	
Removal/Installation	9-10
Repair	9-12
Case, transfer, lock-up valve, HI-LO range repair	8-12
Case, transfer	
Removal/Installation	8-2
Repair	8-4
Case, transfer, mounting brackets removal/installation	8-3
Center shaft repair	8-7
Center support housing and second clutch removal/repair/installation	7-19
Center support housing and third clutch removal/repair/installation	7-18
Chamber, lockout shift removal/repair/installation	8-14
Characteristics, capabilities, and features, equipment	1-11
Chassis/Engine wiring harness removal/installation	6-16
Chassis wiring harness removal/installation	6-15
Chassis wiring harness (M984E1) removal/installation	6-15.1
Cleaning instructions and warnings, general	2-8
Clutch assembly, first, and rear cover removal/repair/installation	7-16
Clutch assembly, forward removal/repair/installation	7-15
Clutch assembly, fourth removal/installation	7-17
Clutch, second, and center support housing removal/installation	7-19
Clutch, third, and center support housing removal/repair/installation	7-18
Common tools and equipment.	2-2
Components, major, location and description	1-12
Compressed air warning	c
Connector and junction box (M977, M985) removal/repair/installation	6-11
Connector and junction box (M984E1) removal/repair/installation	6-11.1
Control distribution board, crane (M983) removal/installation	6-8
Control valve body removal/repair/installation.	7-20
Control valve, traction repair.	8-13
Converter, torque, housing removal/repair/installation	7-9
Converter, torque, pump removal/repair/installation	7-8
Converter, torque, stator removal/repair/installation	7-7
Cooling system maintenance	5-1
Cover assembly, axle No. 2, axle housing removal/repair/installation	9-5
Cover, differential carrier, axle No. 2	
Removal/Installation	9-8
Repair	9-9
Cover, rear, and first clutch assembly removal/repair/installation	7-16
Crane (M977, M985) troubleshooting	2-7
Crane (M983) troubleshooting	2-7
Crane control distribution board (M983) removal/installation	6-8
Crane, material handling, shutdown system	1-14
Crane operating instruction plate locations	1-14
Crane overload sensor switches removal/installation (M977, M985)	6-12
Crane overload sensor switches, plate, and terminal box (M984E1) removal/installation	6-12.1
Cross-Reference, nomenclature	1-5
Cutoff valve body, lockup removal/repair/installation	7-22

INDEX

Subject	Paragraph Figure, Table Number
D	
Description and data, equipment	1-10
Description and location of major components	1-12
Destruction of Army materiel to prevent enemy use	1-3
Differences between models	1-13
Differential carrier, axle No. 1	
Removal/Installation	9-7
Repair	9-11
Differential carrier, axle No. 2	
Removal/Installation	9-10
Repair	9-12
Differential carrier cover, axle No. 2	
Removal/Installation	9-8
Repair	9-9
Distribution board, crane control (M983) removal/installation	6-8
Dust shield, oil seal, and output yoke removal/installation	7-14
E	
Electric motors tester circuit schematic (M983)	F 2-7
Electric motors tester circuit wiring diagram (M983)	F 2-8
Electrical system maintenance	6-1
Element, filter, internal removal/installation	7-12
Engine removal/installation	3-3
Engine arctic heater-troubleshooting	2-7
Engine/Chassis wiring harness removal/installation	6-16
Engine, general maintenance instructions	3-2
Engine maintenance	3-1
Engine to engine stand removal/installation	3-4
Engine troubleshooting	2-7
Engine wiring harness removal/installation	6-14
Equipment characteristics, capabilities, and features	1-11
Equipment description and data	1-12
Equipment improvement recommendations (EIR), reporting	1-6
Equipment improvement report and maintenance digest (EIR MD)	1-7
Equipment improvement report and maintenance summary (EIR MS)	1-7
Equipment names and models	1-1
Equipment, common	2-2
Equipment, purpose of	1-1
Equipment, test	2-4
Extended switch, outrigger (M983) removal/installation	6-6
F	
Features, equipment	1-11
Filter element, internal removal/installation	7-12
First clutch assembly and rear cover removal/repair/installation	7-16
Flywheel assembly removal/repair/installation	7-6
Forms, records, and reports, maintenance	1-2
Forward clutch assembly removal/repair/installation	7-15
Fourth clutch assembly removal/repair/installation	7-17
Front output shaft, lower repair	8-9
Fuel system maintenance	4-1
Fuel warning	a

INDEX (CONT)

Subject	Paragraph, Figure, Table Number
G	
Gear unit and main shaft assembly removal/repair/installation	7-13
General information	1-1
Cleaning instructions and warnings.	2-8
Information	1-1
Maintenance instructions	2-8
Governor removal/installation	7-23
H	
Harness, cab wiring removal/installation	6-13
Harness, chassis wiring removal/installation	6-15
Harness, chassis wiring (M984E1) removal/installation	6-15.1
Harness, chassis/engine wiring removal/installation	6-16
Harness, engine wiring removal/installation	6-14
Harness, STE/ICE wiring removal/installation.	6-17
Hazards, significant, and safety recommendations	1-14
Heavy-duty winch (M984) troubleshooting	2-7
High voltage warning	b
HI-LO range transfer case lock-up valve repair	8-12
Hot exhaust pipe/muffler warning	b
Hot radiator warning	b
Housing cover assembly, axle, axle No. 2 removal/repair/installation	9-5
Housing, second clutch and center support removal/repair/installation.	7-19
Housing, third clutch and center support removal/repair/installation	7-18
Housing, torque converter removal/repair/installation	7-9
Housing, transmission repair	7-10
How to use this manual	vi
Hydraulic system-troubleshooting	2-7
I	
ICE/STE wiring harness removal/installation	6-17
Identification, tanker component	2-8
Illustrated list of manufactured items, Appendix B	B-1
Illustrations, list of	iv
Indicator, visual and audible level warning (M983) removal/installation	6-5
Information, warranty	1-8
Input shaft, top repair	8-6
Inspection, pre-embarkation	2-11
Instructions	
Lubrication	2-9
Maintenance	2-8
Pre-embarkation inspection	2-11
Preparation for storage or shipment	2-10
Troubleshooting	2-7
Interconnecting cables, power (M983) removal/installation	6-9
Internal filter element removal/installation	7-12
Introduction	1-1
Introduction, troubleshooting	2-6
J	
Jewelry, wearing, warning.	a
Junction box and connector (M977, M985) removal/repair/installation	6-11
Junction box and connector (M984E1) removal/repair/installation	6-11.1
L	
Level warning indicators, visual and audible (M983) removal/installation	6-5
List of illustrations	iv

INDEX (CONT)

Subject	Paragraph, Figure, Table Number
List of tables	v i
Location and description of major components	1-12
Lockout shift chamber removal/repair/installation	8-14
Lock-up valve, transfer case, HI-LO range repair	8-12
Lockup cutoff valve body removal/repair/installation	7-22
Lower front output shaft repair	8-9
Lower rear output shaft repair	8-8
Lower shift rod assembly repair	8-11
Lubrication instructions	2-9
Lubrication pump	
Removal/Installation	8-15
Repair	8-16
M	
Main control valve (M983)	F 2-2
Main shaft assembly and gear unit removal/repair/installation	7-13
Maintenance	
Electrical system	6-1
Engine, general instructions	3-2
Forms, records, and reports	1-2
Fuel system	4-1
Instructions, general	2-8
Instructions, transmission, general	2-8
Maintenance digest (EIR MD), equipment improvement report	1-7
Maintenance summary (EIR MS), equipment improvement report	1-7
Major components, location and description	1-12
Manual	
How to use	v i
Type of	1-1
Material handling crane - troubleshooting	2-7
Metric system	1-9
Model numbers and equipment names	1-1
Models, difference between	1-13
Modulator valve removal/installation	7-21
Motor, starter, repair and testing	6-4
Mounting brackets, transfer case removal/installation	8-3
N	
Names, equipment, and model numbers	1-10
No. 1 axle removal/installation	9-3
No. 1 axle, differential carrier	
Removal/Installation	9-7
Repair	9-11
No. 2 axle removal/installation	9-4
No. 2 axle, axle housing cover assembly removal/repair/installation	9-5
No. 2 axle, differential carrier	
Removal/Installation	9-10
Repair	9-12
No. 2 axle, differential carrier cover	
Removal/Installation	9-8
Repair	9-9
No. 1 and No. 2 axles ball, bushing, and oil seal removal/installation	9-14
No. 1 and No. 2 axles, ball socket removal/installation	9-13
No. 1 and No. 2 axle shaft assembly removal/repair/installation	9-2
No. 1 and No. 2 axles, yoke and oil seal removal/installation	9-6

INDEX (CONT)

Subject	Paragraph, Figure, Table Number
Nomenclature cross-reference	1-5
Nuclear, biological, or chemical exposure warning	a
Numbers, model, and equipment names	1-1
O	
Oil cooler (see radiator) repair	5-2
Oil pan, transmission removal/installation	7-11
Oil seal removal/installation	8-5
Oil seal and yoke, axles No. 1 and No. 2 removal/installation	9-6
Oil seal, ball, and bushing, axles No. 1 and No. 2 removal/installation	9-14
Oil seal, output yoke, and dust shield (transmission) removal/installation	7-14
Operation, principles of	1-15
Output shaft, lower front repair	8-9
Output shaft, lower rear repair	8-8
Output yoke, dust shield, and oil seal removal/installation	7-14
Outrigger control valve (M983)	F 2-3
Outrigger extended switch (M983) removal/installation	6-6
Overload sensor switch (M977, M985), crane removal/installation	6-12
Overload sensor switches, plate, and terminal box (M984E1), crane removal/installation	6-12.1
P	
Pan, oil, transmission removal/installation	7-11
Parking brake, incorrect use of, warning	a
Plate and terminal box, overload sensor switches (M984E1), crane removal/installation	6-12.1
Plate locations, crane operating instruction	1-14
Power distribution board wiring diagram (M983)	F 2-6
Power interconnecting cables (M983) removal/installation	6-9
Pre-embarkation inspection	2-11
Preparation for storage or shipment	2-10
Pressure tester setup (M983)	F 2-5
Prevent enemy use, destruction of army equipment	1-3
Principles of operation	1-15
Pump, lubrication, transfer case	
Removal/Installation	8-15
Repair	8-16
Pump, torque converter removal/repair/installation	7-8
Purpose of equipment	1-1
R	
Radiator repair	5-2
Range, HI-LO, transfer case lock-up valve repair	8-12
Rear cover and first clutch assembly removal/repair/installation	7-16
Rear output shaft, lower repair	8-8
Recommendations (EIR), reporting equipment improvement	1-6
Records, reports, and forms, maintenance	1-2
Repair parts	2-5
Reporting equipment improvement recommendations (EIR)	1-6
Reports, forms, and records, maintenance	1-2
Rod assembly, transfer case, lower shift repair	8-11
Rod assembly, transfer case, upper shift repair	8-10
S	
Safety, care, and handling	1-14
Safety recommendations and significant hazards	1-14
Scope	1-1
Seal, oil, transfer case removal/installation	8-5
Seal, oil, and yoke, axles No. 1 and 2 removal/installation	9-6

INDEX (CONT)

Subject	Paragraph, Figure, Table Number
Seal, oil, axles No. 1 and No. 2 ball and bushing removal/installation	9-14
Seal, oil, transmission output yoke, and dust shield removal/installation	7-14
Seatbelts use warning	b
Second clutch and center support housing removal/repair/installation	7-19
Sensor switch, overload (M977, M985), crane removal/installation	6-12
Sensor switches, overload and plate and terminal box (M984E1), crane removal/installation	6-12.1
Shaft assembly, main and gear unit removal/repair/installation	7-13
Shaft assembly, No. 1 and No. 2 axles removal/repair/installation	9-2
Shaft, center repair	8-7
Shaft, lower front output repair.	8-9
Shaft, lower rear output repair.	8-8
Shaft, top input	8-6
Shield, dust, oil seal, and output yoke removal/installation	7-14
Shift chamber, lockout removal/repair/installation.	8-14
Shift rod assembly, lower repair	8-11
Shift rod assembly, upper repair.	8-10
Shift tower, transmission repair	7-3
Shipment or storage, preparation for	2-10
Significant hazards and safety recommendations	1-14
Socket, ball removal/installation	9-13
Solenoid, starter removal/installation	6-3
Special tools	2-3
Stand, engine to engine removal/installation	3-4
Starter motor repair and testing	6-4
Starter solenoid removal/installation	6-3
Starting fluid warning	c
Stator, torque converter removal/repair/installation	7-7
Steering system - troubleshooting	2-7
STE/ICE wiring harness removal/installation	6-17
Storage or shipment, preparation for	2-10
Subject index, troubleshooting	T 2-2
Support housing, center, and second clutch removal/repair/installation	7-19
Support housing, center, and third clutch removal/repair/installation	7-18
Switch, outrigger extended (M983) removal/installation	6-6
Switch, tilt warning alarm (M983) removal/installation	6-7
Switch, overload sensor (M977, M985), crane removal/installation	6-12
Switches, overload sensor and plate and terminal box (M984E1), crane removal/installation	6-12.1
Symptom index, troubleshooting	T 2-1
System	
Cooling	5-1
Electrical	6-1
Metric	1-9
System back pressure (M983 crane)	F 2-4
System symptom index (troubleshooting)	T 2-1
T	
Table of contents	i
Tables, list of	vi
Terminal box and plate, overload sensor switches (M984E1), crane removal/installation	6-12.1
Test equipment	2-4
Testing, motor starter repair.	6-4
Third clutch and center support housing removal/repair/installation	7-18
Throttle treadle valve repair.	4-2
Tilt alarm box (M983) removal/installation	6-10

INDEX (CONT)

Subject	Paragraph, Figure, Table Number
Tilt warning alarm switch (M983) removal/installation	6-7
Tools, common	2-2
Tools, special	2-3
Top input shaft repair	8-6
Torque converter	
Housing removal/repair/installation.	7-9
Pump removal/repair/installation	7-8
Stator removal/repair/installation	7-7
Tower, shift, transmission repair.	7-3
Traction control valve repair.	8-13
Trailer brake warning	b
Transfer case	
HI-LO range, lock-up valve repair	8-12
Lockout shift chamber removal/repair/installation	8-14
Lower front output shaft repair.	8-9
Lower rear output shaft repair.	8-8
Lower shift rod assembly repair.	8-11
Lubrication pump removal/installation	8-15
Lubrication pump repair	8-16
Maintenance	8-1
Mounting brackets removal/installation	8-3
Oil seal removal/installation	8-5
Removal/Installation	8-2
Repair	8-4
Shift rod assembly, lower repair.	8-11
Shift rod assembly, upper repair.	8-10
Top input shaft repair	8-6
Transmission	
Control valve body removal/repair/installation	7-20
Forward clutch assembly removal/repair/installation	7-15
Fourth clutch assembly removal/repair/installation	7-17
General maintenance instructions	7-2
Housing repair	7-10
Internal filter element removal/installation	7-12
Lockup cutoff valve body removal/repair/installation	7-22
Main shaft assembly and gear unit removal/repair/installation	7-13
Maintenance	7-1
Modulator valve removal/installation	7-21
Oil pan removal/installation.	7-11
Oil seal, output yoke, and dust shield removal/installation	7-14
Removal/Installation	7-4
Removal/Installation on stand.	7-5
Shaft assembly, main and gear unit removal/repair/installation	7-13
Shift tower repair	7-3
Third clutch and center support housing removal/repair/installation	7-18
Troubleshooting	2-7
Treadle valve, throttle repair.	4-2
Troubleshooting	2-6
Engine	2-7

INDEX (CONT)

Subject	Paragraph, Figure, Table Number
Troubleshooting (Cont)	
Engine arctic heater	2-7
Hydraulic system	2-7
Instructions	2-7
Introduction	2-6
Material handling crane	2-7
Procedures	T 2-3
Steering system	2-7
Subject index	T 2-2
Symptom index	T 2-1
Tanker system	2-7
Transmission	2-7
Type of manual	1-1
U	
Unit, gear, and main shaft assembly removal/repair/installation.	7-13
Upper shift rod assembly repair	8-10
V	
Valve body, control removal/repair/installation.	7-20
Valve body, lockup cutoff removal/repair/installation	7-22
Valve, modulator removal/installation	7-21
Valve, throttle treadle repair	4-2
Valve, traction control repair	8-13
Valve, transfer case lock-up, HI-LO range repair	8-12
Vehicle description	1-10
Visual and audible level warning indicators (M983) removal/installation.	6-5
W	
Warning alarm switch, tilt removal/installation	6-7
Warning indicators, visual and audible level (M983) removal/installation	6-5
Warnings	
Adhesives and solvents	a
Asbestos in brake linings.	c
Batteries, terminals, and cables	c
Carbon monoxide (exhaust gas)	a
Compressed air	c
Crane operation under powerlines.	b
Fuel	a
High voltage	b
Hot exhaust pipe/muffler	b
Hot radiator	b
Jewelry, wearing of	a
“Low” voltage	b
Nuclear, biological, or chemical (NBC) exposure	c
Parking brake, incorrect use of	a
Seatbelts, use of	b
Starting fluid	c
Trailer brakes	b
Winch cable, handling of	b
Winch operation	b
Warranty information	1-8
Wiring diagrams	
Electric motor tester circuit.	F 2-8
Engine arctic heater	F 2-9
Power distribution board (M983)	F 2-6
Wiring harness removal/installation	
Cab	6-13

INDEX (CONT)

Subject	Paragraph, Figure, Table Number
Wiring harness removal/installation (Cont)	
Chassis	6-15
Chassis (M984E1)	6-15.1
Chassis/Engine	6-16
Engine	6-14
STE/ICE	6-17
	Y
Yoke and oil seal, axles No. 1 and No. 2 removal/installation	9-6
Yoke, output, dust shield, and oil seal removal/installation	7-14

By Order of the Secretary of the Army:

JOHN A. WICKHAM, JR.
General United States Army
Chief of Staff

Official:

R.L. DILWORTH
Brigadier General, United States Army
The Adjutant General

Distribution:

To be distributed in accordance with DA Form 12-38, Direct and General Support Maintenance requirements for Truck, Cargo, 10-Ton, 8x8, Heavy Expanded Mobility, Tactical Truck, HEMTT, M977, M978, M983, M984, and M985.

☆ U. S. GOVERNMENT PRINTING OFFICE : 1993 - 311-831 (62450)

RECOMMENDED CHANGES TO EQUIPMENT PUBLICATIONS



THEN - JOT DOWN THE INFO ON THIS FORM---TEAR OUT THIS PAGE---FOLD IT---AND DROP IT IN THE MAIL!

SOMETHING WRONG WITH THIS PUBLICATION?

FROM: (IMPRINT YOUR UNIT'S COMPLETE ADDRESS)

HQ & HQ CO.
46TH TRANS. BN.
FT. CARSON, CO

DATE SENT: 5 JAN., 1997

PUBLICATION NUMBER
TM 9-2320-279-34

PUBLICATION DATE
3 JUNE 1987

PUBLICATION TITLE DIRECT SUPPORT
AND GENERAL SUPPORT MAINTENANCE
MANUAL M977 Series Vehicles

BE EXACT...PINPOINT WHERE IT IS

PAGE NO.	PARA-GRAPH	FIGURE NO.	TABLE NO.
21-8	21-2	NA	NA

IN THIS SPACE, TELL WHAT IS WRONG AND WHAT SHOULD BE DONE ABOUT IT:

In para 21-2.c, Assembly, step (1) user is not cautioned about touching commutator.

Add caution to not touch commutator of armature during assembly so oils from skin will not damage it.

SAMPLE

TEAR ALONG PERFORATED LINE

PRINTED NAME, GRADE OR TITLE, AND TELEPHONE NUMBER
ALBERT RAND, SSG. 226-5644

SIGN HERE:
Albert Rand

DA FORM 2028-2
1 JUL 79

PREVIOUS EDITIONS ARE OBSOLETE.

P.S. IF YOUR OUTFIT WANTS TO KNOW ABOUT YOUR RECOMMENDATION, MAKE A CARBON COPY OF THIS AND GIVE IT TO YOUR HEADQUARTERS.

RECOMMENDED CHANGES TO EQUIPMENT PUBLICATIONS

	<h2 style="margin: 0;">SOMETHING WRONG</h2> <p style="margin: 0;">WITH THIS PUBLICATION?</p>
<p style="font-size: small; margin: 0;">THEN - JOT DOWN THE INFO ON THIS FORM---TEAR OUT THIS PAGE---FOLD IT---AND DROP IT IN THE MAIL!</p>	<p style="font-size: x-small; margin: 0;">FROM: (IMPRINT YOUR UNIT'S COMPLETE ADDRESS)</p> <p style="font-size: x-small; margin: 0;">DATE SENT:</p>

<p style="font-size: x-small; margin: 0;">PUBLICATION NUMBER</p> <p style="margin: 0;">TM 9-2320-279-34-1</p>	<p style="font-size: x-small; margin: 0;">PUBLICATION DATE</p> <p style="margin: 0;">3 JUNE 1987</p>	<p style="font-size: x-small; margin: 0;">PUBLICATION TITLE</p> <p style="margin: 0;">DIRECT SUPPORT AND GENERAL SUPPORT MAINTENANCE MANUAL M977 Series Vehicles</p>
---	--	---

BE EXACT...PINPOINT WHERE IT IS				IN THIS SPACE, TELL WHAT IS WRONG AND WHAT SHOULD BE DONE ABOUT IT:
PAGE NO.	PARA-GRAPH	FIGURE NO.	TABLE NO.	

TEAR ALONG PERFORATED LINE

<p style="font-size: x-small; margin: 0;">PRINTED NAME, GRADE OR TITLE, AND TELEPHONE NUMBER</p>	<p style="font-size: x-small; margin: 0;">SIGN HERE:</p>
--	--

FILL IN YOUR
UNIT'S ADDRESS



FOLD BACK

DEPARTMENT OF THE ARMY



OFFICIAL BUSINESS

NO POSTAGE
NECESSARY
IF MAILED
IN THE
UNITED STATES

BUSINESS REPLY MAIL

FIRST CLASS

BRM PERMIT NO. 82

ROCK ISLAND, IL

POSTAGE WILL BE PAID BY ROCK ISLAND ARSENAL



Director
Armament and Chemical Acquisition
and Logistics Activity
ATTN: AMSTA-AC-NML
Rock Island, IL 61201-9948

TEAR ALONG PERFORATED LINE



THE METRIC SYSTEM AND EQUIVALENTS

LINEAR MEASURE

1 Centimeter = 10 Millimeters = 0.01 Meters = 0.3937 Inches
 1 Meter = 100 Centimeters = 1000 Millimeters = 39.37 Inches
 1 Kilometer = 1000 Meters = 0.621 Miles

SQUARE MEASURE

1 Sq Centimeter = 100 Sq Millimeters = 0.155 Sq Inches
 1 Sq Meter = 10,000 Sq Centimeters = 10.76 Sq Feet
 1 Sq Kilometer = 1,000,000 Sq Meters = 0.386 Sq Miles

WEIGHTS

1 Gram = 0.001 Kilograms = 1000 Milligrams = 0.035 Ounces
 1 Kilogram = 1000 Grams = 2.2 Lb
 1 Metric Ton = 1000 Kilograms = 1 Megagram = 1.1 Short Tons

CUBIC MEASURE

1 Cu Centimeter = 1000 Cu Millimeters = 0.06 Cu Inches
 1 Cu Meter = 1,000,000 Cu Centimeters = 35.31 Cu Feet

LIQUID MEASURE

1 Milliliter = 0.001 Liters = 0.0338 Fluid Ounces
 1 Liter = 1000 Milliliters = 33.82 Fluid Ounces

TEMPERATURE

$5/9 (^{\circ}\text{F} - 32) = ^{\circ}\text{C}$
 212^o Fahrenheit is equivalent to 100^o Celsius
 90^o Fahrenheit is equivalent to 32.2^o Celsius
 32^o Fahrenheit is equivalent to 0^o Celsius
 $9/5 \text{ C}^{\circ} + 32 = \text{F}^{\circ}$

APPROXIMATE CONVERSION FACTORS

<u>TO CHANGE</u>	<u>TO</u>	<u>MULTIPLY BY</u>
Inches	Centimeters	2.540
Feet	Meters	0.305
Yards	Meters	0.914
Miles	Kilometers	1.609
Square Inches	Square Centimeters	6.451
Square Feet	Square Meters	0.093
Square Yards	Square Meters	0.836
Square Miles	Square Kilometers	2.590
Acres	Square Hectometers	0.405
Cubic Feet	Cubic Meters	0.028
Cubic Yards	Cubic Meters	0.765
Fluid Ounces	Milliliters	29.573
Pints	Liters	0.473
Quarts	Liters	0.946
Gallons	Liters	3.785
Ounces	Grams	28.349
Pounds	Kilograms	0.454
Short Tons	Metric Tons	0.907
Pound-Feet	Newton-Meters	1.356
Pounds per Square Inch	Kilopascals	6.895
Miles per Gallon	Kilometers per Liter	0.425
Miles per Hour	Kilometers per Hour	1.609

<u>TO CHANGE</u>	<u>TO</u>	<u>MULTIPLY BY</u>
Centimeters	Inches	0.394
Meters	Feet	3.280
Meters	Yards	1.094
Kilometers	Miles	0.621
Square Centimeters	Square Inches	0.155
Square Meters	Square Feet	10.764
Square Meters	Square Yards	1.196
Square Kilometers	Square Miles	0.386
Square Hectometers	Acres	2.471
Cubic Meters	Cubic Feet	35.315
Cubic Meters	Cubic Yards	1.308
Milliliters	Fluid Ounces	0.034
Liters	Pints	2.113
Liters	Quarts	1.057
Liters	Gallons	0.264
Grams	Ounces	0.035
Kilograms	Pounds	2.205
Metric Tons	Short Tons	1.102
Newton-Meters	Pound-Feet	0.738
Kilopascals	Pounds per Square Inch	0.145
Kilometers per Liter	Miles per Gallon	2.354
Kilometers per Hour	Miles per Hour	0.621

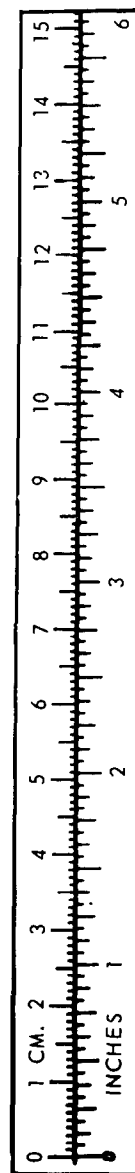

TA184454

PIN: 062143-000

This fine document...

Was brought to you by me:



[Liberated Manuals -- free army and government manuals](#)

Why do I do it? I am tired of sleazy CD-ROM sellers, who take publicly available information, slap “watermarks” and other junk on it, and sell it. Those masters of search engine manipulation make sure that their sites that sell free information, come up first in search engines. They did not create it... They did not even scan it... Why should they get your money? Why are not letting you give those free manuals to your friends?

I am setting this document FREE. This document was made by the US Government and is NOT protected by Copyright. Feel free to share, republish, sell and so on.

I am not asking you for donations, fees or handouts. If you can, please provide a link to liberatedmanuals.com, so that free manuals come up first in search engines:

<A HREF=<http://www.liberatedmanuals.com/>>Free Military and Government Manuals

– Sincerely
Igor Chudov
<http://igor.chudov.com/>