

Pack No.	ITEM	QTY	DESCRIPTION	PART NO.	MM PART NO.	NOTE
1	8	1	INSTALLATION INSTRUCTION	12469068	983-69068	
2	28	2	WASHER	2436167	983-0006	
2	33	2	SCREW	B1821BH075C550N	983-0043	
3	24	6	NUT	M45913\4-10CG8Z	983-0047	
3	32	6	SCREW	B1821BH063C400N	983-0008	
4	25	2	NUT	M45913\4-12CG8Z	983-0010	
4	29	2	WASHER	2436168	983-0011	
5	18	3	SPACER	12469395	983-92-52000	
5	22	4	NUT	M45913\4-6CG8Z	983-0025	
5	31	3	BOLT	B1821BH038C175N	983-0020	
6	1	1	CONNECTOR	8741492	983-0018	
6	21	1	ADAPTER	MS27147-1	983-0019	
6	23	4	NUT	M45913/4-8CG8Z	983-0003	
7	26	1	BREAKER	AA55571\01-001	983-0014	
7	27	2	SCREW	449617	983-0015	
8	4	1	WIRE	12469065-1	983-93-50071	
8	19	7	STRAPS	MS3367-1-0	983-0016	
9	5	1	WIRE	12469065-2	983-93-50055	
9	30	4	SCREW	9406088	983-0013	
10	14	1	HOSE	12469392-4	983-88-00C47	
11		2	O-RING, HOSES	12340395	983-0012	
12	13	1	HOSE	12469392-3	983-88-00C36	
13	6	1	DECAL	12469066	983-0021	
14	7	1	DECAL	12469067	983-0022	
15	20	6	WIRE TIE	MS3367-7-7-0	983-0017	
16	10	1	HAND CONTROLLER	12469356-1	983-74-1001	1
17	3	1	PLUG CONTROLLER	12469064	983-74-1002	1
18	11	1	U-END	12469357	983-90-50201	
19	15	1	BRACKET LH	12469393-1	983-0004	1
20	16	1	BRACKET RH	12469393-2	983-0005	1
21	9	1	SNATCH BLOCK & SHACKLE	12469355	983-60-50085-A	1
22	17	1	STRAP	12469394	983-60-50089	1
23	2	1	BRACKET	12460270-1	983-12460270-1	1
	12	1	WINCH, VALVE, BUMPER	12469358	983-75-50050CVB	1

### NOTES:

1. CAGE CODE 0GZB7



2121 Blount Road  
Pompano Beach FL 33069

### APPLICATION

57K3541  
HYDRAULIC WINCH , ACCESSORY KIT, BUMPER

### CAGE CODE

0GZB7

## Cross-Reference

**REVISIONS**

LTR	DESCRIPTION	DATE (YR-MO-DA)	APPROVED
A	REDRAWN WITH CHANGE (AMG U1805)	02-10-09	EB

NOTES:	ITEM NO.	QTY	DESCRIPTION	PART NO.	NOTE
1. APPLICABLE STANDARDS/SPECIFICATIONS: A. MIL-STD-100F  2. THIS KIT IS APPLICABLE TO 1-1/4 TON TRUCK, M998, M998A1, AND M998A2 SERIES, LESS M996, M996A1, M997, M997A1, M997A2, M1035, M1035A1, AND M1035A2.  3. THIS KIT IS TO BE INSTALLED IN ACCORDANCE WITH INSTALLATION INSTRUCTIONS 12469068.  4. CAGE CODE 24617  5. IAW A-A-55571/1  6. IAW AS33671  7. IAW ANSI B18.2.1  B. IAW MIL-DTL-45913/4	1	1	CONNECTOR	8741492	
	2	1	BRACKET	12460270-1	
	3	1	PLUG, CONTROLLER	12469064	
	4	1	WIRE, LEAD	12469065-1	
	5	1	WIRE, LEAD	12469065-2	
	6	1	DECAL	12469066	
	7	1	DECAL	12469067	
	8	1	INSTALLATION INSTRUCTIONS	12469068	
	9	1	BLOCK, SNATCH	12469355	
	10	1	SWITCH ASSEMBLY	12469356-1	
	11	1	TUBE ASSEMBLY	12469357	

REV STATUS OF SHEETS	REV	A	A																
	SHEET	1	2																

**NSN-2590-01-456-7879**

**PART NO. 57K3541**

PMIC NA <b>APPLICATION</b>		CONTRACT NUMBER DAAE07-99-C-S027		U.S. ARMY TANK-AUTOMOTIVE COMMAND WARREN, MICHIGAN 48397-5000			
NEXT ASSY	USED ON	CONTRACTOR AM GENERAL CORP. ENGINEERING & TECHNICAL SERVICES DIV. LYONIA, MICHIGAN		<b>ACCESSORY KIT, WINCH,                  HYDRAULIC 10,500 LB</b>			
	M1045A2	DRAWN BY HD	DATE (YR-MO-DA) 98-03-30				
	M1043A2	CHECKER SML	ENGINEER J. RADTKE				
	M1025A2	DRAWING APPROVAL <i>W. Gray</i> 02-11-19					
	M1097A2	DESIGN APPROVAL <i>J. Alley</i> 02-11-20		SIZE <b>A</b>	CAGE CODE <b>19207</b>	<b>57K3541</b>	
12340789 MATL ENGR DF	M966A1 			SCALE NONE	UNIT WT. —	SHEET 1 OF 2	

9. SHOWN ON D-13.323 10. SHOWN ON D-13.324 11. SHOWN ON VF-15.111	ITEM NO.	QTY	DESCRIPTION	PART NO.	NOTE
	12	1	WINCH AND BUMPER	12469358	
	13	1	HOSE ASSEMBLY	12469392-3	
	14	1	HOSE ASSEMBLY	12469392-4	
	15	1	BRACKET, SUPPORT	12469393-1	
	16	1	BRACKET, SUPPORT	12469393-2	
	17	1	STRAP	12469394	
	18	3	SPACER	12469395	
	19	7	STRAP, TIEDOWN	MS3367-1-0	6
	20	6	STRAP, TIEDOWN	MS3367-7-0	6
	21	1	ADAPTER	MS27147-1	
	22	5	NUT	M45913/4-6CG8Z	8
	23	4	NUT	M45913/4-8CG8Z	8
	24	6	NUT	M45913/4-10CG8Z	8
	25	2	NUT	M45913/4-12CG8Z	8
	26	1	BREAKER, CIRCUIT	AA55571/01-001	5
	27	2	SCREW	449617	4,9
	28	2	WASHER	2436167	4,11
	29	2	WASHER	2436168	4,11
	30	4	SCREW	9406088	4,10
	31	3	SCREW	B1821BH038C175N	7
	32	6	SCREW	B1821BH063C400N	7
	33	2	SCREW	B1821BH075C550N	7

<b>ACCESSORY KIT, WINCH,          HYDRAULIC 10,500 LB</b>	SIZE <b>A</b>	CAGE CODE <b>19207</b>	<b>57K3541</b>		
	(AMG U1805)      02-10-09		REVISION LEVEL    A	SHEET 2	

**REVISIONS**

LTR	DESCRIPTION	DATE (YR-MO-DA)	APPROVED
A	REDRAWN WITH CHANGE (AMG U1805)	02-10-09	EB

**NOTES:**

1. APPLICABLE STANDARDS/SPECIFICATIONS:  
A. MIL-STD-100F
2. CALLOUTS IDENTIFIED AS FOLLOWS:  
\* NEW PARTS INCLUDED IN KIT  
# PARTS TO BE REMOVED AND DISCARDED  
Δ PARTS TO BE REMOVED AND REUSED
- ③ PART OF 12469064 CONTROLLER PLUG
4. ALL DIMENSIONS ARE IN INCHES.
- ⑤ PART OF 12469392-4 HOSE ASSEMBLY
- ⑥ PART OF 12469392-3 HOSE ASSEMBLY

**INSTALLATION INSTRUCTIONS  
10,500 LB HYDRAULIC WINCH  
ACCESSORY KIT**

**SECTION I. INTRODUCTION**

1-1. PURPOSE. THE PURPOSE OF THESE INSTRUCTIONS IS TO PROVIDE A PROCEDURE FOR INSTALLATION OF 10,500 LB HYDRAULIC WINCH ACCESSORY KIT ON 1-1/4 TON TRUCK, M998, M998A1, AND M998A2 SERIES, LESS M996, M996A1, M997, M997A1, M997A2, M1035, M1035A1, AND M1035A2.

REV	A	A	A	A	A	A	A	A	A	A	A	A	A	A	A	A	A	A	
SHEET	18	19	20	21	22	23	24	25	26	27	28	29	30	31	32	33	34	35	
REV STATUS OF SHEETS	REV	A	A	A	A	A	A	A	A	A	A	A	A	A	A	A	A	A	A
	SHEET	1	2	3	4	5	6	7	8	9	10	11	12	13	14	15	16	17	

PMIC NA <b>APPLICATION</b>		CONTRACT NUMBER DAAE07-99-C-S027		U.S. ARMY TANK-AUTOMOTIVE COMMAND WARREN, MICHIGAN 48397-5000			
NEXT ASSY	USED ON	CONTRACTOR AM GENERAL CORP. ENGINEERING & TECHNICAL SERVICES DIV. LIVONIA, MICHIGAN					
	M1045A2	DRAWN BY H.D.	DATE (YR-MO-DA) 98-03-30	SIZE <b>A</b>	CAGE CODE <b>19207</b>	<b>12469068</b>	
	M1043A2	CHECKER S.M.L.	ENGINEER J. RADTKE	SCALE NONE			
57K3541	M966A1	DRAWING APPROVAL <i>W Gray</i> 02-10-28		DESIGN APPROVAL <i>W Gray</i> 02-11-12			
MATL ENGR D.F.	<i>W IV</i>						

## SECTION II. INSTALLATION KIT

**2-1. NEW MATERIAL. INSTALLATION KIT 57K3541 CONTAINS THE FOLLOWING ITEMS:**

<u>PART NO.</u>	<u>NOMENCLATURE</u>	<u>QTY.</u>
8741492	CONNECTOR	1
12460270-1	BRACKET	1
12469064	PLUG, CONTROLLER	1
12469065-1	WIRE, LEAD	1
12469065-2	WIRE, LEAD	1
12469066	DECAL	1
12469067	DECAL	1
12469068	INSTALLATION INSTRUCTIONS	1
12469355	BLOCK, SNATCH	1
12469356-1	SWITCH ASSEMBLY	1
12469357	TUBE ASSEMBLY	1
12469358	WINCH AND BUMPER	1
12469392-3	HOSE ASSEMBLY	1
12469392-4	HOSE ASSEMBLY	1
12469393-1	BRACKET, SUPPORT	1
12469393-2	BRACKET, SUPPORT	1
12469394	STRAP	1
12469395	SPACER	3
MS3367-1-0	STRAP, TIEDOWN	7
MS3367-7-0	STRAP, TIEDOWN	6
MS27147-1	ADAPTER	1
M45913/4-6CG8Z	NUT	5
M45913/4-8CG8Z	NUT	4
M45913/4-10CG8Z	NUT	6
M45913/4-12CG8Z	NUT	2
AA55571/01-001	BREAKER, CIRCUIT	1
449617	SCREW	2
2436167	WASHER	2
2436168	WASHER	2
9406088	SCREW	4
B1821BH038C175N	SCREW	3
B1821BH063C400N	SCREW	6
B1821BH075C550N	SCREW	2

**2-2. THE FOLLOWING MATERIAL IS REQUIRED, BUT IS NOT INCLUDED IN KIT:**

<u>PART NO.</u>	<u>NOMENCLATURE</u>	<u>QTY.</u>
737RTV	SEALING COMPOUND	A/R
MIL-S-46163 TY.I GR.K	SEALING COMPOUND	A/R

**2-3. EXISTING MATERIAL. ALL MATERIAL REMOVED AND NOT REUSED DURING INSTALLATION WILL BE RETURNED TO STOCK FOR DISPOSITION IN ACCORDANCE WITH AR 725-50.**

<b>INSTALLATION INSTRUCTIONS, 10,500 LB HYDRAULIC WINCH ACCESSORY KIT 57K3541</b>	SIZE	CAGE CODE	12469068		
	A	19207	(AMG U1805)	02-10-09	REVISION LEVEL A SHEET 2

## SECTION III. INSTALLATION PROCEDURE

### 3-1. VEHICLE PREPARATION.

- A. APPLY VEHICLE PARKING BRAKE. (REFER TO TM 9-2320-280-10.)
- B. DISCONNECT BATTERY GROUND CABLE. (REFER TO TM 9-2320-280-20.)
- C. REMOVE FRONT BUMPER AND TOWING BRACKETS. (REFER TO TM 9-2320-280-20.)
- D. REMOVE WINCH CONTROL BOX, IF APPLICABLE. (REFER TO TM 9-2320-280-20.)
- E. REMOVE FRAME EXTENSIONS, IF APPLICABLE. (REFER TO TM 9-2320-280-20.) (REMOVAL OF HOOD IS NOT REQUIRED.)

#### NOTE

PERFORM STEPS F THROUGH J FOR ALL M998A2 SERIES WITH BRAKE PROTECTION GUARDS.

- F. REMOVE TWO NUTS, FOUR WASHERS, TWO SCREWS, AND LEFT FRONT BRAKE PROTECTION GUARD FROM BRACKETS AS SHOWN IN FIGURE 1.
- G. REMOVE NUT, TWO WASHERS, SCREW, AND BRACKET FROM FRONT CROSSMEMBER AS SHOWN IN FIGURE 1.
- H. REMOVE NUT, TWO WASHERS, SCREW, AND BRACKET FROM FRONT INTERMEDIATE CROSSMEMBER AS SHOWN IN FIGURE 1.
- I. REMOVE TWO NUTS, FOUR WASHERS, TWO SCREWS, AND RIGHT FRONT BRAKE PROTECTION GUARDS FROM BRACKET AS SHOWN IN FIGURE 1.
- J. REMOVE TWO NUTS, FOUR WASHERS, TWO SCREWS, AND BRACKET FROM FRONT CROSSMEMBER AS SHOWN IN FIGURE 1.

#### NOTE

PERFORM STEP K FOR VEHICLES WITH UNDERBODY PROTECTION KIT INSTALLED.

- K. REMOVE THREE NUTS, SIX WASHERS, THREE SCREWS, AND FRONT SKID PLATE FROM FRONT SHIELD AS SHOWN IN FIGURE 2.

#### NOTE

PERFORM STEPS L AND M FOR ALL M998A2 SERIES WITHOUT WINCH.

- L. REMOVE THREE NUTS, SCREWS, SIX WASHERS, AND RIGHT INNER MOUNTING BRACKET FROM FRAME RAIL AS SHOWN IN FIGURE 3.
- M. REMOVE THREE NUTS, SCREWS, SIX WASHERS, AND LEFT INNER MOUNTING BRACKET FROM FRAME RAIL AS SHOWN IN FIGURE 3.
- N. REMOVE RIGHT FRONT SUSPENSION BRACE. (REFER TO TM 9-2320-280-34.)

#### NOTE

FOR EASE OF INSTALLATION FOR WINCH AND BUMPER ASSEMBLY, INSTALL SCREW WITH ABOUT THREE THREADS THROUGH FRONT CROSSMEMBER.

- O. INSTALL EXISTING WASHER AND B1821BH075C550N SCREW IN RIGHT LOWER CONTROL ARM AND FRONT CROSSMEMBER AS SHOWN IN FIGURE 4.

<b>INSTALLATION INSTRUCTIONS, 10,500 LB HYDRAULIC WINCH ACCESSORY KIT 57K3541</b>	SIZE	CAGE CODE	<b>12469068</b>		
	<b>A</b>	<b>19207</b>	(AMG U1805)	02-10-09	REVISION LEVEL A SHEET 3

**NOTE**

PERFORM STEP P FOR ALL M998A2 SERIES.

- P. REMOVE TWO SCREWS, WASHERS, CALIPER, AND YOKE FROM ADAPTER AS SHOWN IN FIGURE 5. SUPPORT CALIPER AND YOKE.
- Q. REMOVE LEFT FRONT SUSPENSION BRACE. (REFER TO TM 9-2320-280-34.)

**NOTE**

FOR EASE OF INSTALLATION FOR WINCH AND BUMPER ASSEMBLY, INSTALL SCREW WITH ABOUT THREE THREADS THROUGH FRONT CROSSMEMBER.

- R. INSTALL EXISTING WASHER AND B1821BH075C550N SCREW IN LEFT LOWER CONTROL ARM AND FRONT CROSSMEMBER AS SHOWN IN FIGURE 4.

**NOTE**

PERFORM STEP S FOR ALL M998A2 SERIES.

- S. APPLY MIL-S-46163 SEALING COMPOUND TO THREADS OF TWO EXISTING SCREWS AND INSTALL CALIPER AND YOKE ON ADAPTER WITH TWO EXISTING WASHERS AND SCREWS AS SHOWN IN FIGURE 5.
- T. REMOVE WINCH VENT LINE, IF APPLICABLE. (REFER TO TM 9-2320-280-20.)

**NOTE**

PERFORM STEPS U AND V FOR VEHICLES THAT HAD WINCH VENT LINES.

- U. REMOVE UNION TEE AND TUBE FROM FRONT VENT LINE UNION TEE AND AIR CLEANER VENT LINE AS SHOWN IN FIGURE 6.
- V. CONNECT AIR CLEANER VENT LINE TO UNION TEE ON FRONT VENT LINE AS SHOWN IN FIGURE 6.

**3-2. WINCH INSTALLATION.**

- A. INSTALL 12469393-1 SUPPORT BRACKET TO FRAME RAIL WITH THREE B1821BH063C400N SCREWS, SIX EXISTING WASHERS, 2436167 WASHER, 2436168 WASHER, AND THREE M45913/4-10CG8Z NUTS AS SHOWN IN FIGURE 7.
- B. INSTALL 12469393-2 SUPPORT BRACKET TO FRAME RAIL WITH THREE B1821BH063C400N SCREWS, SIX EXISTING WASHERS, 2436167 WASHER, 2436168 WASHER, AND THREE M45913/4-10CG8Z NUTS AS SHOWN IN FIGURE 7.

**WARNING**

WINCH AND BUMPER MUST BE SUPPORTED DURING INSTALLATION. FAILURE TO SUPPORT WINCH MAY RESULT IN INJURY TO PERSONNEL OR DAMAGE TO EQUIPMENT.

- C. POSITION 12469358 WINCH AND BUMPER ON LEFT AND RIGHT LOWER CONTROL ARM SCREWS B1821BH075C550N, PUSH SCREWS THROUGH BUMPER, AND SECURE WITH EXISTING WASHERS AND M45913/4-12CG8Z NUTS AS SHOWN IN FIGURE 8. DO NOT TIGHTEN NUTS.
- D. SECURE BUMPER AND TWO EXISTING TOW BRACKETS TO LEFT AND RIGHT SUPPORT BRACKETS WITH FOUR EXISTING SCREWS, EIGHT WASHERS, AND FOUR M45913/4-8CG8Z NUTS AS SHOWN IN FIGURE 8.

INSTALLATION INSTRUCTIONS, 10,500 LB HYDRAULIC WINCH ACCESSORY KIT 57K3541	SIZE	CAGE CODE	12469068		
	A	19207			
(AMG U1805)		02-10-09	REVISION LEVEL	A	SHEET 4

E. TIGHTEN NUTS INSTALLED IN STEP C AS SHOWN IN FIGURE 8.

**NOTE**

PERFORM STEP F FOR VEHICLES WITH UNDERBODY PROTECTION INSTALLED.

F. SECURE FRONT SHIELD TO BUMPER WITH THREE B1821BH038C175N SCREWS, 12469395 SPACERS, SIX EXISTING WASHERS, AND THREE M45913/4-6CG8Z NUTS AS SHOWN IN FIGURE 9.

**NOTE**

PERFORM STEPS G THROUGH I FOR ALL M998A2 SERIES WITH BRAKE PROTECTION GUARDS.

G. INSTALL 12460270-1 BRACKET ON FRONT INTERMEDIATE CROSSMEMBER WITH EXISTING SCREW, TWO WASHERS, AND M45913/4-6CG8Z NUT AS SHOWN IN FIGURE 10.

H. SECURE LEFT AND RIGHT BRAKE PROTECTION GUARDS TO BUMPER WITH THREE B1821BH038C175N SCREWS, 12469395 SPACERS, SIX EXISTING WASHERS, AND THREE M45913/4-6CG8Z NUTS AS SHOWN IN FIGURE 10.

I. SECURE LEFT BRAKE PROTECTION GUARD TO BRACKET WITH EXISTING SCREW, TWO WASHERS, AND M45913/4-6CG8Z NUT AS SHOWN IN FIGURE 10.

**3-3. WINCH ELECTRICAL INSTALLATION.**

A. OPEN HOOD. (REFER TO TM 9-2320-280-10.)

B. INSTALL 8741492 CONNECTOR TO MS27147-1 ADAPTER AS SHOWN IN FIGURE 11.

**NOTE**

PERFORM STEPS C THROUGH E FOR M998 AND M998A2 SERIES EXCEPT M1097 VEHICLES.

C. DISCONNECT LEAD 458A FROM LEAD 458 AS SHOWN IN FIGURE 11.

D. CONNECT LEAD 458 TO CONNECTOR AS SHOWN IN FIGURE 11.

E. CONNECT LEAD 458A TO ADAPTER AS SHOWN IN FIGURE 11.

**NOTE**

PERFORM STEPS F THROUGH H FOR M998A1 SERIES AND M1097 VEHICLES.

F. DISCONNECT LEAD 458D FROM LEAD 458 AS SHOWN IN FIGURE 11.

G. CONNECT LEAD 458 TO CONNECTOR AS SHOWN IN FIGURE 11.

H. CONNECT LEAD 458D TO ADAPTER AS SHOWN IN FIGURE 11.

I. USING AA55571/01-001 CIRCUIT BREAKER AS A TEMPLATE, LOCATE AND MARK TWO HOLE LOCATIONS ON LEFT TOP COWL AS SHOWN IN FIGURE 12. REMOVE CIRCUIT BREAKER.

J. DRILL TWO 0.136-INCH DIAMETER HOLES IN LEFT TOP COWL MARKED IN STEP I AS SHOWN IN FIGURE 12.

K. SECURE CIRCUIT BREAKER TO LEFT TOP COWL WITH TWO 449617 SCREWS AS SHOWN IN FIGURE 12.

L. CONNECT 12469065-1 LEAD WIRE LEAD 458/785B TO ADAPTER AND LEAD 785B TO CIRCUIT BREAKER AS SHOWN IN FIGURES 11 AND 12.

**INSTALLATION INSTRUCTIONS,  
10,500 LB HYDRAULIC WINCH  
ACCESSORY KIT 57K3541**

SIZE

**A**

CAGE CODE

**19207**

**12469068**

(AMG U1805)

02-10-09

REVISION LEVEL

**A**

SHEET 5



- M. SECURE LEAD WIRE TO ENGINE HARNESS WITH FOUR MS3367-1-0 TIEDOWN STRAPS AS SHOWN IN FIGURE 11.
- N. CONNECT 12469065-2 LEAD WIRE LEAD 785B TO CIRCUIT BREAKER AND ROUTE UNDER HYDRAULIC HOSES, BETWEEN FUEL DRAIN HOSE AND LEFT INNER COWL, AND BODY WIRING HARNESS TO WINCH AS SHOWN IN FIGURE 13.
- O. LOCATE, MARK, AND DRILL 0.937-INCH DIAMETER HOLE IN BODY PANEL AS SHOWN IN FIGURE 14.

**CAUTION**

ENSURE CONTROLLER PLUG DOES NOT CONTACT ANY MOVING PARTS.

- P. ROUTE 12469064 CONTROLLER PLUG THROUGH HOLE IN BODY PANEL, DRILLED IN STEP O, AROUND FUEL FILTER, ALONG BODY WIRING HARNESS, UNDER STEERING SHAFT, TO FRAME RAIL AND BODY WIRING HARNESS TO WINCH AS SHOWN IN FIGURE 15.
- Q. USING CONTROLLER PLUG AS A TEMPLATE, DRILL 0.089-INCH DIAMETER HOLE IN BODY PANEL AND SECURE CONTROLLER PLUG WITH BLIND SPLINE AT TOP TO BODY PANEL WITH 9406088 SCREW AS SHOWN IN FIGURE 16.
- R. USING CONTROLLER PLUG AS A TEMPLATE, DRILL THREE REMAINING 0.089-INCH DIAMETER HOLES IN BODY PANEL AND SECURE CONTROLLER PLUG, CAP, AND CHAIN TO BODY PANEL WITH THREE 9406088 SCREWS AS SHOWN IN FIGURE 16.

**3-4. HYDRAULIC HOSE INSTALLATION.**

- A. LOOSEN INLET AND OUTLET BANJO FITTINGS ON WINCH MOTOR AS SHOWN IN FIGURE 21.
- B. ROUTE 12469392-4 HOSE ASSEMBLY BETWEEN HYDRO-BOOST AND MASTER CYLINDER OVER POWER STEERING GEAR AND DIFFERENTIAL TO WINCH INLET PORT AS SHOWN IN FIGURE 17.

**NOTE**

ENSURE AREA AROUND HYDRO-BOOST PORT IS CLEAN BEFORE REMOVING POWER STEERING HOSE.

- C. DISCONNECT POWER STEERING HOSE FROM HYDRO-BOOST AND REMOVE O-RING AS SHOWN IN FIGURE 17.

**NOTE**

LUBRICATE O-RING PRIOR TO INSTALLATION.

- D. REMOVE O-RING FROM HOSE ASSEMBLY 12469392-4, LUBRICATE O-RING WITH DEXRON® III, INSTALL ON HOSE ASSEMBLY 12469392-4 AND CONNECT HOSE TO HYDRO-BOOST AS SHOWN IN FIGURE 17.
- E. ROUTE 12469392-3 HOSE ASSEMBLY ALONG SIDE HOSE ASSEMBLY 12469392-4 TO WINCH AND CONNECT TO OUTLET PORT ON WINCH AS SHOWN IN FIGURE 18.

**NOTE**

ENSURE AREA AROUND POWER STEERING GEAR PORT IS CLEAN BEFORE REMOVING POWER STEERING HOSE.

- F. REMOVE POWER STEERING HOSE AND O-RING FROM POWER STEERING GEAR AS SHOWN IN FIGURE 18.

<b>INSTALLATION INSTRUCTIONS, 10,500 LB HYDRAULIC WINCH ACCESSORY KIT 57K3541</b>	SIZE <b>A</b>	CAGE CODE <b>19207</b>	<b>12469068</b>		
	(AMG U1805)	02-10-09	REVISION LEVEL	A	SHEET 6

**NOTE**

**LUBRICATE O-RING PRIOR TO INSTALLATION.**

- G. REMOVE O-RING FROM HOSE ASSEMBLY 12469392-3, LUBRICATE O-RING WITH DEXRON® III, INSTALL ON HOSE ASSEMBLY 12469392-3 AND CONNECT HOSE TO POWER STEERING GEAR AS SHOWN IN FIGURE 18.
- H. TIGHTEN INLET AND OUTLET BANJO FITTINGS ON WINCH MOTOR TO 35 LB-FT AS SHOWN IN FIGURE 21.
- I. INSTALL 12469066 DECAL ON BODY PANEL AS SHOWN IN FIGURE 19.
- J. INSTALL 12469067 DECAL ON FAIRLEAD BRACKET AS SHOWN IN FIGURE 20.

**3-5. FINAL PREPARATION.**

- A. CONNECT LEAD WIRE 12469065-2 LEAD 785B TO CONTROLLER PLUG LEAD 785B AS SHOWN IN FIGURE 21.
- B. CONNECT CONTROLLER PLUG LEAD 785A TO WINCH LEAD 785A AS SHOWN IN FIGURE 21.
- C. CONNECT CONTROLLER PLUG LEAD 785C TO WINCH LEAD 785C AS SHOWN IN FIGURE 21.
- D. SECURE WINCH LEADS, CONTROLLER PLUG LEADS, AND LEAD WIRE TO BODY WIRING HARNESS ON FRONT CROSSMEMBER WITH TWO MS3367-1-0 TIEDOWN STRAPS AS SHOWN IN FIGURE 22.
- E. SECURE LEAD WIRE AND CONTROLLER PLUG TO BODY WIRING HARNESS WITH FIVE MS3367-7-0 TIEDOWN STRAPS AS SHOWN IN FIGURE 23.
- F. SECURE LEAD WIRE 12469065-2 TO BODY WIRING HARNESS ON LEFT INNER COWL WITH MS3367-1-0 TIEDOWN STRAP AS SHOWN IN FIGURE 24.
- G. SECURE CONTROLLER PLUG TO BODY WIRING HARNESS IN ENGINE COMPARTMENT WITH MS3367-7-0 TIEDOWN STRAP AS SHOWN IN FIGURE 24.
- H. CONNECT BATTERY GROUND CABLE. (REFER TO TM 9-2320-280-20.) (DO NOT INSTALL BATTERY BOX COVER.)
- I. REMOVE CAP ON CONTROLLER PLUG CONNECTOR AND CONNECT 12469356-1 SWITCH ASSEMBLY CONNECTOR TO CONTROLLER PLUG CONNECTOR AS SHOWN IN FIGURE 25.
- J. FILL POWER STEERING RESERVOIR, START ENGINE AND CHECK FOR LEAKS. STOP ENGINE, CHECK POWER STEERING RESERVOIR, FILL AS NECESSARY.

**CAUTION**

**DO NOT MOVE WINCH LEVERS WITH LOAD ON WINCH OR POWERING WINCH IN OR OUT.**

- K. START ENGINE, PLACE WINCH LEVERS IN LOW RANGE AND PAY OUT 5 TO 10 FEET OF WINCH CABLE AS SHOWN IN FIGURE 26.
- L. STOP ENGINE AND TURN WHEELS ALL THE WAY TO THE LEFT.
- M. FILL POWER STEERING RESERVOIR TO FULL COLD LEVEL ON CAP. LEAVE CAP OFF.
- N. RAISE FRONT WHEELS OFF GROUND.
- O. TURN STEERING WHEEL LEFT AND RIGHT, HOLDING WHEELS AT STEERING STOPS FOR FIVE SECONDS, FOR AT LEAST FORTY TIMES.

**INSTALLATION INSTRUCTIONS,  
10,500 LB HYDRAULIC WINCH  
ACCESSORY KIT 57K3541**

SIZE

**A**

CAGE CODE

**19207**

**12469068**

(AMG U1805)

02-10-09

REVISION LEVEL

**A**

SHEET 7

**NOTE**

- POWER STEERING FLUID MUST BE FREE OF BUBBLES AND FOAM. IF BUBBLES OR FOAM ARE NOTED, IT COULD BE AN INDICATION OF A LOOSE CONNECTION OR LEAKY O-RING.
- FLUID WITH AIR IN IT WILL HAVE A MILKY APPEARANCE. AIR MUST BE ELIMINATED FROM SYSTEM BEFORE NORMAL STEERING ACTION CAN BE OBTAINED.

- P. CHECK POWER STEERING RESERVOIR LEVEL. IF ANY BUBBLES ARE SEEN, REPEAT STEP O.
- Q. START ENGINE AND WITH ENGINE IDLING, ADD POWER STEERING FLUID IF NECESSARY. INSTALL CAP ON RESERVOIR.
- R. TURN WHEELS TO CENTER, SHUT OFF ENGINE, AND LOWER FRONT WHEELS TO GROUND.
- S. START ENGINE AND RUN ENGINE FOR TWO OR THREE MINUTES, TURNING WHEELS LEFT AND RIGHT.
- T. PLACE WINCH LEVERS IN FREE SPOOL AND PAY OUT WINCH CABLE UNTIL FIVE WRAPS OF CABLE ARE LEFT ON WINCH DRUM AS SHOWN IN FIGURE 26.

**CAUTION**

DO NOT MOVE WINCH LEVERS WITH LOAD ON WINCH OR POWERING WINCH IN OR OUT.

**NOTE**

ENSURE TO MAINTAIN APPROXIMATELY 500 LB LOAD OR HIGHER TENSION ON WINCH CABLE WHILE PAYING IN.

- U. PLACE WINCH LEVERS IN LOW RANGE AND PAY IN WINCH CABLE AND ENSURE WINCH CABLE STAYS TIGHT AS SHOWN IN FIGURE 26. STOP ENGINE.
- V. DISCONNECT SWITCH ASSEMBLY CONNECTOR FROM CONTROLLER PLUG CONNECTOR AS SHOWN IN FIGURE 25. INSTALL CAP ON CONTROLLER PLUG CONNECTOR.

**NOTE**

USE TUBE ASSEMBLY TO CONNECT HOSES (12469392-4 AND 12469392-3) WHEN WINCH IS REMOVED.

- W. POSITION SWITCH ASSEMBLY, 12469357 TUBE ASSEMBLY, 12469394 STRAP, AND 12469355 SNATCH BLOCK IN STOWAGE BOX UNDER COMMANDER'S (COMPANION) SEAT AS SHOWN IN FIGURE 27.
- X. INSTALL COMMANDER'S (COMPANION) SEAT. (REFER TO TM 9-2320-280-20.)

**NOTE**

PERFORM STEP R FOR VEHICLES THAT HAD 6,000 OR 9,000 LB ELECTRIC WINCHES.

- Y. APPLY 737RTV SEALING COMPOUND TO STARTER POSITIVE AND NEGATIVE STUDS AND CONNECTING LEADS.

INSTALLATION INSTRUCTIONS, 10,500 LB HYDRAULIC WINCH ACCESSORY KIT 57K3541	SIZE	CAGE CODE	12469068	
	A	19207		
(AMG U1805)	02-10-09	REVISION LEVEL	A	SHEET 8

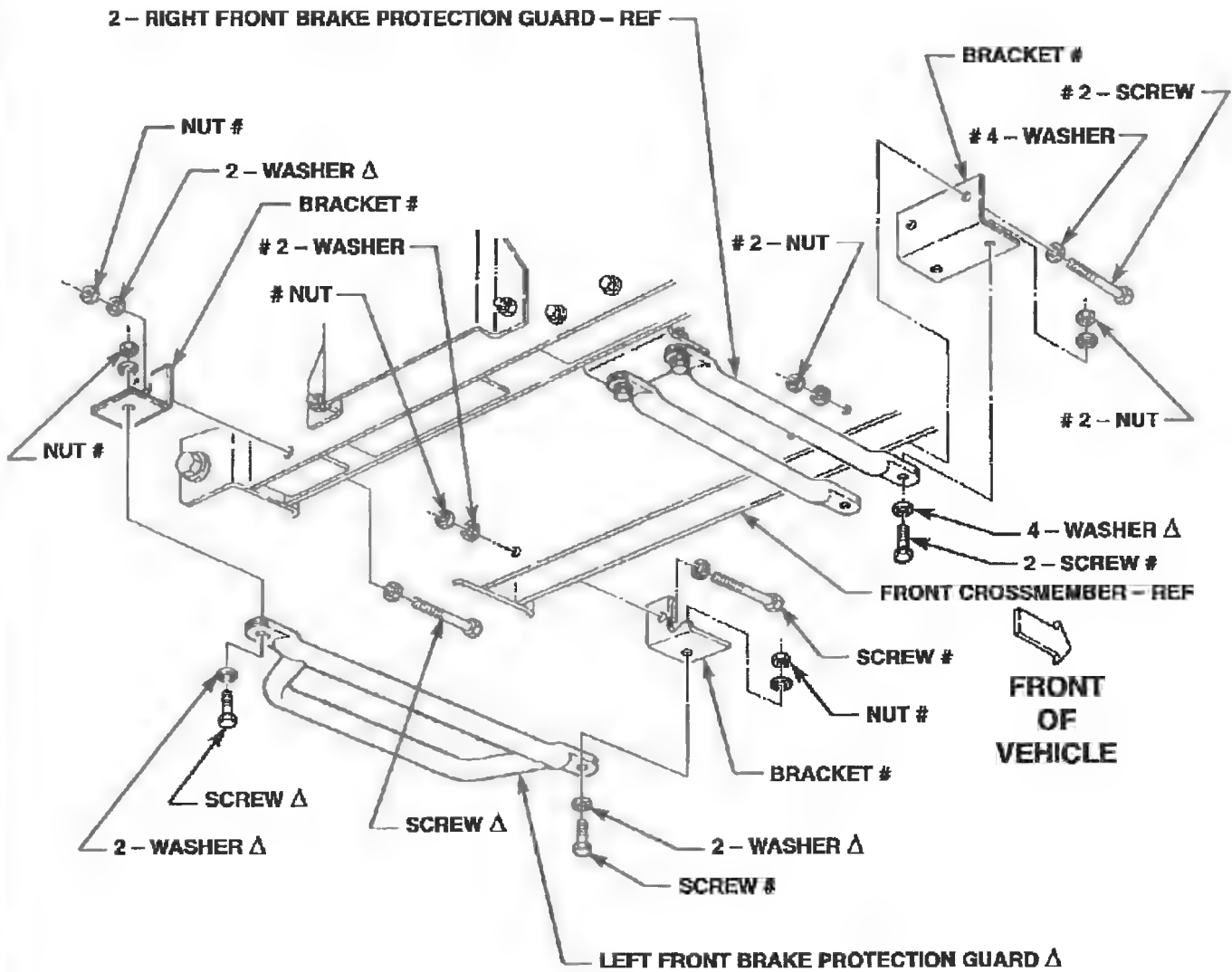

FIGURE 1

INSTALLATION INSTRUCTIONS,  
10,500 LB HYDRAULIC WINCH  
ACCESSORY KIT 57K3541

SIZE

A

CAGE CODE

19207

12469068

(AMG U1805)

02-10-09

REVISION LEVEL

A

SHEET 9

# FRONT SKID PLATE

# 3 - NUT

FRONT SHIELD - REF

Δ 6 - WASHER

# 3 - SCREW

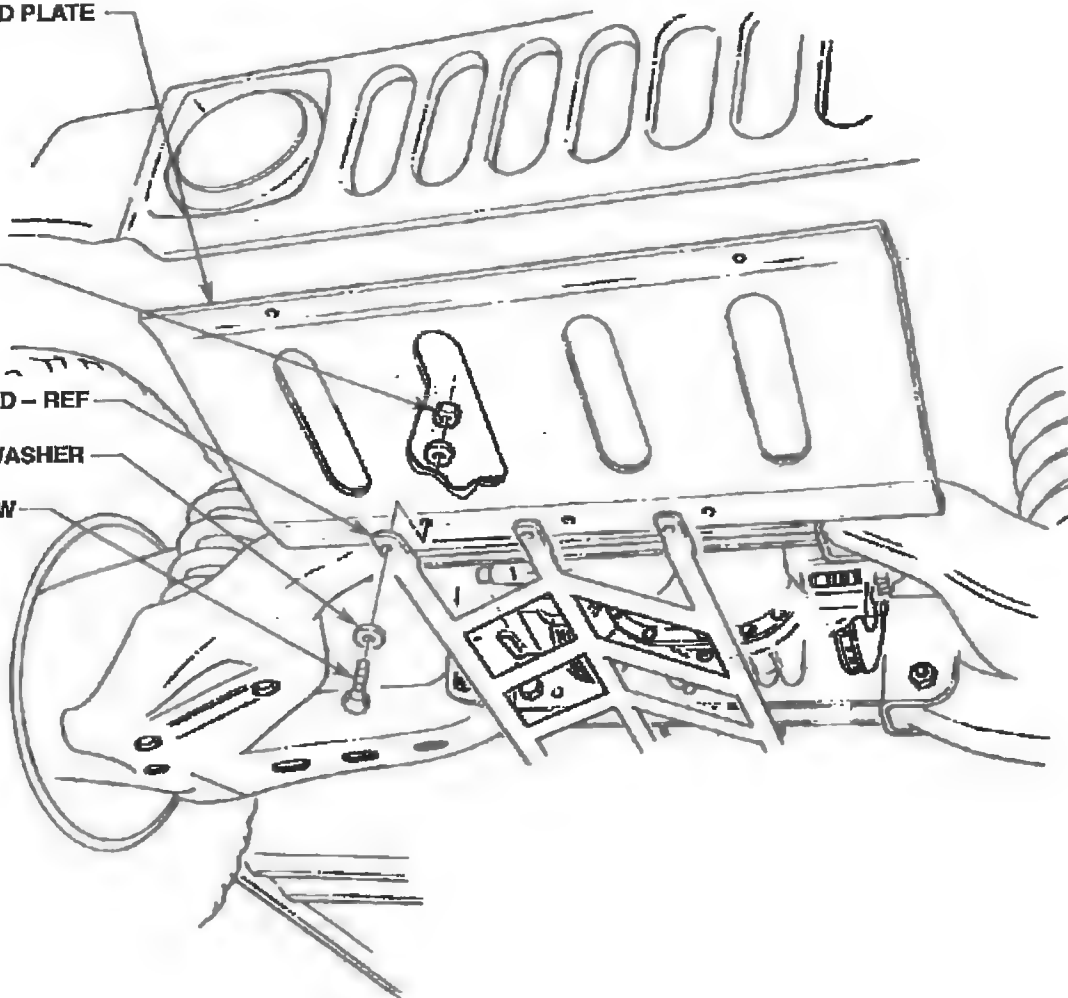

FIGURE 2

INSTALLATION INSTRUCTIONS,  
10,500 LB HYDRAULIC WINCH  
ACCESSORY KIT 57K3541

SIZE

A

CAGE CODE

19207

12469068

(AMG U1805)

02-10-09

REVISION LEVEL

A

SHEET 10

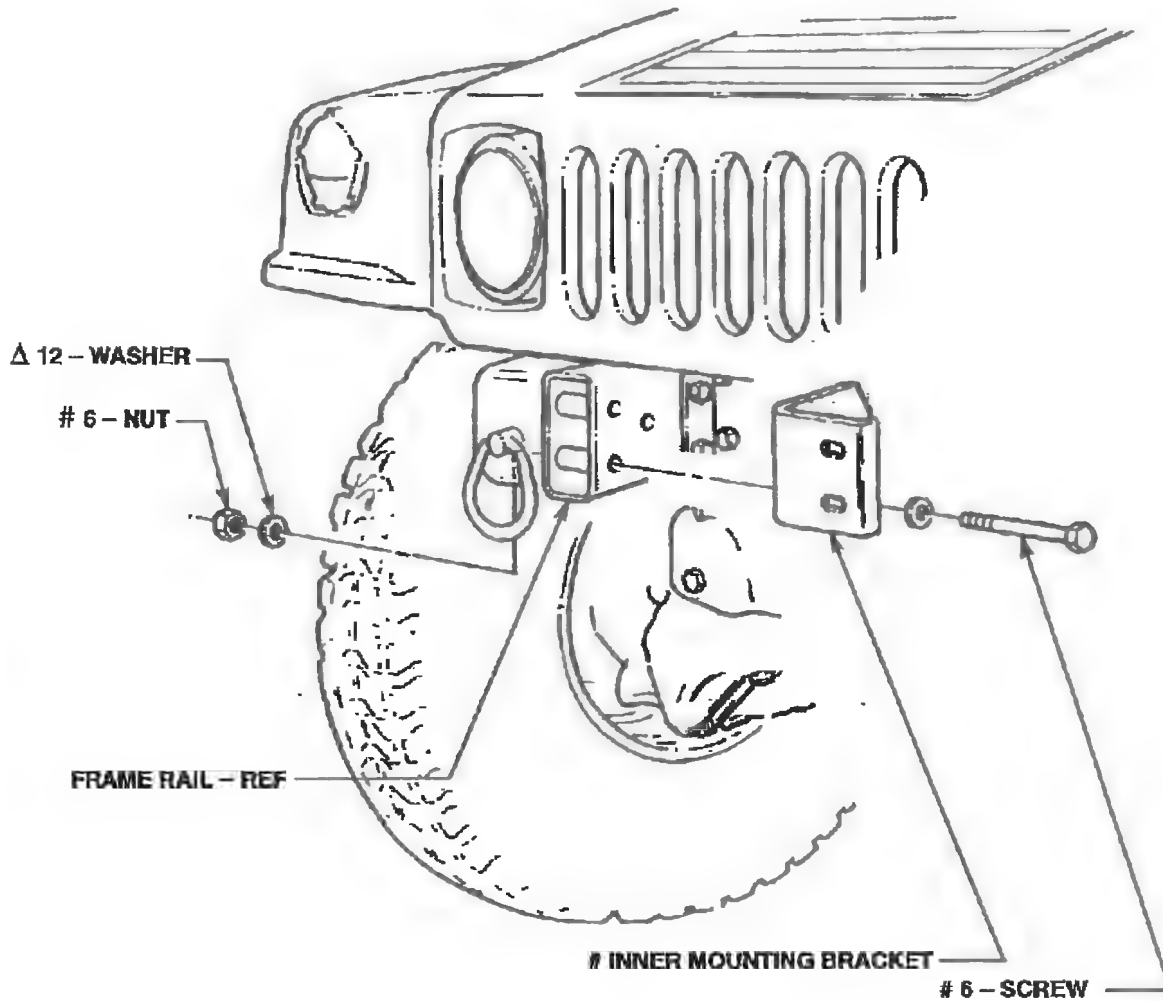

RIGHT SIDE SHOWN, LEFT SIDE OPPOSITE

FIGURE 3

INSTALLATION INSTRUCTIONS,  
10,500 LB HYDRAULIC WINCH  
ACCESSORY KIT 57K3541

SIZE

A

CAGE CODE

19207

12469068

(AMG U1805)

02-10-09

REVISION LEVEL

A

SHEET 11

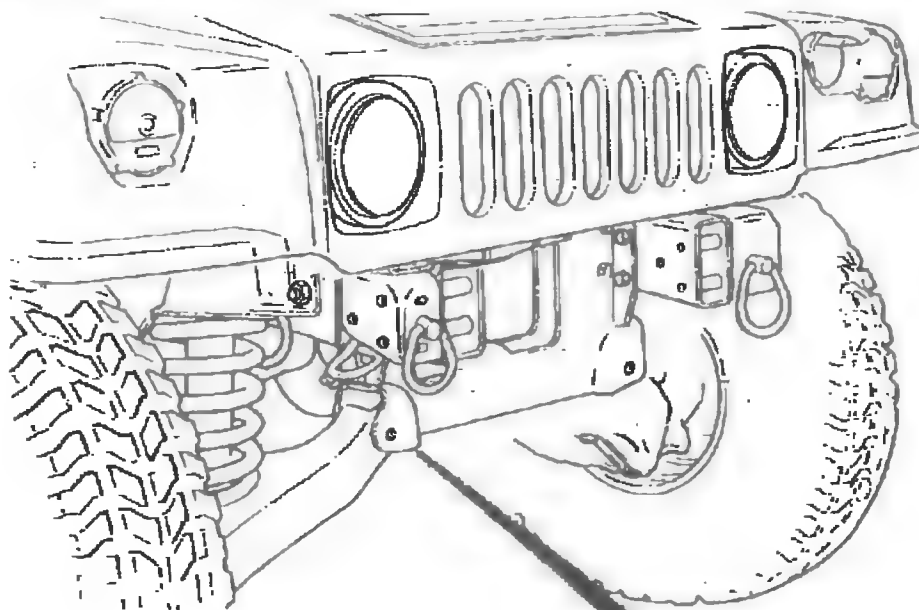

Δ 2 - WASHER  
 RIGHT LOWER CONTROL ARM - REF

\* 2 - SCREW - B1821BH075C550N

FRONT CROSSMEMBER - REF

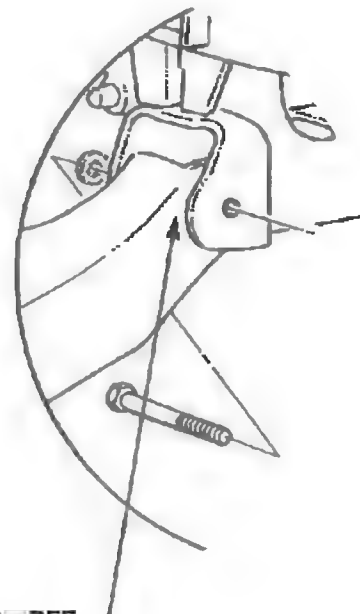

RIGHT SIDE SHOWN, LEFT SIDE OPPOSITE

**FIGURE 4**

**INSTALLATION INSTRUCTIONS,  
 10,500 LB HYDRAULIC WINCH  
 ACCESSORY KIT 57K3541**

SIZE

**A**

CAGE CODE

**19207**

**12469068**

(AMG U1805)

02-10-09

REVISION LEVEL A

SHEET 12

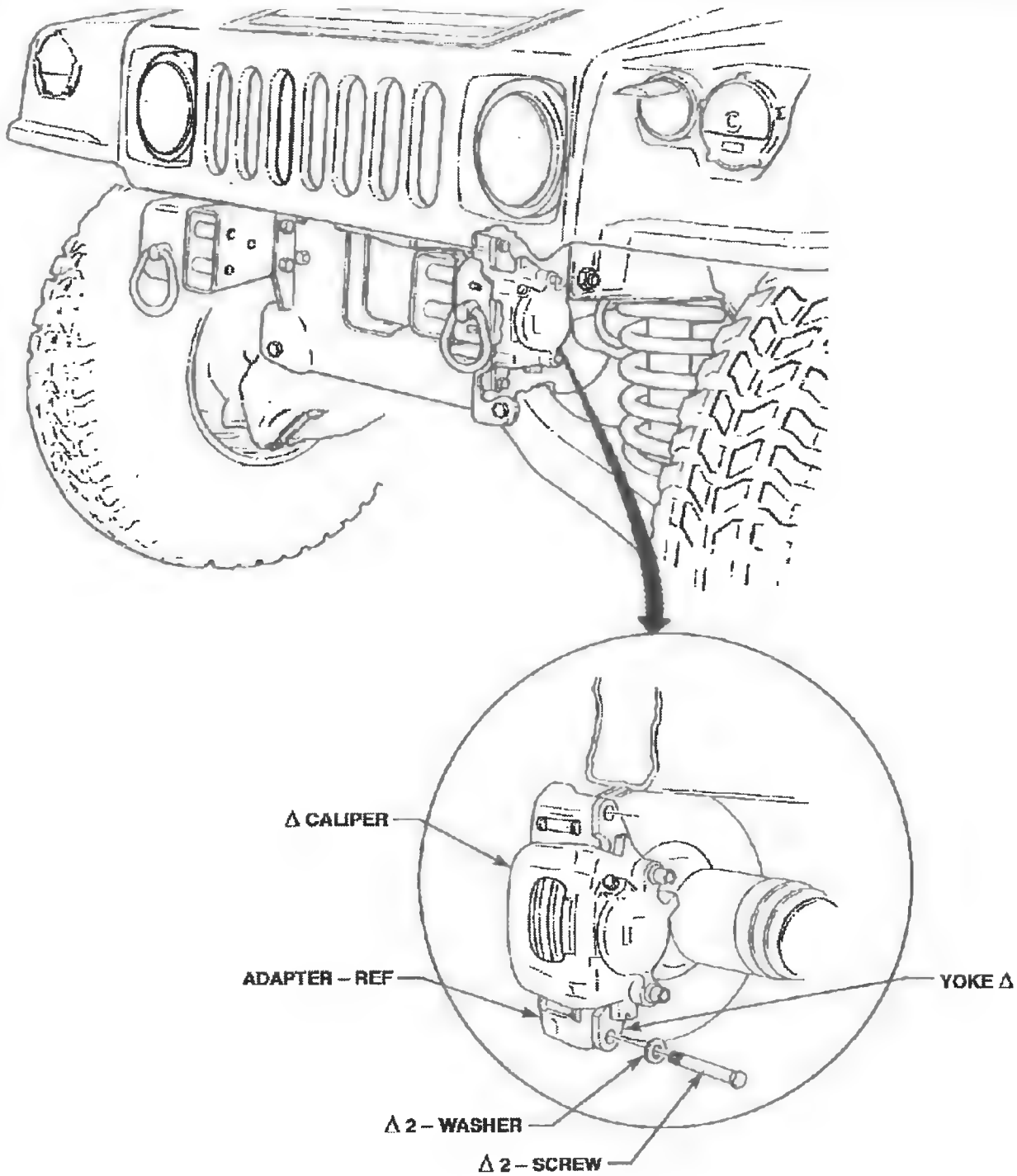

**FIGURE 5**

**INSTALLATION INSTRUCTIONS,  
 10,500 LB HYDRAULIC WINCH  
 ACCESSORY KIT 57K3541**

SIZE

**A**

CAGE CODE

**19207**

**12469068**

(AMG U1805)

02-10-09

REVISION LEVEL

**A**

SHEET 13



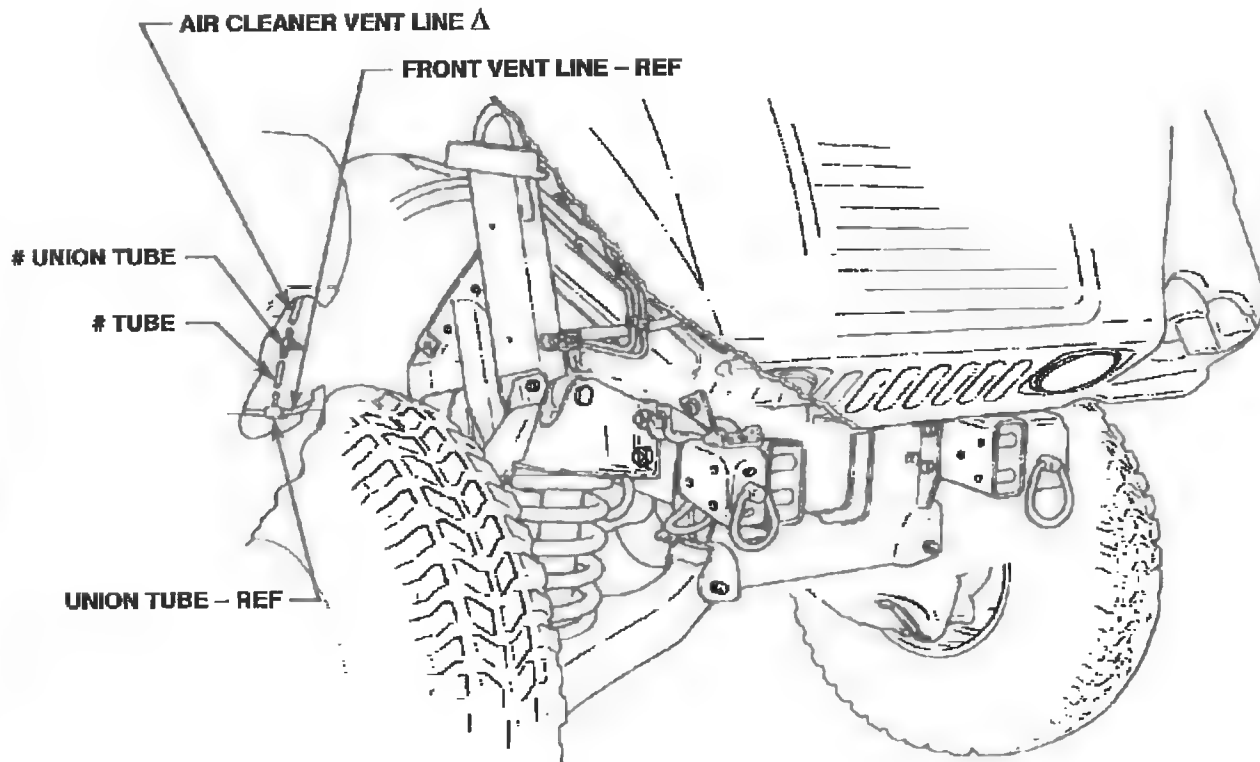

**FIGURE 6**

**INSTALLATION INSTRUCTIONS,  
10,500 LB HYDRAULIC WINCH  
ACCESSORY KIT 57K3541**

SIZE

**A**

CAGE CODE

**19207**

**12469068**

(AMG U1805)

02-10-09

REVISION LEVEL **A**

SHEET 14

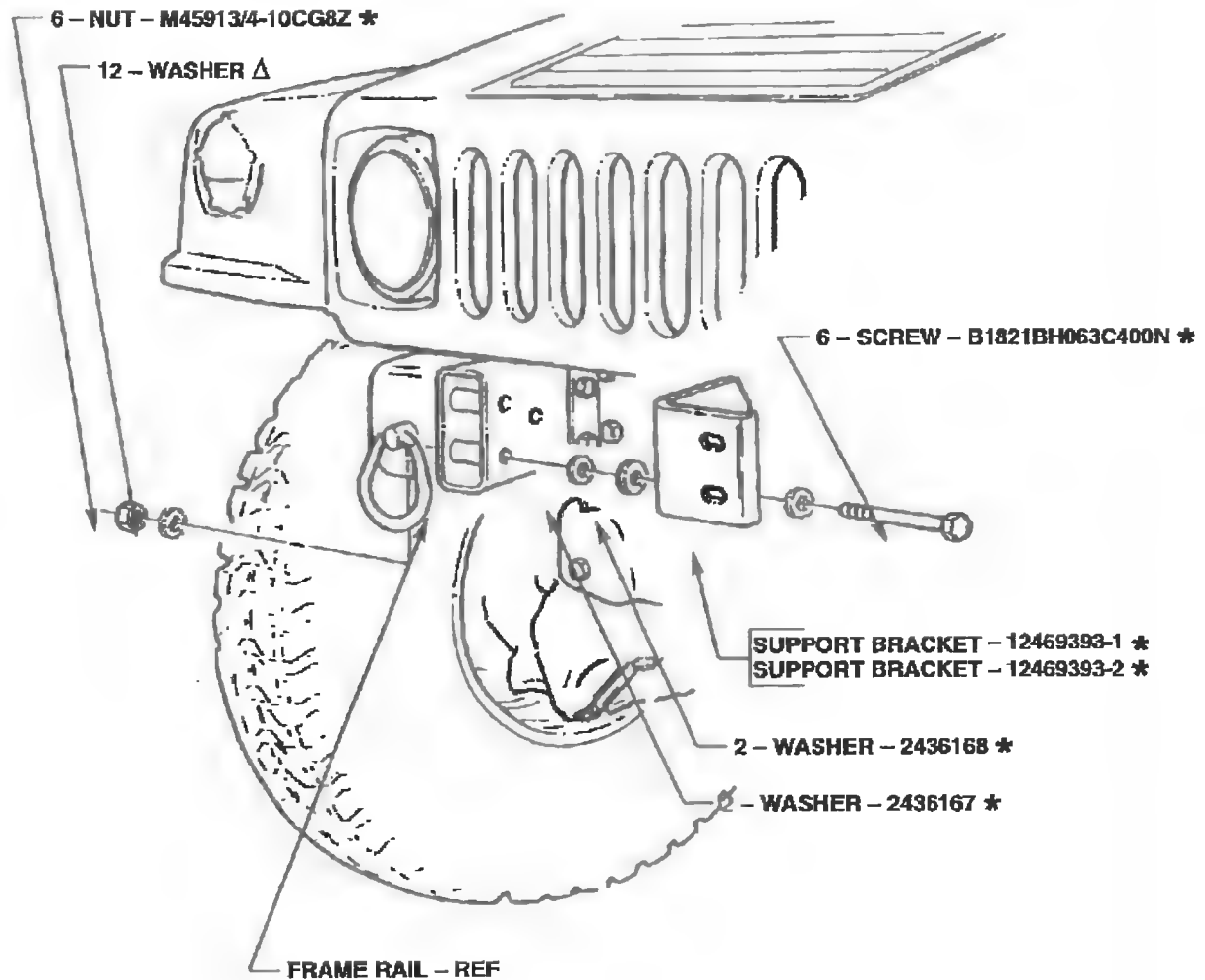

RIGHT SIDE SHOWN, LEFT SIDE OPPOSITE

**FIGURE 7**

**INSTALLATION INSTRUCTIONS,  
10,500 LB HYDRAULIC WINCH  
ACCESSORY KIT 57K3541**

SIZE  
**A**

CAGE CODE  
**19207**

**12469068**

(AMG U1805)

02-10-09

REVISION LEVEL

**A**

SHEET 15

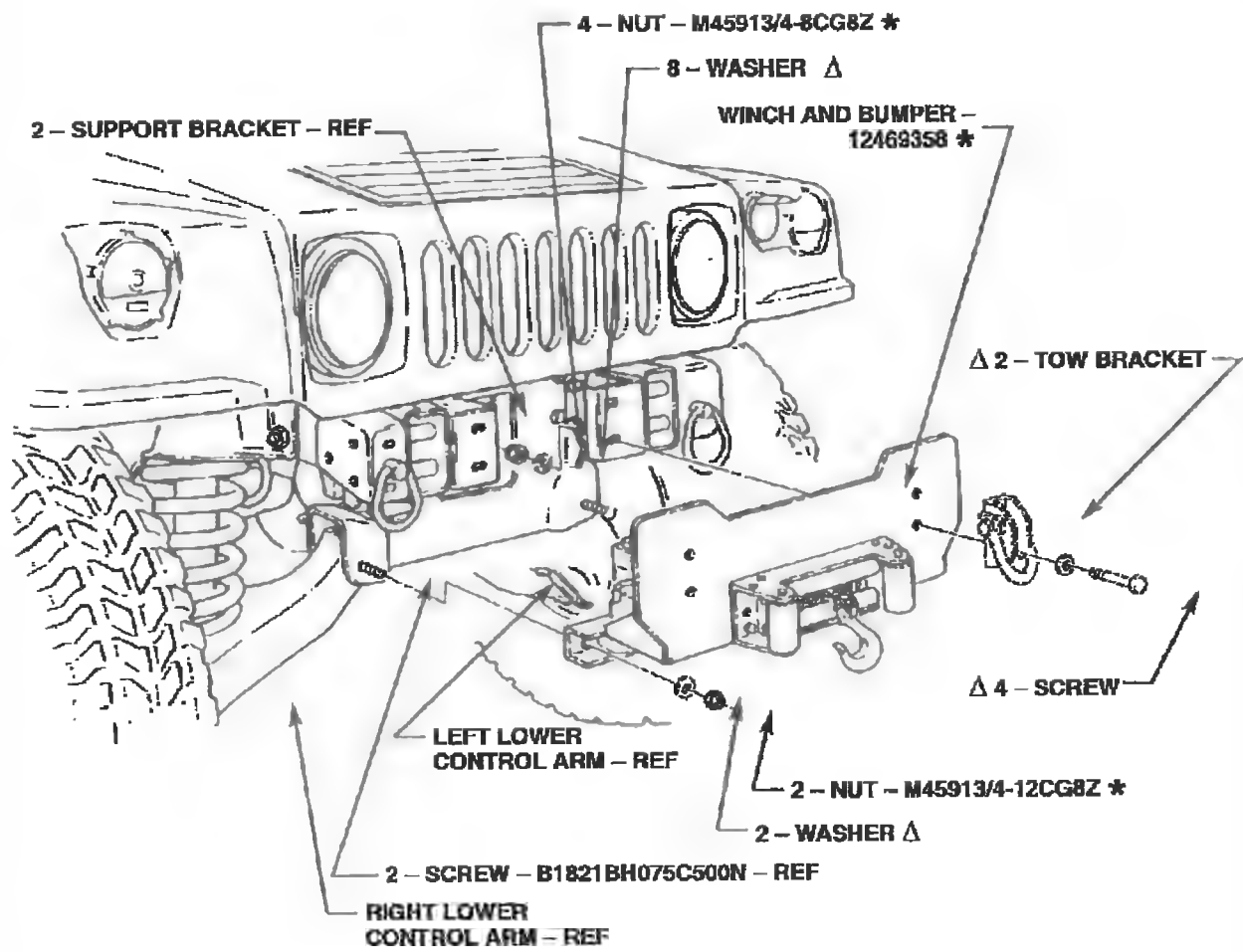

**FIGURE 8**

**INSTALLATION INSTRUCTIONS,  
10,500 LB HYDRAULIC WINCH  
ACCESSORY KIT 57K3541**

SIZE  
**A**

CAGE CODE  
**19207**

**12469068**

(AMG U1805)

02-10-09

REVISION LEVEL

**A**

SHEET 16

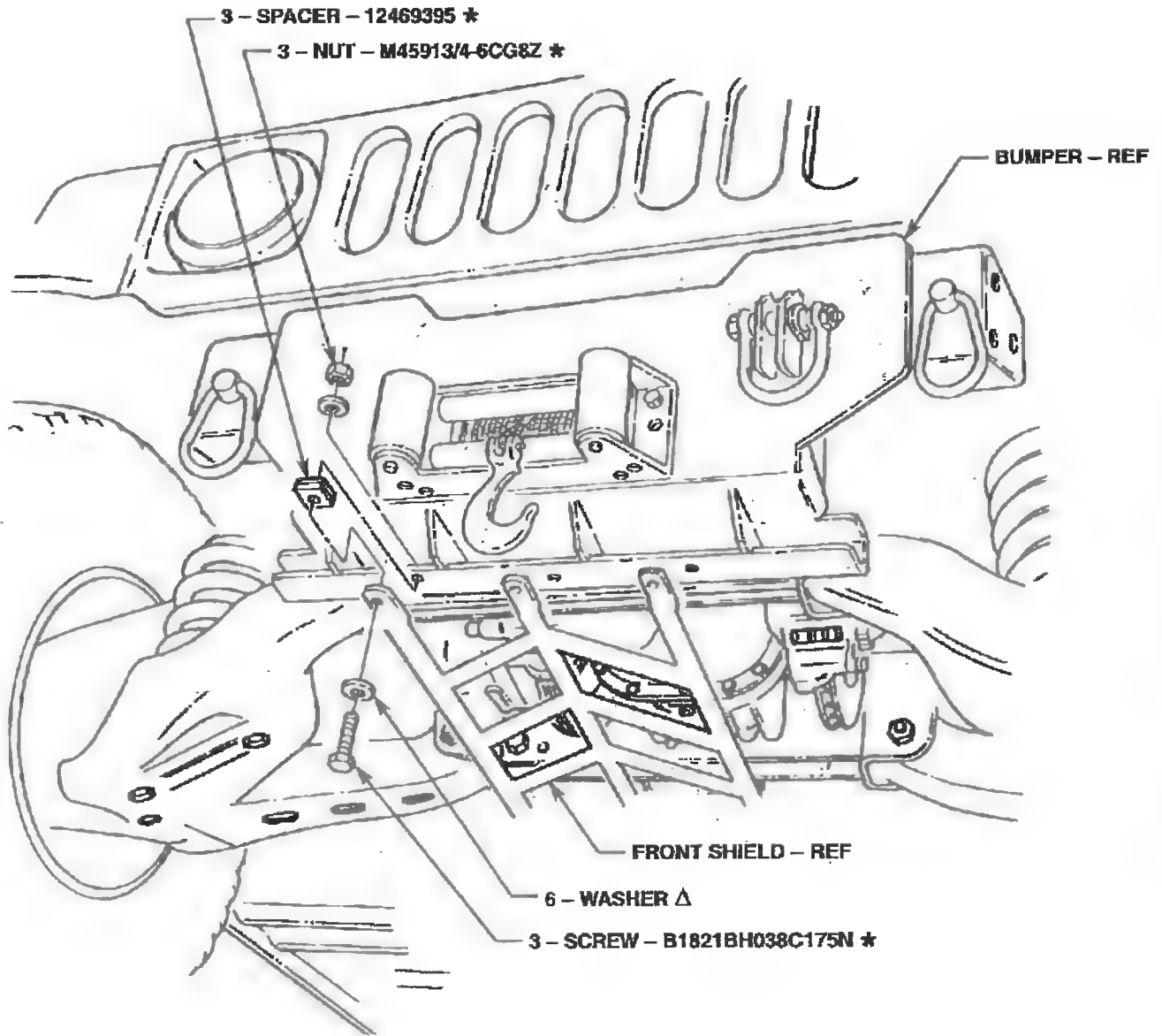

**FIGURE 9**

**INSTALLATION INSTRUCTIONS,  
10,500 LB HYDRAULIC WINCH  
ACCESSORY KIT 57K3541**

SIZE  
**A**

CAGE CODE  
**19207**

**12469068**

(AMG U1805)

02-10-09

REVISION LEVEL **A**

SHEET 17

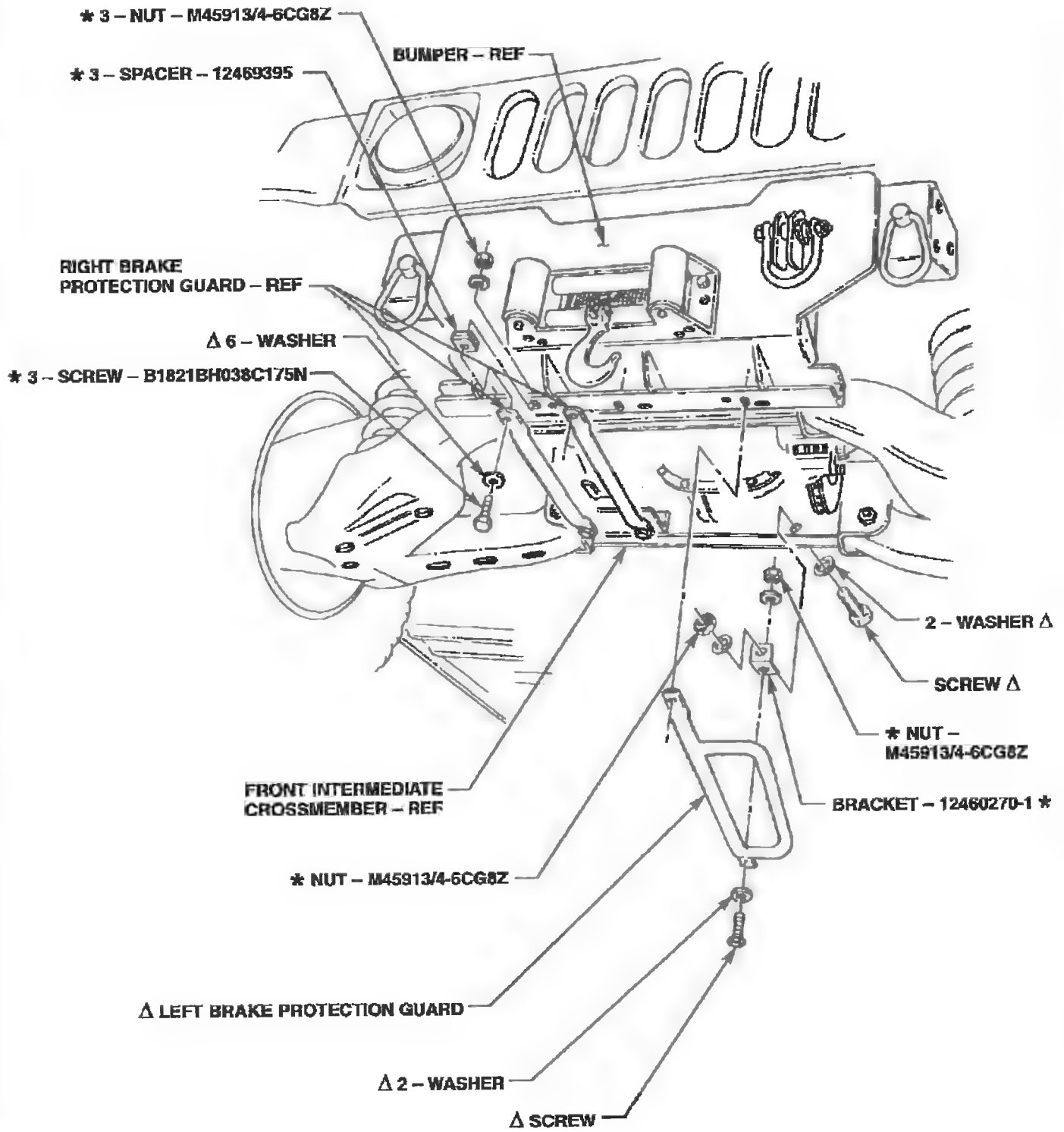

**FIGURE 10**

**INSTALLATION INSTRUCTIONS,  
10,500 LB HYDRAULIC WINCH  
ACCESSORY KIT 57K3541**

SIZE

**A**

CAGE CODE

**19207**

**12469068**

(AMG U1805)

02-10-09

REVISION LEVEL

**A**

SHEET 18

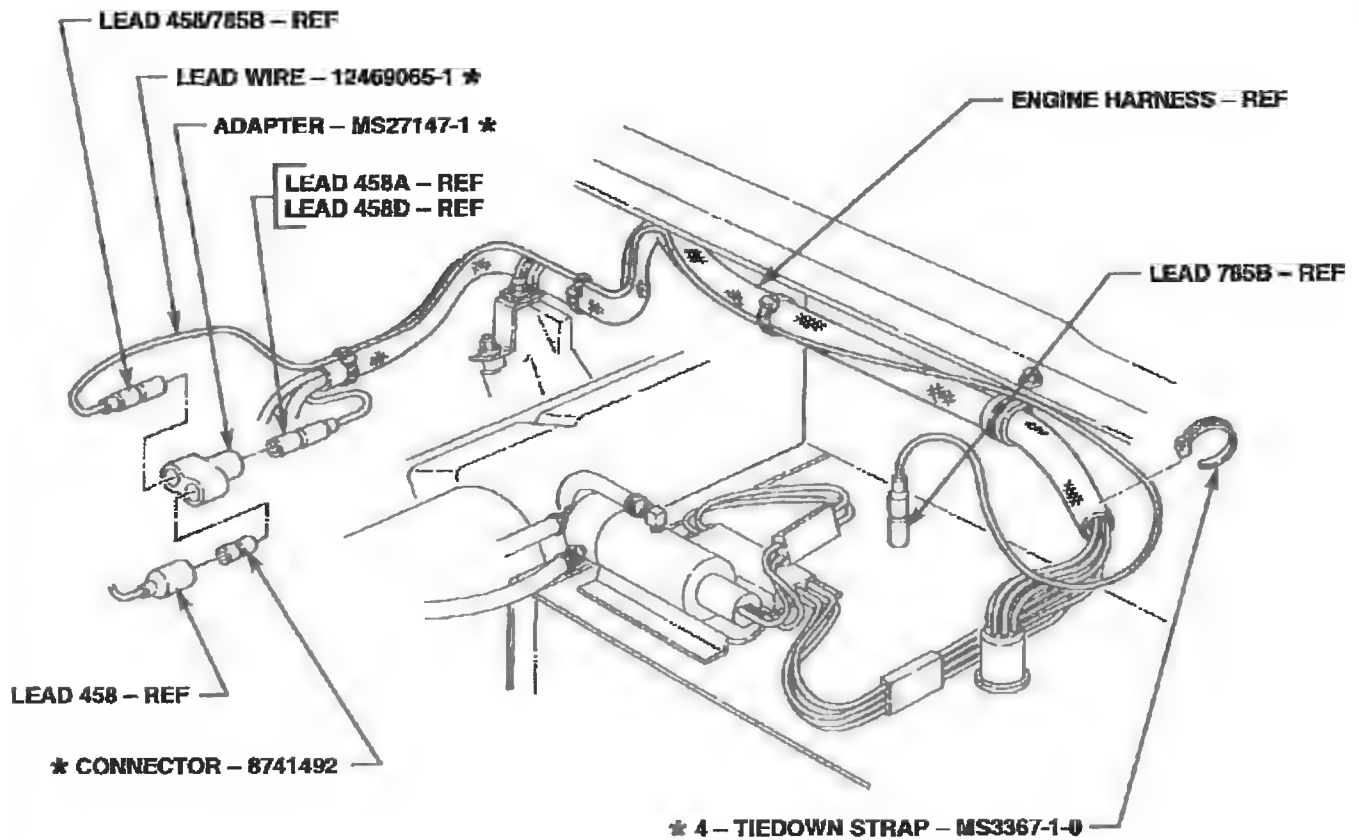

**FIGURE 11**

**INSTALLATION INSTRUCTIONS,  
10,500 LB HYDRAULIC WINCH  
ACCESSORY KIT 57K3541**

SIZE

**A**

CAGE CODE

**19207**

**12469068**

(AMG U1805)

02-10-09

REVISION LEVEL

**A**

SHEET 19

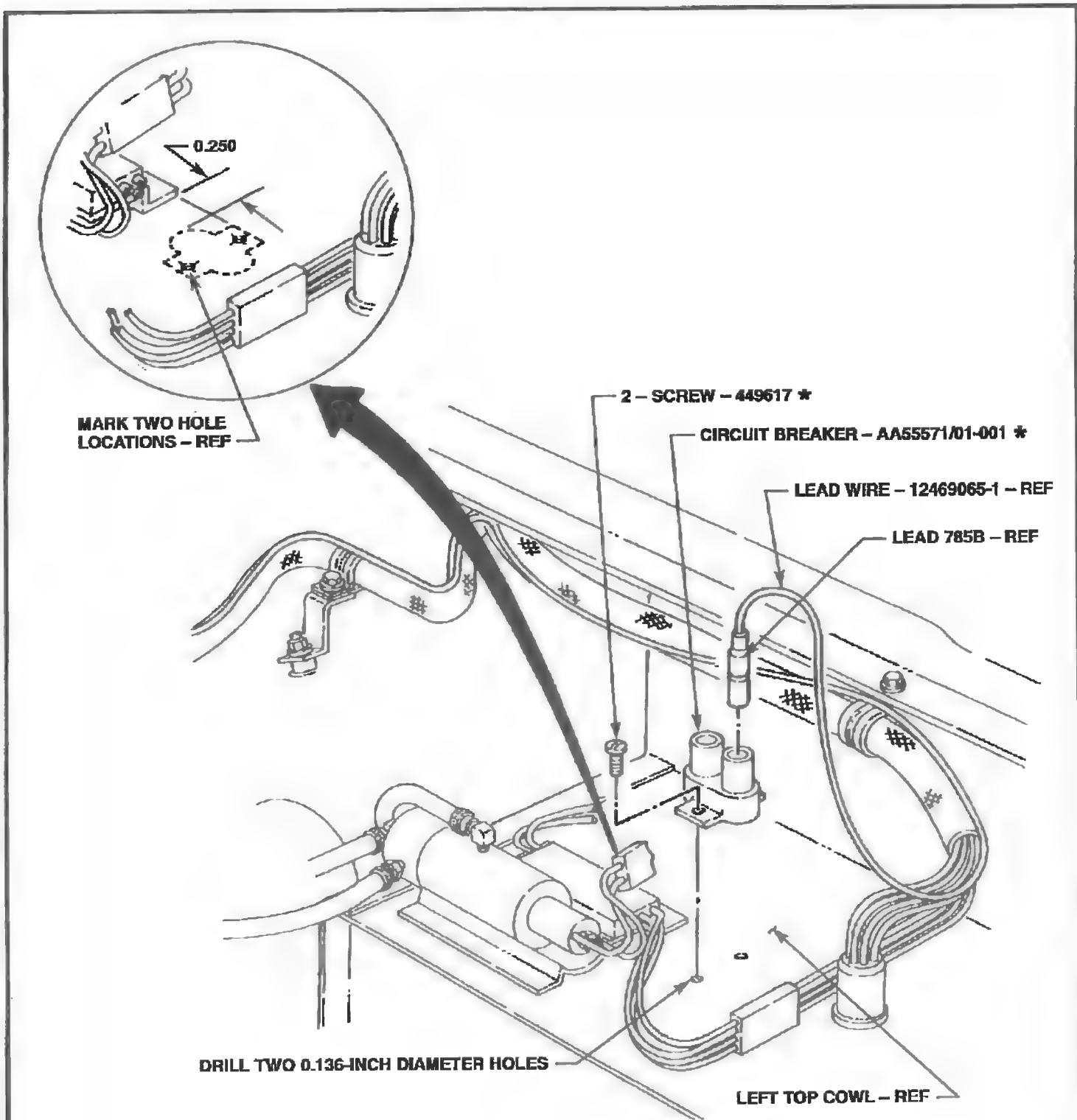

**FIGURE 12**

<b>INSTALLATION INSTRUCTIONS, 10,500 LB HYDRAULIC WINCH ACCESSORY KIT 57K3541</b>	SIZE <b>A</b>	CAGE CODE <b>19207</b>	<b>12469068</b>	
	(AMG U1805)	02-10-09	REVISION LEVEL <b>A</b>	SHEET 20

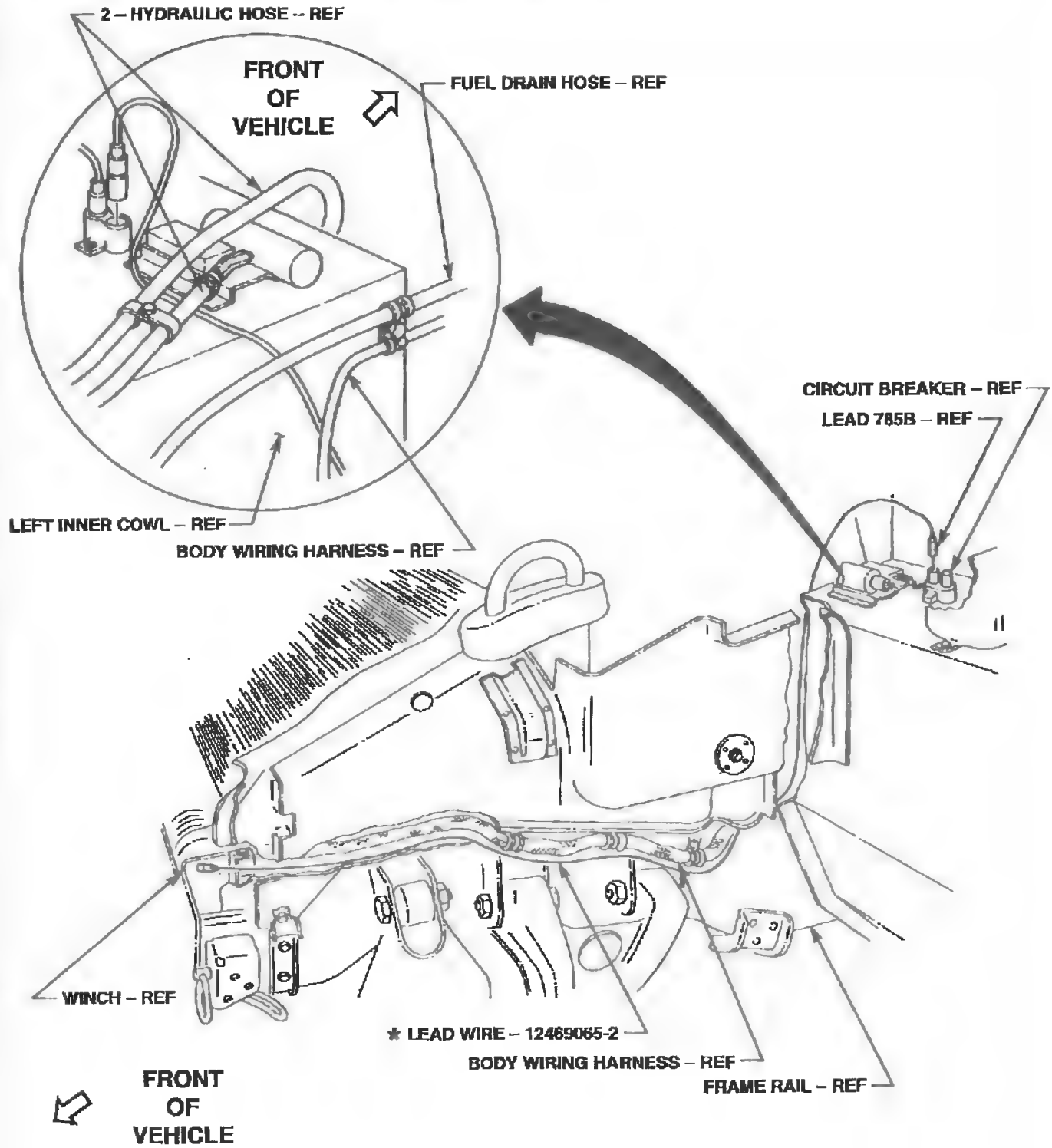

FIGURE 13

INSTALLATION INSTRUCTIONS,  
10,500 LB HYDRAULIC WINCH  
ACCESSORY KIT 57K3541

SIZE

A

CAGE CODE

19207

12469068

(AMG U1805)

02-10-09

REVISION LEVEL

A

SHEET 21



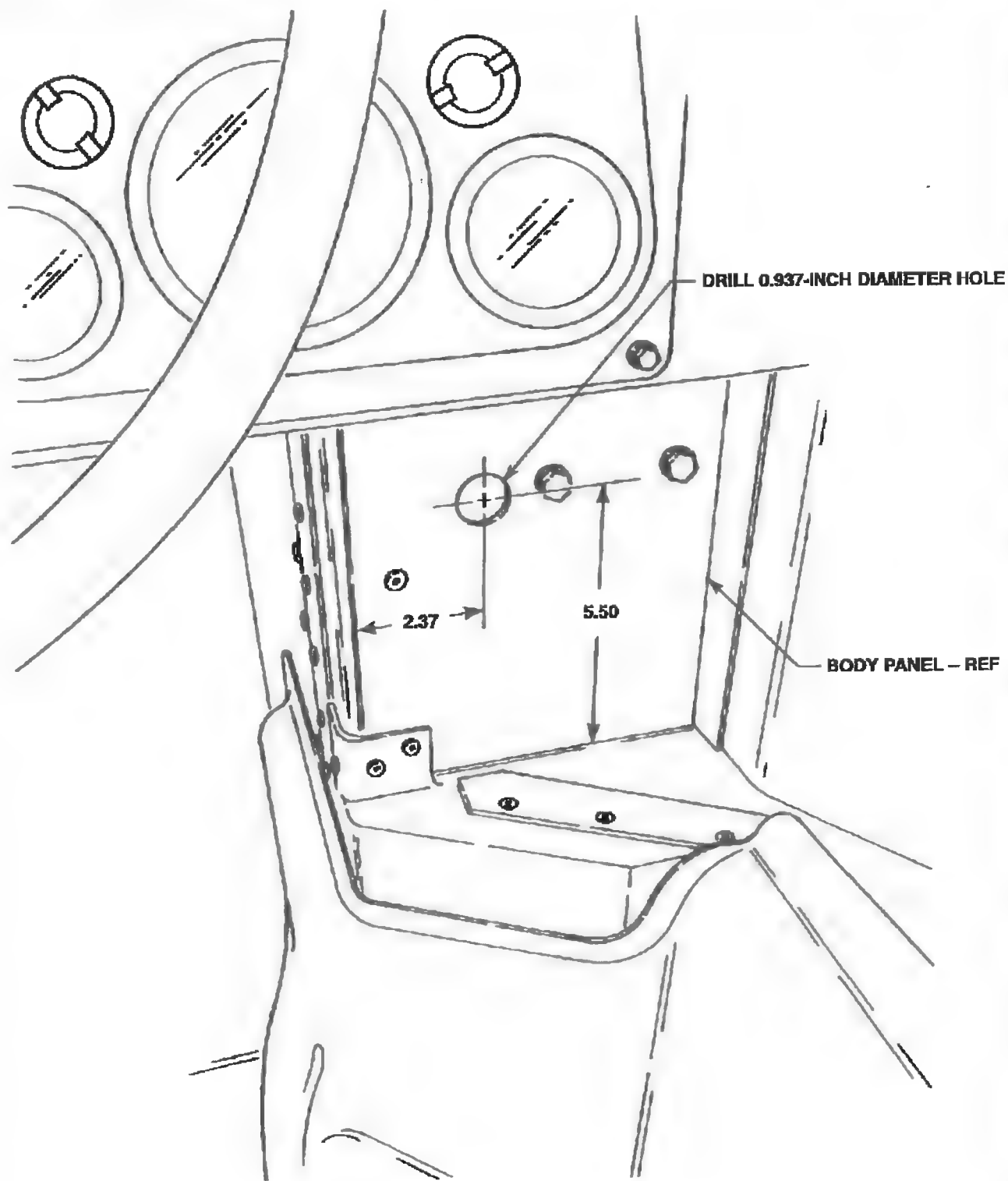

**FIGURE 14**

<b>INSTALLATION INSTRUCTIONS, 10,500 LB HYDRAULIC WINCH ACCESSORY KIT 57K3541</b>	<b>SIZE</b> A	<b>CAGE CODE</b> 19207	<b>12469068</b>	
	(AMG U1805)	02-10-09	<b>REVISION LEVEL</b> A	<b>SHEET 22</b>

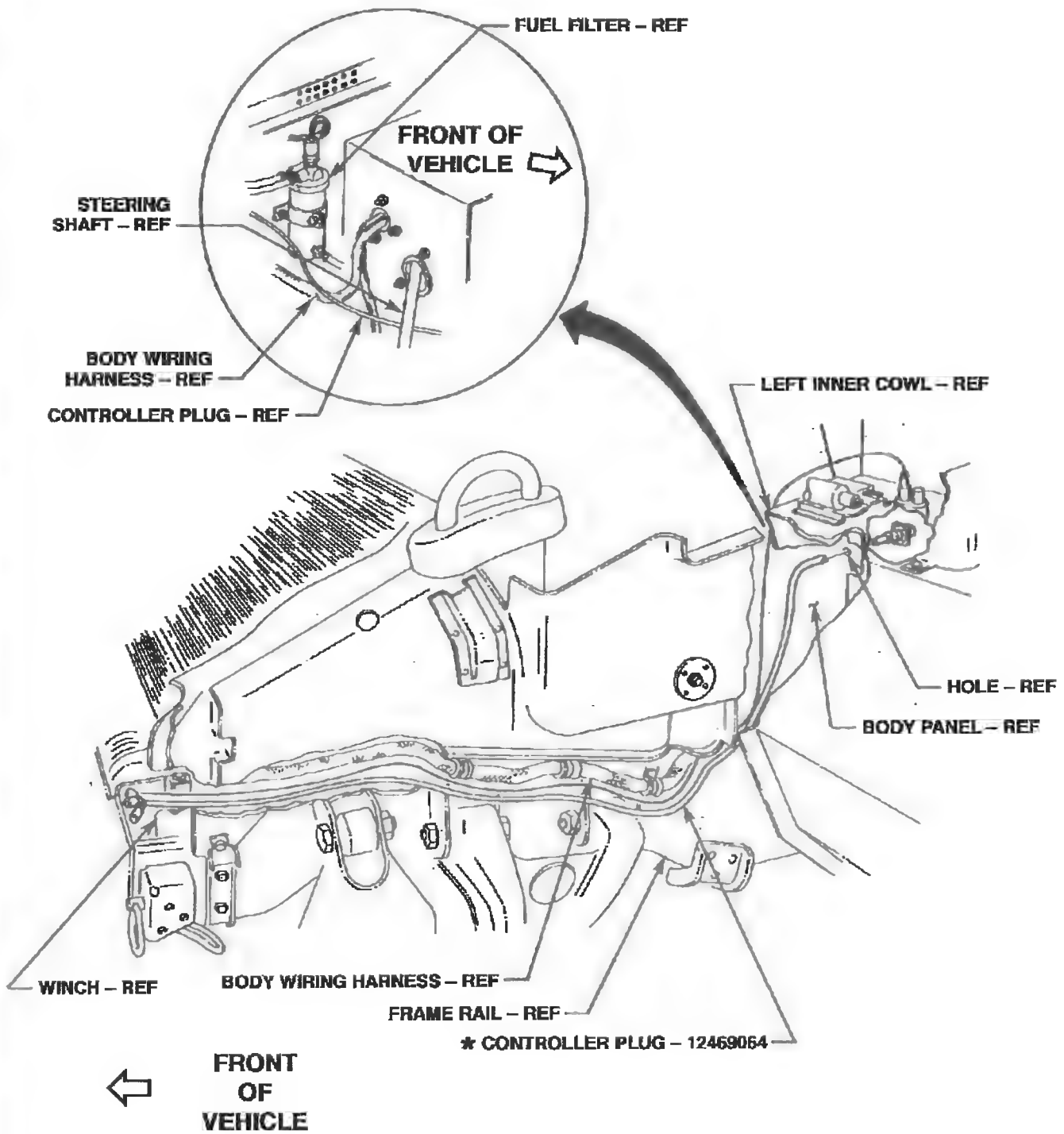

**FIGURE 15**

<b>INSTALLATION INSTRUCTIONS, 10,500 LB HYDRAULIC WINCH ACCESSORY KIT 57K3541</b>	SIZE <b>A</b>	CAGE CODE <b>19207</b>	<b>12469068</b>	
	(AMG U1805)	02-10-09	REVISION LEVEL <b>A</b>	SHEET <b>23</b>

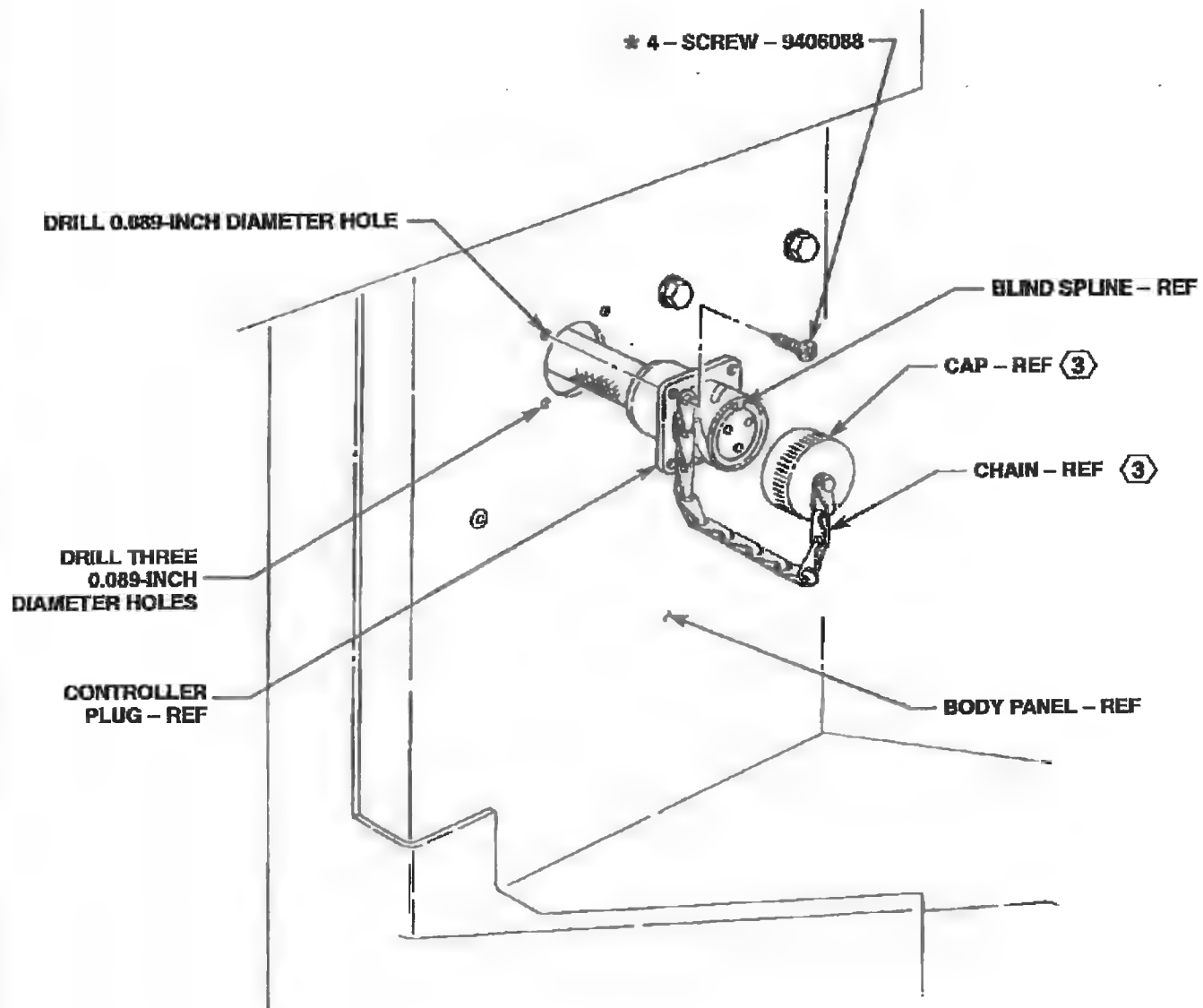

**FIGURE 16**

<b>INSTALLATION INSTRUCTIONS, 10,500 LB HYDRAULIC WINCH ACCESSORY KIT 57K3541</b>	<b>SIZE</b> A	<b>CAGE CODE</b> 19207	<b>12469068</b>	
	(AMG U1805)	02-10-09		

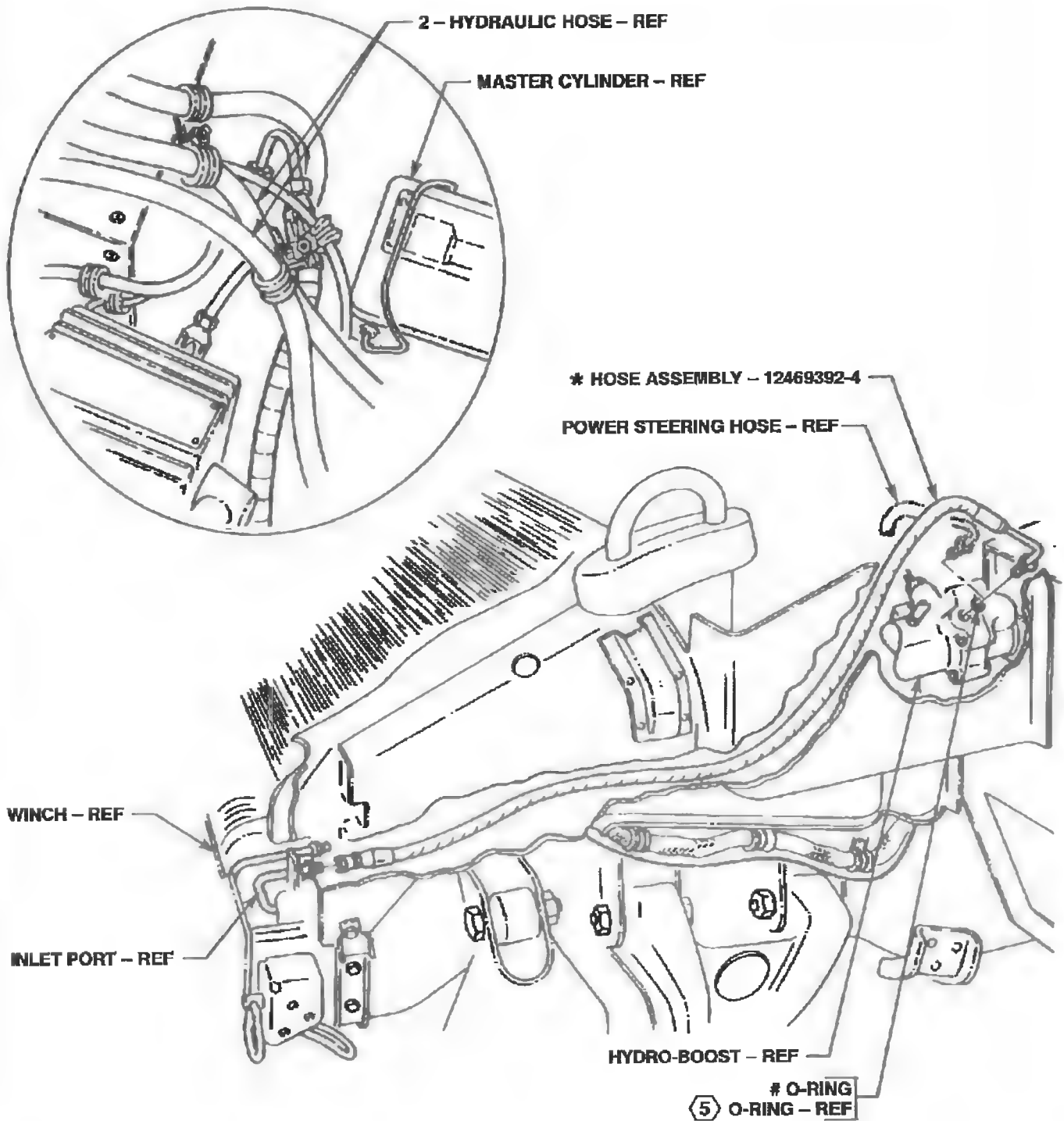

FIGURE 17

INSTALLATION INSTRUCTIONS,  
10,500 LB HYDRAULIC WINCH  
ACCESSORY KIT 57K3541

SIZE  
A

CAGE CODE  
19207

12469068

(AMG U1805)

02-10-09

REVISION LEVEL A

SHEET 25

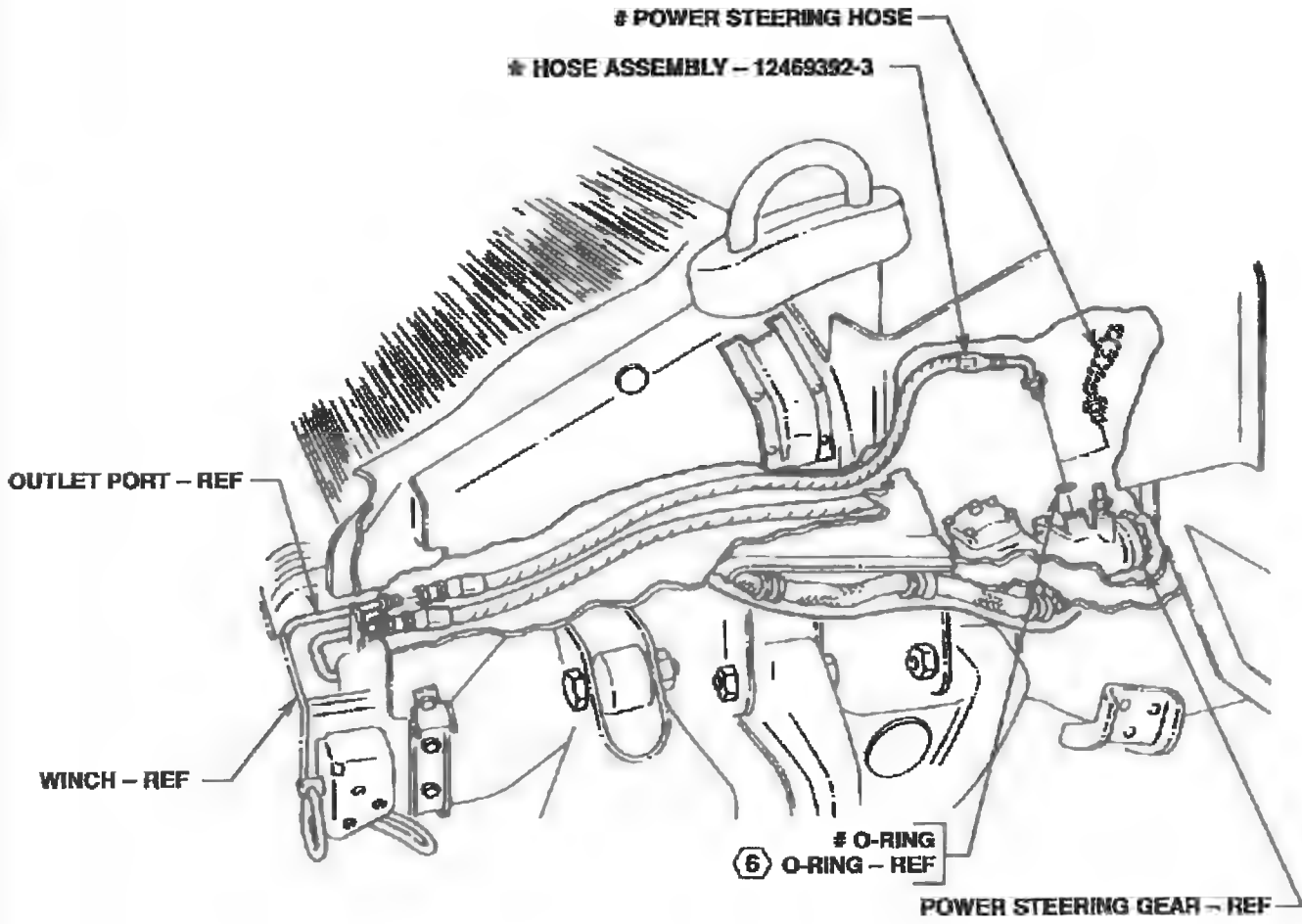
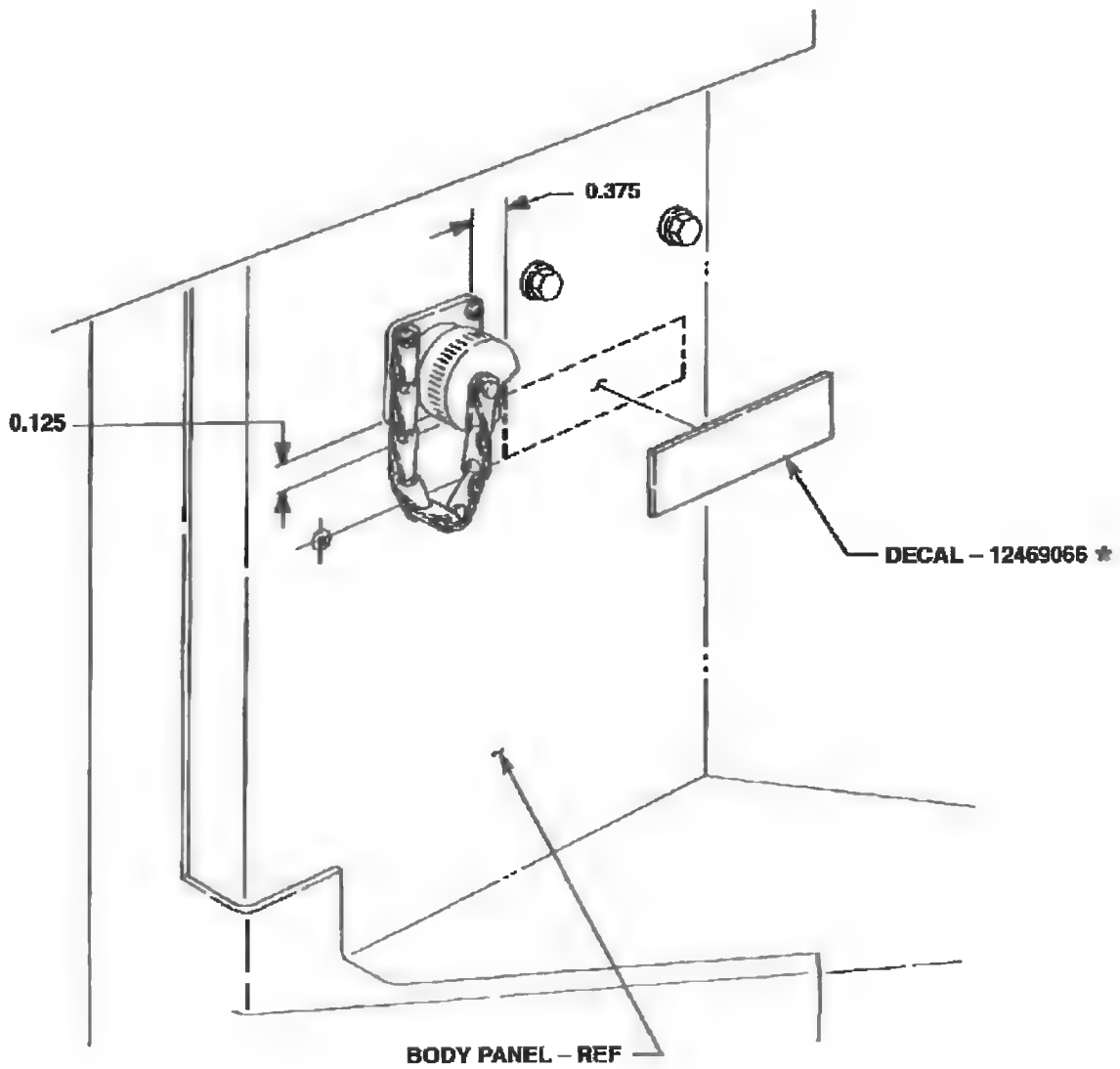

FIGURE 18

<b>INSTALLATION INSTRUCTIONS, 10,500 LB HYDRAULIC WINCH ACCESSORY KIT 57K3541</b>	SIZE <b>A</b>	CAGE CODE <b>19207</b>	<b>12469068</b>	
	(AMG U1805)	02-10-09	REVISION LEVEL <b>A</b>	SHEET <b>26</b>



**FIGURE 19**

**INSTALLATION INSTRUCTIONS,  
10,500 LB HYDRAULIC WINCH  
ACCESSORY KIT 57K3541**

SIZE

**A**

CAGE CODE

**19207**

**12469068**

(AMG U1805)

02-10-09

REVISION LEVEL **A**

SHEET **27**

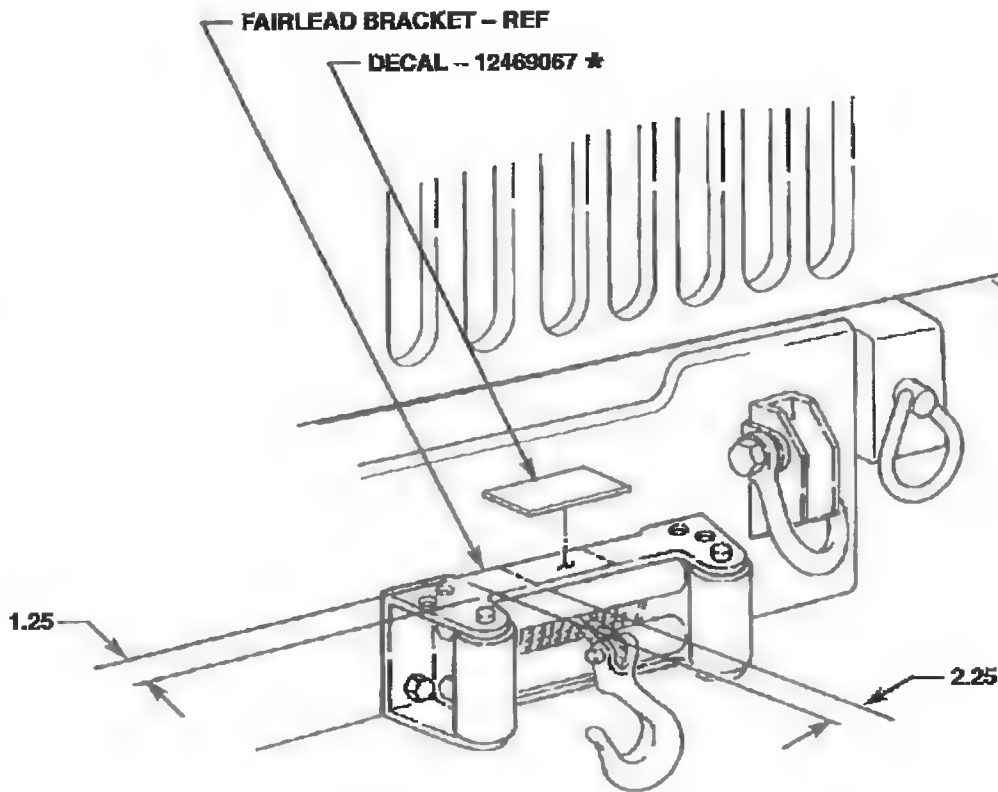

**FIGURE 20**

<b>INSTALLATION INSTRUCTIONS, 10,500 LB HYDRAULIC WINCH ACCESSORY KIT 57K3541</b>	<b>SIZE</b> <b>A</b>	<b>CAGE CODE</b> <b>19207</b>	<b>12469068</b>	
	(AMG U1805)	02-10-09	<b>REVISION LEVEL</b>	<b>A</b>
			<b>SHEET 28</b>	

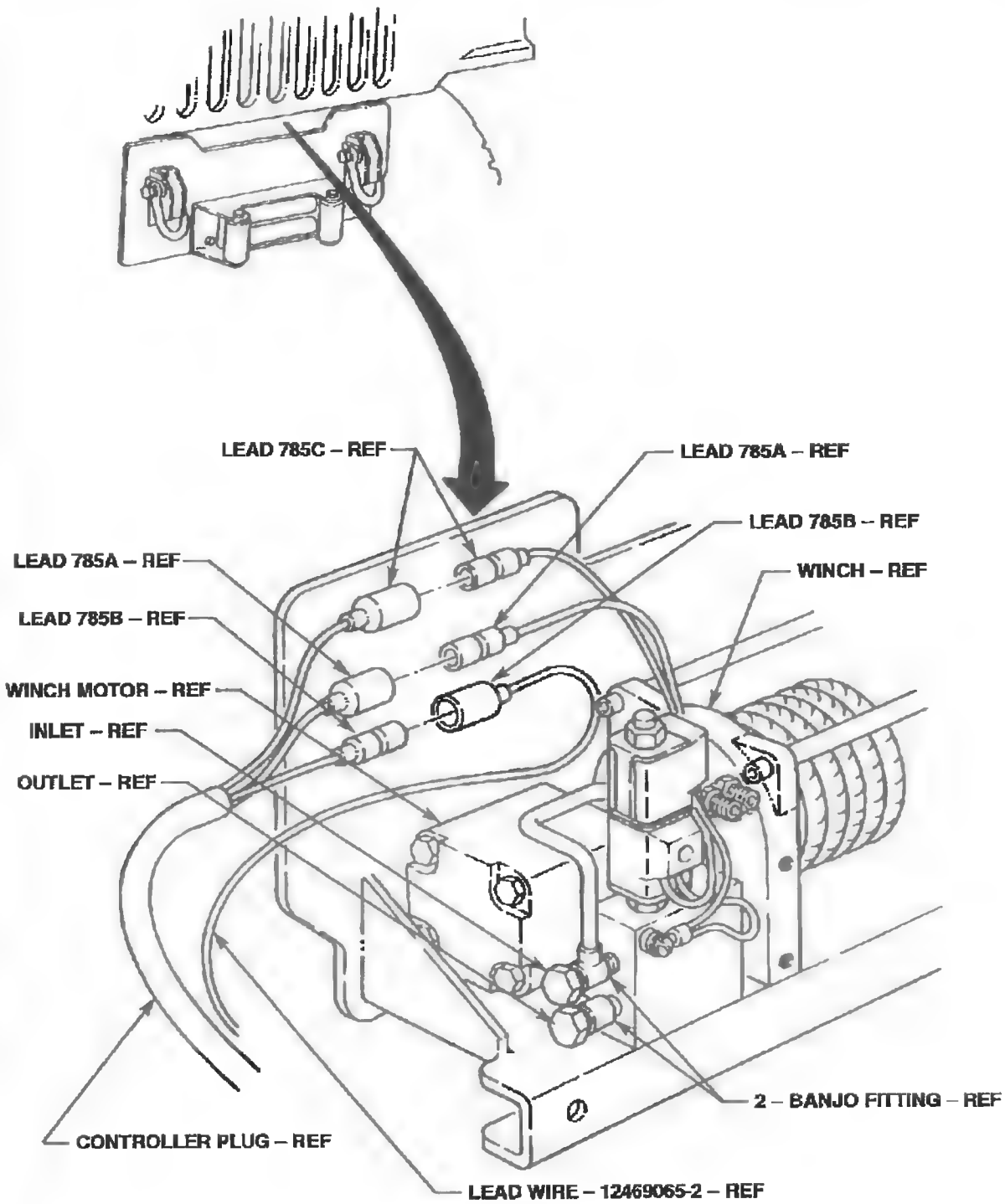

**FIGURE 21**

<b>INSTALLATION INSTRUCTIONS, 10,500 LB HYDRAULIC WINCH ACCESSORY KIT 57K3541</b>	SIZE <b>A</b>	CAGE CODE <b>19207</b>	<b>12469068</b>	
	(AMG U1805)	02-10-09	REVISION LEVEL A	SHEET 29



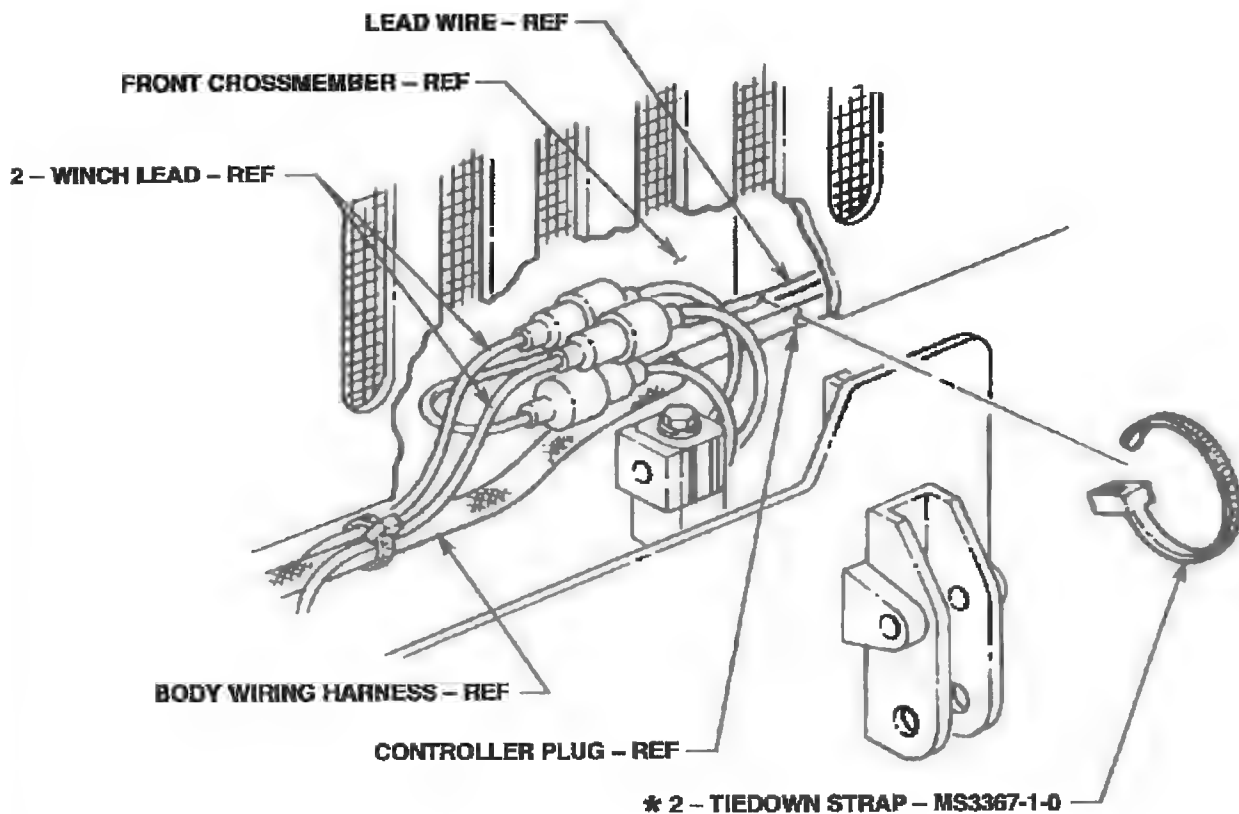

**FIGURE 22**

**INSTALLATION INSTRUCTIONS,  
10,500 LB HYDRAULIC WINCH  
ACCESSORY KIT 57K3541**

SIZE

**A**

(AMG U1805)

CAGE CODE

**19207**

02-10-09

**12469068**

REVISION LEVEL **A**

SHEET **30**

★ 5 - TIEDOWN STRAP - MS3367-7-0 - REF

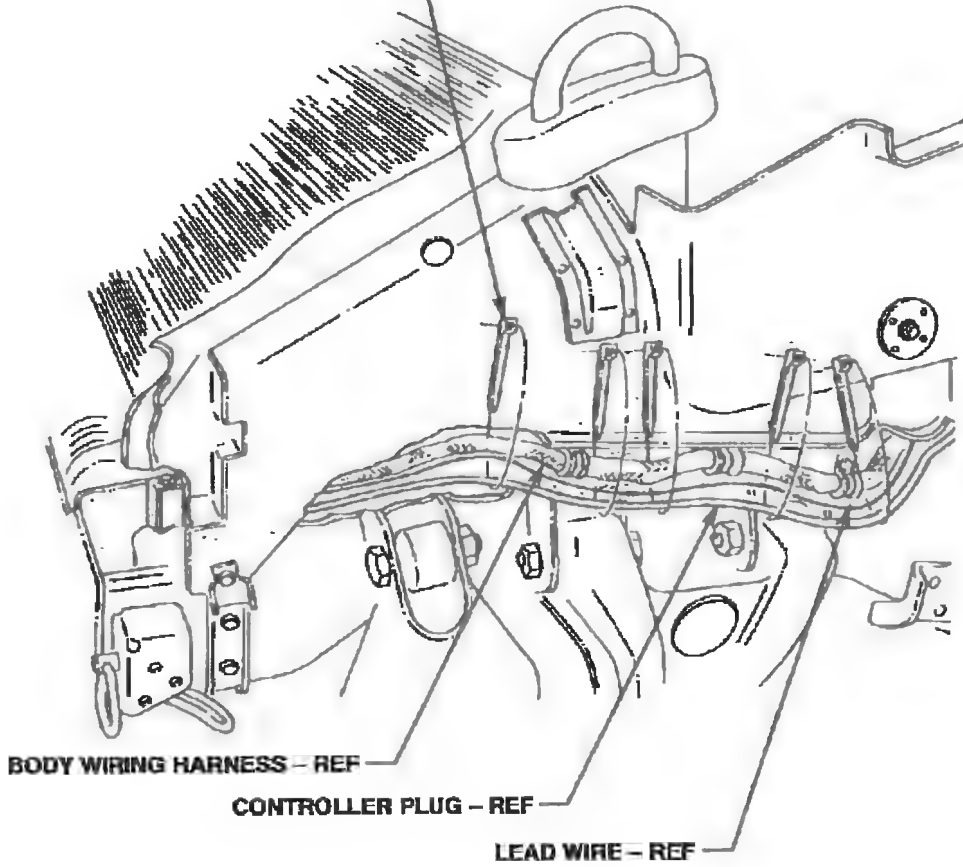

FIGURE 23

INSTALLATION INSTRUCTIONS,  
10,500 LB HYDRAULIC WINCH  
ACCESSORY KIT 57K3541

SIZE  
A

CAGE CODE  
19207

12469068

(AMG U1805)

02-10-09

REVISION LEVEL

A

SHEET 31

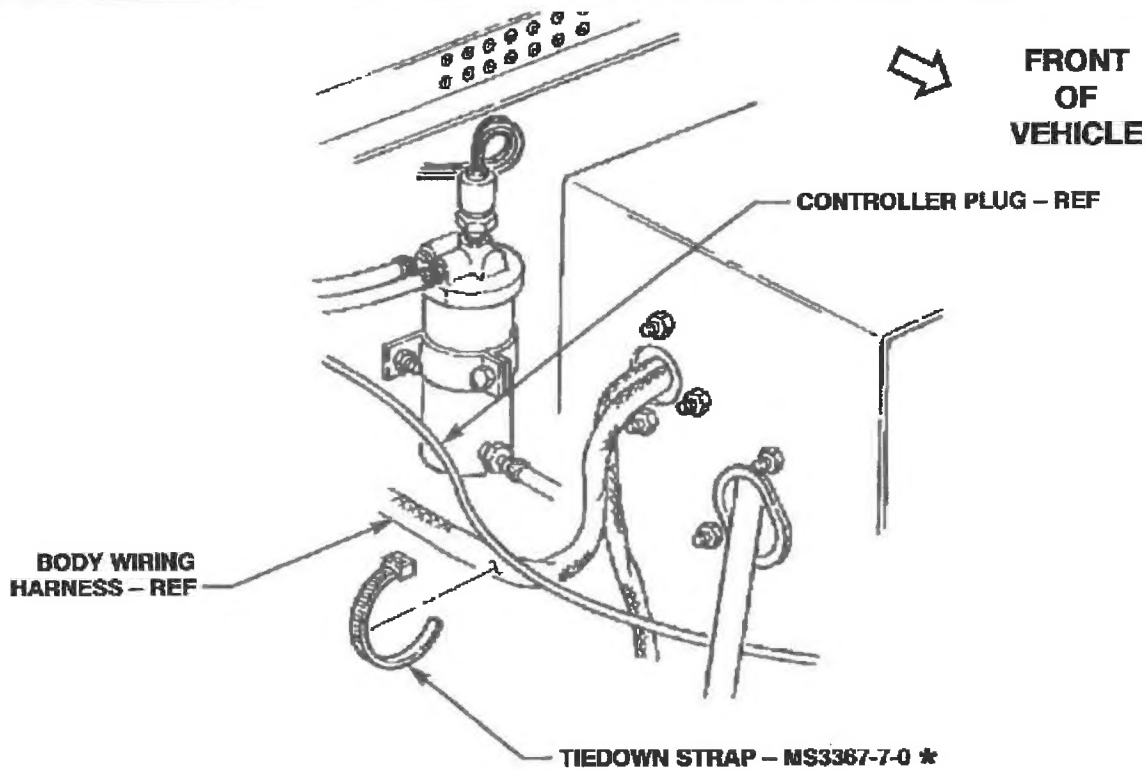
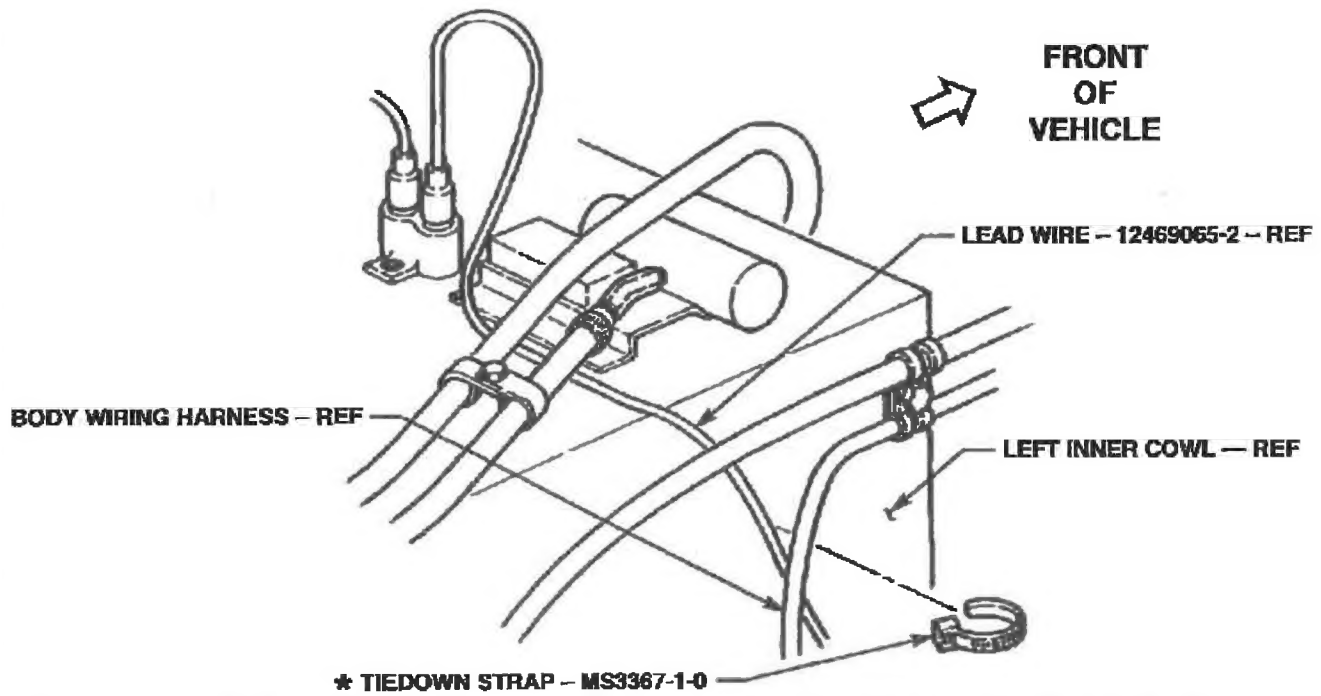

FIGURE 24

INSTALLATION INSTRUCTIONS,  
10,500 LB HYDRAULIC WINCH  
ACCESSORY KIT 57K3541

SIZE

A

CAGE CODE

19207

12469068

(AMG U1805)

02-10-09

REVISION LEVEL A

SHEET 32

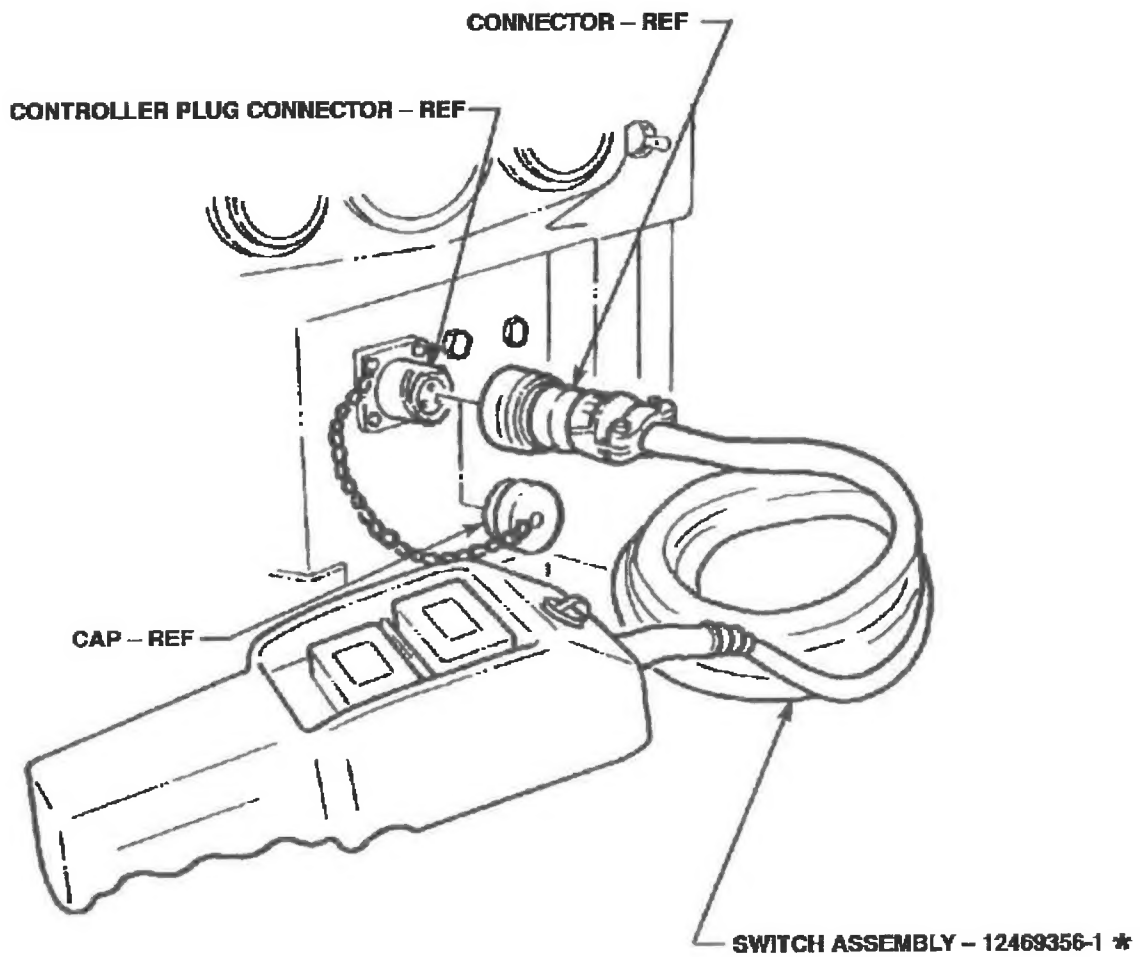
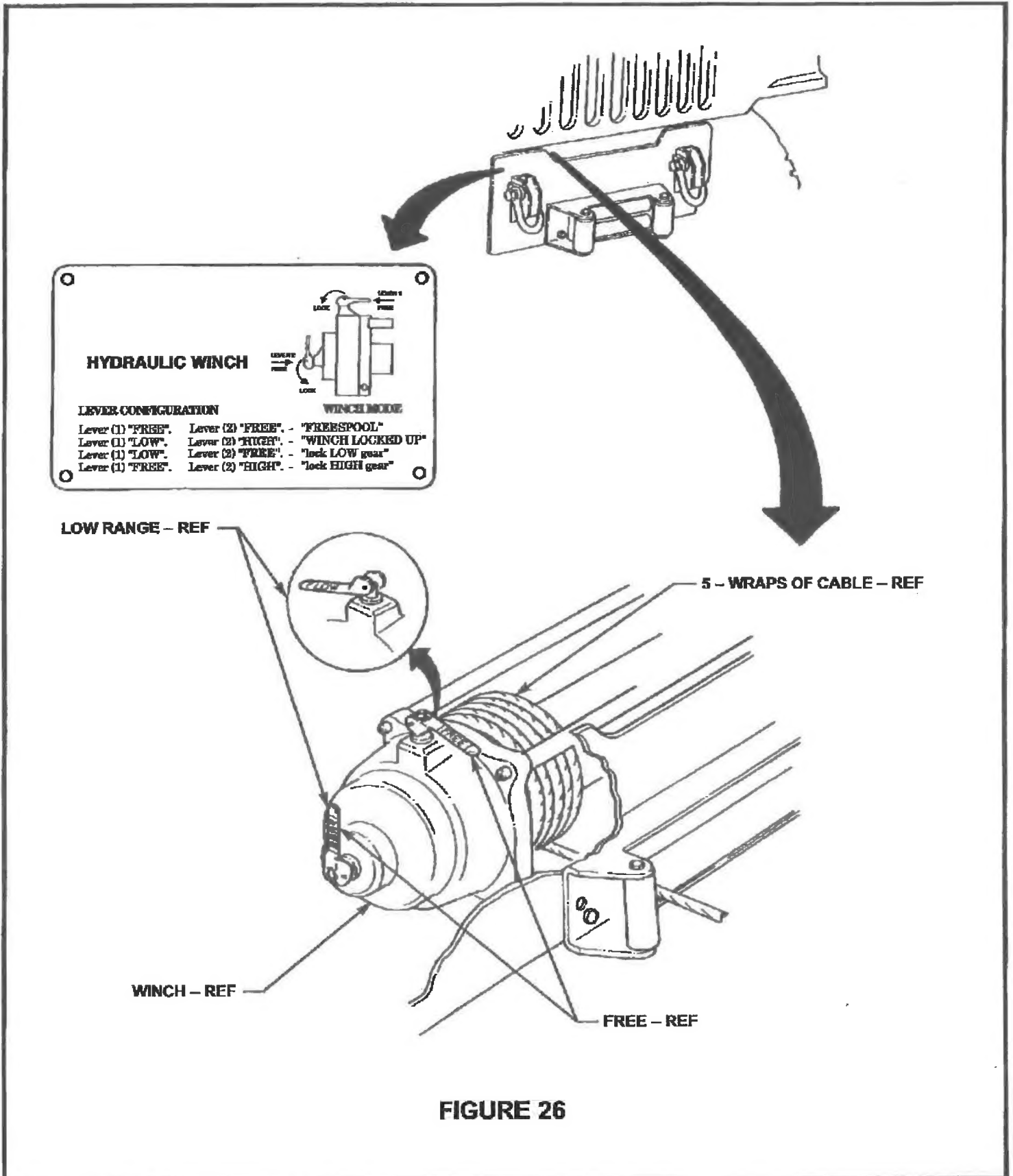

FIGURE 25

<b>INSTALLATION INSTRUCTIONS, 10,500 LB HYDRAULIC WINCH ACCESSORY KIT 57K3541</b>	<b>SIZE</b> A	<b>CAGE CODE</b> 19207	<b>12469068</b>	
	(AMG U1805)	02-10-09	REVISION LEVEL	A SHEET 33



**FIGURE 26**

<b>INSTALLATION INSTRUCTIONS, 10,500 LB HYDRAULIC WINCH ACCESSORY KIT 57K3541</b>	<b>SIZE</b> <b>A</b>	<b>CAGE CODE</b> <b>19207</b>	<b>12469068</b>	
	(AMG U1805)	02-10-09	<b>REVISION LEVEL</b> A	<b>SHEET 34</b>

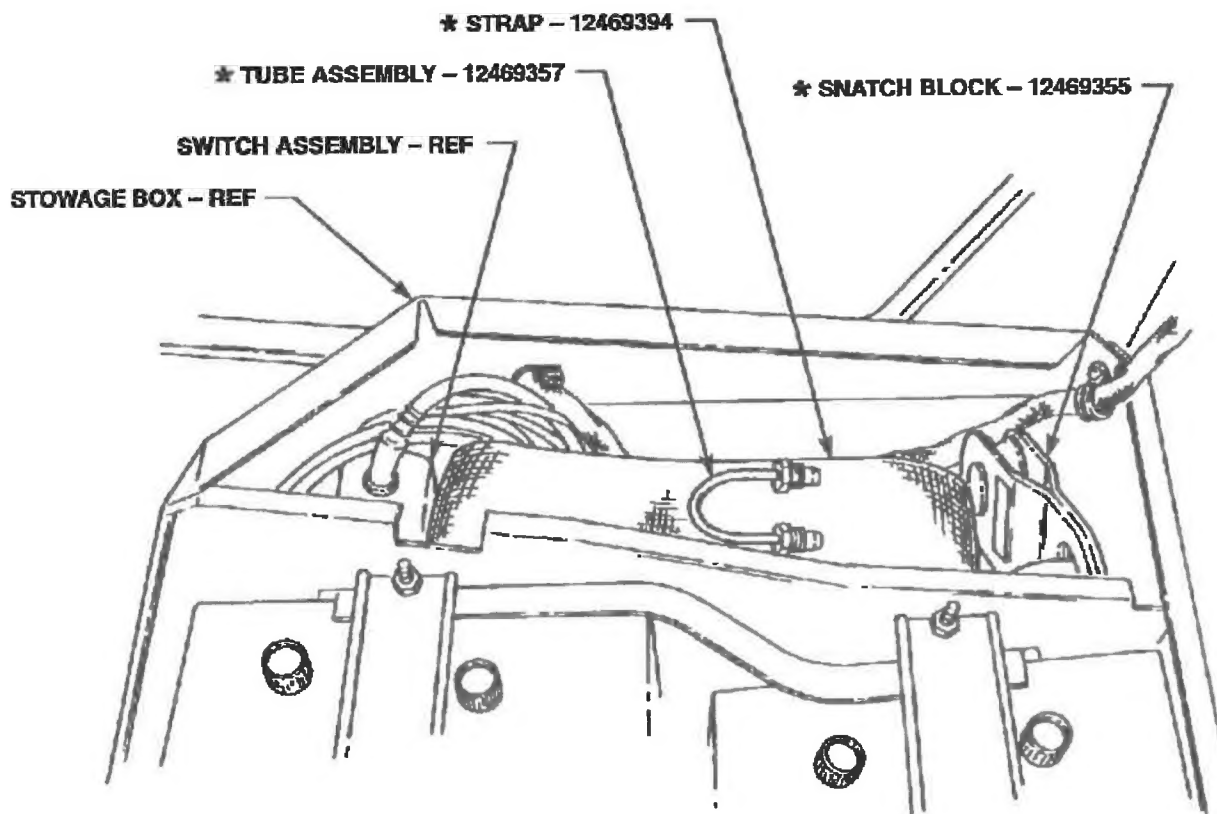

FIGURE 27

INSTALLATION INSTRUCTIONS,  
10,500 LB HYDRAULIC WINCH  
ACCESSORY KIT 57K3541

SIZE

A

CAGE CODE

19207

12469068

(AMG U1805)

02-10-09

REVISION LEVEL A

SHEET 35