

INSTALLATION INSTRUCTIONS FOR M998/M1038 VEHICLES LIGHTWEIGHT WEAPONS STATION

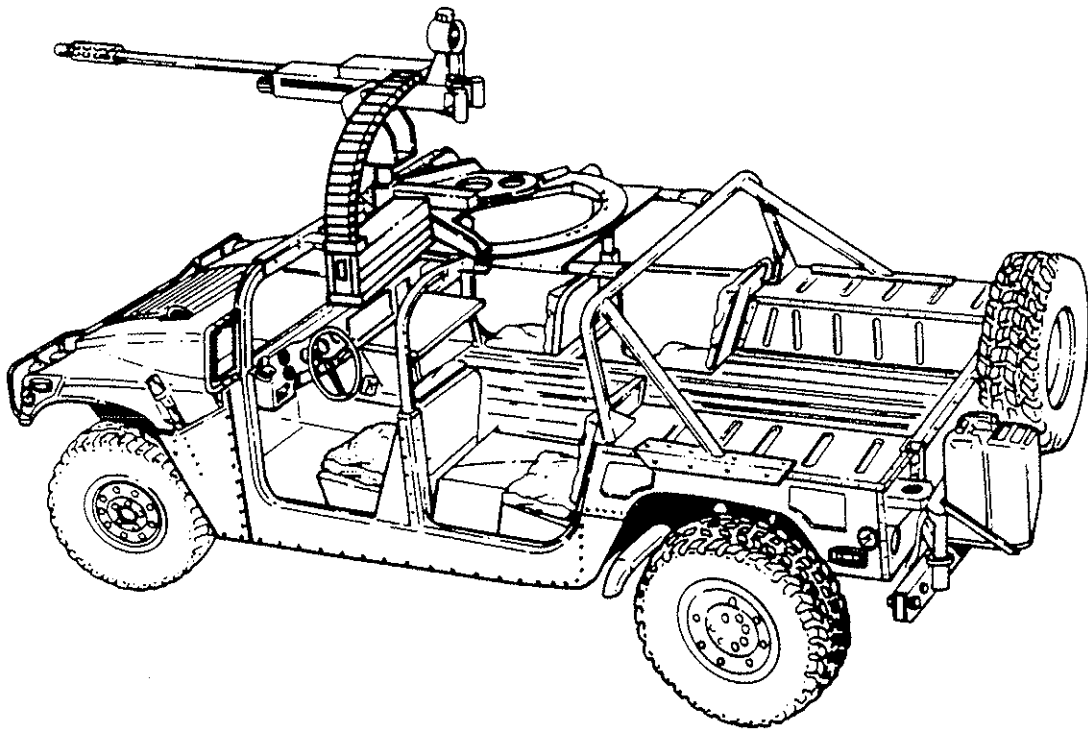

AM General Corporation

A subsidiary of LTV Aerospace and Defense Company

CAGE: 9C234

FEBRUARY 1991

M998/M1038 VEHICLES INSTALLATION INSTRUCTIONS LIGHTWEIGHT WEAPONS STATION

INTRODUCTION

- A. **PURPOSE.** The purpose of these instructions is to provide a procedure for installation lightweight weapons station on M998/M1038 vehicles.
- B. These instructions are divided into three sections.
 - 1. Section I contains step-by-step written procedures keyed to figures and references.
 - 2. Section II contains figures developed from installation layout drawings.
 - 3. Section III contains extracts from applicable technical manuals.
- C. Callouts are identified as follows:
 - * New parts.
 - # Parts to be removed and discarded.
- D. **MATERIAL.** All material removed and not reused during installation will be returned to stock.
- E. These instructions are current as of 15 Feb 91.

Section I. INSTALLATION PROCEDURES

- 1-1. **VEHICLE PREPARATION.**
 - A. Remove battery ground cable. (See section III, page 2.)
 - B. Remove two-man crew area soft top enclosure, if installed. (See section III, pages 3 through 5.)
 - C. Remove troop area soft top enclosure, if installed. (See section III, page 6.)
 - D. Remove four-man crew area soft top enclosure, if installed. (See section III, pages 7 and 8.)
 - E. Remove four-man cargo area soft top enclosure, if installed. (See section III, pages 9 and 10.)
 - F. Remove passenger seat backs, if installed. (See section III, page 11.)
 - G. Remove fixed rear doors, if installed. (See section III, page 12.)
 - H. Remove soft top door strikers, if installed. (See section III, page 13.)
 - I. Remove three-point seatbelt "D" rings from "B" pillar, if installed. (See section III, pages 14 through 17).

- J. Remove rear seatbelt from seatbelt bracket, if installed. (See section III, pages 14 through 17).
- K. Remove "B" pillar, if installed. (See section III, page 18.)
- L. Remove rear seatbelt brackets, if installed. (See section III, pages 20 and 21).
- M. Remove "C" pillar, if installed. (See section III, page 19.)
- N. Remove six screws and washers, and three nuts securing left and right rear windshield mounting brackets and shims (if installed) to windshield frame as shown in section II, figure 1.
- O. Remove two screws, washers, and nuts securing door stop straps to left and right side "A," and "B" pillars, if installed, as shown in section II, figure 1.
- P. Remove two screws, washers, and nuts from left and right wheelhouse as shown in section II, figure 2.
- Q. Remove four screws, washers, and nuts securing forward two footman loops to left and right wheelhouse as shown in section II, figure 2.
- R. Remove two rivets from right wheelhouse as shown in section II, figure 2. (See section III, page 22.)

1-2. REAR SUPPORT MOUNT INSTALLATION.

- A. Position 5936215 left rear support mount assembly on left wheelhouse and align outer hole in support mount bracket with existing outer hole in top of wheelhouse as shown in section II, figure 3.
- B. Position two 5936234 shims between side of wheelhouse and "L" bracket and one 5936235 shim between top of wheelhouse and "L" bracket as shown in section II, figure 3.
- C. Using "L" bracket as a template, locate and mark nine hole positions on wheelhouse as shown in section II, figure 3.
- D. Using support mount bracket as a template, locate and mark inner hole position on top of wheelhouse as shown in section II, figure 3.
- E. Drill ten 0.406-inch diameter holes in wheelhouse in positions marked in steps "C" and "D" above.
- F. Repeat steps "A" through "E" above on right wheelhouse using 5936216 right rear support mount assembly.
- G. Install left and right rear support mount assemblies in 5936262 rear weapons station support assembly and attach with four MS90728-71 screws, eight G-2436163 washers, and four MS51943-35 nuts as shown in section II, figure 4. Do not tighten nuts.
- H. Position left and right rear support mount assemblies and rear weapons station support assembly on left and right wheelhouse and attach with twenty MS90728-60 screws, two 5936235 shims, four 5936234 shims, forty G-2436163 washers, and twenty MS51943-35 nuts as shown in section II, figure 5.

1-3. WINDSHIELD REAR MOUNT BRACKET INSTALLATION.

- A. Position 5936448 rear windshield mount bracket to left windshield frame and secure with three MS90728-35 screws and three G-2436162 washers as shown in section II, figure 6.
- B. Secure windshield mount bracket to left "A" pillar with three MS90728-36 screws, six G-2436162 washers, and three MS51943-33 nuts as shown in section II, figure 6.

- C. Position 5936448 rear windshield mount bracket to right windshield frame and secure with three MS90728-35 screws and three G-2436162 washers as shown in section II, figure 6.
- D. Secure windshield mount bracket to right "A" pillar with three MS90728-36 screws, six G-2436162 washers, and three MS51943-33 nuts as shown in section II, figure 6.

1-4. FRONT WEAPONS STATION MOUNTING BRACKET INSTALLATION.

- A. Position 5937222 template on left upper windshield frame so that slot in template aligns with existing slot in windshield frame as shown in section II, figure 7.
- B. Using template, locate and mark position of eight mount holes and slot to be cut out in windshield frame as shown in section II, figure 7.
- C. Drill eight 0.344-inch diameter holes in windshield frame as marked in step "B" above.
- D. Cut out slot as marked on windshield frame in step "B" above.
- E. Position two 12338837 turret support reinforcements on upper windshield frame and secure with eight MS90728-34 screws and G-2436162 washers as shown in section II, figure 7.
- F. Using turret support reinforcements as a template, locate and mark four rivet positions on bottom of upper windshield frame as shown in section II, figure 7.
- G. Remove eight screws and washers and two turret support reinforcements installed in step "E" above.
- H. Drill four 0.192-inch diameter holes in bottom of upper windshield frame as shown in section II, figure 7.
- I. Position two turret support reinforcements on bottom of upper windshield frame and secure with four M7885/2-6-4 rivets as shown in section II, figure 7.
- J. Position 5936307 front weapons station mounting bracket on upper windshield frame and align with holes drilled in step "C" above as shown in figure 8.
- K. Using front weapons station mounting bracket as a template, locate, mark, and drill three 0.437-inch diameter holes in top of upper windshield frame as shown in section II, figure 8.
- L. Install three 12339998-12 plusnuts in holes drilled in step "K" above as shown in section II, figure 8.
- M. Position 5936319 shim and front weapons station mounting bracket on upper windshield frame and secure with three MS90728-36 screws, MS35338-45 lockwashers, and G-2436162 washers as shown in section II, figure 8.
- N. Install eight screws and washers removed in step "G" above and eight MS35338-45 lockwashers as shown in section II, figure 8.
- O. Repeat steps "A" through "N" for right front windshield mount installation.
- P. Position four 12339571 rubber bushings and four 12339561 snubber plates on front and rear weapons station mount as shown in figures 9 and 10.

1-5. WEAPONS STATION INSTALLATION.

- A. Position two 5936210 left-hand support assemblies and two 5936295 right-hand support assemblies into 5937386 weapons station and attach with twelve MS90728-70 screws, twenty-four G-2436163 washers, and twelve MS51943-35 nuts as shown in section II, figure 11. Do not tighten screws.

WARNING

Weapons station is heavy. Use a lifting device during installation. Failure to do so may result in injury to personnel or damage to equipment.

- B. Using appropriate lifting device, position 5937386 weapons station over vehicle. Lower weapons station so that front and rear support assemblies rest on snubber plates and upper bushings as shown in section II, figures 12 through 14.
- C. Secure two front weapons station mount support assemblies to front weapons station mount with two snubber plates and rubber bushings positioned on front weapons station mounts in para. 1-4, step "P" and two MS90728-73 screws, four G-2436163 washers, two 12338186-52 spacers, two 12339561 snubber plates, two 12339571 rubber bushings, and two MS51943-35 nuts as shown in section II, figures 12 through 14.
- D. Secure two rear weapons station mount support assemblies to rear weapons station mount with two snubber plates and rubber bushings positioned on rear weapons station mounts in para. 1-4, step "P" and two MS90728-73 screws, four G-2436163 washers, two 12338186-52 spacers, two 12339561 snubber plates, two 12339571 rubber bushings, and two MS51943-35 nuts as shown in section II, figures 12 through 14.
- E. Tighten four screws and nuts installed in para. 1-2, step "G."
- F. Tighten twelve screws and nuts installed in para. 1-5, step "A."
- G. Position 5936180 left center support bracket to "B" pillar body and attach with four AN5-41 screws, eight 12339724 washers, and four MS51943-34 nuts as shown in section II, figure 12. Do not tighten nuts.
- H. Position sufficient number of 5936452 shims between left center support bracket and weapons station to fill gap.
- I. Secure center support bracket to weapons station with shim(s), 5936177 support bracket, two G-2436163 washers, and two MS90728-66 screws as shown in section II, figure 12.
- J. Position 5936181 right center support bracket to "B" pillar and attach with four AN5-41 screws, eight 12339724 washers, and four MS51943-34 nuts as shown in section II, figure 12. Do not tighten nuts.
- K. Repeat steps "G" and "H" above for right side of weapons station.
- L. Tighten screws and nuts installed in steps "F" and "I" above.
- M. Secure front seatbelt "D" rings to weapons station center support with two 12340259-4 screws, 12340058 washers, 12342381 brackets, 2436164 washers, and 9422300 nuts. (See section III, pages 14 through 17 - Armament Vehicle.)
- N. Secure rear seatbelt retractors and "D" rings to bracket with two 453124 screws, 2436164 washers, 12340259-7 screws, and 12340058 washers. (See section III, pages 14 through 17 - Armament Vehicle.)

Section II
FIGURES

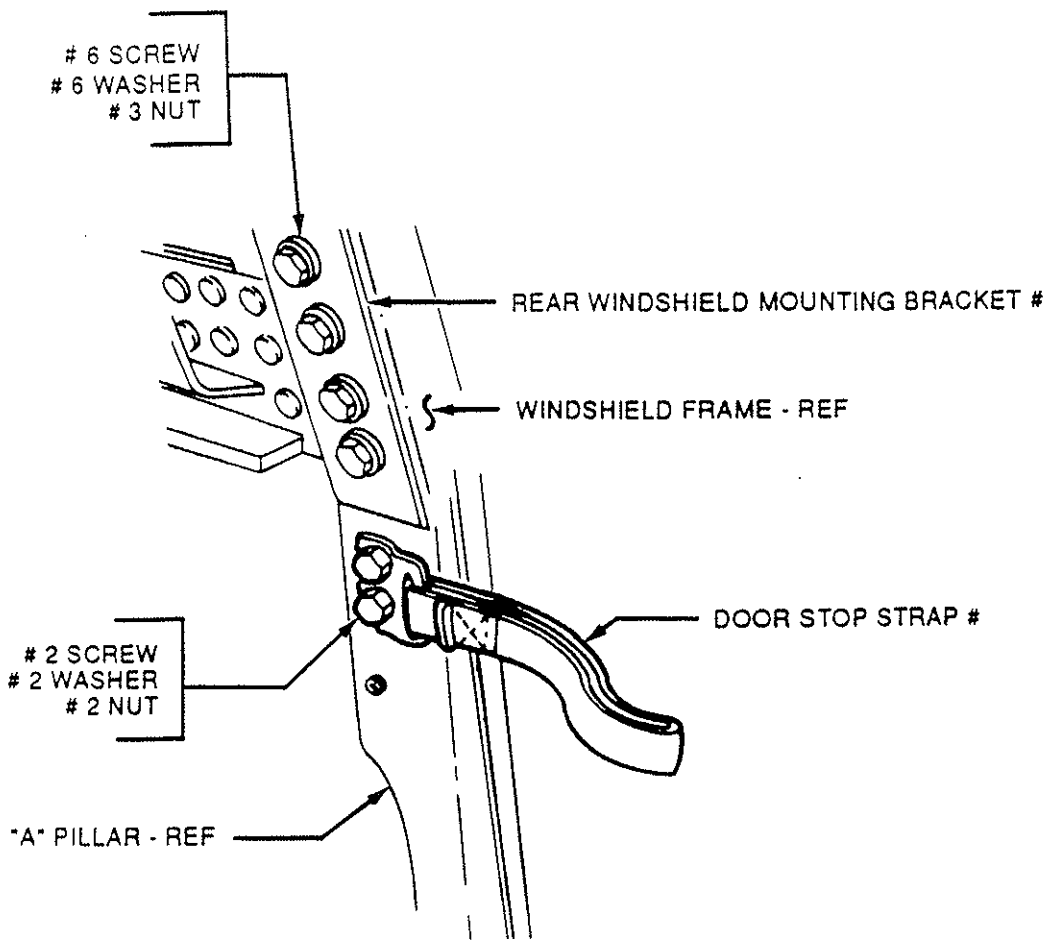

RIGHT SIDE SHOWN,
LEFT SIDE OPPOSITE

Figure 1

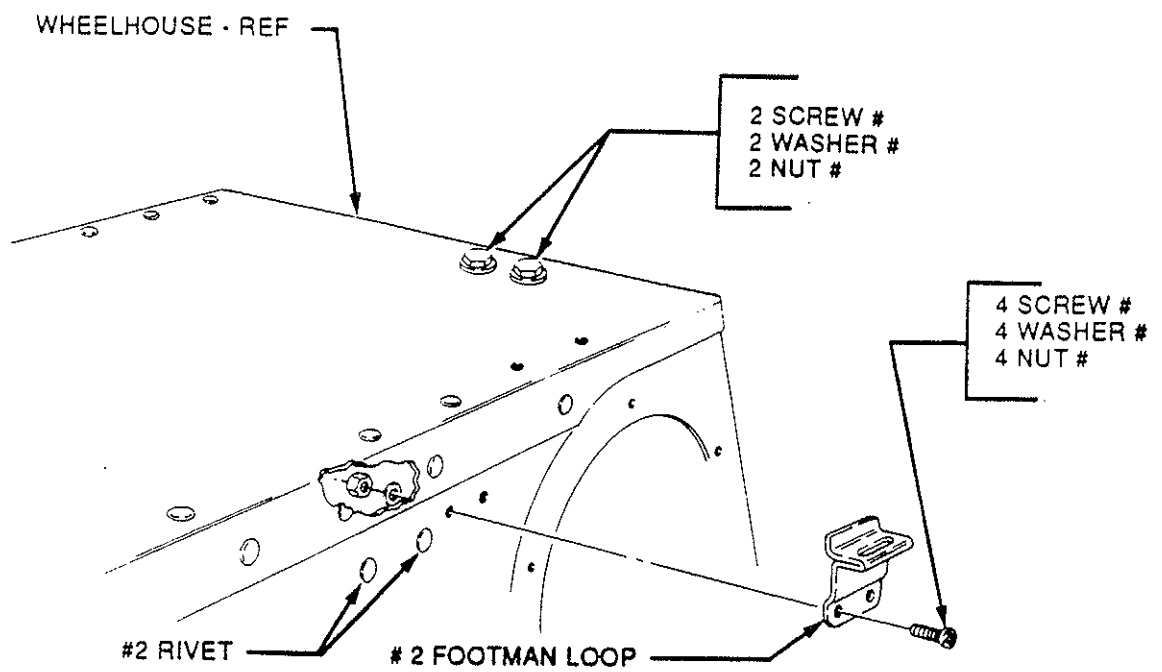

RIGHT SIDE SHOWN,
LEFT SIDE OPPOSITE

Figure 2

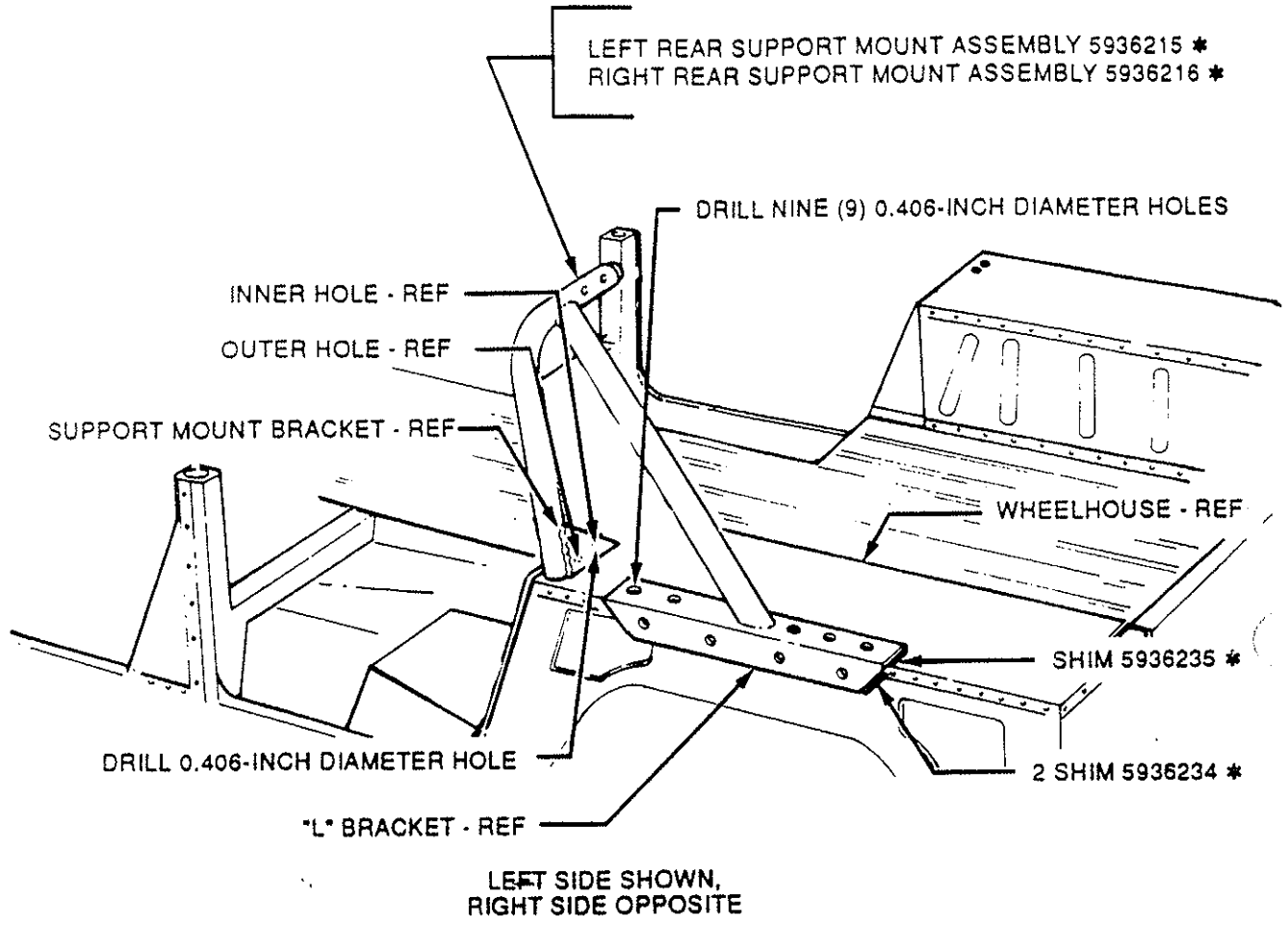

Figure 3

RIGHT REAR SUPPORT MOUNT ASSEMBLY (5936216) - REF

* REAR WEAPONS STATION SUPPORT ASSEMBLY 5936262

* 4 SCREW MS90728-71

* 8 WASHER G-2436163

* 4 NUT MS51943-35

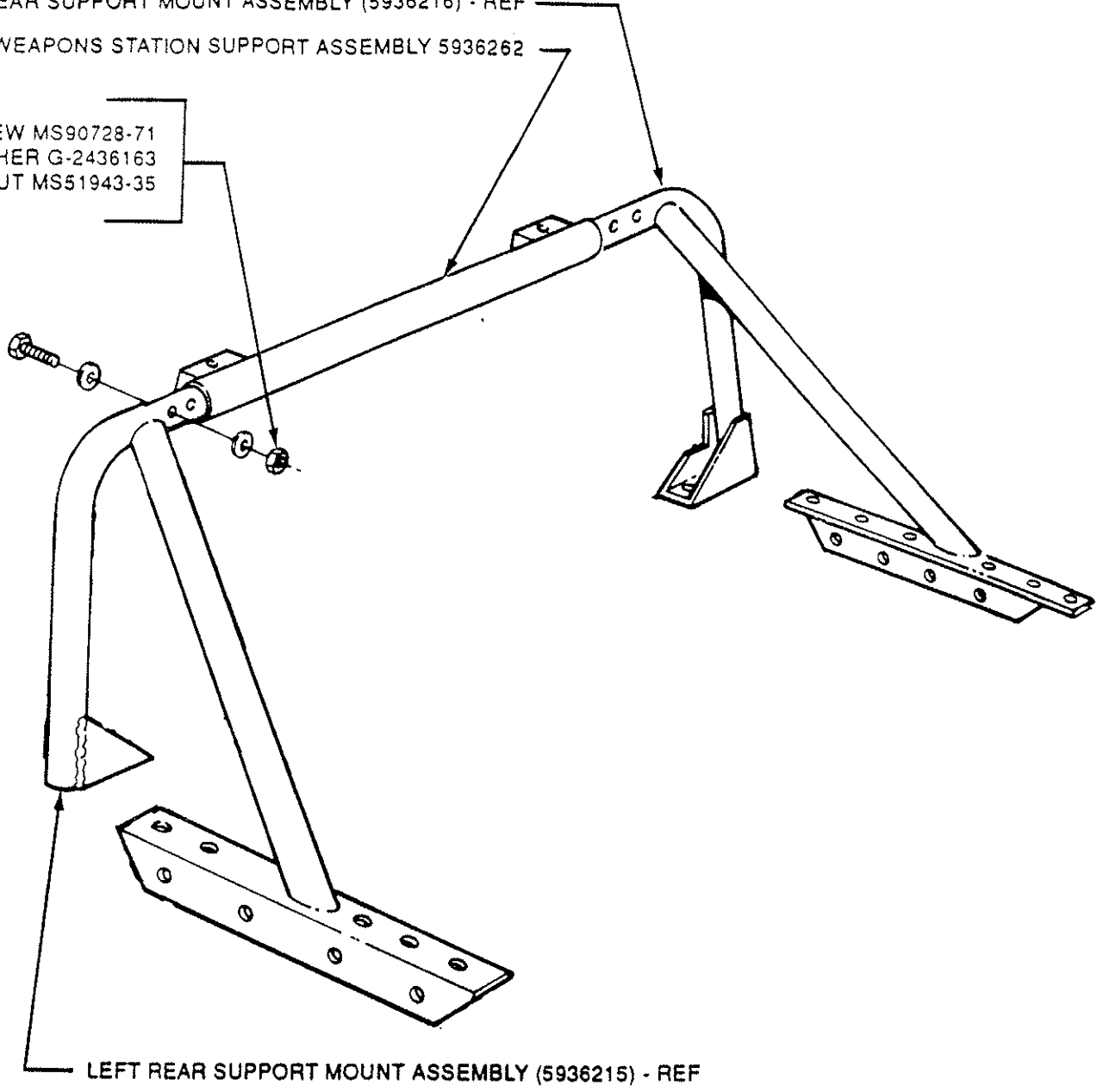

LEFT REAR SUPPORT MOUNT ASSEMBLY (5936215) - REF

Figure 4

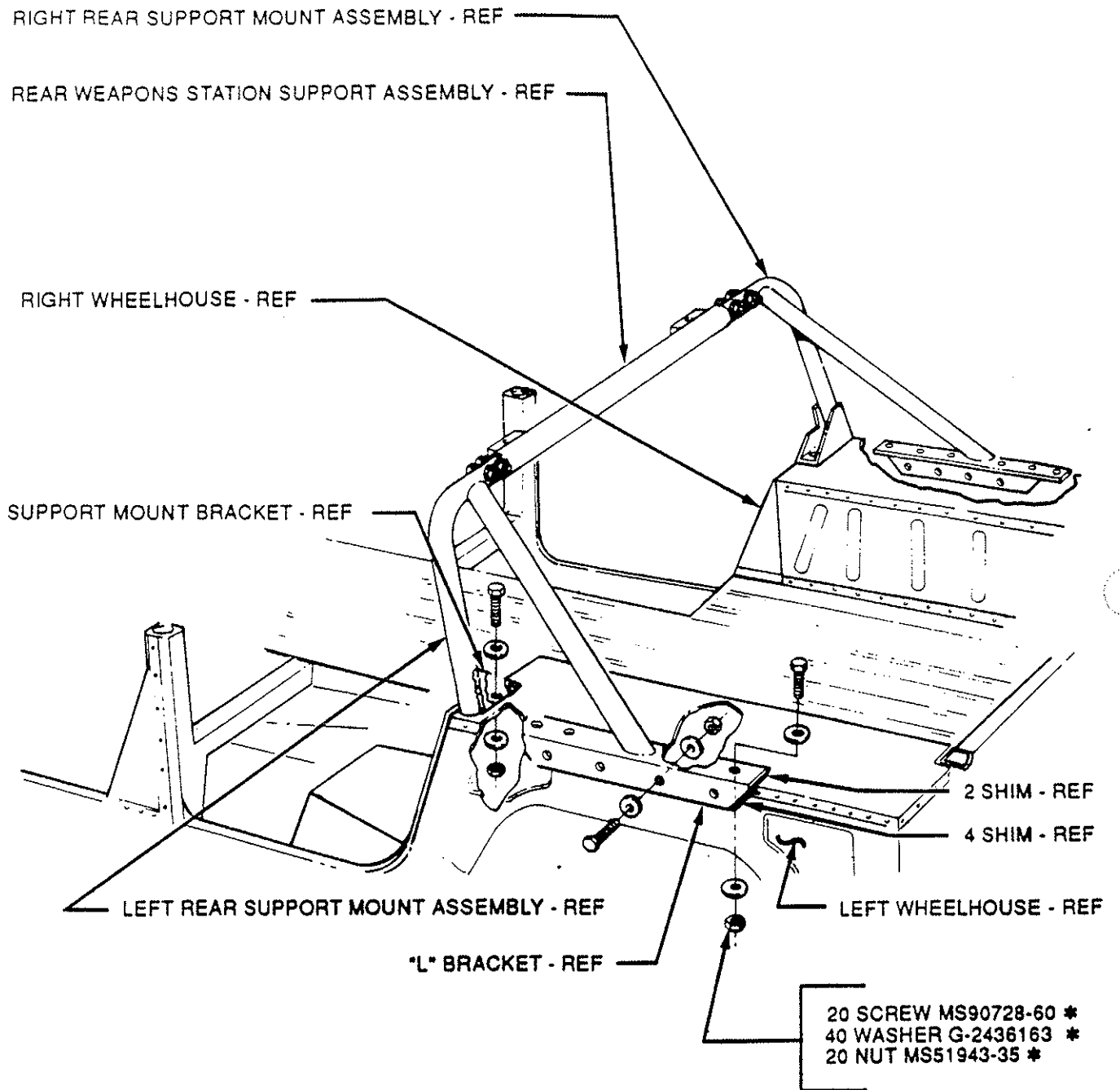
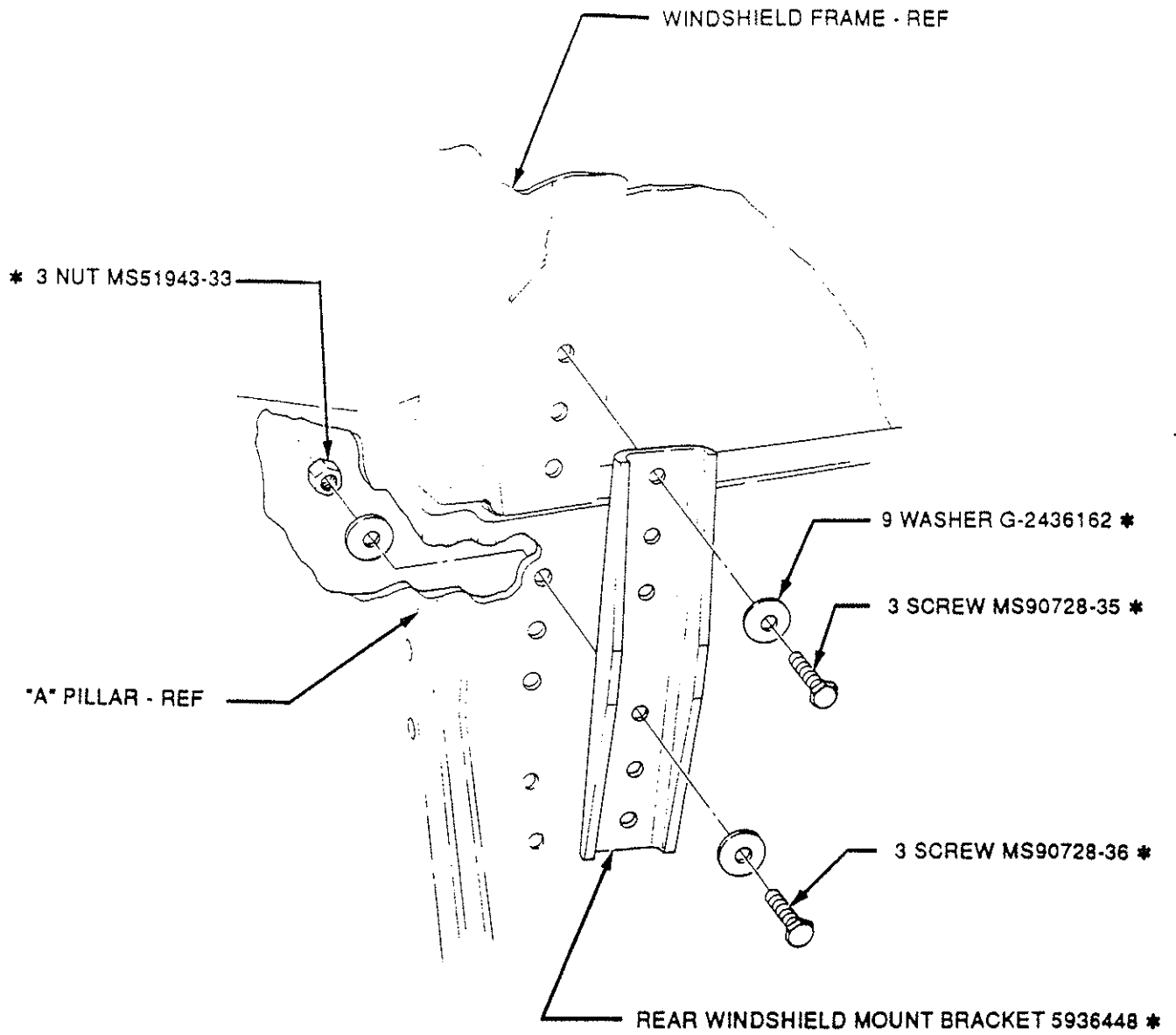

Figure 5



LEFT SIDE SHOWN,
RIGHT SIDE OPPOSITE

Figure 6

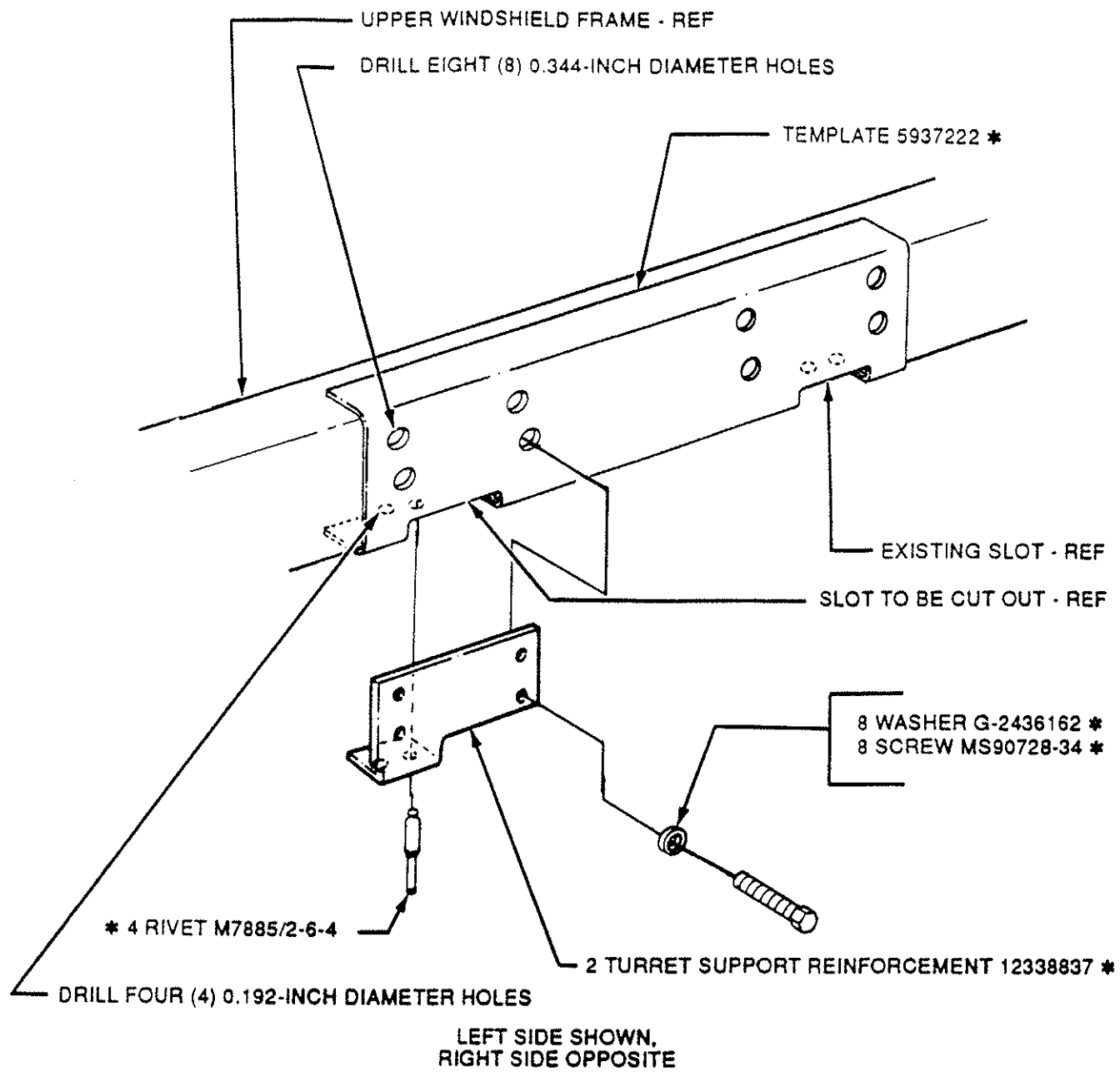
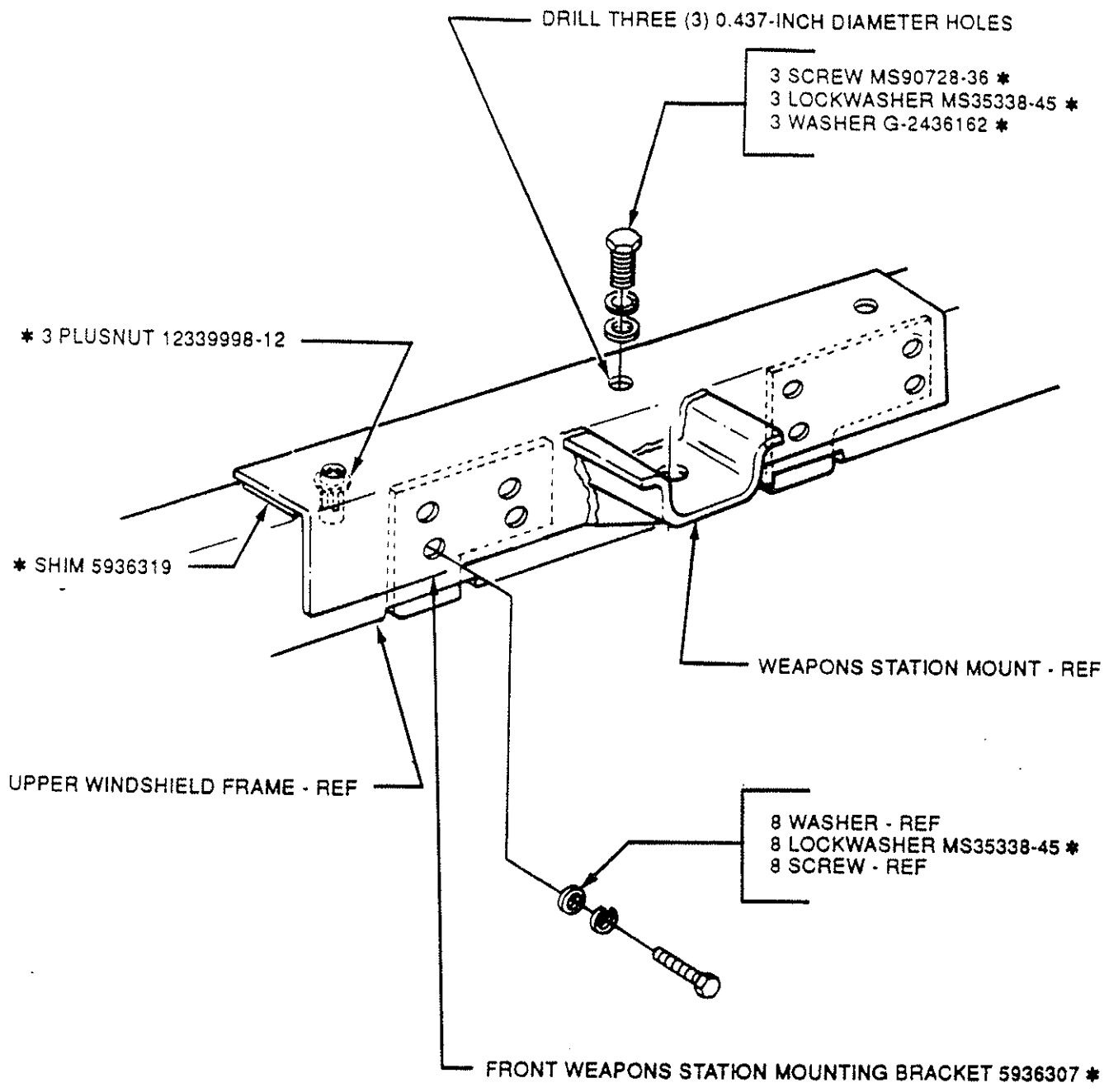
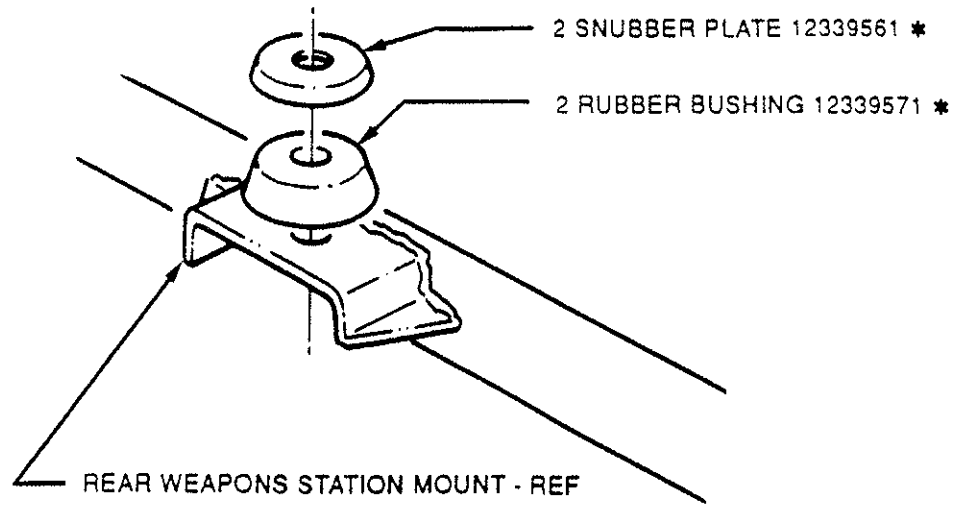

Figure 7



LEFT SIDE SHOWN,
RIGHT SIDE OPPOSITE

Figure 8



RIGHT SIDE SHOWN,
LEFT SIDE OPPOSITE

Figure 9

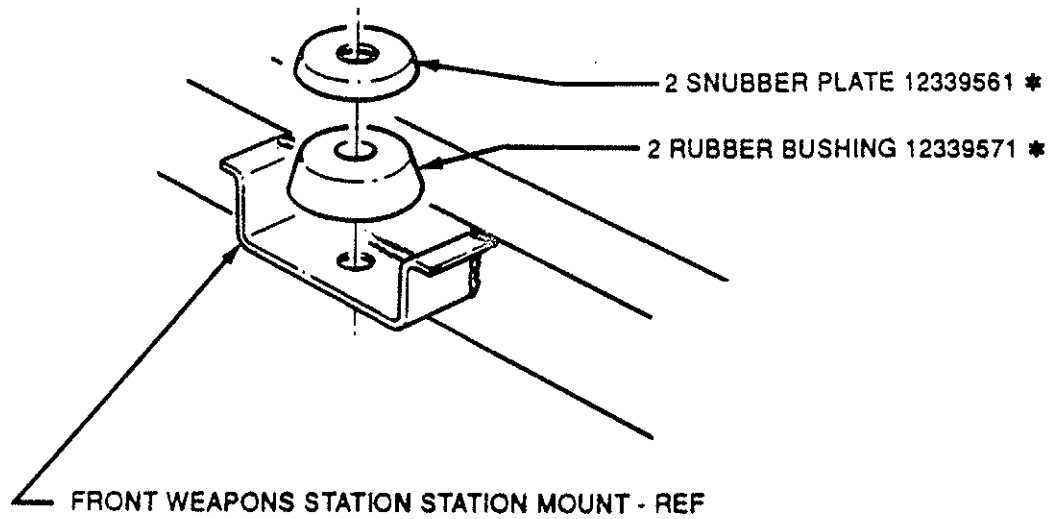

RIGHT SIDE SHOWN,
LEFT SIDE OPPOSITE

Figure 10

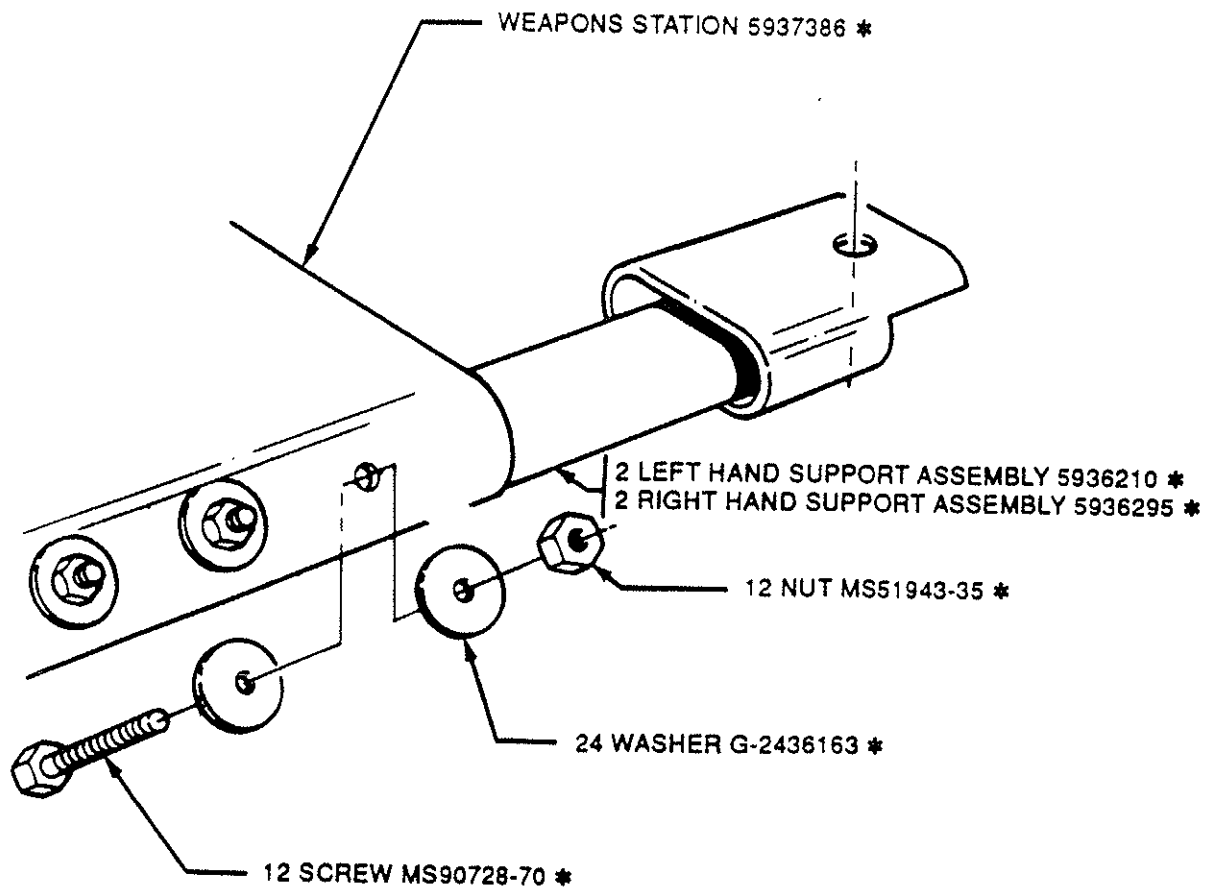

Figure 11

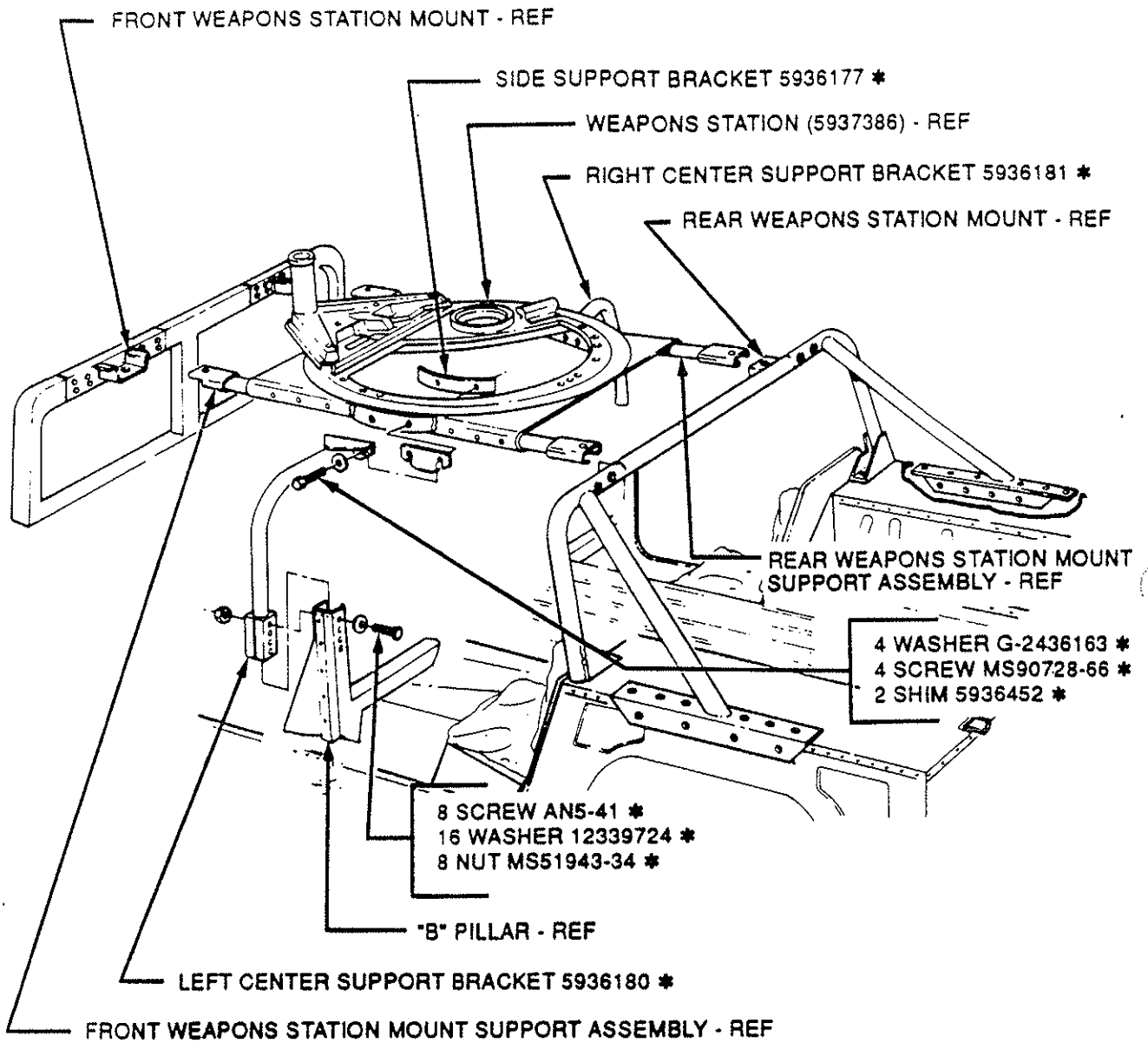

Figure 12

NOTE: SIX SHIMS ARE PROVIDED WITH KIT, SHIM AS REQUIRED TO FILL GAP BETWEEN WEAPONS STATION AND CENTER SUPPORT BRACKETS.

