



CONTROL  
SOLUTIONS™

# TURRET SYSTEMS AND ACCESSORIES CATALOG

2016



Control Solutions has been providing military systems for over 20 years. We are one of the first companies to provide heavy turret motor controllers for the armored HMMWVs and MRAPs. Our Turret Control System (TCS) has been fielded on over 70,000 platforms.

The Warfighter relies on our products to reduce gunner fatigue and improve their safety, while keeping their eyes on the mission and hands on the weapon.

Control Solutions LLC is your one-stop solution provider for tough motion control problems. Our team of engineers and ISO-certified manufacturing personnel stand ready to quickly solve, design, and manufacture your custom solution today.

BR0097-05



Visit our website:  
[www.controls.com](http://www.controls.com)

CONTROL SOLUTIONS LLC™  
2520 Diehl Road, Aurora, Illinois 60502  
Tel: 630.806.7062 Fax: 630.806.7065

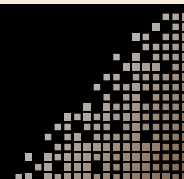

# TABLE OF CONTENTS



**Remote Suppressive Fire\* System (RSF) ..... Page 1**



\* Patent Pending



**CS5000 Series Light-Weight Turret Systems ..... Page 2**

CS5000 Series Turret Assemblies ..... Page 4

Motorized and Hand-Crank turrets ..... Page 5

CS5000 Series Applications ..... Page 7



CS6400



CS7100

**CS6400 HDT Heavy Duty Turret ..... Page 8**

CS6400 Turret Applications ..... Page 10

**CS7100 Turret Drive System ..... Page 11**



**Weapon-Mounted Turret Controllers and Accessories ..... Page 12**

All specifications subject to change without notification.





# Remote Suppressive Fire™ (RSF) System

## Remote Operation of Turrets for Tactical Vehicles

Patent Pending

### Features/Benefits

- Enables the existing turret to be remotely operated from inside the vehicle
- Gunner can be protected inside the vehicle cabin and not exposed to overhead/blast threats
- Provides stabilized suppressive fire via joystick trigger
- Target can be viewed via the video display
- Improves crew safety and survivability
- Cost effective and seamless upgrade to already fielded turrets/gunner protection kits

### Description

The **Remote Suppressive Fire™ (RSF)** system allows the crew to remotely operate the gunner station while protected inside of the armored vehicle. The RSF is a simple add-on to existing manned turrets currently in use on up-armored HMMWV's and MRAPS. It provides critical "shoot-on-the move" suppressive fire capability and enables the gunner to be protected from high-threat scenarios such as sniper fire, artillery/mortar attacks, and IED environments.

When the gunner senses the need for better protection, he can move down inside the vehicle and switch to remote engagement mode by pressing a button on the control box. This locks the gun in alignment with the camera and activates the firing solenoid, camera, display, weapon stabilization, elevation drive, and joystick. The gunner then uses the joystick and trigger button to acquire and engage the target with suppressive fire.

The RSF is not a replacement for CROWS. Instead, the RSF fills a major capability gap between the GPK and CROWS by providing a suppressive fire capability in dangerous situations. Unlike CROWS, **RSF does not require an expensive ballistic computer, laser ranging** or CROWS-like precision. The RSF provides the gunner with the same functionality as a traditional manned turret but from inside the protected confines of the armored vehicle.

The RSF consists of commercial-off-the-shelf components. These "plug-and-play" components include a remote fire solenoid, gun elevation drive, day/night camera with infrared illuminator, simplified weapon stabilization, a display, and a joystick with trigger. All of these components are easily integrated into existing turrets. The RSF weapon system is simple to operate with minimal training.

The RSF system provides a major tactical advantage by allowing the gunner to deliver suppressive firepower in critical situations.



Traditional turret operation



RSF enables remote operation of the turret while protected inside the vehicle

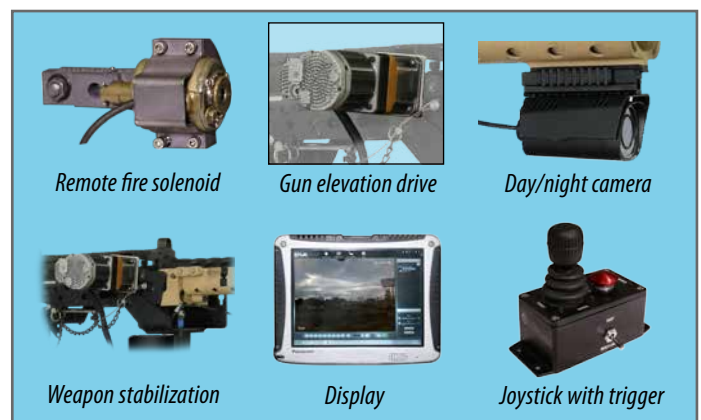

RSF System Components

### About Us

Control Solutions LLC has designed and manufactured field-hardened systems to meet the challenges of the military for over 20 years. Control Solutions LLC, your rapid-response provider of motion control solutions.



## Lightweight Gun Turret

### Features/Benefits

- Lightest powered turret on the market (165 lbs.)
- Motorized, hand-cranked and manual models available
- Common ring-mount solution for various vehicles
- Fixed or Flexible A-Frame Available
- Flexible A-Frame provides gun tilt range from -15 to + 30 degrees
- Easy vehicle integration and installation
- Supports multiple weapon systems
- Optional gun shield and gunner protection kits in steel, ceramic or composite armor



Shown full featured CS5200 Lightweight Motorized Gun Turret.

### Description

The **CS5000 Series Turrets are the lightest turrets on the market today.** The Lightweight Gun Turret (LGT) provides a one-piece system that can be easily mounted on almost any vehicle. The base turret weight is only 165 lbs (75kg) making it an ideal choice for tactical vehicles. Reducing the vehicle weight will continue to be a key requirement of military and police forces worldwide.

We have many configurations to choose from to fit your budget and needs. We have our base, hand-cranked version to a fully motorized turret with weapon mounted turret controllers, which allows the gunner to operate via a finger-tip or thumb controller without taking their eyes off the target.

The CS5000 table below shows the base unit and common specifications. This is a good starting point when trying to spec a turret for your vehicle.

#### CS5000 Series Common Specifications

Overall weight, pounds (metric)	165 lbs (75kg) [without weapon or pintle mount]
Turret Ring Diameter, Inches (mm)	ID: 30.2 (768) – OD: 38.8 (978)
Vehicle rooftop mounting hole, Inches (mm)	36 (915) nominal using M10 bolts
Armament	Qualified with 7.62mm – 12.7mm – 40mm AGL, buffered mount recommended
Safe zone	No-fire zone can be installed preventing traverse of the LGT in this area
Protection for gunner	Can be modified to provide ballistic protection up to STANAG 4569 level 3
Overhead protection	Adjustable ballistic top cover protection can be installed

All specifications subject to change without notification.



Visit our website:  
[www.controls.com](http://www.controls.com)



## Lightweight Gun Turret

### Specifications

Common for all models	
Voltage	24 VDC
Current	12A (nominal) – 40A (stall)
Overall weight, pounds (metric)	165 lbs (75kg) [without weapon or pintle mount]
Turret Ring Diameter, Inches (mm)	ID: 30.2 (768) – OD: 38.8 (978)
Vehicle rooftop mounting hole, Inches (mm)	36 (915) nominal using M10 bolts
Armament	Qualified with 7.62mm – 12.7mm – 40mm AGL, buffered mount recommended
Adjustable gun mount A-frame	-15° to + 30°
Manual operation	Yes (if vehicle power fails)
Safe zone	No-fire zone can be installed preventing traverse of the LMGT in this area
Protection for gunner	Can be modified to provide ballistic protection up to STANAG 4569 level 3
Overhead protection	Adjustable ballistic top cover protection can be installed

Model	Base	Power Train	Flex A-Frame	Fixed A-Frame	Hatch Cover	Hand Crank
CS5200	■	■	■	-	■	-
CS5210	■	■	■	-	-	-
CS5230	■	■	-	■	■	-
CS5240	■	■	-	■	-	-
CS5300	■	-	-	■	■	■
CS5310	■	-	■	-	-	■
CS5330	■	-	-	■	■	■
CS5340	■	-	-	■	-	■
CS5350	■	-	-	■	-	-

■ = assemblies included.

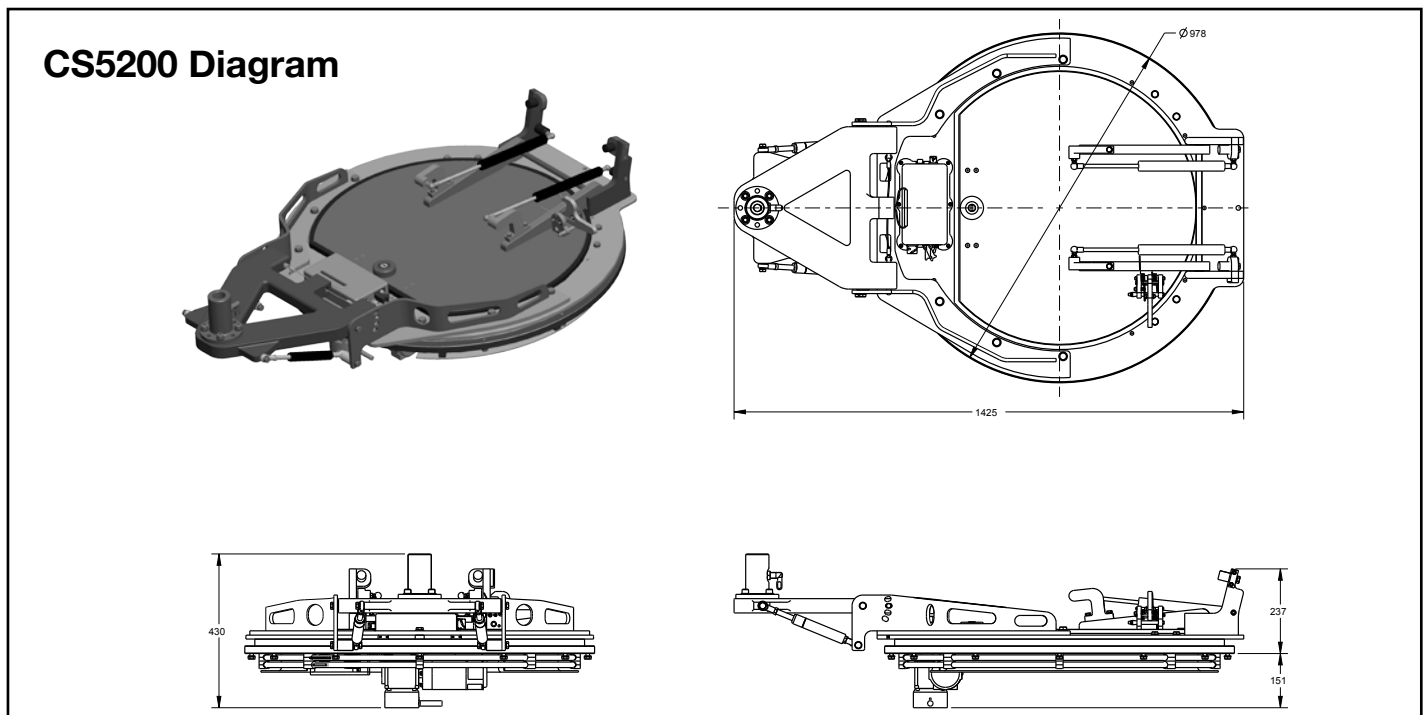

Note: Specifications are subject to change without notice.

## Turret Assemblies

Assemblies	Description
	<p><b>Flex A-Frame</b> Flexible frame provides gun tilt range from -15 to + 30 degrees. The Flexible A-frame is ideal for urban or mountainous operational environments where engagement of the enemy from an elevated position is a concern. The Flexible A-Frame allows for easy/quick weapon height adjustment for gunners of varying height profiles.</p> <ul style="list-style-type: none"> <li>• Supports multiple weapon systems</li> <li>• Light weight aluminum construction</li> </ul>
	<p><b>Fixed A-Frame</b> Rigid sturdy frame</p> <ul style="list-style-type: none"> <li>• Supports multiple weapon systems</li> <li>• Light weight aluminum construction</li> </ul>
	<p><b>Hatch Cover</b> Light weight hatch cover weighs only 35lbs.</p> <ul style="list-style-type: none"> <li>• Light weight aluminum construction</li> <li>• Can be modified to provide ballistic protection up to STANAG 4569 level 3</li> </ul>
	<p><b>Base</b> Common on all CS5000 Series Light-Weight turrets.</p> <ul style="list-style-type: none"> <li>• Smooth bearing operation.</li> <li>• Light weight aluminum construction</li> </ul>
	<p><b>Power Train</b> For all Motorized LWT</p> <ul style="list-style-type: none"> <li>• Built-in rotary slip ring that connects to vehicles power source, eliminates the need for turret batteries</li> <li>• Rotate 360° in less than 7 seconds</li> <li>• One finger operation using Control Solutions Weapon Mounted Gun Turret controllers</li> <li>• Light weight aluminum construction</li> </ul>
	<p><b>Hand Crank</b> Manual hand crank for the CS5300 Series turrets.</p> <ul style="list-style-type: none"> <li>• No power needed.</li> <li>• Light weight aluminum construction</li> </ul>

# CS5000 Series Turrets

## CS5200 Series Lightweight Motorized Gun Turrets



### CS5200 includes the following:

- Base Turret
- Flex A-Frame
- Hatch
- Power Train
- Flexible A-Frame provides gun tilt range from -15 to + 30 degrees.
- Built-in rotary slip ring that connects to vehicles power source, eliminates the need for turret batteries
- One finger motorized operation using optional accessories CS3210A or CS3320 Weapon Mounted Turret controllers (WMTC)



### CS5210 includes the following:

- Base Turret
- Flex A-Frame
- Power Train
- Flexible A-Frame provides gun tilt range from -15 to + 30 degrees.
- Built-in rotary slip ring that connects to vehicles power source, eliminates the need for turret batteries.
- One finger motorized operation using optional accessories CS3210A or CS3320 Weapon Mounted Turret controllers (WMTC)



### CS5230 includes the following:

- Base Turret
- Fixed A-Frame
- Hatch
- Power Train
- Built-in rotary slip ring that connects to vehicles power source, eliminates the need for turret batteries.
- One finger motorized operation using optional accessories CS3210A or CS3320 Weapon Mounted Turret controllers (WMTC)



### CS5240 includes the following:

- Base Turret
- Fixed A-Frame
- Power Train
- Built-in rotary slip ring that connects to vehicles power source, eliminates the need for turret batteries.
- One finger motorized operation using optional accessories CS3210A or CS3320 Weapon Mounted Turret controllers (WMTC)

## CS5300 Series Lightweight Hand-Crank Gun Turret



### CS5300 includes the following:

- Base Turret
- Flex A-Frame
- Hatch
- Hand-Crank
- Flexible A-Frame provides gun tilt range from -15 to + 30 degrees.



### CS5310 includes the following:

- Base Turret
- Flex A-Frame
- Hand-Crank
- Flexible A-Frame provides gun tilt range from -15 to + 30 degrees.

# CS5000 Series Turrets

## CS5300 Series Lightweight Hand-Crank & Manual Gun Turret



### CS5330 includes the following:

- Base Turret
- Fixed A-Frame
- Hatch
- Hand-Crank



### CS5340 includes the following:

- Base Turret
- Fixed A-Frame
- Hand-Crank



### CS5350 includes the following:

- Entry level manual turret.
- Base Turret
  - Fixed A-Frame
  - Base Manual Locking Handle

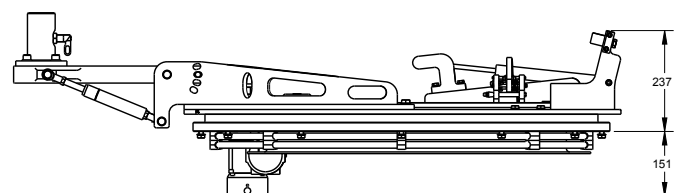
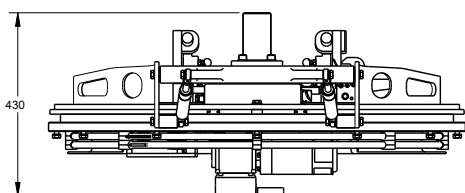
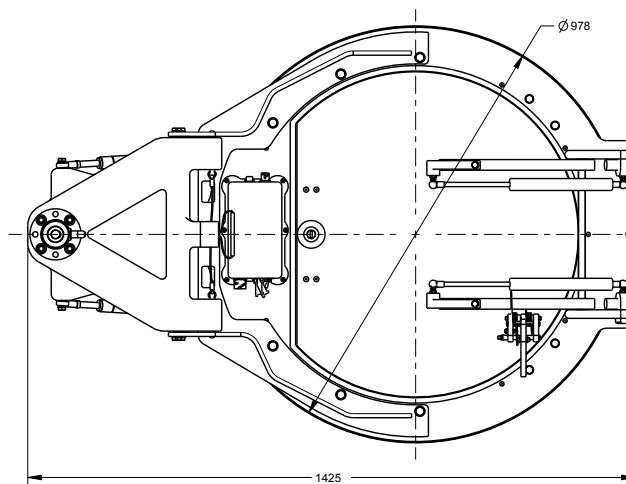



## Applications

### Lightweight Turret Applications

The CS5000 Series of lightweight turrets are ideal for many uses including but not limited to, military police, SWAT, border guard posts and other vehicle applications where weight and center of gravity issues are of primary concern



### Custom and Non-lethal Solutions

We can design and configure our turrets for non-lethal applications as well.



## Heavy Duty Turret (HDT)

### Features/Benefits

- Supports payloads up to 2200 lbs.
- One finger motorized operation on the move
- Ideal for APC's with ballistic steel gunner protection kits.
- Common ring-mount solution for various vehicles
- Easy vehicle integration and installation
- Supports multiple weapon systems
- Self contained power slip ring allows turret to be powered from vehicle, eliminates the need for external batteries.
- Manual Override

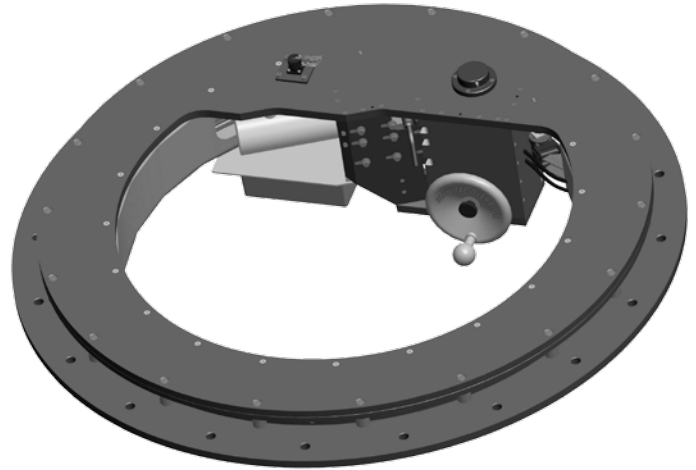

### Description

When your tactical wheeled vehicles need a larger turret capable of supporting heavier weapon systems, the Heavy Duty Turret (HDT) by Control Solutions meets those specifications.

With our line of turret accessories, slip rings, hatches, gun mounts, weapon-mounted controllers, spotlights, auxiliary power modules, gunner protection kits and more, the HDT system has the flexibility you can spec for your tactical vehicle.



### About Us

Designing and manufacturing field-hardened systems to meet the challenges of the military for over 20 years. Control Solutions LLC, your rapid-response provider of motion control solutions.



Smoothly rotate the HDT via CS3210A weapon-mounted turret controller.

## Heavy Duty Turret (HDT)

### Specifications

<b>Heavy Duty Turret</b>	
Maximum Supported Weight	2200 lbs.
Voltage	24 VDC
Overall weight, pounds (metric)	490 lbs (222) [ without weapon or pintle mount ]
Turret Ring Diameter, Inches (mm)	ID: 30.7 (780) – OD: 45.25 (1150)
Vehicle interface mount plate inches (mm)	Overall OD: 45.25" (1148 mm), Vehicle Mount BC. Dia.: 42.25" Dia. (1073 mm) Qty. 20 clearance holes: .65" (16.51 mm). Required ID clearance: 37.25" (946 mm)
Gun Mount interface plate	Overall OD: 41.25" (1048 mm), B.C. Interface 40.13" (1019 mm) Qty. 18 0.50"-13UNC. Internal gunner clearance 30.7" (780 mm) Dia. minus gear drive train provisions.
Height above vehicle mount interface (fay surface)	Top plate surface: 3.3" (84 mm), Top Plate Bearing Cap 4.7" (119).
Depth below vehicle mount interface (fay surface)	Slip ring guard: 2.1" (53 mm), Bottom of drive unit: 6" (152 mm), Note: Distance manual drive wheel extends below bottom of drive unit depends on wheel diameter selected.
Armament	Can be manufactured to: NATO or Non-NATO specifications
Manual operation	Yes (if vehicle power fails)
Protection for gunner	GPK can be provided per customers specifications
Overhead protection	Ballistic hatch cover can be provided per customer specification.

### CS6400 Series Diagram

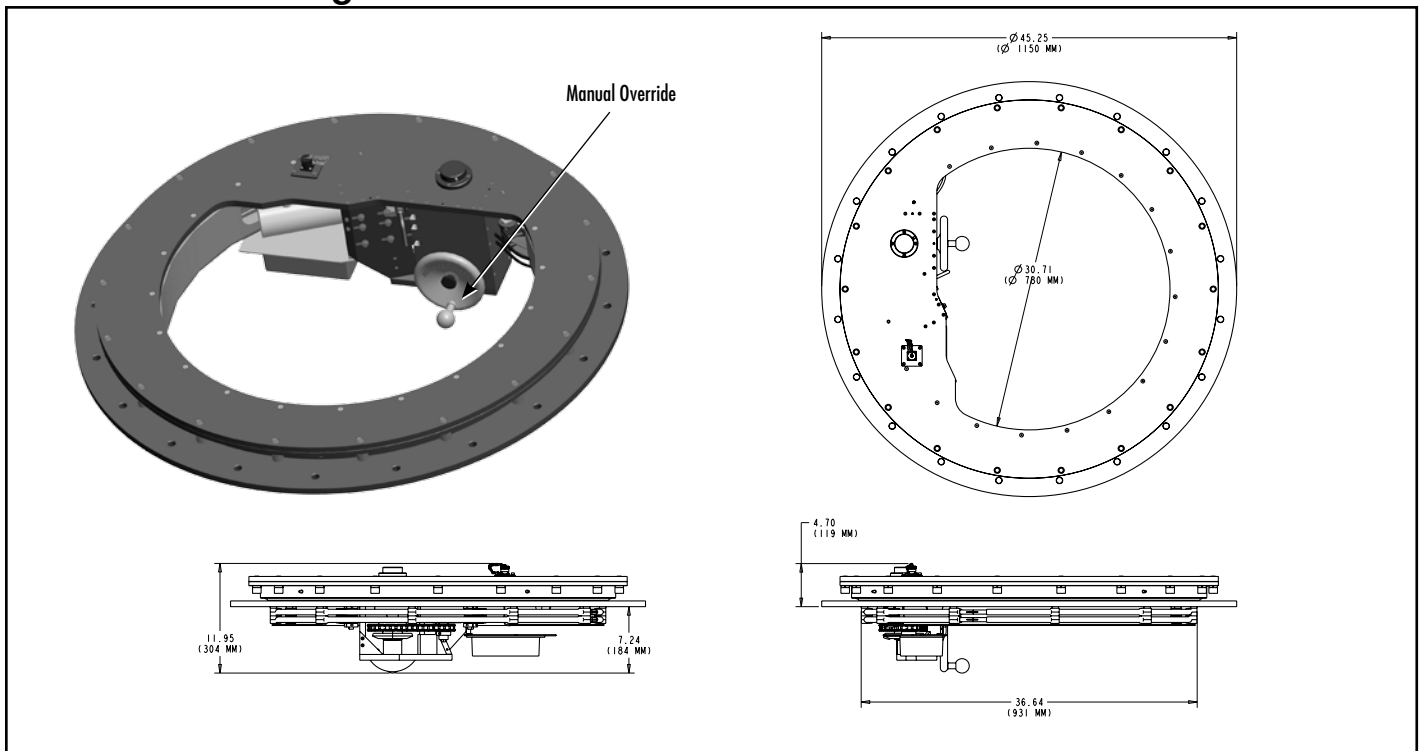

Note: Specifications are subject to change without notice.



## Turret Applications

### Heavy Duty Turret Applications

The CS6400 HDT turret is ideal for the larger MRAPS and Armored Personnel Carriers that can support payloads up to 2200 lbs.





## Turret Drive System

### Features/Benefits

- Turret Drive System for tactical vehicles
- Provides power to move turrets with payloads up to 2000 lb /910 kg (dependent upon gunner protection kit (GPK)/weapon geometry).
- Easy to use engagement/disengagement handle
- Manual Override
- Ideal for driving manual turrets with heavy GPKs/ cupolas
- Cost effective and efficient solution for automating existing manual turrets

### Description

The **CS7100 Turret Drive System (TDS)** provides smooth, proportional acceleration and control of tactical vehicle turrets. This fully integrated proprietary system combines a rugged military-grade variable speed motor and battle-tested DC motor controller into one easy to install assembly. Operation of the turret is via our CS3209 Joystick, CS3210A Thumb Drive or the CS3310 Fingertip Drive Actuators.

**The Problem:** Tremendous physical effort is required for the gunner to manually rotate turrets with heavy GPKs and cupolas. Manually operated turrets also require the gunner to disengage the target while slewing the weapon.

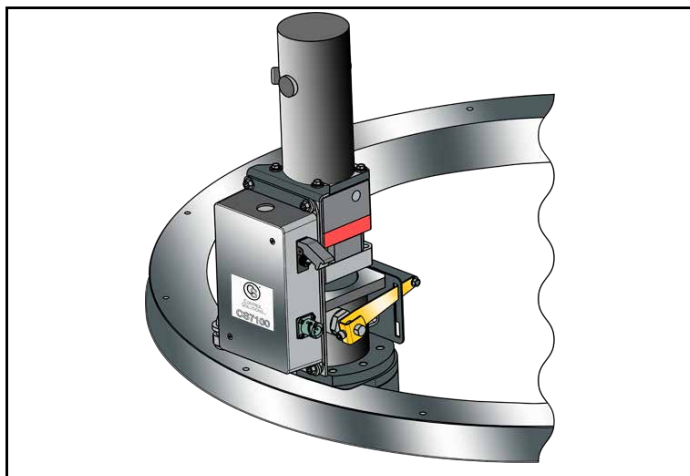

Also available in horizontal configuration.



CS7100 Turret Drive System

**The Solution:** The CS7100 TDS enables the following:

1. Quicker target acquisition = Increased lethality
2. With the CS3210A or CS3310, the gunner never has to remove hands from weapon to traverse turret and can maintain a constant sight picture during engagements.
3. Better control over weapon positioning than non-powered solutions
4. Less gunner fatigue. The turret can be easily operated under high slope/gradient conditions.

### About Us

Control Solutions LLC has designed and manufactured field-hardened systems to meet the challenges of the military for over 20 years. Control Solutions LLC, your rapid-response provider of motion control solutions.

CS7100 Turret Drive System Specifications	
Size (HxWxL) Inches (mm)	16.5 x 7.58 x 7.10 (419 x 193 x 180)
Weight, pounds (metric)	35 lb (16kg)
Operating voltage	24V
Operating current	<10A
Maximum supported payload weight, pounds (metric)	2000 lb, (910 kg)
Rotations per minute	6-8 based on configurations of turret.
Manual operation	Yes (if vehicle power fails)

All specifications subject to change without notification.

# Weapon-Mounted Turret Controllers and Accessories

## Accessories



**CS3210A**

### CS3210A Weapon Mounted Turret Controller

- Maintain positive control through simultaneous turret and weapon control
- Smooth two-direction turret slew control
- Left-side or right-side mounting configurations on the M2 or MK19)
- Directly cabled to BPMTU/ITDS controller via Mil-C-5015
- No tools needed to mount WMC



**CS3310, CS3320,  
CS3330**

### CS3300 Series Weapon Mounted Turret Controllers

- Durable hook & loop fastening system allows for secure mounting to different weapon stock shapes
- Directly cabled to BPMTU/ITDS controller
- CS3310 mounts to the right-hand side of the stock of the M240B weapon.
- CS3320 mounts to the right-hand side of the stock of the M249 weapon
- CS3330 mounts to the right-hand side of the M249 collapsible buttstock.



**CS3209B**

### CS3209B Joystick

- Waterproof and dustproof
- Gasket-sealed aluminum enclosure with magnetic base
- EMI hardened
- Designed and manufactured in the U.S.A.
- Designed to comply with U.S. and European safety standards and regulations
- Single axis, non contact hall-effect technology for long life
- Used in conjunction with CSLLC's CS3248 improved Turret Drive System motor controller, CS3208 BPMTU controller and all CS5200 Series Turrets



**CS2152**

### CS2152 TCS Auxiliary Power Module

- Provides in-turret power for gunner accessories
- Includes 12V and 24V protected circuits for gunner station accessories
- Includes 5V USB power outlet
- Power is independent of vehicle battery
- Sealed Connections allow for all-weather day and night operation
- Compatible with weapons mounted controller



**CS3460**

### CS3460 Gun Turret Spotlight

- High-intensity white LED light and night-vision in same unit
- Powerful LED white light visible for over 150 meters
- Wide-angle IR light for use with night vision devices
- Single-switch operation from Turret Auxiliary Module
- Mounts easily onto either side of the O-GPK



**CS5400**

### CS5400 Large-diameter Turret Slip Ring

- Allows turret to be powered from vehicle batteries; eliminates turret batteries and reduces weight
- Multiple data and video channels; simultaneous uplink & downlink
- Floating design; isolated from vehicle vibrations
- Environmentally sealed; retrofittable



Founded in 1989, Control Solutions designed the first microprocessor-based DC motor controller used in the scooter industry. Since then, Control Solutions has grown to become the industry leader in motion-control solutions.

Today, that technology is used in our military products such as our Turret Control System (TCS) and Powered Door Systems (PDS). We have over 70,000 turret motion control systems fielded to the U.S. Government.



- Located in Aurora, IL USA
- 75 employees, 20 engineers
- Integrated design & manufacturing facility: 130,000 sq. ft.
- Products are "Made in USA" using an international supply chain
- Rapid growth has resulted from selection of CSLLC's motion control technology for commercial and military markets
- Urgent operational requirements in Iraq and Afghanistan created a need for rugged, safety and survivability systems for tactical wheeled vehicles
- Rapid design, prototyping and delivery to meet extreme performance and environmental demands
- Fielded over 70,000 turret motion control systems to the U.S. Government



Control Solutions corporate headquarters and manufacturing  
Aurora, Illinois





## Contact:

**David Rodgers**  
Director, Government Business Development  
Direct: 630-715-8705  
Email: drodgers@controls.com

**Bruce Florack**  
Business Development Manager  
Direct: 630-806-9795  
Email: bflorack@controls.com

**Robert B. Stratton**  
Business Development Executive  
Direct: 763-323-8597  
Email: rstratton@controls.com



Control Solutions LLC • 2520 Diehl Road • Aurora, IL 60502  
Tel: 630-806-7062 • Fax: 630-806-7065 • Email: info@controls.com



Visit our website:  
[www.controls.com](http://www.controls.com)

